

Stellar® Service Cranes and TMAX™ Service Bodies

12621 / 12630



TECHNICAL SPECIFICATION GUIDE



Our People. Our Products.

STELLAR® I2621/I2630 TECHNICAL SPECIFICATION GUIDE

SPECIFICATION INFORMATION

Crane Rating:	77,800 ft-lbs (10.76 tm)
12621 Boom Length:	11' (3.35 m) from CL of Crane
12630 Boom Length:	13' 4" (4.06 m) from CL of Crane
12621 Boom Extension:	
• 1st Stage:	Hydraulic 60" (152.4 cm)
• 2nd Stage:	Hydraulic 60" (152.4 cm)
12630 Boom Extension:	
• 1st Stage:	Hydraulic 100" (254 cm)
• 2nd Stage:	Hydraulic 100" (254 cm)
12621 Max. Reach:	21' (6.40 m) from CL of Crane
12630 Max. Reach:	30' (9.14 m) from CL of Crane
12621 Max. Vertical Lift:	23' (7.01 m)
12630 Max. Vertical Lift:	31' 9" (9.68 m)
Boom Elevation:	-10° to +80°
Stowed Height: (crane only)	35" (88.9 cm)
Mounting Space Required:	20" x 21" (50.8 x 53.3 cm)
Approximate Crane Weight:	12621 - 2,235 lbs (1,015 kg) 12630 - 2,580 lbs (1,170 kg)
Controls:	Stellar® CDTplus™ radio control standard for all functions
Winch	
• Rope Diameter:	7/16" (1.11 cm) 6X19 IWRC-DGXXIP X 100' (30.48 m)
• Line pull speed:	55 ft/min (16.76 m)
• Max. single part line:	6,000 lbs (2,721 kg)
• Max. double part line:	12,000 lbs (5,443 kg)
Rotation:	400° power (worm gear)
12621 Lifting Capacities:	12,000 lbs @ 5.5' (5,443 kg @ 1.68 m)** 3,705 lbs @ 21' (1680 kg @ 6.40 m)**
12630 Lifting Capacities:	12,000 lbs @ 5.5' (5,443 kg @ 1.68 m)** 2,590 lbs @ 30' (1245 kg @ 8.69 m)**
Power Supply Required:	PTO & Pump 8 gpm @ 3000 psi (30.3 lpm @ 207 bars)
Min. Rec. Chassis (GVRW)	25,999

NOTE: All Stellar cranes meet ANSI B30.5 and OSHA 1910.180 specifications. Specifications subject to change without notification.

*Crane rating in Boost Mode. Normal crane rating is 66,000 ft-lbs (9.13 ton-m)

**Maximum capacities in Boost Mode.

DEFINING CHARACTERISTICS

Stellar® CDTplus™ (Crane Dynamics Technology Plus™)

The Stellar CDTplus control system is EXCLUSIVE TO STELLAR and features a NEW handheld transmitter with an over-molded rubber bumper system to maximize durability while keeping it lightweight. The new LCD display features operator feedback including real time load capacity, maximum distance with the current load, boom angle, and percentage of load. The boost feature allows a momentary increase in the capacity of the crane, and a Safe Mode to keep the crane and operator safe should a load indicating device fail to operate correctly. The new Stellar CDTplus remote handle features a rechargeable battery and an in-cab docking and recharging station.

Full Hydraulic Extension

The Stellar CDTplus series offers cranes in either 21' or 30' of all hydraulic reach. No manual extensions.

Market Leading Boom Articulation

The Stellar CDTplus cranes offer -10 degrees to +80 degree. This gives the operator both easy reach to snatch block stowing and the best ability to load items into the load bed.

Quick Release Snatch Block Stow

The Stellar quick release snatch block stow is installed on the underside of the boom to easily stow your snatch block after use. Plus, its unique design gently releases the snatch block for use when the boom is raised at close to 60 degrees to ensure a safe and orderly deployment.

On-Demand Speed Control

The Stellar exclusive on-demand speed control ramps engine RPM up only when the crane is being used. When the crane is not used for 5 seconds engine RPM returns to idle. This lowers fuel consumption and reduces noise pollution in the work area.

Maximum Foot-Pound Rating

The Stellar CDTplus series cranes offers robust ft. lb. ratings during standard mode and increases that by 18% during "Boost" mode to help you get maximum lift when you need it most.

Planetary Winch

The planetary winch on every crane manufactured by Stellar was designed to match the capacity and hydraulic control system. It lifts the maximum crane load and offers the smoothest and fastest speeds in the market today to help keep your productivity at maximum levels.

400 Degree Enclosed Rotation

Stellar uses a durable enclosed rotation system with a cast iron base and an internal mechanical stop to provide the most durable rotation system found in the industry.

Greaseable Pivot Bushings

Each pivot pin location on the CDTplus series crane includes bushings and grease zerks to provide for years of use.

Hexagonal Booms

Stellar Industries made the hexagonal boom design famous in the telescopic service crane market. The hexagonal boom design is optimized to deliver dramatically less boom flex and side to side movement than other boom designs on the market.

Flip Sheave with Bar Style Anti-Two Block

The Stellar CDTplus series is available standard with our patent pending flip sheave with a bar style ATB. The flip sheave allows for a shorter horse head profile which allows for boom placement in tight quarters, such as an equipment cab.

12621 CAPACITY CHART

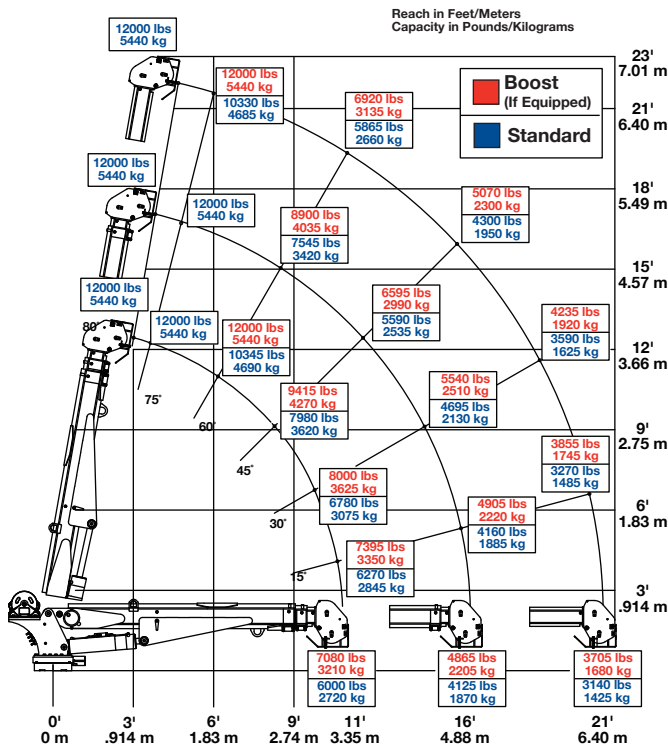

Weight of load handling devices are part of the load lifted and must be deducted from the capacity.

Maximum 1 - part line capacity is 6000 lbs. (2720 kg). For greater loads, use 2 - part line.

12630 CAPACITY CHART

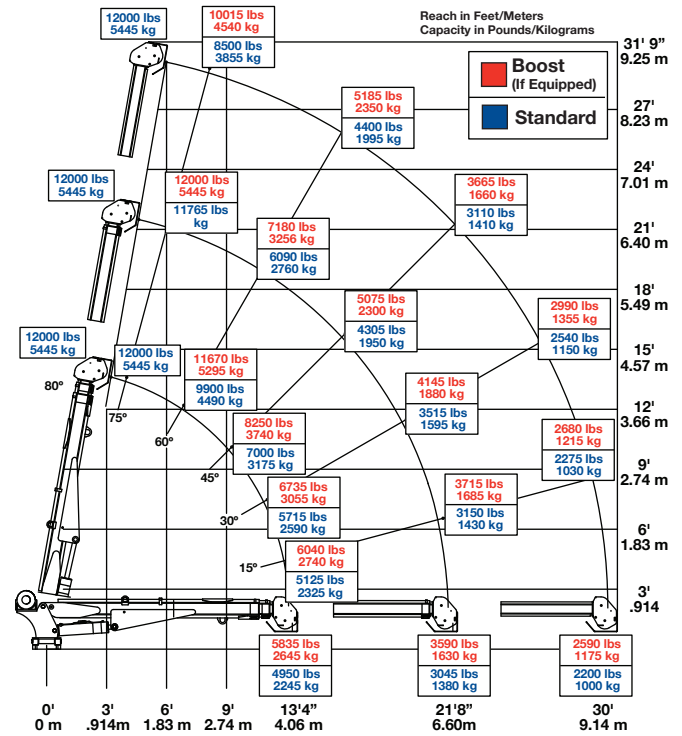

Weight of load handling devices are part of the load lifted and must be deducted from the capacity.

Maximum 1 - part line capacity is 6000 lbs. (2720 kg). For greater loads, use 2 - part line.

12621 DIMENSIONS

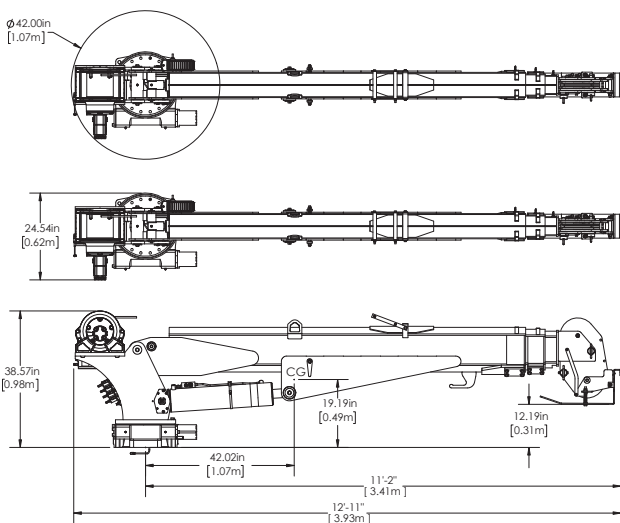

12630 DIMENSIONS

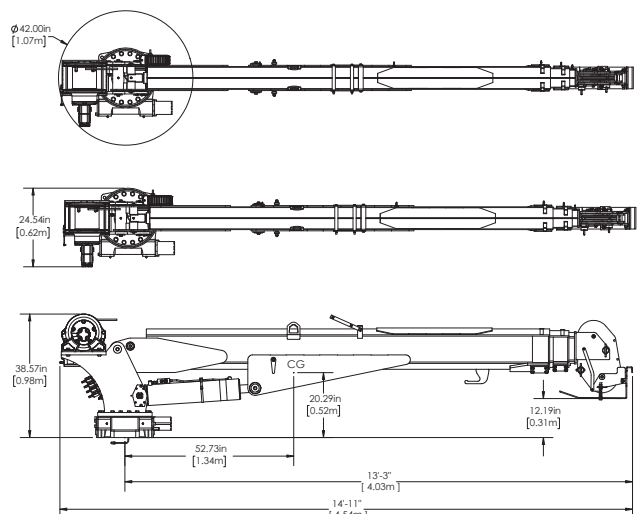

NEW TMAX Service Bodies

TMAX2-11™ Service Body (11' Body)

Applicable Chassis: Above 19,500 GVWR
(22.5 tire size)

Compatible Crane Models: 7621
7630
9621
9630
10621
10630
12621
12630

Cab to Axle: 84" (213.36 cm)
Body Length Nominal: 133" (337.82 cm)
Body Height: 52" (132.08 cm)
Body Width: 94" (238.76 cm)
Compartment Depth: 22" (55.88 cm)
Floor Width: 50" (127 cm)
Net Weight: 3600 lbs (1632.93 kg)

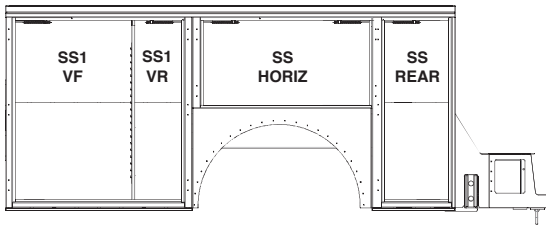
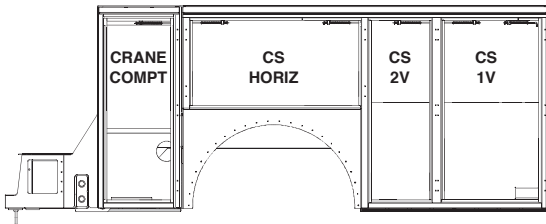

TMAX2-14™ Service Body (14' Body)

Applicable Chassis: Above 19,500 GVWR
(22.5 tire size)

Compatible Crane Models: 7621
7630
9621
9630
10621
10630
12621
12630

Cab to Axle: 120" (304.8 cm)
Body Length Nominal: 157" (398.78 cm)
Body Height: 52" (132.08 cm)
Body Width: 94" (238.76 cm)
Compartment Depth: 22" (55.88 cm)
Floor Width: 50" (127 cm)
Net Weight: 4000 lbs (1814.37 kg)

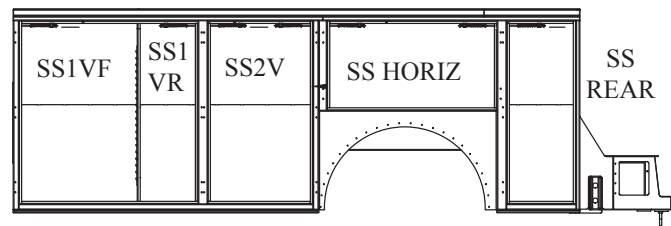
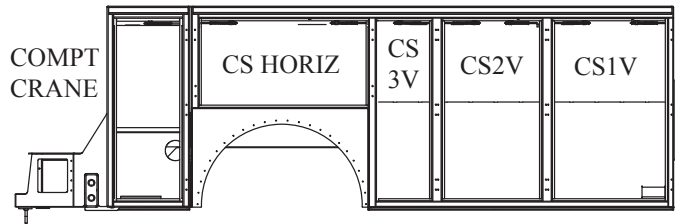

Your local distributor:



Our People. Our Products.

190 State Street
P.O. Box 169
Garner, IA 50438
Telephone: (641) 923-3741 • (800) 321-3741
Fax: (641) 923-2812
Internet: www.stellarindustries.com
Email: sales@stellarindustries.com

An Employee Owned Company.
Copyright © 2016 Stellar Industries, Inc.

STL000063 2/16

Courtesy of CraneMarket