



STELLAR® 6620 TECHNICAL SPECIFICATION GUIDE

6620

Service Crane and T1-11 and T2-11 Service Bodies



Our People. Our Products.

STELLAR® 6620 TECHNICAL SPECIFICATION GUIDE

■ SPECIFICATION INFORMATION

Crane Rating:	38,000 ft-lbs (5.25 ton-m)
Standard Boom Length:	10' 9" (3.28 m) from CL of Crane
Boom Extension:	
• 1st stage:	Hydraulic 60" (152.4 cm)
• 2nd stage:	Hydraulic 60" (152.4 cm)
Max. Horizontal Reach:	20' 9" (6.32 m) from CL of Crane
Max. Vertical Lift: (from crane base)	22' (6.71 m)
Boom Elevation:	-5° to +80°
Stowed Height: (crane only)	32.5" (82.6 cm)
Mounting Space Required:	20" x 21" (50.8 x 53.3 cm)
Shipping Weight:	1625 lbs (735 kg)
Controls:	Radio control standard for all functions
Winch	
• Rope Diameter:	5/16" (.794 cm)
• Line Pull Speed:	60 ft/min (18.29 m)
• Max. Single Part Line:	3000 lbs (1360 kg)
• Max. Double Part Line:	6000 lbs (2720 kg)
Rotation:	400° power (worm gear)
Lifting Capacities:	3525 lbs @ 10'9" (1600 kg @ 3.28 m) 1825 lbs @ 20'9" (830 kg @ 6.32 m)
Power Supply Required:	PTO & Pump 8 gpm @ 2850 psi (30.31 lpm @ 197 bars)

NOTE: All Stellar cranes meet ANSI B30.5 and OSHA 1910.180 specifications. Specifications subject to change without notification.

■ DEFINING CHARACTERISTICS

Remote Control

Stellar Industries was the first U.S. manufacturer to include the state-of-the-art fully proportional multi-functional remote control as a standard feature. The radio remote incorporates a variable speed trigger that allows the operators to feather the crane with precise control. Additionally, the radio remote control handle features engine start/stop functions, compressor on/off, engine speed controls, and an emergency shut-off.

Planetary Drive Winch System

To maximize winch speed, Stellar Industries has incorporated a planetary drive winch system with line speeds up to 60-ft/min (18.29m), giving the 6620 crane over twice the speed of the competition. In addition to speed, the planetary winch also provides mechanical and hydraulic breaks for added security.

Hexagonal Boom Design

Hexagonal booms are stronger and greatly reduce boom flex and side to side movement.

Greaseless Bushings

Maintenance free greaseless bushings.

Stainless Steel Pivot Pins

Lower maintenance and extend life.

20'9" of Hydraulic Reach

2-stage hydraulic extensions. No manual extensions.

Dual Acting Counter Balance Valves

Integrated into cylinders.

Flip Sheave Standard

Anti Two-Block Device

6620 CAPACITY CHART

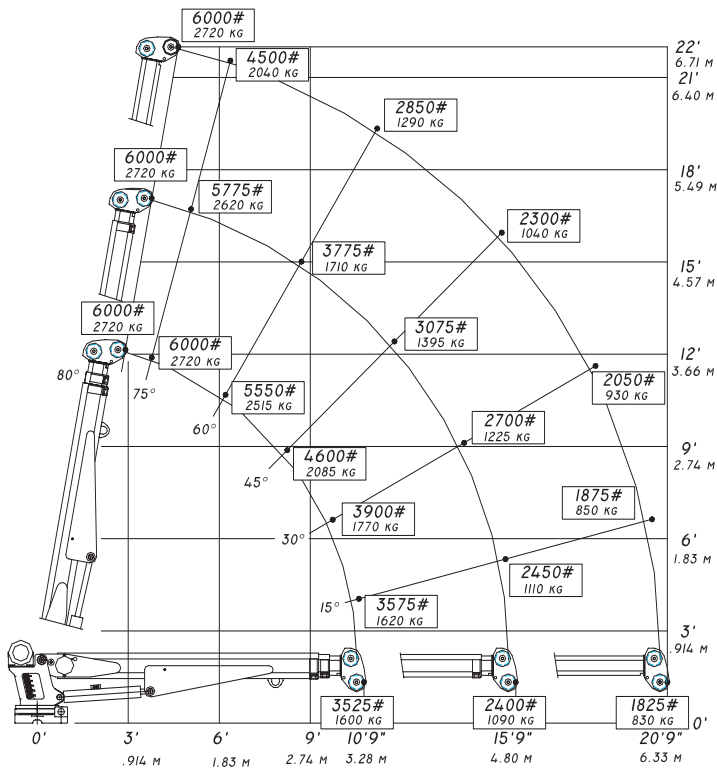

Weight of load handling devices are part of the load lifted and must be deducted from the capacity.

Maximum 1 - part line capacity is 3000 lbs. (1360 kg). For greater loads, use 2 - part line.

GEOMETRIC DIMENSIONS

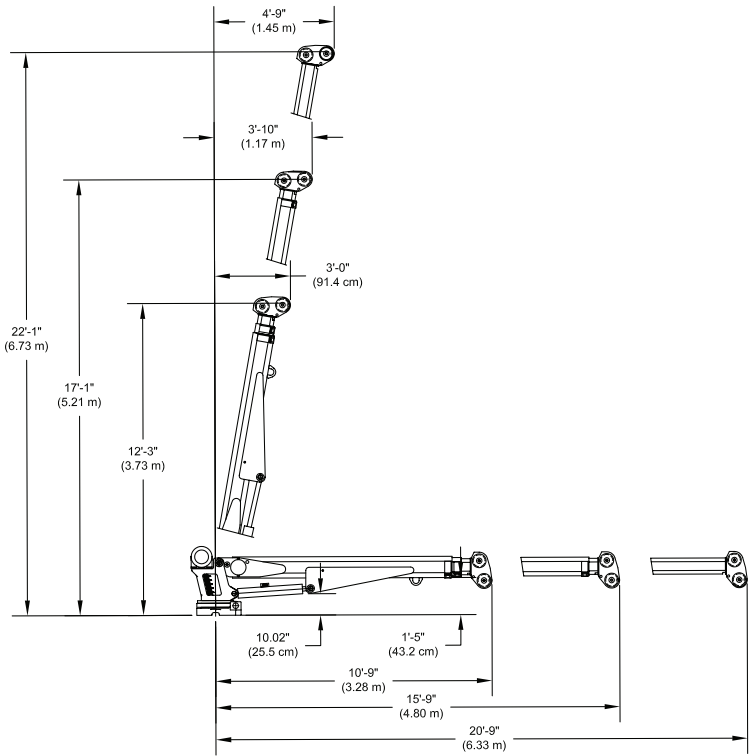

ROTATIONAL CLEARANCE

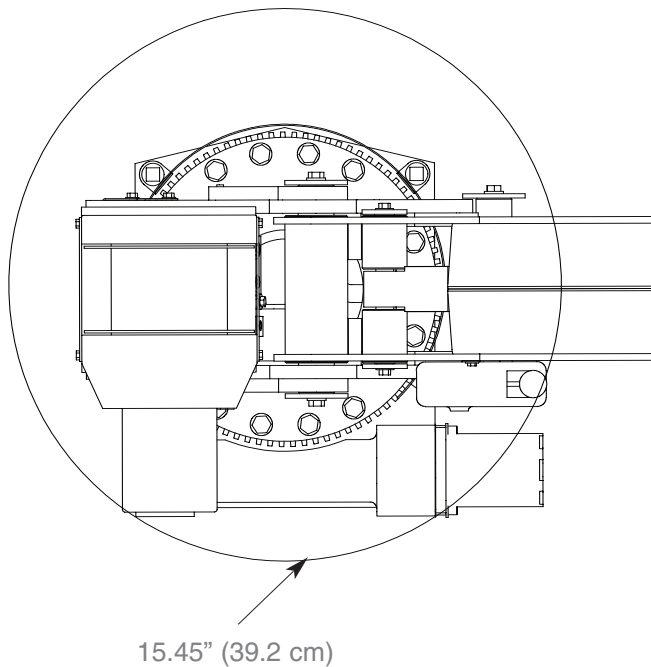

HOLE MOUNTING DETAIL

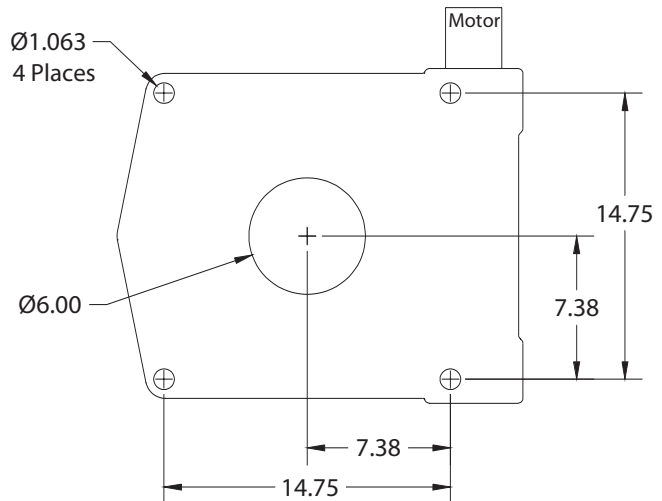

■ Service Bodies

T1-11 Service Body

Applicable Chassis: 16000 GVWR to
19000 GVWR Chassis

Crane Models: 3315
4420
5520
6620
6628

Cab to Axle: 84" (213.36 cm)
Body Length Nominal: 133" (337.82 cm)
Body Height: 44" (111.76 cm)
Body Width: 94" (238.76 cm)
Compartment Depth: 22" (55.88 cm)
Floor Width: 50" (127 cm)
Net Weight: 3220 lbs (1460.37 kg)

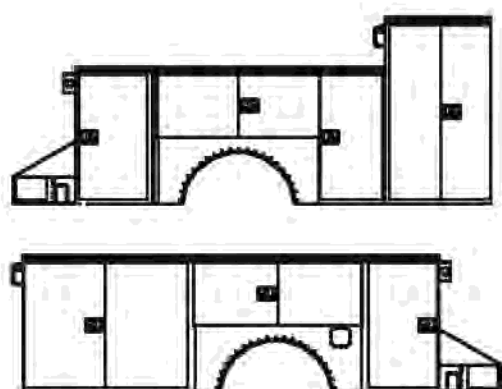

T2-11 Service Body

Applicable Chassis: 19000 GVWR Chassis
and up

Crane Models: 6620
6628
9620
10620
10628

Cab to Axle: 84" (213.36 cm)
Body Length Nominal: 133" (337.82 cm)
Body Height: 52" (132.08 cm)
Body Width: 94" (238.76 cm)
Compartment Depth: 22" (55.88 cm)
Floor Width: 50" (127 cm)
Net Weight: 3600 lbs (1632.93 kg)

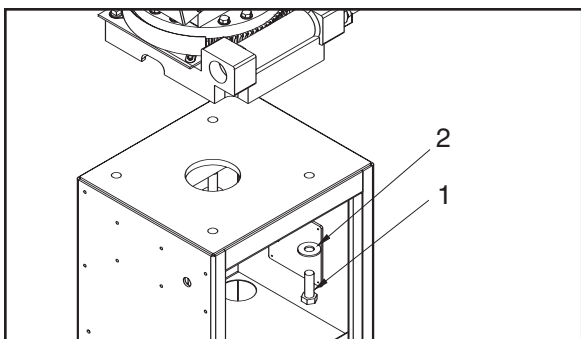
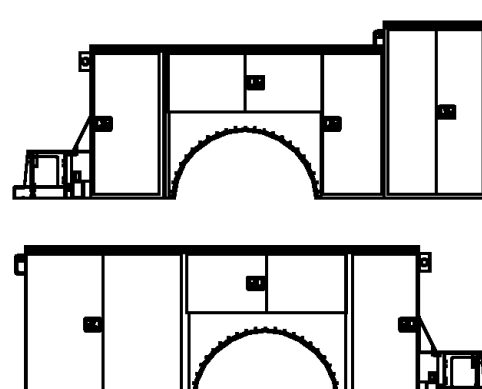

Item	Part	Description	Qty.
1	5199	Cap Scr 1.00-8x3.00 HHGR8 ZY	4
2	1443	Washer 1.00 Flat Zinc	4

Your local dealer:



Our People. Our Products.

190 State Street
P.O. Box 169
Garner, IA 50438
Telephone: (641) 923-3741 • (800) 321-3741
Fax: (641) 923-2812
Internet: www.stellarindustries.com
Email: sales@stellarindustries.com

An Employee Owned Company.
Copyright © 2008 Stellar Industries, Inc.

4/08

Courtesy of CraneMarket