



TELESCOPIC BOOM CRAWLER CRANE

MANTIS[®]
CRANES

200RS

GENERAL DATA

CRANE CAPACITY	200,000 lbs at 8 ft (90.4t @ 2.4m)
BOOM	3-section, 26ft – 54ft (7.9m – 16.4m)
DIMENSION	
Overall Length	36'-4" (11.08m)
Overall Width (tracks extended)	17'-8" (5.38m)
Overall Width (tracks retracted)	12'-0" (3.66m)
Overall Width (tracks removed)	10'-10 1/2" (3.32m)
Overall Height (handrails folded down)	12'-6" (3.81m)
Ground Clearance	2 ft (0.6 m)
MASS	
Gross Vehicle Mass (Standard Equipment Package)	153,000 LBS (69,550 kg)
PERFORMANCE	
Travel Speed	1.1 mph – 3.3 mph (1.8 km/h – 5.3 km/h)
Tractive Effort	140,000 LBS (622 kN)

CRANE SPECIFICATIONS

Maximum Lifting Capacity

100 ton @ 8 ft (90.4t @ 2.4m)

Boom

3-section full power synchronized telescoping boom. Synchronized telescoping system consists of two double acting hydraulic cylinders with load holding valves.

- Retracted Length: 26.1 ft (7.95m)
- Extended Length: 54.1 ft (16.49m)
- Elevating Angles: -1° to 78°
- Hook Block: 100 ton Crosby side boom style hook block and pendant block.

Winches

Planetary geared two-speed winch includes a bent axis hydraulic motor, multi-disc internal brake and counterbalance valve. Drum rotation indicator is included

- Main winch: Braden Model CH400, 2-speed fitted with 800' (244m) of 3/4" (19mm) 6 x 37 class, regular right lay, EIPS, IWRC wire rope.

Travel

Each side frame contains two pilot controlled, two-speed track drive with hydraulic axial piston motor and parking brake. Travel system provides skid steering and counter rotation.

- Low travel speed: 1.1mph (1.8 km/h)
- High travel speed : 3.3 mph (5.3 km/h)
- Tractive Effort: 140,000 lbs (622 kN)

Load Moment Indicator & Anti -Two Block

Standard Rated Capacity Limiter and Anti-Two Block system

- Control function shutdown. Audible and visual warnings
- LCD screen provides a continuous display of working boom length, boom angle, working load radius, tip height, parts-of-line (operator set), machine track configuration, relative load moment, maximum permissible load and actual load.

Specifications are subject to change without prior notice.

Operator's Cab

Fully-enclosed, air conditioned all-steel modular cab with lockable swinging door, acoustical lining, anti-slip floor and tinted safety glass.

- Rear view cameras are appropriately located as are four remote control work lights.
- 2-speed windshield wiper, top glass wiper
- Six-way adjustable fabric seat with headrest, seat belt
- Two-way hydraulic piloted armrest mounted joysticks control swing, boom extend, main winch, and boom hoist. Hydraulic pilot foot pedals control the travel and swing service brake functions.
- Engine Throttle: Foot Throttle or Auto-Idle throttle control
- Seat and armrest termination switches immediately disable all hydraulic functions as the operator rises from the seat or lifts the left hand armrest.

Dash instrumentation: tachometer, voltmeter, temperature gauge, hour meter and fuel gauge. Indicators are provided for crane level, load moment, drum rotation, air filter restriction, hydraulic oil temperature and filter restriction, engine oil pressure and temperature.

Engine

- Make/ Model: Cummins QSX15
- Emissions: EPA Tier III
- Rating: 600 hp @ 2100 RPM

Electrical System

12 VDC

Counterweight

Total 30,000 lbs (13.6t) rear counterweight (Two pieces – 15,000 lbs (6.8t) each). Counterweight raised and lowered by counterweight removal winch.

Swing

Dual Swing Drives - Gear motor driving a planetary gear reducer with a shaft mounted pinion, external gear shear ball slew bearing bolted to the superstructure and the carbody allows the superstructure to rotate 360°. Selectable swing mode: Free swing or cushion lock swing.

- Swing Speed: 0 – 1.6 rpm

- Swing Parking Brake: Spring applied failsafe brake with hydraulic release that is controlled from the operators cab
- Swing Service Brake: Hydraulically applied, controlled through foot actuated pedal
- House Lock System: 2-position, manually pinned

Hydraulic System

- Hydraulic Pumps: Two high pressure, variable axial piston pumps with load sense and power limiting control for crane functions. One variable axial piston pump for cooling loop
- Directional Valves: Multiple pressure and flow compensated valves with integrated relief valves controlled by hydraulic pilot signals.
- Pump output: 300 gal/min (1,135 lpm) @ 2100 RPM engine speed. 330 bar maximum pressure
- Filtration: 5 micron.

Side Frames

Two welded steel side frames are paired with a track group. The side frames extend and retract hydraulically and are controlled from the cab.

- Track Rollers: One top and thirteen bottom sealed rollers on each track frame
- Idler: Oil filled, self lubricating with spring type tensioner
- Track Drives: Tandem track drives mounted in each side frame.
- Track Shoes: 33.5 inch (850 mm) 3-bar semi grouser

Recovery Winch

Carco H140 – 140,000 lb (622 kN) line pull winch mounted to undercarriage.

Miscellaneous Items

- Boom Lights: Two worklights mounted on boom base section, gravity hung to light ground work area.
- Foldable handrails around crane upper rotating frame.

WEIGHTS AND DIMENSIONS

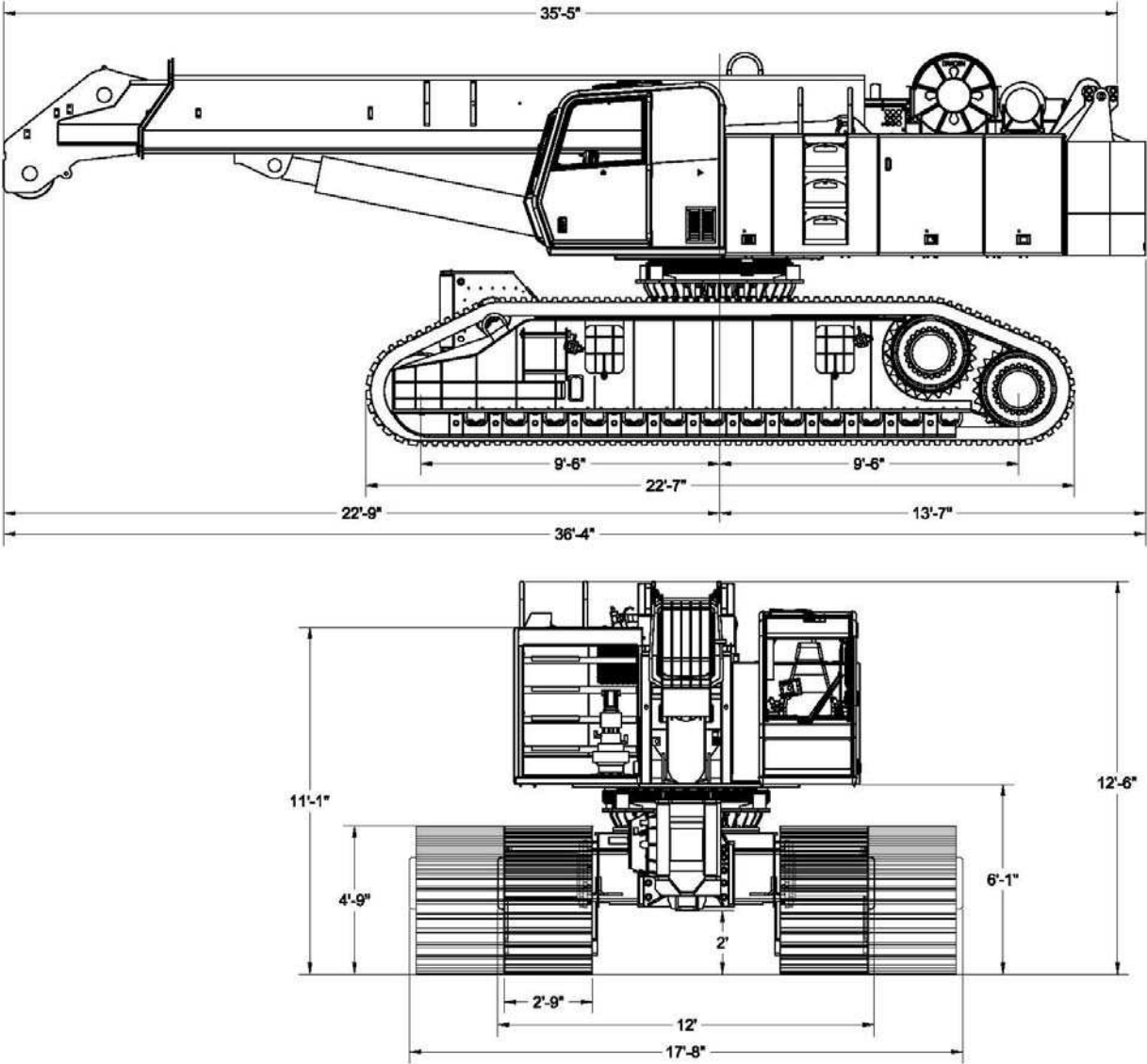

WEIGHTS

STANDARD CRANE WITH 3-SECTION 54 FOOT BOOM, COUNTERWEIGHT, AND 33 INCH TRACK SHOES	153,000 LBS (69,400 kg)
TRACK FRAMES (2 AT 23,930 LBS (10,855 kg) EACH)	47,840 LBS (21,700 kg)
COUNTERWEIGHT (2 PIECES AT 15,000 LBS (6.8t) EACH)	30,000 LBS (13.6t)

NOTES:

TADANO MANTIS CORPORATION
1705 Columbia Avenue, Suite 200
Franklin, Tennessee 37064

www.mantiscranes.com

200RS-0113