

ALL-TERRAIN ATF 120-5

ISO 9001

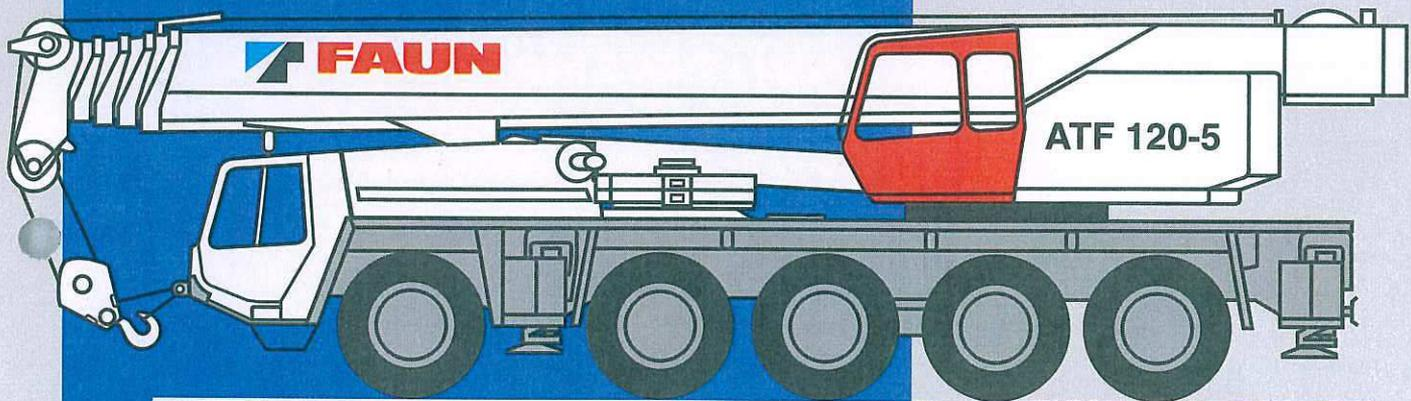

Maße / Dimensions / Dimensions / Dimensiones (mm)
 Gewichte / Weights / Poids / Pesos
 Geschwindigkeiten / Speeds / Vitesses / Velocidades

16.00 R 25

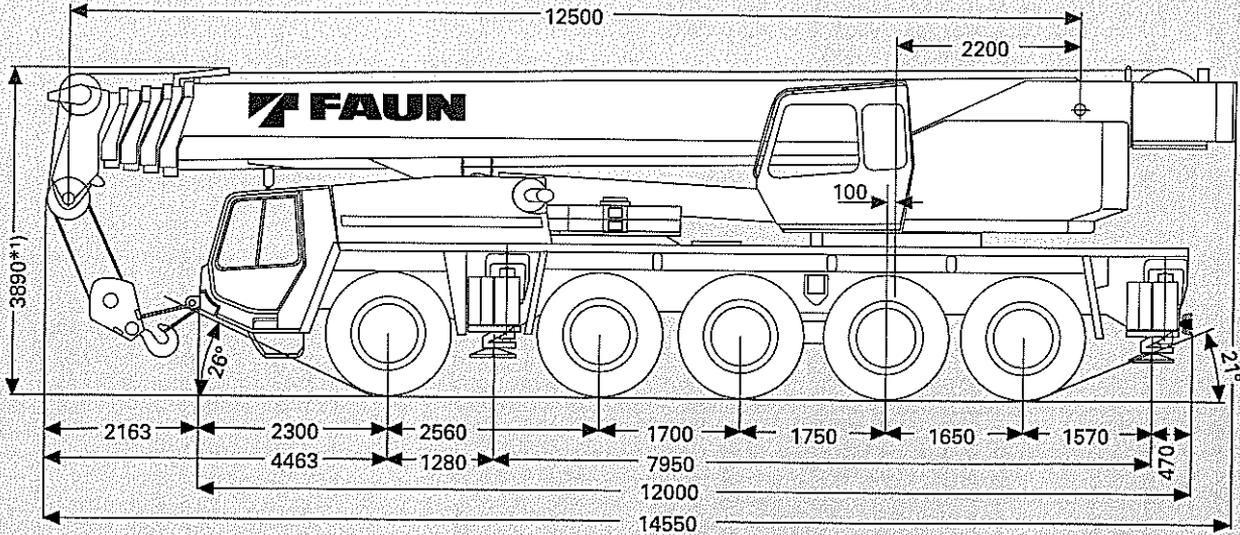

*1) -116 mm / + 152 mm

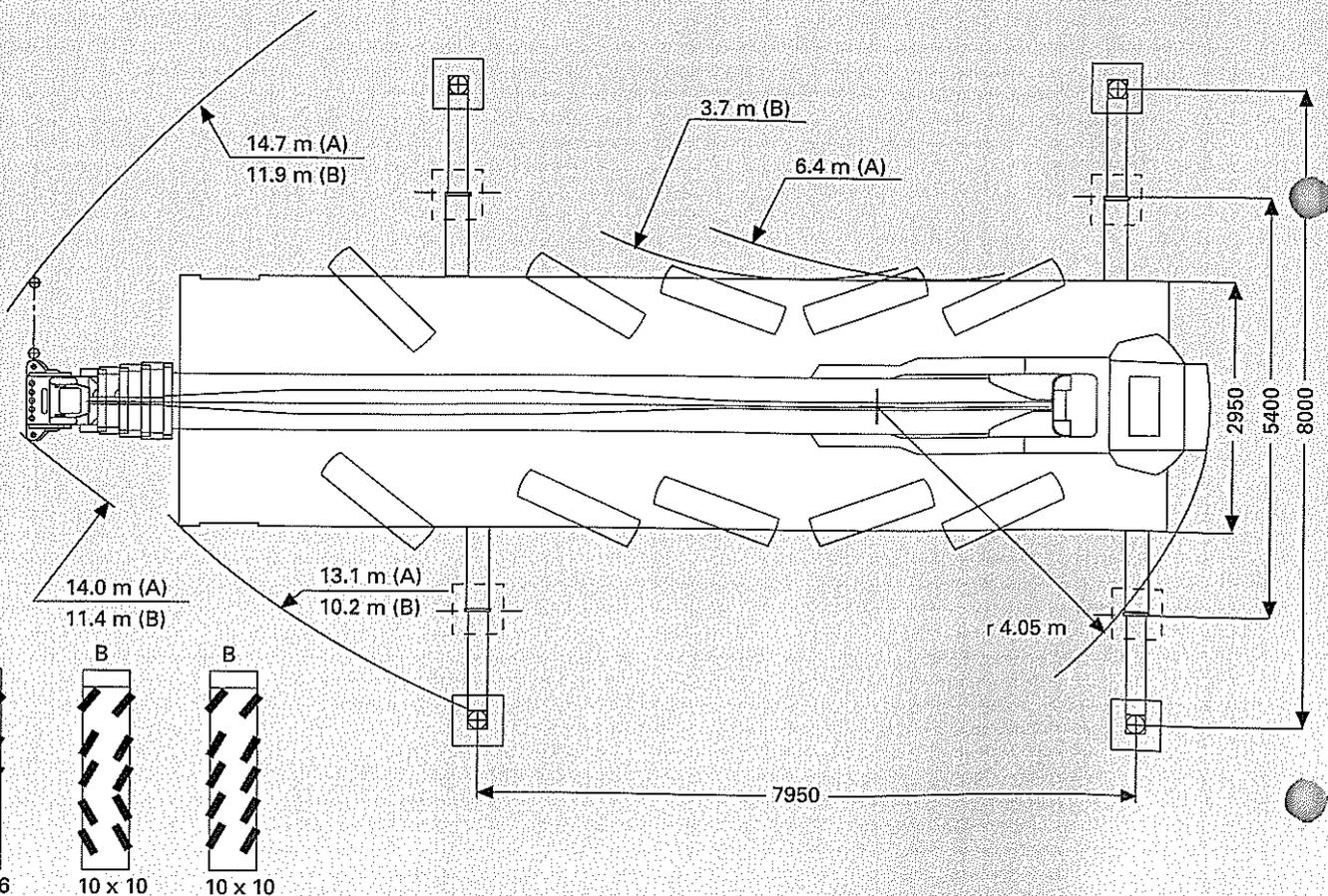

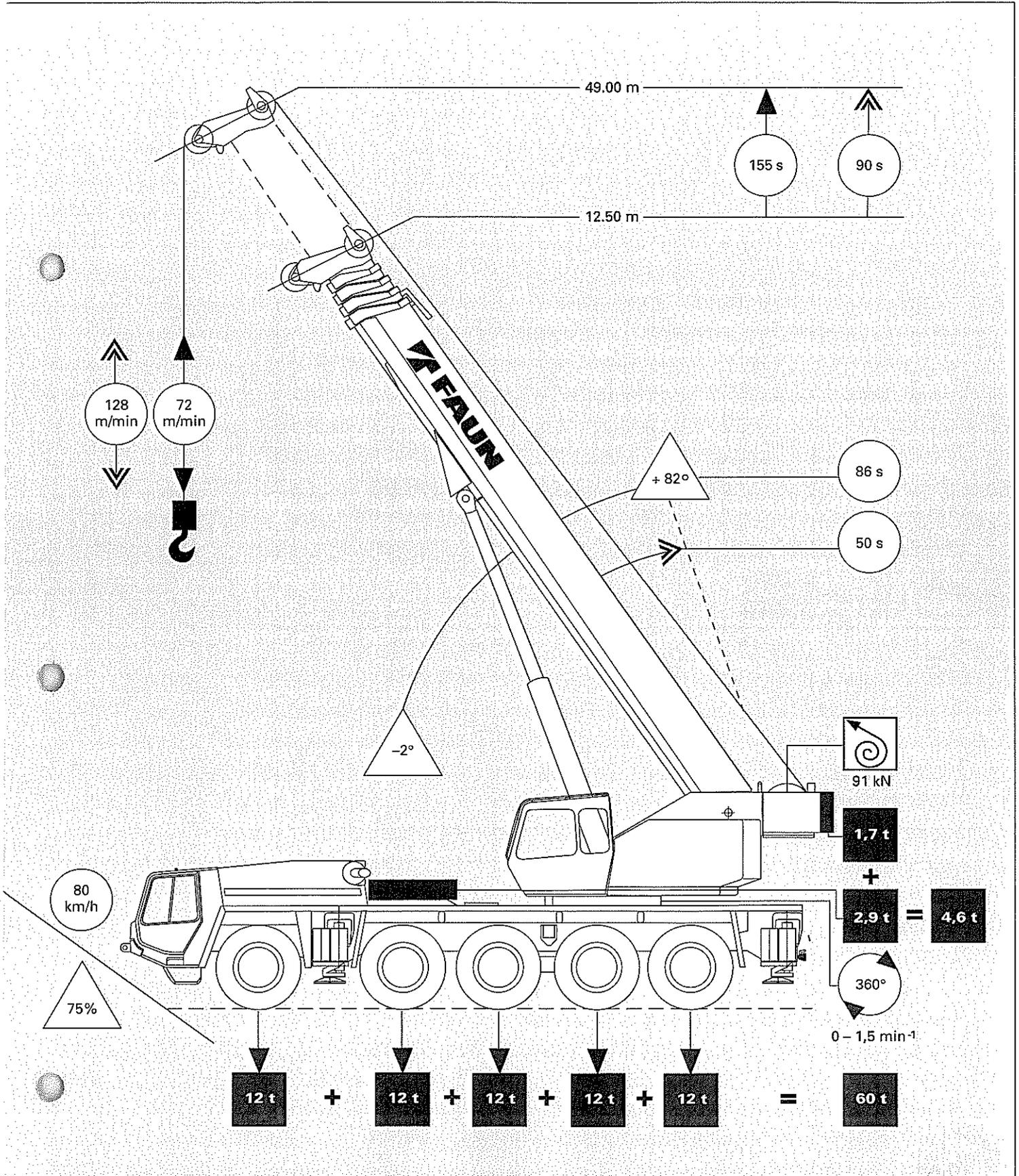

Tragfähigkeiten am Teleskopausleger
 Lifting capacities on telescoping boom
 Capacités de levage à la flèche télescopique
 Capacidades de elevación con la pluma telescópica



DIN

→ m	12.5 m**	12.5 m	21.65 m	21.65 m	30.75 m	30.75 m	39.90 m	39.90 m	49.00 m
3.0	130.0***	112.0	50.0	21.0					
3.5	110.0	103.0	50.0	21.0					
4.0	95.0	90.0	50.0	21.0	34.0	21.0			
4.5	86.0	81.0	50.0	21.0	34.0	21.0			
5.0	78.5	73.5	50.0	21.0	34.0	21.0			
6.0	67.0	62.5	50.0	21.0	34.0	21.0	21.0	21.0	
7.0	58.0	54.0	50.0	21.0	34.0	21.0	21.0	21.0	13.0
8.0	51.0	47.0	45.5	21.0	33.0	21.0	21.0	21.0	13.0
9.0	45.5	42.0	40.8	21.0	29.8	21.0	21.0	21.0	13.0
10.0			40.0	21.0	27.1	21.0	21.0	21.0	13.0
11.0			35.0	21.0	24.8	21.0	21.0	20.0	13.0
12.0			30.0	21.0	22.8	21.0	20.3	18.8	13.0
14.0			23.5	21.0	19.5	20.8	17.3	16.1	13.0
16.0			18.7	20.2	16.9	18.8	15.0	14.0	13.0
18.0			15.2	16.7	14.7	16.8	13.1	12.3	11.6
20.0					12.1	14.3	11.5	10.9	10.3
22.0					10.1	12.1	10.2	9.7	9.3
24.0					8.4	10.4	9.1	8.8	8.5
26.0					7.0	9.0	8.2	8.1	7.6
28.0					5.8	7.7	7.1	7.4	6.9
30.0							6.0	6.6	6.3
32.0							5.2	5.8	5.7
34.0							4.4	5.1	5.2
36.0							3.8	4.4	4.5
38.0									3.9
40.0									3.4
42.0									2.9
44.0									2.5
46.0									2.1
	I	0	50	25	100	50	100	75	100
	II	0	50	25	100	50	100	75	100
	III	0	0	25	0	50	50	75	100
	IV	0	0	25	0	50	50	75	100



85%

→ m	12.5 m**	12.5 m	21.65 m	21.65 m	30.75 m	30.75 m	39.90 m	39.90 m	49.00 m
3.0	140.0***	120.0***	55.0	23.0					
3.5	117.5***	110.1	55.0	23.0					
4.0	101.6	96.3	55.0	23.0	37.0	23.0			
4.5	92.0	86.7	55.0	23.0	37.0	23.0			
5.0	84.0	78.7	55.0	23.0	37.0	23.0			
6.0	71.8	67.0	55.0	23.0	37.0	23.0	23.0	23.0	
7.0	62.3	58.0	55.0	23.0	37.0	23.0	23.0	23.0	14.5
8.0	54.8	50.6	49.0	23.0	35.8	23.0	23.0	23.0	14.5
9.0	49.0	45.3	44.1	23.0	32.4	23.0	23.0	23.0	14.5
10.0			43.2	23.0	29.5	23.0	23.0	23.0	14.5
11.0			37.9	23.0	27.1	23.0	23.0	21.8	14.5
12.0			32.6	23.0	25.0	23.0	22.2	20.5	14.5
14.0			25.7	23.0	21.5	22.7	19.0	17.7	14.5
16.0			20.6	22.1	18.7	20.6	16.6	15.4	14.5
18.0			16.9	18.3	16.4	18.4	14.6	13.6	12.9
20.0					13.6	15.8	12.9	12.2	11.5
22.0					11.5	13.4	11.5	10.9	10.5
24.0					9.7	11.6	10.3	9.9	9.6
26.0					8.1	10.1	9.3	9.2	8.6
28.0					6.7	8.8	8.2	8.4	7.9
30.0							6.9	7.6	7.2
32.0							6.0	6.7	6.6
34.0							5.1	5.9	6.0
36.0							4.4	5.1	5.2
38.0									4.5
40.0									3.9
42.0									3.3
44.0									2.9
46.0									2.4
	I	0	50	25	100	50	100	75	100
	II	0	50	25	100	50	100	75	100
	III	0	0	25	0	50	50	75	100
	IV	0	0	25	0	50	50	75	100

Hubhöhen
Lifting heights
Hauteurs de levage
Alturas de elevación

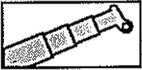

29,4 t

DIN

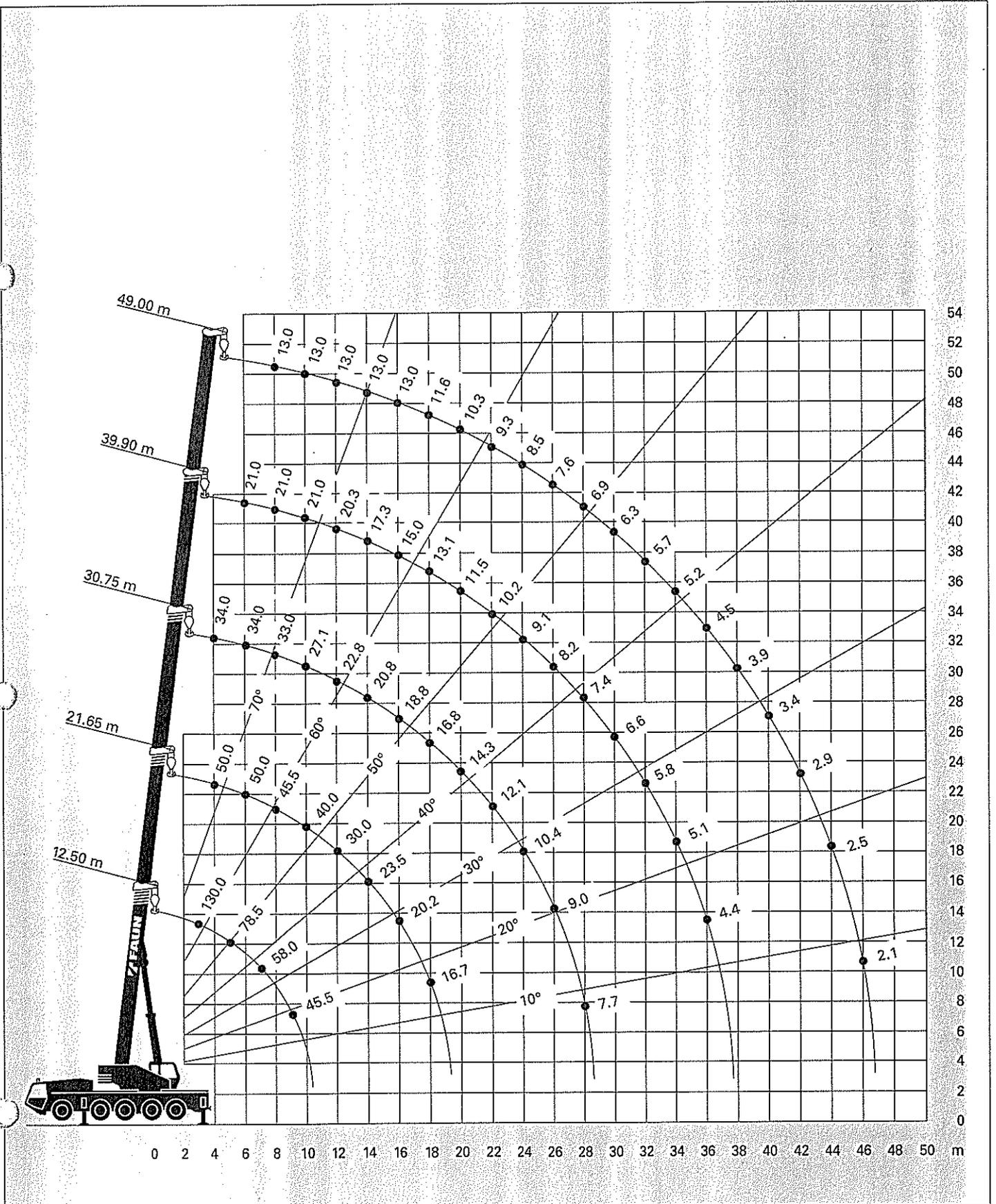

***) Nach hinten
****) Mit Zusatzverkleidung

***) Over rear
****) With additional equipment

***) A l'arrière
****) Avec équipement supplémentaire

***) Sobre la parte trasera
****) Con equipo adicional

Tragfähigkeiten am Teleskopausleger
 Lifting capacities on telescoping boom
 Capacités de levage à la flèche télescopique
 Capacidades de elevación con la pluma telescópica

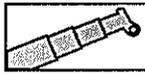

DIN

→ m	12.5 m**	12.5 m	21.65 m	21.65 m	30.75 m	30.75 m	39.90 m	39.90 m	49.00 m
3.0	120.0***	110.0	50.0	21.0					
3.5	105.0	98.0	50.0	21.0					
4.0	90.0	87.0	50.0	21.0	34.0	21.0			
4.5	81.5	78.0	50.0	21.0	34.0	21.0			
5.0	74.0	70.5	50.0	21.0	34.0	21.0			
6.0	62.0	58.1	50.0	21.0	34.0	21.0	21.0	21.0	
7.0	52.7	49.7	50.0	21.0	34.0	21.0	21.0	21.0	13.0
8.0	45.8	43.0	45.5	21.0	33.0	21.0	21.0	21.0	13.0
9.0	40.0	37.1	40.8	21.0	29.8	21.0	21.0	21.0	13.0
10.0			34.0	21.0	27.1	21.0	21.0	21.0	13.0
11.0			28.9	21.0	24.8	21.0	21.0	20.0	13.0
12.0			24.7	21.0	22.8	21.0	20.3	18.8	13.0
14.0			18.9	21.0	18.3	20.8	17.3	16.1	13.0
16.0			14.8	16.2	14.4	16.7	15.0	14.0	13.0
18.0			11.8	13.3	11.4	13.6	12.9	12.3	11.6
20.0					9.2	11.3	10.7	10.9	10.3
22.0					7.4	9.4	8.8	9.5	9.3
24.0					6.0	8.0	7.4	8.1	8.2
26.0					4.9	6.9	6.2	6.9	6.9
28.0					3.9	5.8	5.2	5.8	5.9
30.0							4.3	4.9	5.0
32.0							3.6	4.2	4.3
34.0							2.9	3.6	3.6
36.0							2.3	3.0	3.0
38.0									2.5
40.0									2.1
42.0									1.7
44.0									1.3
%	I	0	50	25	100	50	100	75	100
	II	0	50	25	100	50	100	75	100
	III	0	0	25	0	50	50	75	100
	IV	0	0	0	25	0	50	75	100

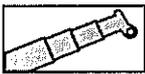

85%

→ m	12.5 m**	12.5 m	21.65 m	21.65 m	30.75 m	30.75 m	39.90 m	39.90 m	49.00 m
3.0	130.0***	117.5***	55.0	23.0					
3.5	112.0	104.7	55.0	23.0					
4.0	96.2	93.0	55.0	23.0	37.0	23.0			
4.5	87.2	83.5	55.0	23.0	37.0	23.0			
5.0	79.2	75.5	55.0	23.0	37.0	23.0			
6.0	66.5	62.3	55.0	23.0	37.0	23.0	23.0	23.0	
7.0	56.6	53.4	55.0	23.0	37.0	23.0	23.0	23.0	14.5
8.0	49.3	46.3	49.0	23.0	35.8	23.0	23.0	23.0	14.5
9.0	43.1	40.0	44.0	23.0	32.4	23.0	23.0	23.0	14.5
10.0			36.7	23.0	29.5	23.0	23.0	23.0	14.5
11.0			31.4	23.0	27.0	23.0	23.0	21.8	14.5
12.0			26.9	23.0	24.9	23.0	22.2	20.5	14.5
14.0			20.8	23.0	20.2	22.6	19.0	17.7	14.5
16.0			16.4	17.8	16.0	18.3	16.6	15.4	14.5
18.0			13.2	14.7	12.8	15.0	14.3	13.6	12.9
20.0					10.5	12.6	12.0	12.2	11.5
22.0					8.5	10.6	10.0	10.7	10.5
24.0					6.9	9.1	8.5	9.2	9.3
26.0					5.6	7.9	7.1	7.9	7.9
28.0					4.5	6.7	6.0	6.7	6.8
30.0							5.0	5.6	5.8
32.0							4.1	4.8	5.0
34.0							3.4	4.1	4.1
36.0							2.7	3.5	3.5
38.0									2.9
40.0									2.4
42.0									2.0
44.0									1.6
46.0									1.2
%	I	0	50	25	100	50	100	75	100
	II	0	50	25	100	50	100	75	100
	III	0	0	25	0	50	50	75	100
	IV	0	0	0	25	0	50	75	100

Hubhöhen
Lifting heights
Hauteurs de levage
Alturas de elevación

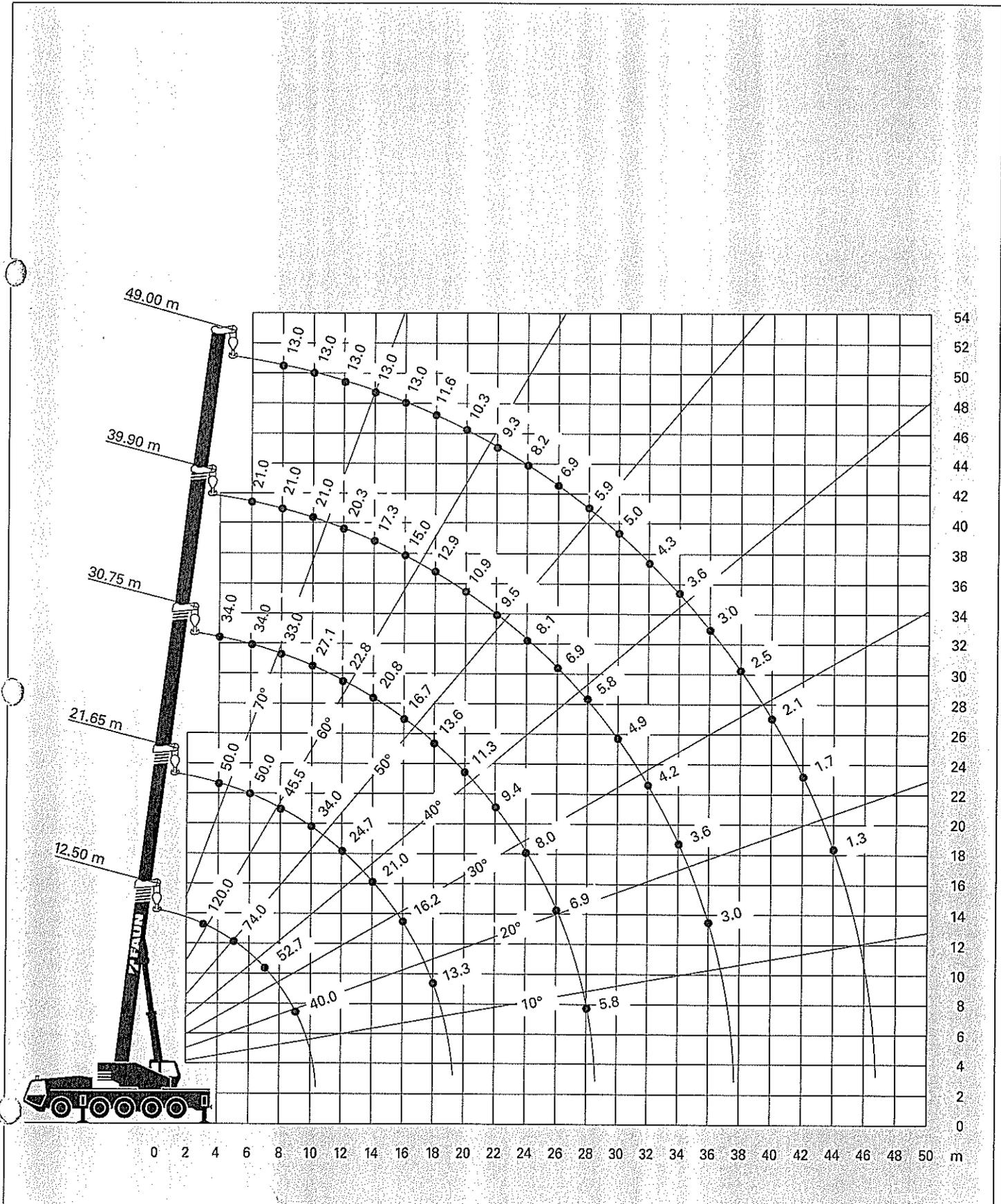
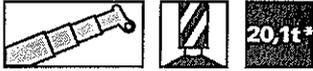

*] Gegen Mehrpreis *) Against extra charge *) Contre supplément de prix *) Con suplemento de precio
 **) Nach hinten **) Over rear **) A l'arrière **) Sobre la parte trasera

Tragfähigkeiten am Teleskopausleger
 Lifting capacities on telescoping boom
 Capacités de levage à la flèche télescopique
 Capacidades de elevación con la pluma telescópica

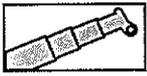

9,1t*

DIN

→ m	12.5 m	21.65 m	21.65 m	30.75 m	30.75 m	39.90 m	39.90 m	49.00 m	
3.0	110.0	50.0	21.0						
3.5	98.0	50.0	21.0						
4.0	87.0	50.0	21.0	34.0	21.0				
4.5	78.0	50.0	21.0	34.0	21.0				
5.0	70.5	50.0	21.0	34.0	21.0				
6.0	58.1	50.0	21.0	34.0	21.0	21.0	21.0		
7.0	49.7	49.3	21.0	34.0	21.0	21.0	21.0	13.0	
8.0	40.2	38.7	21.0	33.0	21.0	21.0	21.0	13.0	
9.0	32.0	31.2	21.0	29.8	21.0	21.0	21.0	13.0	
10.0	26.3	25.8	21.0	25.3	21.0	21.0	21.0	13.0	
11.0		21.8	21.0	21.2	21.0	21.0	20.0	13.0	
12.0		18.5	20.3	18.0	20.6	19.7	18.8	13.0	
14.0		14.0	15.6	13.5	15.8	15.0	15.8	13.0	
16.0		10.7	12.2	10.2	12.4	11.7	12.5	12.6	
18.0		8.0	9.6	7.6	9.9	9.2	10.0	10.1	
20.0				5.6	7.9	7.1	8.0	8.1	
22.0				4.1	6.3	5.5	6.4	6.4	
24.0				2.9	5.1	4.3	5.2	5.2	
26.0				1.9	4.0	3.3	4.1	4.1	
28.0				1.0	3.1	2.4	3.2	3.3	
30.0						1.7	2.5	2.5	
32.0						1.1	1.9	2.0	
34.0							1.3	1.4	
36.0							0.9	0.9	
38.0									
40.0									
42.0									
44.0									
	I	0	50	25	100	50	100	75	100
	II	0	50	25	100	50	100	75	100
	III	0	0	25	0	50	50	75	100
	IV	0	0	25	0	50	50	75	100

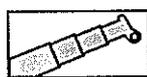

9,1t*

85%

→ m	12.50 m	21.65 m	21.65 m	30.75 m	30.75 m	39.90 m	39.90 m	49.00 m	
3.0	117.5***	55.0	23.0						
3.5	104.7	55.0	23.0						
4.0	93.0	55.0	23.0	37.0	23.0				
4.5	83.5	55.0	23.0	37.0	23.0				
5.0	75.5	55.0	23.0	37.0	23.0				
6.0	62.3	55.0	23.0	37.0	23.0	23.0	23.0		
7.0	53.4	53.0	23.0	37.0	23.0	23.0	23.0	14.5	
8.0	43.3	41.8	23.0	35.8	23.0	23.0	23.0	14.5	
9.0	34.6	33.9	23.0	32.4	23.0	23.0	23.0	14.5	
10.0	28.6	28.1	23.0	27.5	23.0	23.0	23.0	14.5	
11.0		23.9	23.0	23.1	23.0	23.0	21.8	14.5	
12.0		20.4	22.2	19.7	22.5	21.5	20.5	14.5	
14.0		15.6	17.2	14.9	17.4	16.6	17.4	14.5	
16.0		12.1	13.6	11.4	13.8	13.1	13.9	14.0	
18.0		9.2	10.8	8.7	11.1	10.4	11.2	11.3	
20.0				6.5	9.0	8.2	9.1	9.2	
22.0				4.7	7.2	6.3	7.4	7.4	
24.0				3.4	5.9	5.0	6.0	6.0	
26.0				2.3	4.6	3.8	4.7	4.7	
28.0				1.3	3.6	2.8	3.7	3.8	
30.0						2.0	2.9	2.9	
32.0						1.3	2.2	2.3	
34.0						0.7	1.6	1.7	
36.0							1.2	1.2	
38.0									
40.0									
42.0									
44.0									
46.0									
	I	0	50	25	100	50	100	75	100
	II	0	50	25	100	50	100	75	100
	III	0	0	25	0	50	50	75	100
	IV	0	0	25	0	50	50	75	100

Hubhöhen
Lifting heights
Hauteurs de levage
Alturas de elevación

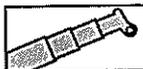

9.1t*

DIN

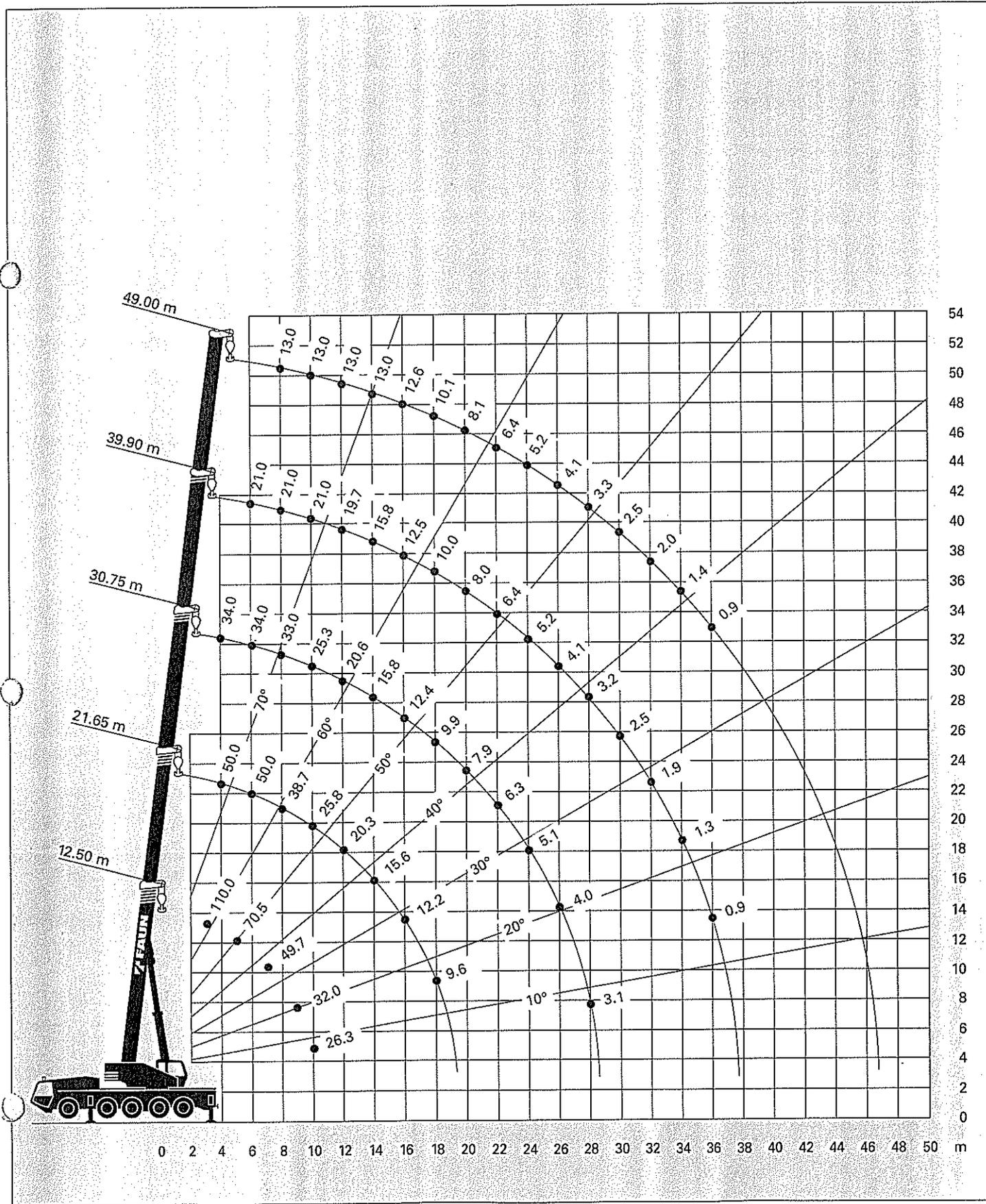

*) Gegen Mehrpreis

*) Against extra charge

*) Contre supplément de prix

*) Con suplemento de precio

Tragfähigkeiten am Teleskopausleger
 Lifting capacities on telescoping boom
 Capacités de levage à la flèche télescopique
 Capacidades de elevación con la pluma telescópica



DIN

→ m	12.50 m	21.65 m	21.65 m	30.75 m	30.75 m	39.90 m	39.90 m	49.00 m
3.0	110.0	50.0	21.0					
3.5	98.0	50.0	21.0					
4.0	87.0	50.0	21.0	34.0	21.0			
4.5	78.0	50.0	21.0	34.0	21.0			
5.0	70.5	50.0	21.0	34.0	21.0			
6.0	58.1	50.0	21.0	34.0	21.0	21.0	21.0	
7.0	45.5	45.0	21.0	34.0	21.0	21.0	21.0	13.0
8.0	35.8	34.5	21.0	33.0	21.0	21.0	21.0	13.0
9.0	28.7	27.5	21.0	27.0	21.0	21.0	21.0	13.0
10.0	23.7	22.5	21.0	22.0	21.0	21.0	21.0	13.0
11.0		18.8	20.7	18.3	20.8	20.1	20.0	13.0
12.0		15.9	17.6	15.4	17.8	17.1	18.0	13.0
14.0		11.2	13.1	10.7	13.3	12.5	13.5	13.0
16.0		7.9	9.7	7.4	9.9	9.1	10.0	10.1
18.0		5.6	7.2	5.2	7.5	6.7	7.6	7.7
20.0				3.5	5.7	5.0	5.8	5.9
22.0				2.2	4.3	3.6	4.4	4.5
24.0				1.2	3.3	2.6	3.4	3.5
26.0					2.4	1.7	2.5	2.6
28.0					1.6	1.0	1.8	1.9
30.0							1.2	1.3
32.0							0.7	0.7
34.0								
36.0								
38.0								
40.0								
42.0								
44.0								
%	I 0 II 0 III 0 IV 0	50 50 0 0	25 25 25 25	100 100 0 0	50 50 50 50	100 100 50 50	75 75 75 75	100 100 100 100



85%

→ m	12.50 m	21.65 m	21.65 m	30.75 m	30.75 m	39.90 m	39.90 m	49.00 m
3.0	117.5***	55.0	23.0					
3.5	104.7	55.0	23.0					
4.0	93.0	55.0	23.0	37.0	23.0			
4.5	83.5	55.0	23.0	37.0	23.0			
5.0	75.5	55.0	23.0	37.0	23.0			
6.0	62.3	55.0	23.0	37.0	23.0	23.0	23.0	
7.0	49.0	48.5	23.0	37.0	23.0	23.0	23.0	14.5
8.0	38.7	37.4	23.0	35.8	23.0	23.0	23.0	14.5
9.0	31.1	29.9	23.0	29.4	23.0	23.0	23.0	14.5
10.0	25.8	24.6	23.0	24.1	22.7	23.0	23.0	14.5
11.0		20.7	22.6	20.2	19.5	22.0	21.8	14.5
12.0		17.6	19.3	17.1	14.7	18.8	19.7	14.5
14.0		12.6	14.5	12.1	11.1	13.9	14.9	14.5
16.0		9.1	10.9	8.5	8.5	10.3	11.2	11.3
18.0		6.5	8.2	6.0	6.6	7.7	8.7	8.7
20.0				4.0	5.0	5.8	6.7	6.8
22.0				2.6	3.8	4.2	5.1	5.2
24.0				1.5	2.8	3.0	4.0	4.1
26.0				0.7	1.9	2.0	2.9	3.0
28.0						1.3	2.1	2.2
30.0						0.7	1.5	1.6
32.0							0.9	1.0
34.0								
36.0								
38.0								
40.0								
42.0								
44.0								
46.0								
%	I 0 II 0 III 0 IV 0	50 50 0 0	25 25 25 25	100 100 0 0	50 50 50 50	100 100 50 50	75 75 75 75	100 100 100 100

Hubhöhen
Lifting heights
Hauteurs de levage
Alturas de elevación

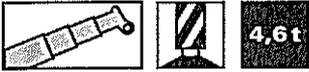

DIN

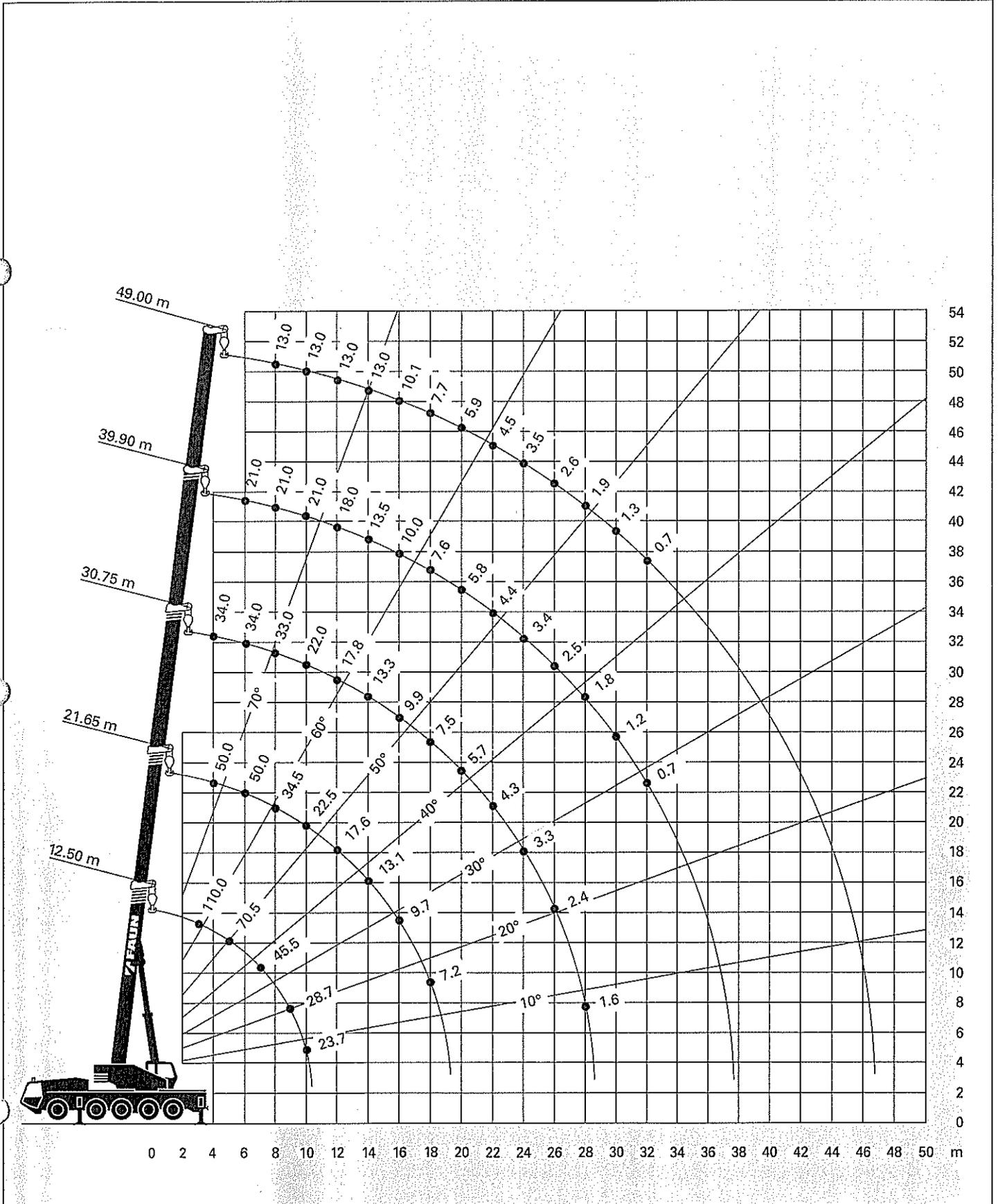

Tragfähigkeiten an der Spitze*
 Lifting capacities on boom extension*
 Capacités de levage à la rallonge de flèche*
 Capacidades de elevación con plumín*

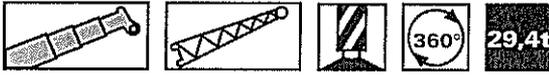

DIN

→ m	43.5 m + 9.5 m			49.0 m + 9.5 m			49.0 m + 16.2 m			49.0 m + 24.1 m			49.0 m + 30.1 m		
	5°	15°	30°	5°	15°	30°	5°	15°	30°	5°	15°	30°	5°	15°	30°
10.0	10.00			7.50											
11.0	10.00			7.50											
12.0	10.00	7.20		7.50	6.50		5.50								
14.0	9.40	7.20	5.20	7.50	6.50	5.00	5.50	4.20							
16.0	8.75	6.95	5.20	7.50	6.50	5.00	5.50	4.20	3.20						
18.0	8.15	6.70	5.05	7.05	6.20	5.00	5.25	4.20	3.10	3.00					
20.0	7.55	6.45	4.95	6.65	5.95	4.90	5.05	4.05	3.00	2.85	2.45		2.00		
22.0	6.85	6.05	4.80	6.20	5.65	4.75	4.80	3.85	2.95	2.70	2.30		2.00		
24.0	6.25	5.70	4.60	5.60	5.40	4.65	4.55	3.70	2.85	2.55	2.15	1.70	1.85	1.55	
26.0	5.75	5.40	4.40	5.10	4.95	4.50	4.20	3.50	2.75	2.40	2.00	1.60	1.65	1.40	
28.0	5.30	5.05	4.25	4.65	4.55	4.40	3.85	3.35	2.70	2.20	1.85	1.55	1.50	1.30	
30.0	4.85	4.70	4.10	4.20	4.20	4.10	3.50	3.15	2.60	2.05	1.75	1.45	1.40	1.25	1.05
32.0	4.30	4.40	4.00	3.80	3.85	3.80	3.25	3.00	2.50	1.90	1.65	1.40	1.30	1.15	1.00
34.0	3.85	4.10	3.85	3.45	3.60	3.55	3.00	2.85	2.40	1.75	1.55	1.30	1.15	1.05	0.95
36.0	3.40	3.65	3.75	3.15	3.30	3.30	2.75	2.75	2.35	1.65	1.45	1.25	1.10	1.00	0.90
38.0	3.00	3.20	3.45	2.85	3.00	3.05	2.55	2.55	2.25	1.55	1.35	1.20	1.00	0.90	0.85
40.0	2.65	2.85	3.00	2.50	2.75	2.85	2.35	2.40	2.20	1.45	1.30	1.15	0.90	0.85	0.80
42.0	2.35	2.50	2.65	2.20	2.40	2.60	2.20	2.20	2.10	1.35	1.25	1.10	0.85	0.80	0.75
44.0	1.95	2.15	2.25	1.90	2.10	2.35	2.05	2.05	2.05	1.25	1.15	1.05	0.80	0.75	0.70
46.0	1.70	1.80	1.80	1.60	1.80	1.95	1.90	1.95	1.95	1.20	1.10	1.00	0.70	0.70	
48.0	1.35	1.35	1.35	1.30	1.50	1.65	1.75	1.80	1.85	1.15	1.05	0.95			
50.0	1.00	1.00		1.20	1.30	1.30	1.55	1.70	1.70	1.05	1.00	0.90			
52.0				0.90	0.95	0.90	1.35	1.50	1.55	1.00	0.95	0.85			
54.0							1.15	1.30	1.40	0.95	0.90	0.80			
56.0							1.00	1.05	1.15	0.90	0.85	0.80			
58.0							0.75	0.80	0.85	0.85	0.80	0.75			
60.0										0.80	0.75	0.70			
	I	100			100			100			100			100	
	II	100			100			100			100			100	
	III	70			100			100			100			100	
	IV	70			100			100			100			100	

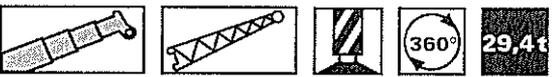

85%

→ m	43.5 m + 9.5 m			49.0 m + 9.5 m			49.0 m + 16.2 m			49.0 m + 24.1 m			49.0 m + 30.1 m		
	5°	15°	30°	5°	15°	30°	5°	15°	30°	5°	15°	30°	5°	15°	30°
10.0	11.50			8.60											
11.0	11.50			8.60											
12.0	11.50	8.30		8.60	7.50		6.35								
14.0	10.60	8.30	6.00	8.60	7.50	5.75	6.35	4.85							
16.0	9.90	8.00	6.00	8.60	7.50	5.75	6.35	4.85	3.70						
18.0	9.30	7.70	5.80	8.10	7.15	5.75	6.05	4.85	3.55	3.45					
20.0	8.60	7.40	5.70	7.65	6.85	5.65	5.80	4.65	3.45	3.30	2.80		2.30		
22.0	7.90	6.95	5.50	7.15	6.50	5.45	5.50	4.45	3.40	3.10	2.65		2.30		
24.0	7.20	6.55	5.30	6.45	6.20	5.35	5.25	4.25	3.30	2.95	2.45	1.95	2.15	1.80	
26.0	6.60	6.20	5.05	5.85	5.70	5.20	4.85	4.05	3.15	2.75	2.30	1.85	1.90	1.60	
28.0	6.10	5.80	4.90	5.35	5.25	5.05	4.45	3.85	3.10	2.55	2.15	1.80	1.75	1.50	
30.0	5.60	5.40	4.70	4.85	4.85	4.70	4.05	3.65	3.00	2.35	2.00	1.65	1.60	1.45	1.20
32.0	4.95	5.05	4.60	4.35	4.45	4.35	3.75	3.45	2.90	2.20	1.90	1.60	1.50	1.35	1.15
34.0	4.45	4.70	4.45	3.95	4.15	4.10	3.45	3.30	2.75	2.00	1.80	1.50	1.30	1.20	1.10
36.0	3.90	4.20	4.30	3.60	3.80	3.80	3.15	3.15	2.70	1.90	1.70	1.45	1.25	1.15	1.05
38.0	3.45	3.70	3.95	3.30	3.45	3.50	2.95	2.95	2.60	1.80	1.55	1.40	1.15	1.05	1.00
40.0	3.05	3.30	3.45	2.90	3.15	3.30	2.70	2.75	2.55	1.65	1.50	1.35	1.05	1.00	0.95
42.0	2.65	2.90	3.05	2.55	2.75	3.00	2.55	2.55	2.45	1.55	1.45	1.30	1.00	0.95	0.90
44.0	2.30	2.45	2.60	2.20	2.40	2.70	2.35	2.35	2.35	1.45	1.30	1.20	0.90	0.85	0.80
46.0	1.95	2.05	2.05	1.85	2.05	2.25	2.20	2.25	2.25	1.40	1.25	1.15	0.80	0.80	
48.0	1.55	1.55	1.55	1.55	1.70	1.90	2.00	2.10	2.15	1.30	1.20	1.10			
50.0	1.20	1.20		1.45	1.55	1.55	1.80	1.95	1.95	1.20	1.15	1.05			
52.0				1.10	1.20	1.10	1.55	1.75	1.80	1.15	1.10	1.00			
54.0							1.35	1.50	1.60	1.10	1.05	0.95			
56.0							1.20	1.25	1.35	1.05	1.00	0.90			
58.0							0.90	0.95	1.00	1.00	0.95	0.85			
60.0										0.95	0.90	0.80			
	I	100			100			100			100			100	
	II	100			100			100			100			100	
	III	70			100			100			100			100	
	IV	70			100			100			100			100	

Hubhöhen
Lifting heights
Hauteurs de levage
Alturas de elevación

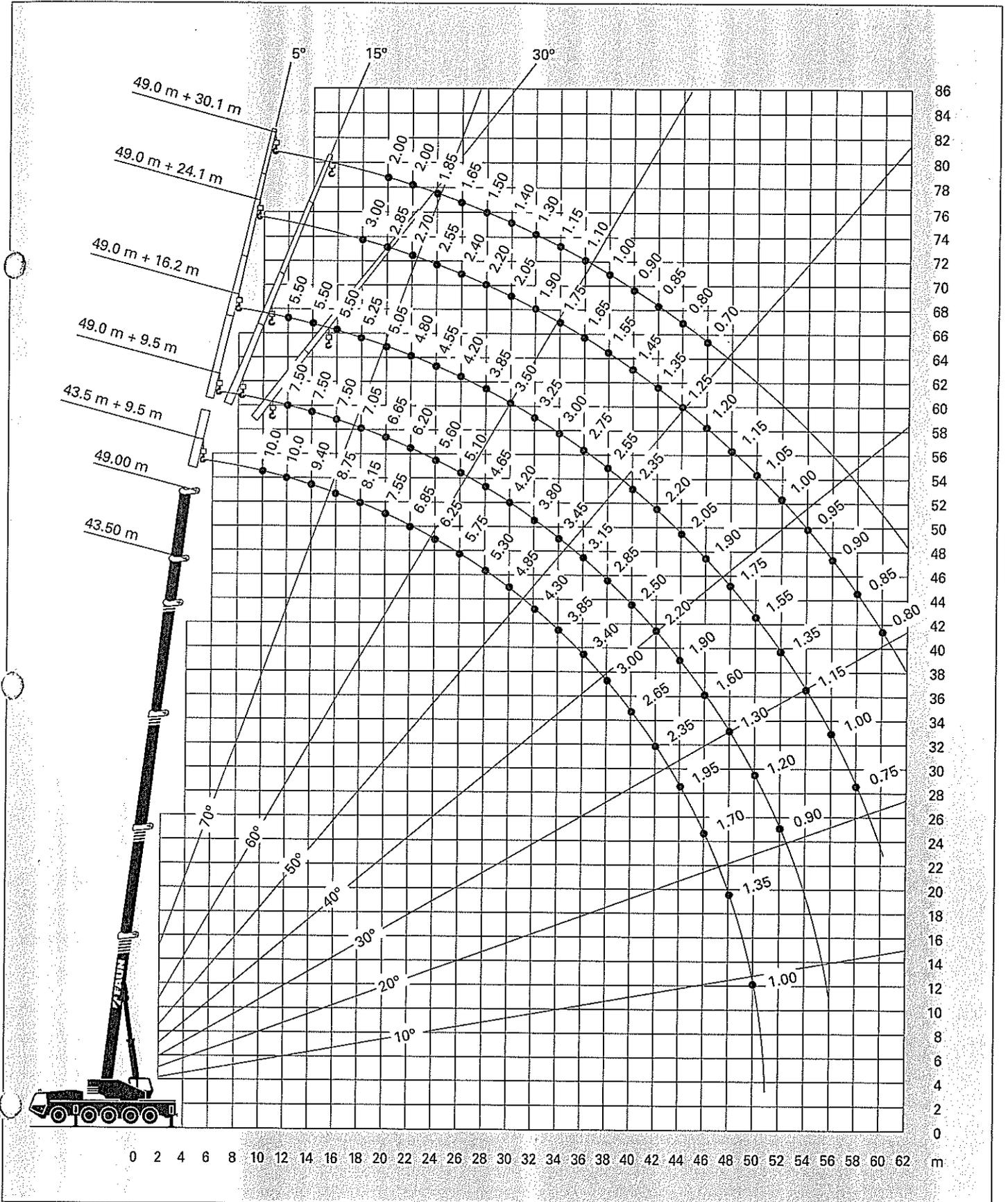
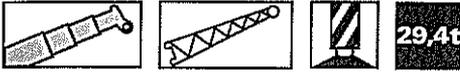

*) Gegen Mehrpreis

*) Against extra charge

*) Contre supplément de prix

*) Con suplemento de precio

Tragfähigkeiten an der Spitze*
 Lifting capacities on boom extension*
 Capacités de levage à la rallonge de flèche*
 Capacidades de elevación con plumín*

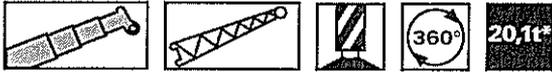

DIN

→ m	43.5 m + 9.5 m			49.0 m + 9.5 m			49.0 m + 16.2 m			49.0 m + 24.1 m			49.0 m + 30.1 m			
	5°	15°	30°	5°	15°	30°	5°	15°	30°	5°	15°	30°	5°	15°	30°	
10.0	10.00			7.50												
11.0	10.00			7.50												
12.0	10.00	7.20		7.50	6.50		5.50									
14.0	9.40	7.20	5.20	7.50	6.50	5.00	5.50	4.20								
16.0	8.75	6.95	5.20	7.50	6.50	5.00	5.50	4.20	3.20							
18.0	8.15	6.70	5.05	7.05	6.20	5.00	5.25	4.20	3.10	3.00						
20.0	7.55	6.45	4.95	6.65	5.95	4.90	5.05	4.05	3.00	2.85	2.45		2.00			
22.0	6.85	6.05	4.80	6.20	5.65	4.75	4.80	3.85	2.95	2.70	2.30		2.00			
24.0	6.25	5.70	4.60	5.60	5.40	4.65	4.55	3.70	2.85	2.55	2.15	1.70	1.85	1.55		
26.0	5.75	5.40	4.40	5.10	4.95	4.50	4.20	3.50	2.75	2.40	2.00	1.60	1.65	1.40		
28.0	5.30	5.05	4.25	4.65	4.55	4.40	3.85	3.35	2.70	2.20	1.85	1.55	1.50	1.30		
30.0	4.85	4.70	4.10	4.20	4.20	4.10	3.50	3.15	2.60	2.05	1.75	1.45	1.40	1.25	1.05	
32.0	4.05	4.25	4.00	3.80	3.85	3.80	3.25	3.00	2.50	1.90	1.65	1.40	1.30	1.15	1.00	
34.0	3.45	3.60	3.80	3.45	3.60	3.55	3.00	2.85	2.40	1.75	1.55	1.30	1.15	1.05	0.95	
36.0	2.80	2.95	3.15	3.05	3.20	3.30	2.75	2.75	2.35	1.65	1.45	1.25	1.10	1.00	0.90	
38.0	2.30	2.40	2.55	2.50	2.65	2.85	2.55	2.55	2.25	1.55	1.35	1.20	1.00	0.90	0.85	
40.0	1.80	1.90	2.05	2.00	2.15	2.30	2.35	2.40	2.20	1.45	1.30	1.15	0.90	0.85	0.80	
42.0	1.35	1.45	1.55	1.55	1.70	1.85	2.20	2.20	2.10	1.35	1.25	1.10	0.85	0.80	0.75	
44.0	0.95	1.05	1.10	1.15	1.25	1.40	1.85	2.05	2.05	1.25	1.15	1.05	0.80	0.75	0.70	
46.0				0.80	0.90	1.00	1.50	1.65	1.90	1.20	1.10	1.00	0.70			
48.0							1.20	1.35	1.50	1.15	1.05	0.95				
50.0							0.90	1.05	1.20	1.05	1.00	0.90				
52.0								0.75	0.90	1.00	0.95	0.85				
54.0										0.75	0.90	0.80				
56.0											0.70	0.75				
58.0																
60.0																
%	I	100			100			100			100			100		
	II	100			100			100			100			100		
	III	70			100			100			100			100		
	IV	70			100			100			100			100		

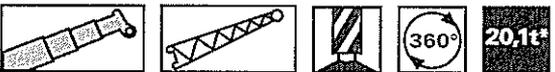

85%

→ m	43.5 m + 9.5 m			49.0 m + 9.5 m			49.0 m + 16.2 m			49.0 m + 24.1 m			49.0 m + 30.1 m			
	5°	15°	30°	5°	15°	30°	5°	15°	30°	5°	15°	30°	5°	15°	30°	
10.0	11.50			8.60												
11.0	11.50			8.60												
12.0	11.50	8.30		8.60	7.50		6.35									
14.0	10.60	8.30	6.00	8.60	7.50	5.75	6.35	4.85								
16.0	9.90	8.00	6.00	8.60	7.50	5.75	6.35	4.85	3.70							
18.0	9.30	7.70	5.80	8.10	7.15	5.75	6.05	4.85	3.55	3.45						
20.0	8.60	7.40	5.70	7.65	6.85	5.65	5.80	4.65	3.45	3.30	2.80		2.30			
22.0	7.90	6.95	5.50	7.15	6.50	5.45	5.50	4.45	3.40	3.10	2.65		2.30			
24.0	7.20	6.55	5.30	6.45	6.20	5.35	5.25	4.25	3.30	2.95	2.45	1.95	2.15	1.80		
26.0	6.60	6.20	5.05	5.85	5.70	5.20	4.85	4.05	3.15	2.75	2.30	1.85	1.90	1.60		
28.0	6.10	5.80	4.90	5.35	5.25	5.05	4.45	3.85	3.10	2.55	2.15	1.80	1.75	1.50		
30.0	5.60	5.40	4.70	4.85	4.85	4.70	4.05	3.65	3.00	2.35	2.00	1.65	1.60	1.45	1.20	
32.0	4.65	4.90	4.60	4.35	4.45	4.35	3.75	3.45	2.90	2.20	1.90	1.60	1.50	1.35	1.15	
34.0	3.95	4.15	4.35	3.95	4.15	4.10	3.45	3.30	2.75	2.00	1.80	1.50	1.30	1.20	1.10	
36.0	3.20	3.40	3.60	3.50	3.70	3.80	3.15	3.15	2.70	1.90	1.70	1.45	1.25	1.15	1.05	
38.0	2.65	2.80	2.95	2.90	3.05	3.30	2.95	2.95	2.60	1.80	1.55	1.40	1.15	1.05	1.00	
40.0	2.05	2.20	2.35	2.30	2.50	2.65	2.70	2.75	2.55	1.65	1.50	1.35	1.05	1.00	0.95	
42.0	1.55	1.70	1.80	1.80	1.95	2.15	2.55	2.55	2.45	1.55	1.45	1.30	1.00	0.95	0.90	
44.0	1.10	1.20	1.30	1.35	1.45	1.60	2.15	2.35	2.35	1.45	1.30	1.20	0.90	0.85	0.80	
46.0				0.95	1.05	1.15	1.75	1.90	2.15	1.40	1.25	1.15	0.80	0.80		
48.0							1.40	1.55	1.75	1.30	1.20	1.10				
50.0							1.10	1.25	1.40	1.20	1.15	1.05				
52.0								0.85	1.05	1.15	1.10	1.00				
54.0										0.90	1.05	0.95				
56.0											0.80	0.85				
58.0																
60.0																
%	I	100			100			100			100			100		
	II	100			100			100			100			100		
	III	70			100			100			100			100		
	IV	70			100			100			100			100		

Hubhöhen
Lifting heights
Hauteurs de levage
Alturas de elevación

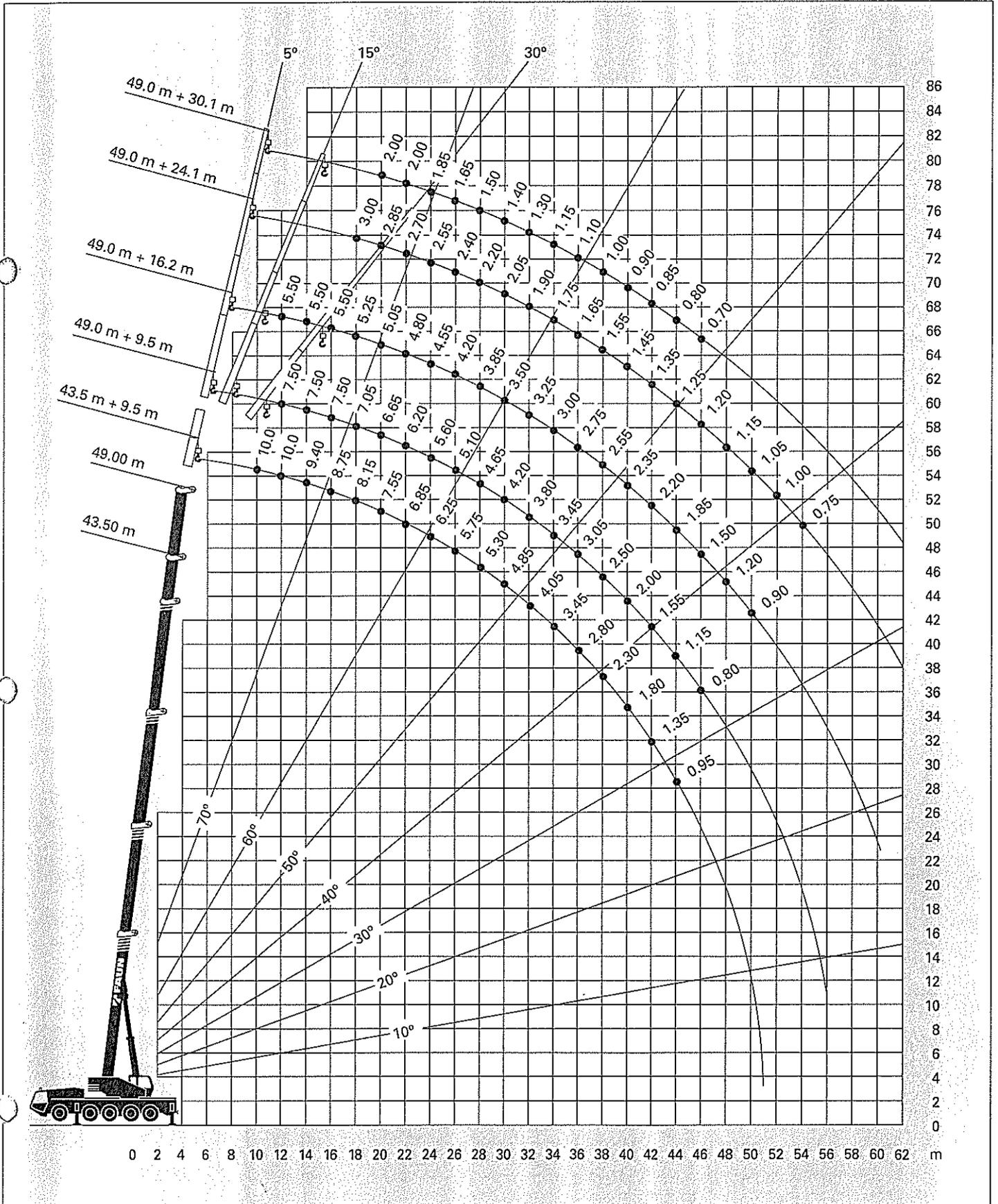
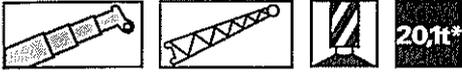

Tragfähigkeiten an der Spitze*

Lifting capacities on boom extension*

Capacités de levage à la rallonge de flèche*

Capacidades de elevación con plumín*

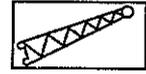
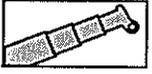

DIN

→m	43.5 m + 9.5 m			49.0 m + 9.5 m			49.0 m + 16.2 m			49.0 m + 24.1 m			49.0 m + 30.1 m			
	5°	15°	30°	5°	15°	30°	5°	15°	30°	5°	15°	30°	5°	15°	30°	
10.0	10.00			7.50												
11.0	10.00			7.50												
12.0	10.00	7.20		7.50	6.50		5.50									
14.0	9.40	7.20	5.20	7.50	6.50	5.00	5.50	4.20								
16.0	8.75	6.95	5.20	7.50	6.50	5.00	5.50	4.20	3.20							
18.0	8.15	6.70	5.05	7.05	6.20	5.00	5.25	4.20	3.10	3.00						
20.0	7.55	6.45	4.95	6.65	5.95	4.90	5.05	4.05	3.00	2.85	2.45					
22.0	6.40	6.05	4.80	6.20	5.65	4.75	4.80	3.85	2.95	2.70	2.30					
24.0	5.10	5.40	4.60	5.35	5.40	4.65	4.55	3.70	2.85	2.55	2.15	1.70	1.85	1.55		
26.0	4.00	4.35	4.40	4.25	4.60	4.50	4.20	3.50	2.75	2.40	2.00	1.60	1.65	1.40		
28.0	3.15	3.40	3.75	3.35	3.65	4.00	3.85	3.35	2.70	2.20	1.85	1.55	1.50	1.30		
30.0	2.40	2.65	2.90	2.65	2.90	3.20	3.45	3.15	2.60	2.05	1.75	1.45	1.40	1.25	1.05	
32.0	1.75	1.95	2.20	2.00	2.20	2.50	2.75	3.00	2.50	1.90	1.65	1.40	1.30	1.15	1.00	
34.0	1.20	1.40	1.60	1.40	1.65	1.85	2.20	2.50	2.40	1.75	1.55	1.30	1.15	1.05	0.95	
36.0	0.70	0.85	1.05	0.90	1.10	1.30	1.65	1.95	2.35	1.65	1.45	1.25	1.10	1.00	0.90	
38.0						0.85	1.20	1.50	1.85	1.55	1.35	1.20	1.00	0.90	0.85	
40.0							0.80	1.05	1.35	1.25	1.30	1.15	0.90	0.85	0.80	
42.0								0.70	0.95	0.90	1.25	1.10	0.85	0.80	0.75	
44.0											0.90	1.05	0.80	0.75	0.70	
46.0												1.00		0.70		
48.0																
50.0																
52.0																
54.0																
56.0																
58.0																
60.0																
%	I	100			100			100			100			100		
	II	100			100			100			100			100		
	III	70			100			100			100			100		
	IV	70			100			100			100			100		

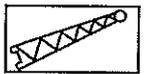
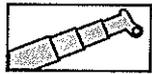

85%

→m	43.5 m + 9.5 m			49.0 m + 9.5 m			49.0 m + 16.2 m			49.0 m + 24.1 m			49.0 m + 30.1 m			
	5°	15°	30°	5°	15°	30°	5°	15°	30°	5°	15°	30°	5°	15°	30°	
10.0	11.50			8.60												
11.0	11.50			8.60												
12.0	11.50	8.30		8.60	7.50		6.35									
14.0	10.60	8.30	6.00	8.60	7.50	5.75	6.35	4.85								
16.0	9.90	8.00	6.00	8.60	7.50	5.75	6.35	4.85	3.70							
18.0	9.30	7.70	5.80	8.10	7.15	5.75	6.05	4.85	3.55	3.45						
20.0	8.60	7.40	5.70	7.65	6.85	5.65	5.80	4.65	3.45	3.30	2.80					
22.0	7.35	6.95	5.50	7.15	6.50	5.45	5.50	4.45	3.40	3.10	2.65					
24.0	5.90	6.25	5.30	6.15	6.20	5.35	5.25	4.25	3.30	2.95	2.45	1.95	2.15	1.80		
26.0	4.60	5.00	5.05	4.90	5.30	5.20	4.85	4.05	3.15	2.75	2.30	1.85	1.90	1.60		
28.0	3.60	3.90	4.30	3.85	4.20	4.60	4.45	3.85	3.10	2.55	2.15	1.80	1.75	1.50		
30.0	2.75	3.05	3.35	3.05	3.35	3.70	3.95	3.65	3.00	2.35	2.00	1.65	1.60	1.45	1.20	
32.0	2.00	2.25	2.55	2.30	2.55	2.90	3.15	3.45	2.90	2.20	1.90	1.60	1.50	1.35	1.15	
34.0	1.40	1.60	1.85	1.60	1.90	2.15	2.55	2.90	2.75	2.00	1.80	1.50	1.30	1.20	1.10	
36.0	0.85	1.00	1.20	1.05	1.25	1.50	1.90	2.25	2.70	1.90	1.70	1.45	1.25	1.15	1.05	
38.0						1.00	1.40	1.75	2.15	1.80	1.55	1.40	1.15	1.05	1.00	
40.0							0.95	1.20	1.55	1.45	1.50	1.35	1.05	1.00	0.95	
42.0								0.80	1.10	1.05	1.45	1.30	1.00	0.95	0.90	
44.0											1.05	1.20	0.90	0.85	0.80	
46.0												1.15		0.80		
48.0																
50.0																
52.0																
54.0																
56.0																
58.0																
60.0																
%	I	100			100			100			100			100		
	II	100			100			100			100			100		
	III	70			100			100			100			100		
	IV	70			100			100			100			100		

Hubhöhen
Lifting heights
Hauteurs de levage
Alturas de elevación

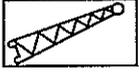
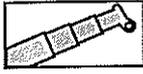

9,1t*

DIN

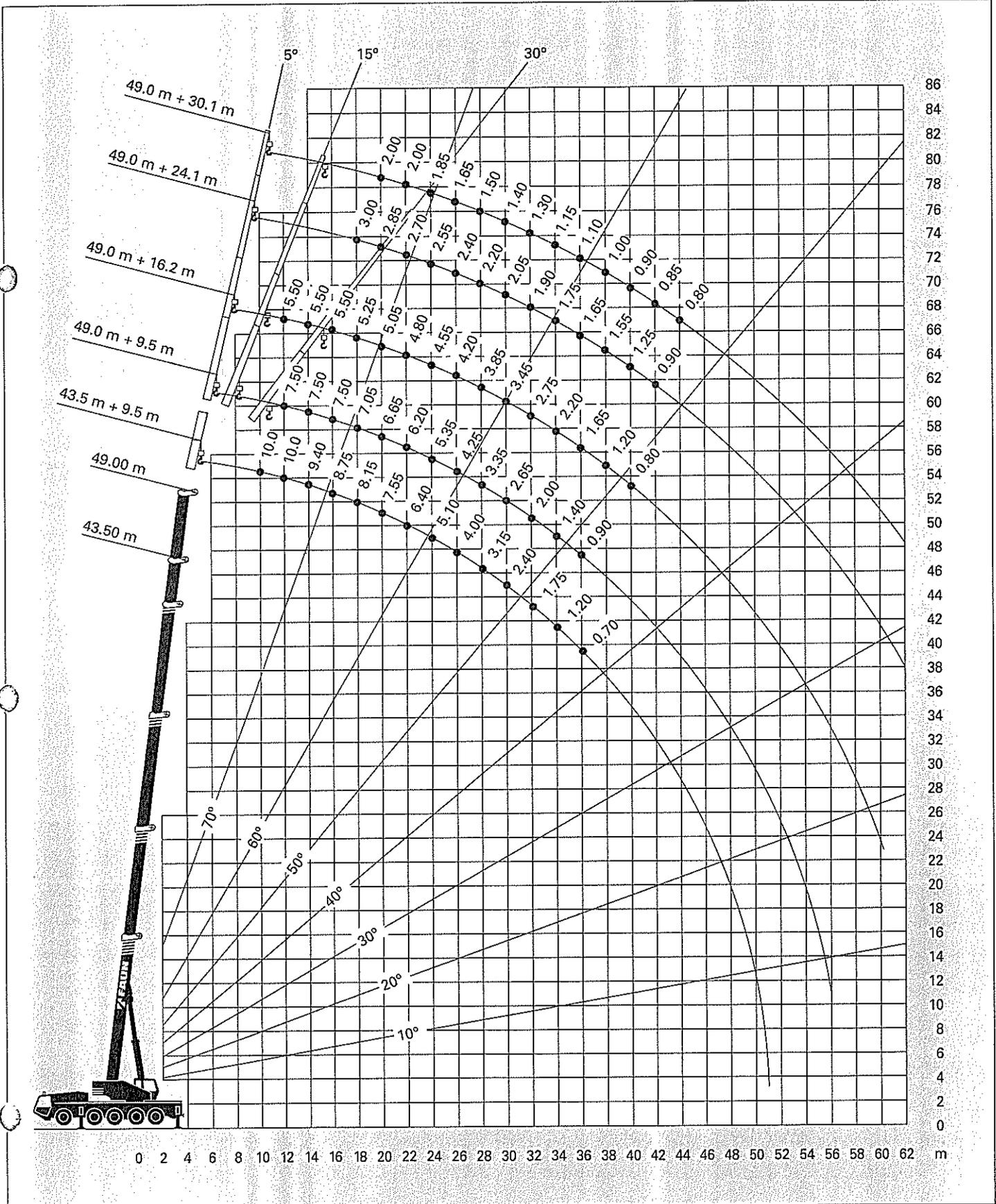

*) Gegen Mehrpreis

*) Against extra charge

*) Contre supplément de prix

*) Con suplemento de precio

Tragfähigkeiten an der Spitze*

Lifting capacities on boom extension*

Capacités de levage à la rallonge de flèche*

Capacidades de elevación con plumín*

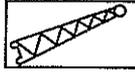
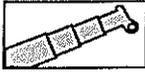

DIN

→m	43.5 m + 9.5 m			49.0 m + 9.5 m			49.0 m + 16.2 m			49.0 m + 24.1 m			49.0 m + 30.1 m			
	5°	15°	30°	5°	15°	30°	5°	15°	30°	5°	15°	30°	5°	15°	30°	
10.0	10.00			7.50												
11.0	10.00			7.50												
12.0	10.00	7.20		7.50	6.50		5.50									
14.0	9.40	7.20	5.20	7.50	6.50	5.00	5.50	4.20								
16.0	8.75	6.95	5.20	7.50	6.50	5.00	5.50	4.20	3.20							
18.0	7.70	6.70	5.05	7.05	6.20	5.00	5.25	4.20	3.10	3.00						
20.0	5.90	6.30	4.95	6.15	5.95	4.90	5.05	4.05	3.00	2.85	2.45		2.00			
22.0	4.50	4.75	4.80	4.70	5.05	4.75	4.80	3.85	2.95	2.70	2.30		2.00			
24.0	3.45	3.70	4.10	3.60	4.00	4.40	4.40	3.70	2.85	2.55	2.15	1.70	1.85	1.55		
26.0	2.50	2.75	3.10	2.70	3.00	3.40	3.50	3.50	2.75	2.40	2.00	1.60	1.65	1.40		
28.0	1.75	2.00	2.30	1.95	2.25	2.55	2.75	3.20	2.70	2.20	1.85	1.55	1.50	1.30		
30.0	1.05	1.30	1.60	1.30	1.50	1.85	2.10	2.45	2.60	2.05	1.75	1.45	1.40	1.25	1.05	
32.0		0.70	0.95	0.70	0.90	1.20	1.50	1.85	2.35	1.90	1.65	1.40	1.30	1.15	1.00	
34.0						0.70	1.00	1.30	1.75	1.50	1.55	1.30	1.15	1.05	0.95	
36.0								0.85	1.25	1.00	1.45	1.25	1.10	1.00	0.90	
38.0									0.80		1.05	1.20	0.85	0.90	0.85	
40.0											0.70	1.15	0.85	0.85	0.80	
42.0												0.80	0.85	0.85	0.75	
44.0													0.70	0.70	0.70	
46.0																
48.0																
50.0																
52.0																
54.0																
56.0																
58.0																
60.0																
%	I	100			100			100			100			100		
	II	100			100			100			100			100		
	III	70			100			100			100			100		
	IV	70			100			100			100			100		

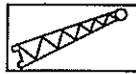
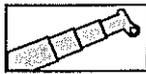

85%

→m	43.5 m + 9.5 m			49.0 m + 9.5 m			49.0 m + 16.2 m			49.0 m + 24.1 m			49.0 m + 30.1 m			
	5°	15°	30°	5°	15°	30°	5°	15°	30°	5°	15°	30°	5°	15°	30°	
10.0	11.50			8.60												
11.0	11.50			8.60												
12.0	11.50	8.30		8.60	7.50		6.35									
14.0	10.60	8.30	6.00	8.60	7.50	5.75	6.35	4.85								
16.0	9.90	8.00	6.00	8.60	7.50	5.75	6.35	4.85	3.70							
18.0	8.80	7.70	5.80	8.10	7.15	5.75	6.05	4.85	3.55	3.45						
20.0	6.80	7.25	5.70	7.10	6.85	5.65	5.80	4.65	3.45	3.30	2.80		2.30			
22.0	5.20	5.50	5.50	5.40	5.80	5.45	5.50	4.45	3.40	3.10	2.65		2.30			
24.0	3.95	4.25	4.75	4.15	4.60	5.05	5.05	4.25	3.30	2.95	2.45	1.95	2.15	1.80		
26.0	2.90	3.15	3.55	3.10	3.45	3.90	4.05	4.05	3.15	2.75	2.30	1.85	1.90	1.60		
28.0	2.00	2.30	2.65	2.25	2.60	2.95	3.15	3.70	3.10	2.55	2.15	1.80	1.75	1.50		
30.0	1.20	1.50	1.85	1.50	1.75	2.15	2.40	2.80	3.00	2.35	2.00	1.65	1.60	1.45	1.20	
32.0		0.80	1.10	0.80	1.05	1.40	1.75	2.15	2.70	2.20	1.90	1.60	1.50	1.35	1.15	
34.0						0.80	1.15	1.50	2.00	1.75	1.80	1.50	1.30	1.20	1.10	
36.0								1.00	1.45	1.15	1.70	1.45	1.25	1.15	1.05	
38.0									0.95		1.20	1.40	1.00	1.05	1.00	
40.0											0.80	1.35	1.00	1.00	0.95	
42.0												0.95	0.80	0.80	0.90	
44.0														0.80	0.80	
46.0																
48.0																
50.0																
52.0																
54.0																
56.0																
58.0																
60.0																
%	I	100			100			100			100			100		
	II	100			100			100			100			100		
	III	70			100			100			100			100		
	IV	70			100			100			100			100		

Hubhöhen
Lifting heights
Hauteurs de levage
Alturas de elevación

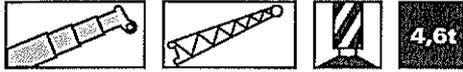

DIN

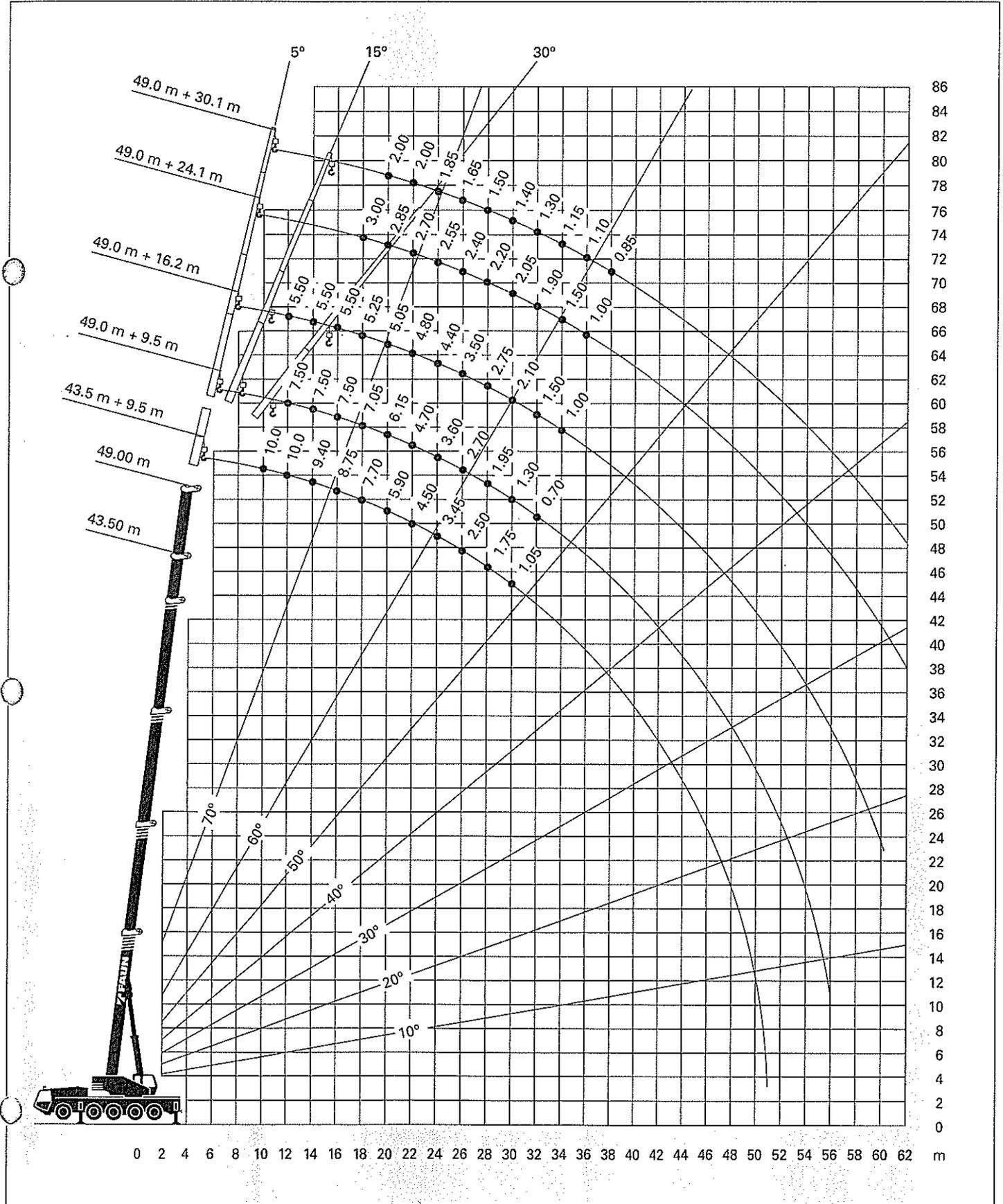

*) Gegen Mehrreiss

*) Against extra charge

*) Contre surélément de prix

*) Con sulemento de precio *Courtesy of CraneMarket*



Rahmen Verwindungs- und biegesteife Schweißkonstruktion aus hochfestem Feinkorn-Baustahl in Kastenbauweise.

Abstützung 4-Punkt-Doppelteleskopabstützungen mit hydraulisch ausschiebbaren Stützträgern. Bedienungsmöglichkeiten an beiden Seiten des Fahrgestelles. Stützbasis 8.00 m und 5.40 m.

Motor (EURO 1) Mercedes Benz 8-Zylinder-Dieselmotor OM 442 LA, wassergekühlt. Leistung 370 kW (503 PS) bei 2100 U/min. Drehmoment 2020 Nm (206 kpm) bei 1100 – 1600 U/min.

Getriebe ZF-Schaltgetriebe 16 S 220 A mit hydrodynamischem Drehmomentwandler und mit „lock-up“ Kupplung, 16 Vorwärts- und 2 Rückwärtsgängen.

Antrieb

10 x 6 für Straßenfahrt.
10 x 8 für Geländefahrt.

Achsen

1. Achse: gelenkt, nicht angetrieben.
2. Achse: Außenplanetenachse, gelenkt, angetrieben.
3. Achse: Außenplanetenachse, gelenkt, angetrieben mit integriertem Verteilergetriebe.
4. + 5. Achse: Außenplanetenachse, gelenkt, angetrieben. Quersperren in allen Antriebsachsen.

Achsaufhängung Hydropneumatische Federung mit Niveauregulierung.

Bremsen Druckluft-Zweikreis-Bremsanlage. Feststellbremse als Federspeicherbremse an der 3., 4. und 5. Achse wirkend. Retarder.

Räder 10-fach 16.00 R 25 Straßen- und Geländeprofil.

Lenkung ZF-Halbblock-Zweikreis-Hydraulenlenkung, mechanische Lenkung der 1., 2. + 3. Achse, hydraulisch unterstützt und mit Notlenkpumpe.

Fahrerhaus Zweimann-Frontfahrerhaus in Stahl-Kunststoff-Verbundkonstruktion, Sicherheitsverglasung, gefederter Fahrersitz und Beifahrersitz. Motorabhängige Warmwasserheizung, Kontroll- und Bedienungselemente für den Fahrbetrieb.

Elektrische Anlage 24 Volt Gleichstrom, 2 Batterien, nach der EG-Regulation.

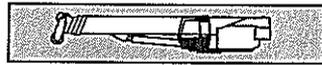

Rahmen Verwindungssteife Schweißkonstruktion mit einer dreireihigen Rollendrehverbindung, um 360° unbegrenzt drehbar.

Motor (EURO 1) Mercedes-Benz 6-Zylinder-Dieselmotor OM 366 A mit 112 kW (153 PS) bei 2000 U/min., wassergekühlt. Leistung nach DIN 6270 B.

Hydraulik System Diesel-hydraulisch mit 3-Kreis-hydraulik, 1 leistungsgeregelte Axialkolbendoppelpumpe (hydraulisch verstellbar, Cross-sensing), 1 Doppelpumpe.

Steuerventile Zwei 4-fach Kreuzsteuerhebel mit hydraulischer Vorsteuerung.

Teleskopausleger Fünfteiliger, kastenförmiger Teleskopausleger aus hochfestem Feinkornstahl, bestehend aus einem Grundausleger und 4 Teleskopteilen, unter Teillast teleskopierbar. 12.5 – 49.0 m lang.

Auslegerverlängerung* Teleskop-Spitzenausleger, seitlich klappbar 9.5 / 16.2 m lang, unter 5°/15°/30° abwinkelbar. Zusätzliche Stinger 7.5 m für 24.1 m Spitzenauslegerlänge und Zwischenstück 6.0 m für 30.1 m Spitzenauslegerlänge.

Wippwerk 1 Differentialzylinder mit angebautem Senkbremsventil.

Hubwerk Axialkolben-Konstant-Motor, Hubwerkstrommel mit eingebautem Planetengetriebe und federbelasteter Hydro-Lamellenbremse mit integriertem Freilauf beim Heben.

Drehwerk Konstant-Motor, dreistufiges Planetengetriebe mit fußbetätigter Betriebsbremse und Feststellung. Drehgeschwindigkeit stufenlos von 0 – 1.5 U/min.

Gegengewicht Gesamtgewicht 29.4 t teilbar.

Krankkabine Großräumige Krankkabine in Stahlblech-ausführung, großflächige Sicherheitsverglasung mit getönten Scheiben, verstellbarem hydraulisch gedämpften Fahrersitz. Motorunabhängige Warmluft-heizung. Kontroll- und Bedienungselemente für den Kranbetrieb.

Elektrische Anlage 24 Volt Gleichstrom, 2 Batterien.

Sicherheitseinrichtung Elektronische Lastmomentbegrenzung (LMB), Sicherheitsventile gegen Rohr- und Schlauchbrüche, Windenendschalter, Seilwindendrehmelder, Hubendschalter und Windmesser.

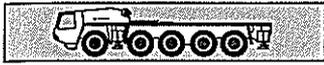

Frame Box-type, torsion resistant, welded construction made of high tensile steel with integral outrigger housings.

Outriggers Four point, fully hydraulic, double telescopic. Controls on both sides of carrier with level gauges. Outrigger spread 8.00 m and 5.40 m.

Carrier Engine (EURO 1) Mercedes Benz 8 cylinder, diesel, water-cooled engine, model OM 442 LA. Rating 370 kW (503 HP) at 2100 rpm. Torque 2020 Nm (206 kpm) at 1100- 1600 rpm.

Transmission ZF-transmission 16 S 220 A and hydro-dynamic torque converter with "lock-up", 16 forward and 2 reverse gears.

Drive 10 x 6 on-road.
10 x 8 off-road.

Axles

1st axle: steered, not driven.
2nd axle: with outer planetary hubs, steered, driven.
3rd axle: with outer planetary hubs, driven, steered, with integrated transfer gear.
4th + 5th axle: with outer planetary hubs, driven, steered. Transverse differential lock in all drive-axes.

Suspension Hydro-pneumatic with levelling adjustment.

Brake system Service brake: dual circuit compressed air system.

Parking brake: spring loaded type acting on 3rd, 4th and 5th axles.

Retarder in transmission.

Wheels (10) 16.00 R 25 on/off road profile tyres.

Steering system ZF dual circuit semi-block, mechanical steering of front three axles with hydraulic booster and transmission-mounted emergency pump.

Carrier cab Two man full width cab of composite (steel sheet metal and fibre-glass) structure, with safety glass, cushioned adjustable seats, motor dependent warm-water heater. Complete controls and instrumentation for road travel.

Electrical system 24 volt DC system with 2 batteries. Lighting according to EEC regulations.

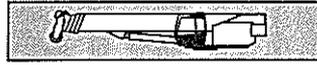

Frame Torsion-resistant all-welded structure of high strength steel. Connected to carrier by triple roller bearing slewing ring for 360° continuous rotation.

Crane engine (EURO 1) Mercedes Benz 6 cylinder, diesel, water cooled engine, model OM 366 A rated at 112 kW (153 HP) at 2000 rpm (according to DIN 6270 B).

Hydraulic system Three circuit diesel hydraulic system with 1 double axial piston variable displacement pump (hydraulically adjustable with cross-sensing) and 1 double pump.

Hydraulic controls 2 joy-stick levers for simultaneous crane motions, hydraulically controlled.

Telescopic main boom Five section box type construction of high tensile, fine-grained steel consisting of 1 base section and 4 telescopic sections. All sections hydraulically extendable under load. 12.5 – 49.0 m long.

Boom extension* Swing-around, telescopic lattice boom extension 9.5 – 16.2 m, offsets 5°/15°/30° plus stinger 7.5 m giving length of 24.1 m plus 6 m insert giving a total maximum length of 30.1 m.

Boom hoist 1 double acting hydraulic cylinder with integral holding valve.

Main winch Axial piston constant displacement motor, hoist drum with planetary reduction and spring-loaded, multiple disc brake.

Slewing gear Constant displacement motor with three-stage planetary gear with a foot actuated service brake and a parking brake.
Slewing infinitely variable: 0 – 1.5 rpm.

Counterweight Total 29.4 t divisible.

Crane cab Spacious all-steel comfortable panoramic cab with special tinted safety glass, hydraulically cushioned and adjustable seat, independent hot-air heater. Controls and instrumentation for crane operation.

Electrical system 24 volt DC system with 2 batteries.

Safety devices Load moment device (LMD). Safety valves against pipe and hose rupture, holding valves on hydraulic cylinders, lower limit switch on main winch drum, drum turn indicator, hoist limit switch and anemometer.





Châssis Construction mécano-soudée, en forme de caisson, résistante aux flexions et aux torsions.

Calage 4 poutres extensibles hydrauliquement du côté gauche et droite du châssis. Largeur de calage 8.00 m et 5.40 m.

Moteur (EURO 1) Mercedes-Benz diesel OM 442 LA-370 kW (503 CV à 2100 tr/min) refroidi par eau. Couple-moteur: 2020 Nm (206 Kpm) de 1100 à 1600 tr/min.

Boîte de vitesses Boîte powershift ZF 16 S 220 A avec convertisseur de couple et rapport tout terrain (type Crawler). Convertisseur avec embrayage lock-up avec 16 vitesses AV et 2 AR.

Entraînement

10 x 6 sur la route
10 x 8 en tout terrain.

Ponts

1^{er} essieu: directeur, non-entraîné.
2^{ème} essieu: moto-directeur avec réduction planétaire dans les moyeux.
3^{ème} essieu: moto-directeur avec réduction planétaire dans les moyeux et boîte de transfert intégrée.
4^{ème} + 5^{ème} essieu: moto-directeur avec réduction planétaire dans les moyeux et différentiels interponts (2 à 5).

Suspension

Hydropneumatique-réglage d'inclinaison à suspension bloquée.

Freins

Frein de service: système de frein à air comprimé à double circuit.

Frein de parcage: Frein à ressorts accumulateurs agissant sur le 3^e, 4^e et 5^e essieu.

Ralentisseur dans la boîte.

Pneumatiques 10 pneus 16.00 R 25

Direction Direction hydraulique ZF semi-bloc à 2 circuits. Commande mécanique des essieux 1+2+3, assistée hydrauliquement et avec pompe de direction auxiliaire.

Cabine du conducteur Cabine bi-place, construction en matière combinée, avec vitrage en verre de sécurité, siège de conducteur à ressort et amorti hydrauliquement.

Installation électrique 24 V courant continu, 2 batteries, conforme au code de la route de la C.E.E.

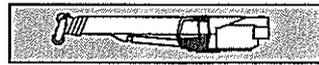

Plate forme Construction mécano-soudée de conception spécifique FAUN, résistant à la torsion. Couronne d'orientation sur galets à trois rangées, permettant une rotation illimitée à 360°.

Moteur (EURO 1) Moteur Diesel DB, type OM 366 A avec 6 cylindres et une puissance de 112 kW (153 CV), à 2000 tr/min. Puissance selon DIN 6270 B.

Système hydraulique Diesel-hydraulique, avec 3 circuits, comprenant 1 double pompe à pistons axiaux à régulation de puissance (réglable hydrauliquement, système cross-sensing) et 1 double pompe.

Commandes 2 manipulateurs à commande en croix, assistés hydrauliquement.

Mécanisme de relevage 1 vérin différentiel muni d'un limiteur de vitesse en descente.

Orientation Moteur hydraulique avec entraînement planétaire à 3 gammes. Frein de service actionné par l'intermédiaire d'une pédale et frein de stationnement. Vitesse de rotation 0 à 1.5 tr/min.

Mécanisme de levage Moteur hydraulique, tambour de levage avec boîte planétaire incorporée, frein d'arrêt à disques multiples à ressort, libéré lors du levage.

Télescopage 1 élément de base et 4 éléments télescopiques, télescopables hydrauliquement sous charge. Longueur de flèche: 12.5 m à 49.0 m.

Rallonge de flèche* Construction en treillis de 9.5 m à 16.2 m, rabattable latéralement et inclinable à 5° / 15° / 30°. Rallonge mécanique suppl. de 7.5 m montée sur fléchette pour porter à 24.1 m et possibilité d'intercaler une pièce intermédiaire en treillis de 6.0 m pour une hauteur totale de 30.1 m.

Contrepoids Poids total 29.4 tonnes. Poids divisible.

Cabine En acier avec vitrage de sécurité, siège suspendu sur ressorts, amorti hydrauliquement et réglable. Chauffage à air chaud indépendant du moteur. Tableau de bord avec instruments de contrôle.

Équipement électrique 24 V courant continu, 2 batteries.

Dispositifs de sécurité Contrôleur électronique de charge (CEC), clapets anti-retour contre rupture des conduites et flexibles, fin de course du treuil pour câble de levage, indicateur du nombre de tours sur tambour de treuil, interrupteur fin de course de levage et anémomètre.

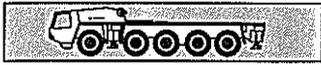

Chasis Construcción de tipo de caja de acero de alta resistencia soldado, resistente a la torsión, con alojamientos integrales para los estabilizadores.

Estabilizadores Telescópicos dobles, totalmente hidráulicos de cuatro puntos. Controlados desde ambos lados del chasis portante con manómetros de nivel. Extensión de los estabilizadores: 8.00 m y 5.40 m.

Motor del chasis portante Mercedes Benz (EURO 1) modelo OM 442 LA, 8 cilindros, diesel, refrigerado por agua. Nominal 370 kW (503 HP) a 2100 rpm. Par 2020 Nm (206 kpm) a 1100 - 1600 rpm.

Transmisión Transmisión powershift ZF 16 S 220 A convertidor de par hidro-dinámico con bloqueo, 16 velocidades de avance y 2 velocidades de marcha atrás.

Tracción

10 x 6 en carretera.
10 x 8 fuera de carretera.

Ejes

1^{er} eje: de dirección, no accionado.
2^o eje: con cubos planetarios externos, de dirección, accionado.
3^{er} eje: con cubos planetarios externos, accionado, de dirección, con engranaje transfer integrado.
4^o y 5^o ejes: con cubos planetarios externos, accionado, de dirección.
Con bloqueo diferencial transversal en todos los ejes accionados.

Suspension Hidroneumática con ajuste de nivelación.

Sistema de frenos Freno de servicio: sistema de aire comprimido de doble circuito.

Freno de estacionamiento: de tipo cargado por resortes, actuando sobre los ejes 3^o, 4^o y 5^o.
Retardador en la transmisión.

Neumáticos (10) neumáticos 16.00 R 25 con dibujo para carretera y fuera de ella.

Sistema de dirección Dirección mecánica con semibloqueo de doble circuito ZF de tres ejes delanteros con reforzador hidráulico y bomba de emergencia montada en la transmisión.

Cabina del chasis portante Cabina de anchura total para dos hombres, de estructura compuesta (chapa de acero y fibra de vidrio), con lunas de seguridad, sillones amortiguados regulables, calentador de agua caliente dependiente del motor. Controles completos e instrumentos para circulación por carretera.

Sistema eléctrico Sistema a 24 V c.c. con 2 baterías. Alimentación de acuerdo con las normas CEE.

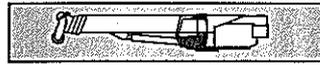

Superestructura Estructura de acero de alta resistencia, toda soldada, resistente a la torsión. Conectada al chasis mediante la corona de giro de triple fila de rodillos para rotación continua de 360°.

Motor de la grúa Motor Mercedes Benz (EURO 1) modelo OM 366 A, 6 cilindros, diesel, refrigerado por agua, nominal 112 kW (153 HP) a 2000 rpm (de acuerdo con normas DIN 6270 B).

Sistema hidráulico Sistema hidráulico diesel de tres circuitos con una bomba doble de pistones axiales de caudal variable (hidráulicamente regulable con sensor cruzado) y una bomba doble.

Controles hidráulicos 2 palancas de control infinito de tipo universal (joy-stick) para movimientos simultáneos de la grúa con control hidráulico.

Pluma principal telescópica Construcción de tipo de caja, de acero de grano fino de alta resistencia, con cinco tramos, un tramo de base y cuatro tramos telescópicos. Todos los tramos se extienden hidráulicamente bajo carga, longitud de 12.5 m a 49.0 m.

Prolongación de la pluma* Prolongación de la pluma de celosía telescópica, de 9.5 - 16.2 m de longitud, angulable a 5° / 15° / 30° más un plumín de alcance de 7.5 m dando una longitud de 24.1 m más una pieza intermedia de celosía de 6 m para una longitud total máxima de 30.1 m.

Elevación de la pluma Un cilindro hidráulico de doble efecto con válvula de retención integrada.

Cabrestante principal Motor de pistones axiales de desplazamiento constante, tambor de elevación con reducción planetaria y freno multidisco cargado por resortes.

Sistema de giro Motor de desplazamiento constante con engranaje planetario de tres etapas, con freno de servicio controlado con el pie y freno de estacionamiento. Velocidad de giro infinitamente variable: 0 - 1.5 rpm.

Contrapeso Total de 29.4 ton divisible.

Cabina de la grúa Cabina panorámica, espaciosa y confortable, toda de acero, con lunas de seguridad tintadas especiales con sillón regulable amortiguado hidráulicamente y calentador por aire caliente independiente completa con controles e instrumentos para la operación de la grúa.

Sistema eléctrico Sistema a 24 V c.c. con 2 baterías.

Dispositivos de seguridad Dispositivo de momento de carga (LMD). Válvulas de seguridad contra rotura de tuberías y latiguillos, válvulas de retención en los cilindros hidráulicos, interruptor de límite de bajada en el cabrestante principal, indicador de vueltas del tambor, interruptor final de elevación y anemómetro.

Anmerkungen zu den Traglasttabellen

Die Tragfähigkeiten im Festigkeitsbereich basieren auf DIN 15018 Blatt 2 und Blatt 3 und F.E.M.

Die Tragfähigkeiten im Standsicherheitsbereich entsprechen DIN 15019 Teil 2.

Die 85% Tragfähigkeitsangaben überschreiten nicht 85% der Kipplast. Dynamische Einflüsse und Wind reduzieren die Tragfähigkeiten. Die 85% Tragfähigkeitsangaben entsprechen nicht den Sicherheitsanforderungen der EG-Maschinen-Richtlinie.

Die zulässige Windgeschwindigkeit beträgt maximal 10 m/sec.

Die Tragfähigkeiten sind in metrischen Tonnen angegeben.

Das Gewicht des Lasthakens bzw. der Hakenflasche und weiterer Anschlagmittel ist von der Tragfähigkeit abzuziehen.

Die Tragfähigkeiten für den Teleskopausleger gelten nur bei demontierter Spitze.

Die Ausladung ist der horizontale Abstand von Mitte Drehkranz bis Mitte freihängender, nicht schwingender Last.

Tragfähigkeitsänderungen vorbehalten.

Obige Angaben dienen nur zur Information. Die Bedienungsanleitungen müssen zu Rate gezogen werden, bevor die Maschine in Betrieb genommen wird. Alle hier gemachten Angaben beziehen sich auf die Standard-Ausführung. Jegliche Ausrüstungsveränderungen können die angegebenen Werte beeinflussen.

Remarks concerning the load charts

The lifting capacities in the structural area are based on DIN 15018 parts 2 and 3 and F.E.M.

The lifting capacities in the stability area are based on DIN 15019 part 2.

The 85% lifting capacities do not exceed 85% of tipping load. Dynamic influences and wind reduce the lifting capacities. The 85% lifting capacities do not comply with the safety requirements of the EEC Machinery Directive.

The maximum permissible wind speed for crane operation is 10 m/min.

The lifting capacities shown are in metric tons.

The weight of load handling devices such as hook blocks, slings, etc., must be considered as part of the load and must be deducted from the lifting capacities.

The lifting capacities for the telescopic boom apply to a crane with no boom extensions being stowed or mounted on the crane.

The working radius is the horizontal distance from the centre of rotation to the centre of the freely suspended non-oscillating load.

The lifting capacities are subject to change without prior notice.

The above remarks are for basic information only and the operator's manual must be consulted before operating this crane. All data and performances refer to the standard crane. The addition of optional and other equipment may affect the performance of the crane.

Remarques relatives aux tableaux des charges

Les forces de levage sont conformes aux normes DIN 15018, p. 2 et 3, et F.E.M.

Les forces de levage dans la partie de stabilité au renversement sont conformes aux normes DIN 15019, chap. 2.

Les charges de levage indiquées de 85% ne dépassent pas 85% de la charge de renversement. Les influences dynamiques et le vent réduisent les charges de levage. Les charges de levage indiquées de 85% ne correspondent pas aux exigences de sécurité de la directive CE relative aux machines.

La grue peut travailler aux vitesses de vent allant jusqu'à 10 m/s.

Les forces de levage sont données en tonnes métriques.

Le poids du crochet-moufle et de tous les accessoires d'élingage font partie de la charge et sont à déduire des charges indiquées.

Les forces de levage indiquées pour la flèche télescopique s'entendent fléchette déposée.

Comme portée, on entend la distance horizontale du centre de la couronne de rotation au centre de la charge librement suspendue et non oscillante.

Sauf modification de forces de levage.

Les données ci-dessus servent à titre d'information. Avant la mise en marche de la grue il est conseillé d'étudier les instructions de service. Toutes les données indiquées ci-dessus se réfèrent à la machine de base. Tout changement de l'équipement de la grue peut influencer ces valeurs.

Notas relativas a los graficos de carga

En cuanto a los datos referentes a resistencia, las capacidades de carga están basados sobre las normas DIN 15018, pág. 2 y 3, y F.E.M.

En cuanto a los datos referentes a estabilidad anti-vuelco, las capacidades de carga están basados sobre las normas DIN 15019, Cap. 2.

Las indicaciones acerca de la capacidad de carga del 85% no superan el 85% de la carga de vuelco. Influencias dinámicas y del viento reducen las capacidades de carga. Las indicaciones acerca de la capacidad de carga del 85% no corresponden a las normas de seguridad según la directiva para máquinas de la CE.

La velocidad anemométrica max. admisible es de 10 m/seg.

Las capacidades de carga indicadas en las tablas corresponden a toneladas métricas.

Hay que deducir los pesos del gancho o del motón y de otros dispositivos para fijación de cargas de los valores de capacidad de carga indicados en las tablas.

Las capacidades de carga referentes a la pluma telescópica rigen solamente si la punta está desmontada.

Como alcance se entiende la distancia horizontal desde el centro de la corona de rodaduras hasta el centro de la carga suspendida libremente y no oscilante.

Salvo modificación de capacidades de carga.

Los datos arriba indicados sirven solamente para su información. Hay que leer las instrucciones para el uso antes de la puesta en servicio de la máquina. Todos los datos mencionados en las presentes tablas rigen para los modelos standard. Cualquier modificación del equipo montado puede dar lugar a modificaciones de aquellos valores.

Hakenhöhen/Kopfhöhen
 Hook height/Tip height
 Hauteurs sous crochet/Hauteurs tête de flèche
 Altura del gancho/Altura de la pluma

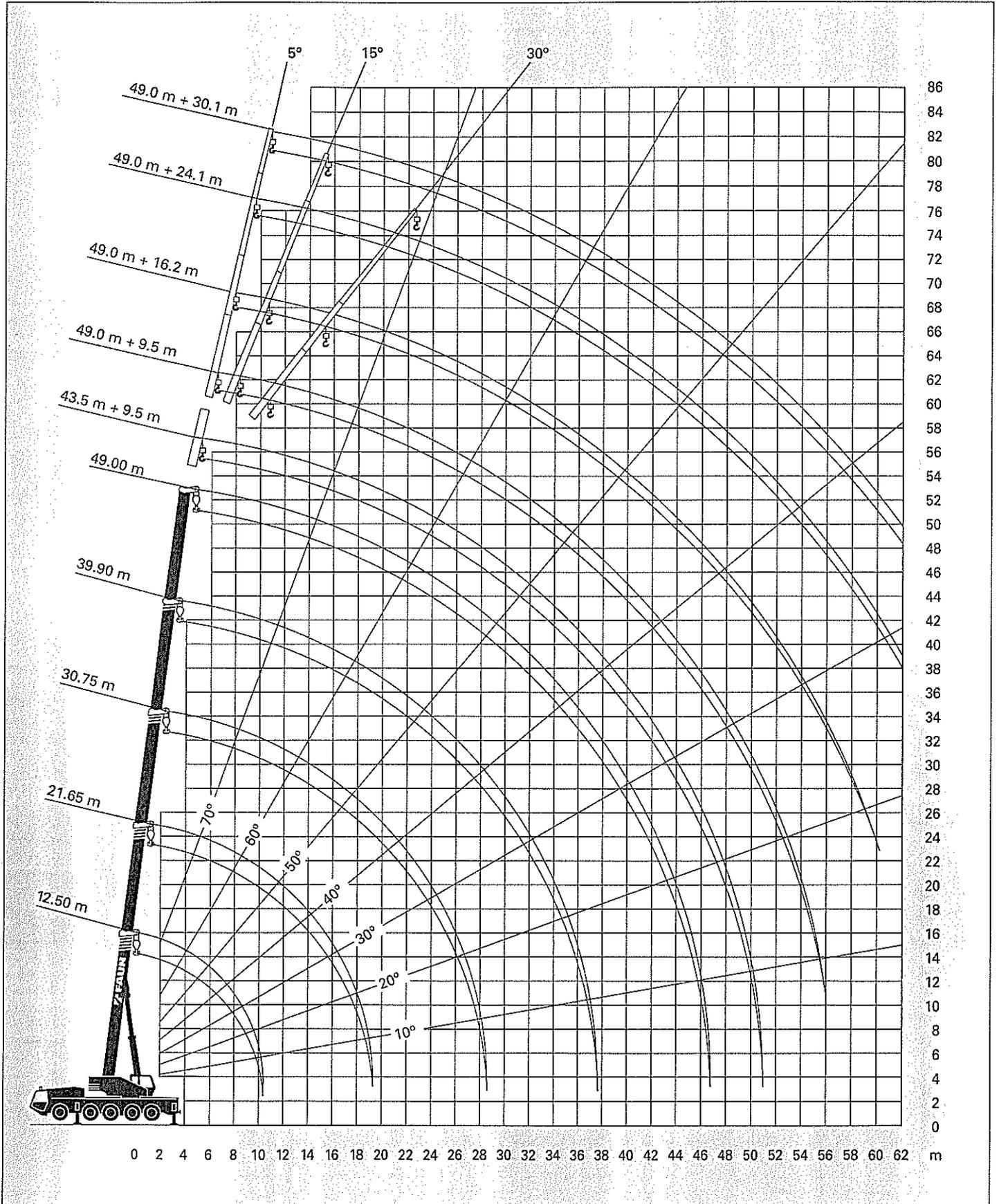

24

	D	→	00 49	
A	B	CH	DK	F
GB	I	N	NL	P
E	07	49	S	00 949

	(0) 91 23 95 50	
	(0) 17 18 11 43 24	
	(0) 91 23 18 51 55	
	(0) 91 23 18 52 19	
	(0) 91 23 30 85	
	http://www.tadanofaun.de	
	http://www.faun.de	
	e-mail: info@tadanofaun.de	
	SERVICE	 → 