







24

	SERVICE  → 
	(0) 91 23 95 50 
	(0) 17 18 11 43 24 
	(0) 91 23 18 51 55
	(0) 91 23 18 52 19
	(0) 91 23 30 85
	Service + Spare parts
	e-mail: service@tadanofaun.de
	e-mail: spareparts@tadanofaun.de
	 → ++49



HK 50

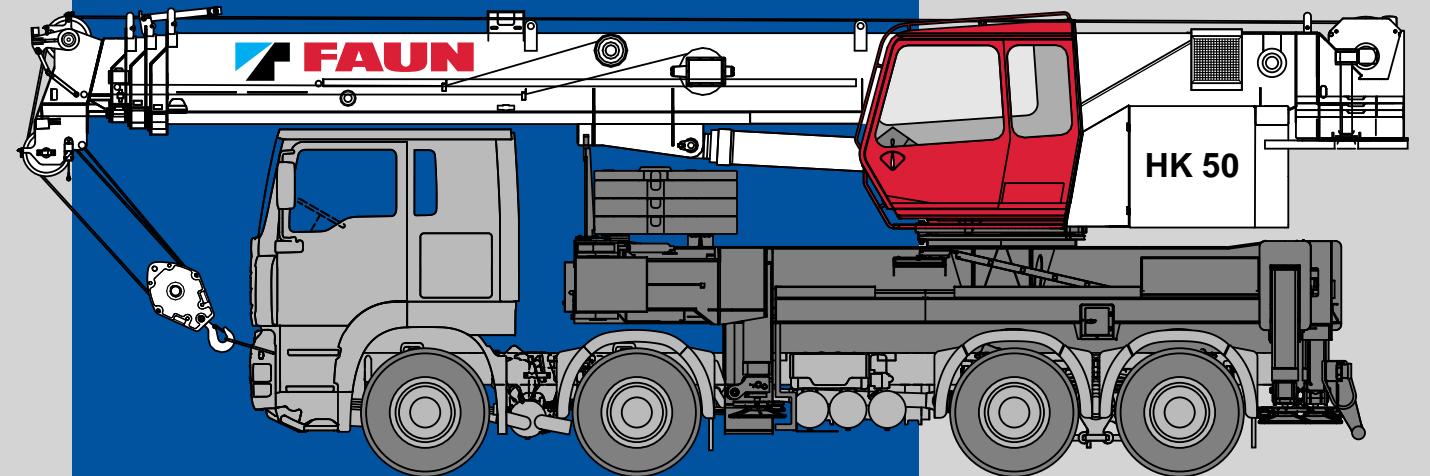

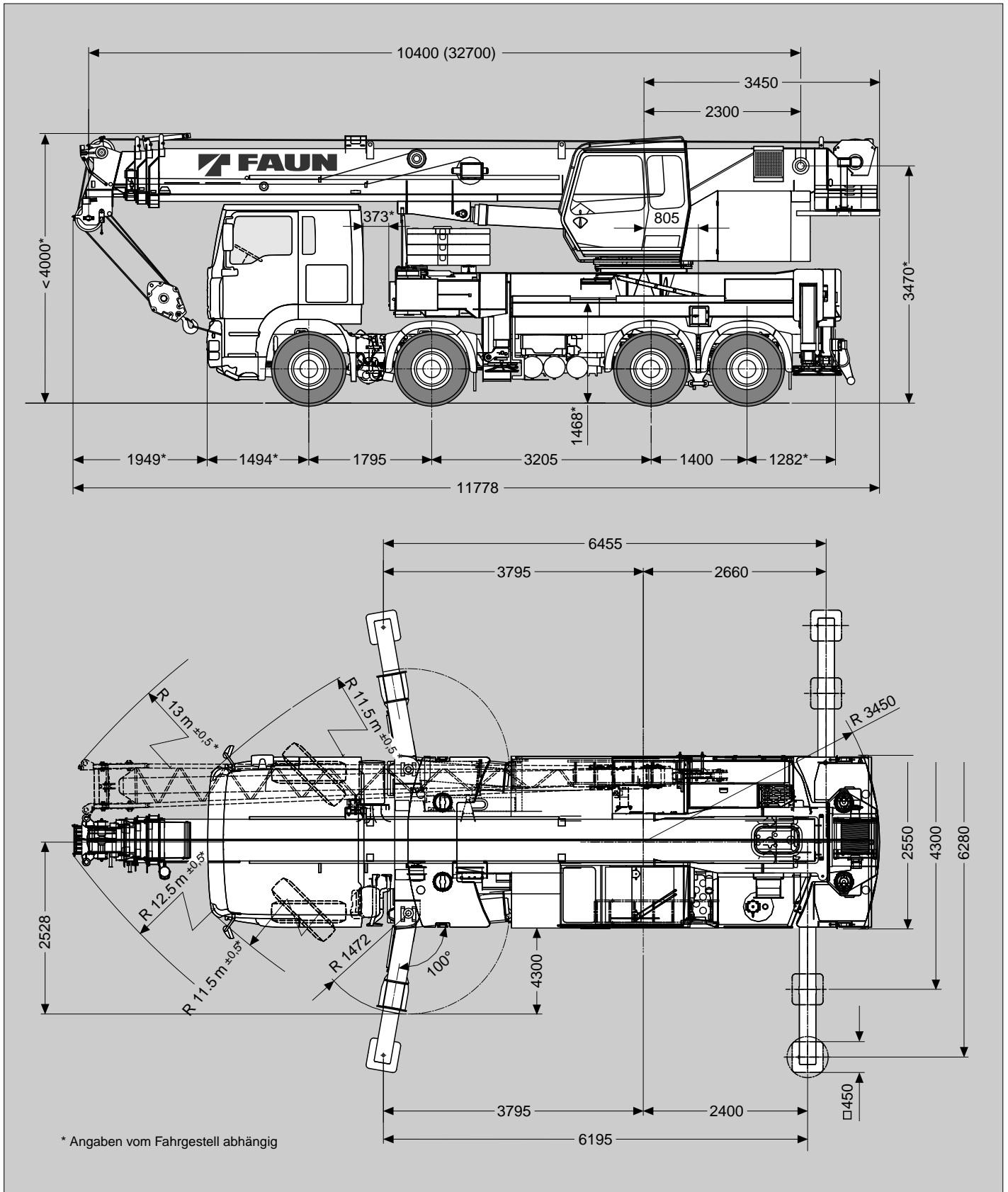
Maße / Dimensions (mm)
 Gewichte / Weights
 Geschwindigkeiten / Speeds



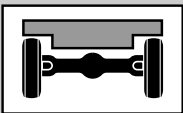



Gewichte / Geschwindigkeiten Weights / Working speeds

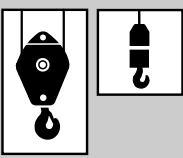



	Achse / Axle	1	2	3	4	Gesamtgewicht / Total weight
	4-  (t)	≤ 9*	≤ 9*	≤ 12*	≤ 12*	≤ 42*

* Abhängig vom Fahrgestell, incl. 8,8 t Gegengewicht, 9 m Auslegerverlängerung, 12,5 t Unterflasche, 6 t Hakengeschirr.
* Depending on chassis, incl. 8.8 t counterweight, 9 m boom extension, 12.5 t hook block, 6 t swivel hook.

	Traglast / Lifting capacity	Rollen / Sheaves	Stränge / Parts of line	Gewicht / Weight
	50 t	5	11	475 kg
	32 t	3	7	300 kg
	12.5 t	1	3	170 kg
	6 t	–	1	150 kg

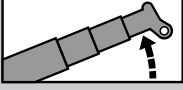
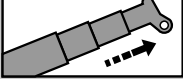

								
km/h 	Alle diese Daten abhängig vom Fahrgestell This data depending on chassis							
km/h 								
								

V+ 	Stufenlos Infinitely variable	Seil Rope	Max. Seilzug Max. single line pull
	0 - 130 m/min für einfachen Strang single line	16 mm / 170 m	52 kN 1. Lage 1st layer
	0 - 65 m/min für einfachen Strang single line	16 mm / 170 m	52 kN 1. Lage 1st layer
	0 - 2 min ⁻¹		
	-2° - +82° ca. 33 s approx. 33 s		
	10.4 m - 32.7 m ca. 90 s approx. 90 s		

Tragfähigkeiten am Teleskopausleger Lifting capacities on telescopic boom

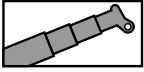

8.8 t

DIN/ISO

m	10.4 m	14.1 m	17.8 m	21.6 m	25.3 m	29.0 m	32.7 m
2.5	50.0						
3.0	44.7	30.0					
3.5	40.6	30.0	30.0				
4.0	37.2	30.0	30.0	20.0			
4.5	34.3	30.0	29.1	20.0	17.0		
5.0	31.7	30.0	26.8	20.0	17.0	16.0	
6.0	27.6	27.1	23.2	20.0	17.0	16.0	12.0
7.0	23.3	22.6	20.3	20.0	17.0	15.9	12.0
8.0	18.6	17.9	19.3	18.7	16.3	14.7	12.0
9.0		14.6	16.0	15.4	14.6	13.3	12.0
10.0		12.2	13.5	13.0	13.0	12.3	11.1
11.0		10.4	11.6	11.1	11.1	11.3	10.2
12.0			10.2	9.7	9.7	10.0	9.3
14.0			7.9	8.2	7.7	7.8	7.5
16.0				6.6	6.6	6.2	5.9
18.0				5.4	5.4	5.0	4.7
20.0					4.4	4.1	3.8
22.0					3.7	3.3	3.0
24.0						2.7	2.4
26.0						2.2	1.9
28.0							1.5
30.0							1.2

%	I	II	III
0	0	50	100
33	0	33	50
50	0	0	33
100	0	0	0

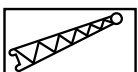
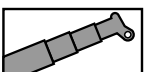

8.8 t

DIN/ISO

m	29.0 m + 9.0 m			32.7 m + 9.0 m		
	5°	20°	40°	5°	20°	40°
8.0	6.0			5.0		
9.0	6.0	4.4		5.0		
10.0	6.0	4.4		5.0	4.0	
11.0	5.7	4.2		4.9	3.9	
12.0	5.3	4.0	2.6	4.7	3.8	2.5
14.0	4.6	3.6	2.5	4.4	3.6	2.5
16.0	4.0	3.2	2.4	4.1	3.3	2.5
18.0	3.5	2.9	2.3	3.9	3.1	2.4
20.0	3.2	2.7	2.2	3.4	2.9	2.3
22.0	2.9	2.5	2.1	3.1	2.6	2.2
24.0	2.5	2.3	2.1	2.6	2.5	2.1
26.0	2.0	2.1	2.0	2.1	2.2	2.1
28.0	1.5	1.6	1.7	1.6	1.7	1.8
30.0	1.2	1.2	1.2	1.2	1.4	1.4
32.0	0.8	0.9	0.8	0.9	1.0	1.0
34.0	0.5	0.5		0.6	0.7	0.7

%	I	II	III
100	100	100	100
50			

Hubhöhen
Lifting heights

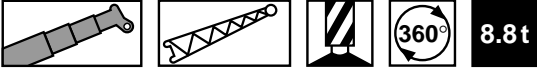

DIN/ISO

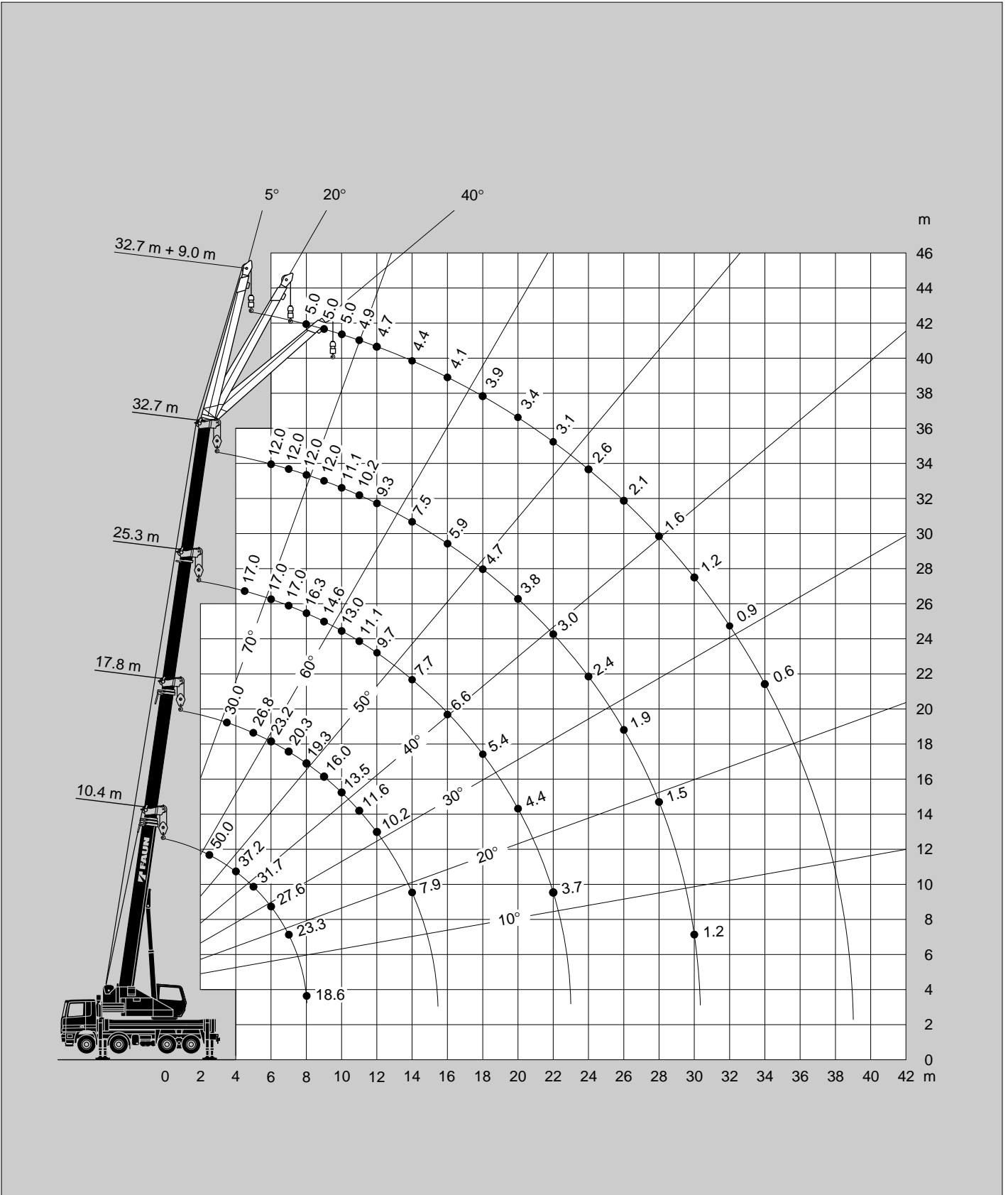

Tragfähigkeiten am Teleskopausleger Lifting capacities on telescopic boom

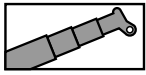

 m	10.4 m	14.1 m	17.8 m	21.6 m	25.3 m	29.0 m	32.7 m
2.5	48.5						
3.0	43.9	30.0					
3.5	39.9	30.0	30.0				
4.0	36.6	30.0	30.0	20.0			
4.5	33.7	30.0	29.1	20.0	17.0		
5.0	29.8	28.8	26.8	20.0	17.0	16.0	
6.0	20.6	19.7	20.0	20.0	17.0	16.0	12.0
7.0	15.4	14.7	16.2	15.6	15.6	15.2	12.0
8.0	12.1	11.4	12.8	13.2	12.9	12.7	12.0
9.0		8.9	10.4	10.7	10.7	10.2	9.8
10.0		7.0	8.5	8.8	8.8	8.3	7.9
11.0		5.6	7.0	7.3	7.3	6.8	6.4
12.0			5.9	6.2	6.2	5.7	5.3
14.0			4.2	4.5	4.5	4.0	3.7
16.0				3.3	3.3	2.9	2.6
18.0				2.5	2.4	2.0	1.7
20.0					1.8	1.4	1.1
22.0					1.3	0.9	0.7
24.0						0.6	

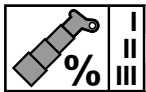

I	0	50	100	33	0	100	50	0	100	66	0	100	50	100
II	0	0	0	33	50	50	50	50	100	66	100	100	100	100
III	0	0	0	33	50	0	50	100	0	66	100	50	100	100

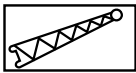
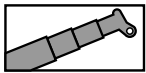

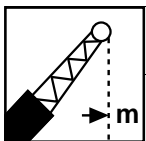
 m	29.0 m + 9.0 m			32.7 m + 9.0 m		
	5°	20°	40°	5°	20°	40°
8.0	6.0			5.0		
9.0	6.0	4.4		5.0		
10.0	6.0	4.4		5.0	4.0	
11.0	5.7	4.2		4.9	3.9	
12.0	5.3	4.0	2.6	4.7	3.8	2.5
14.0	4.0	3.6	2.5	4.1	3.6	2.5
16.0	2.8	3.2	2.4	2.9	3.3	2.5
18.0	1.9	2.2	2.3	2.0	2.4	2.4
20.0	1.3	1.5	1.8	1.4	1.6	1.9
22.0	0.8	1.0	1.2	0.8	1.1	1.3
24.0		0.5	0.7		0.6	0.8

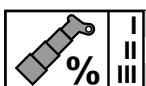

I	100	100
II	100	100
III	50	100

Hubhöhen
Lifting heights

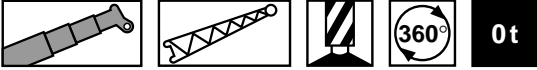

DIN/ISO

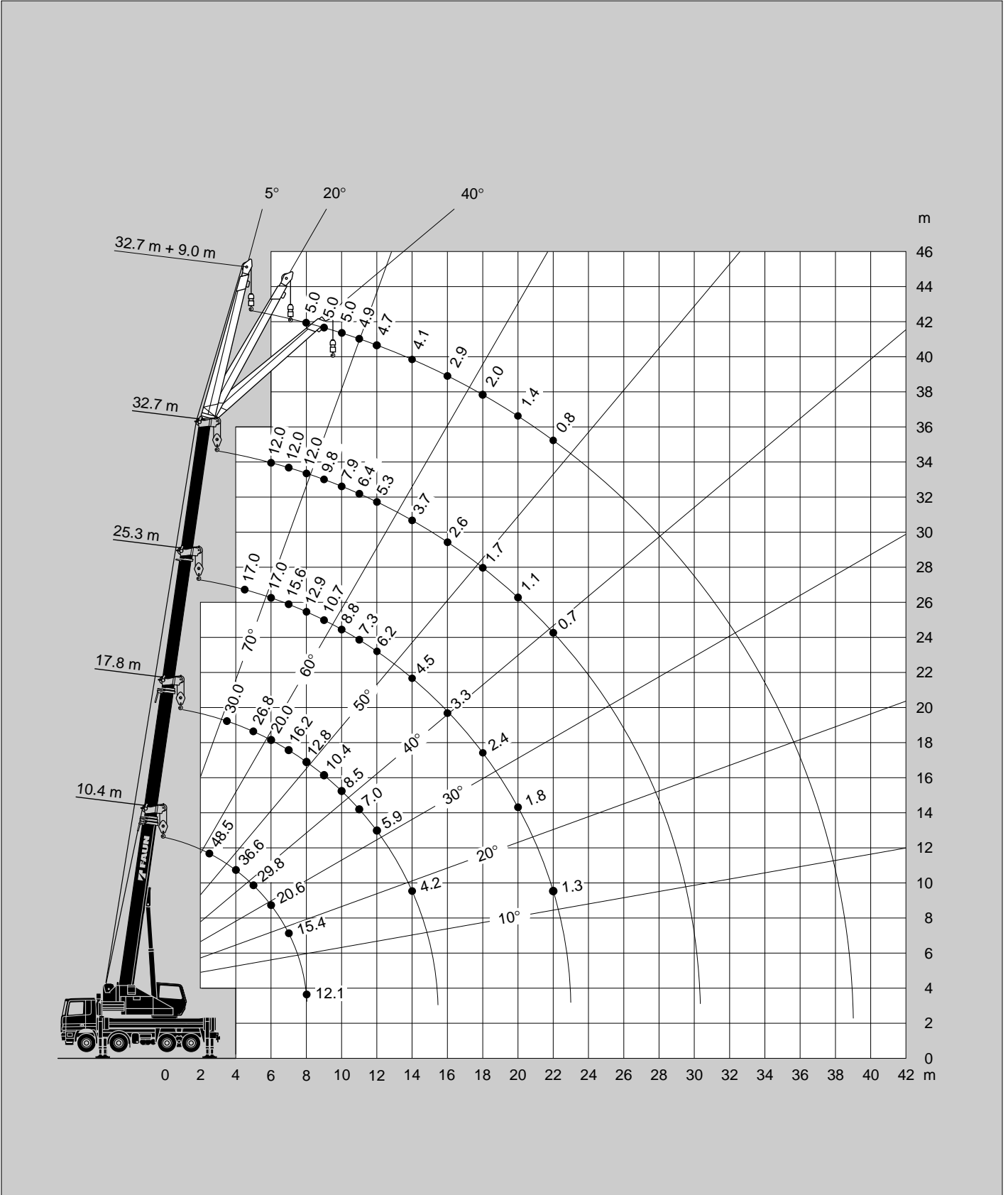

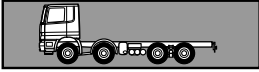

Fahrgestell 4-achsiges handelsübliches MAN oder Mercedes-Benz-Fahrgestell (8 x 4).
Andere Fahrgestelle auf Anfrage.

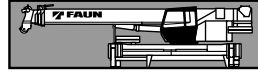

Rahmen Verwindungs- und biegesteife Schweißkonstruktion aus hochfestem Feinkornstahl mit einer außenverzahnten, einreihigen Kugeldrehverbindung, um 360° unbegrenzt drehbar.

Abstützung 4-Punkt-Abstützung, vorne hydraulisch schwenk- und teleskopierbar, hinten nur teleskopierbare Abstützträger, Bedienungsmöglichkeiten an beiden Seiten des Fahrgestelles. Abstützbasis 6,28 m (und 4,3 m) x 6,32 m.

Motor Mercedes-Benz 4-Zylinder-Dieselmotor OM 904 LA (Euromot 2/EPA 2), wassergekühlt. Drehzahl über Fußpedal stufenlos regelbar, Leistung 90 kW (122 PS) bei 2300 min⁻¹. Drehmoment 470 Nm (48 kpm) bei 1200 min⁻¹. Motorleistung nach 80/1269/EWG und DIN 6270B/DIN 6271.

Hydraulik System Diesel-hydraulisch mit 3-Kreis-Hydraulik, 1 leistungsgeregelte Axialkolbendoppelpumpe (hydraulisch verstellbar) und 1 Zahnrad-Doppelpumpe.

Steuerung Zwei 4-fach Kreuzsteuerhebel mit hydraulischer Vorsteuerung.

Teleskopausleger Vierteiliger Teleskopausleger aus hochfestem Feinkornstahl, bestehend aus einem Grundausleger und 3 Teleskopteilen, hydraulisch unter Teillast teleskopierbar. 10,4 m - 32,7 m lang.

Wippwerk Differentialzylinder mit angebautem Senkbremssperrventil.

Hubwerk Axialkolben-Motor, Hubwerkstrommel mit eingebautem Planetengetriebe und federbelasteter Hydro-Lamellenbremse mit integriertem Freilauf beim Heben. Hubseil mit 'Super-Stop' Einrichtung.

Drehwerk Axialkolben-Motor, zweistufiges Planetengetriebe mit fußbetätigter Betriebsbremse und Feststellung. Drehgeschwindigkeit stufenlos von 0 - 2 min⁻¹.

Gegengewicht Standard 8,8 t teilbar. Die Bedienung erfolgt aus der Oberwagenkabine.

Oberwagenkabine Großräumige Krankabine in Stahlblech-ausführung mit Sicherheitsverglasung mit getönten Scheiben, verstellbarem hydraulisch gedämpftem Fahrersitz, motorabhängige Warmwasserheizung und motorunabhängige Zusatzheizung mit Motorvorwärmung, Kontroll- und Bedienungselemente für Kranbetrieb.

Elektrische Anlage 24 V Gleichstrom, 2 Batterien.

Sicherheitseinrichtungen Lastmomentbegrenzung (LMB), Hubendschalter, Windenendschalter, Seilwindendrehmelder, Sicherheitsventile gegen Rohr- und Schlauchbrüche. Sperrventile an Hydraulik-Zylindern.

Zusatzrüstung (gegen Mehrpreis)
Auslegerverlängerung 9 m, abwinkelbar 5°, 20° und 40°, Schwerlastspitze 2 m, 6 t Hakengeschirr, verschiedene Unterflaschen, 2. Hubwerk, motorunabhängige Zusatzheizung, Klimaanlage, Sonderlackierung und Beschriftung.

Weitere Zusatzausrüstung auf Anfrage.

Anmerkungen zu den Traglasttabellen

Die Tragfähigkeiten im Festigkeitsbereich basieren auf DIN 15018 Blatt 2 und Blatt 3 und F.E.M.

Die Tragfähigkeiten im Standsicherheitsbereich entsprechen DIN 15019 Teil 2 / ISO 4305.

Die zulässige Windgeschwindigkeit beträgt maximal 15 m/sec.

Die Tragfähigkeiten sind in metrischen Tonnen angegeben.

Das Gewicht des Lasthakens bzw. der Hakenflasche und weiterer Anschlagmittel ist von der Tragfähigkeit abzuziehen.

Die Tragfähigkeiten für den Teleskopausleger gelten nur bei demon- tierter Spitze.

Die Ausladung ist der horizontale Abstand von Mitte Drehkranz bis Mitte freihängender, nicht schwingender Last.

Tragfähigkeitsänderungen vorbehalten.

Obige Angaben dienen nur zur Information. Die Bedienungsanleitun- gen müssen zu Rate gezogen werden, bevor die Maschine in Betrieb genommen wird. Alle hier gemachten Angaben beziehen sich auf die Standard-Ausführung. Jegliche Ausrüstungsveränderungen können die angegebenen Werte beeinflussen.

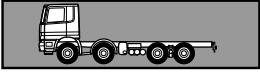

Chassis 4 axle MAN or Mercedes-Benz chassis (8 x 4).
Other chassis on request.

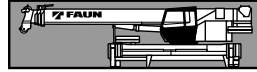

Frame Torsion-resistant, welded construction made from high strength, fine-grained steel. Connected to carrier by single-row ball-bearing slewing ring with external gearing for 360° continuous rotation.

Outriggers 4 point, telescopic hydraulic outriggers with controls on both sides of carrier.
Outrigger base 6.28 m (4.3 m mid extension) x 6.32 m.

Superstructure engine Mercedes-Benz 4 cylinder model OM 904 LA (Euromot 2/EPA 2), water cooled, diesel engine. Engine speed infinitely controlled via pedal. Rated at 90 kW (122 HP) at 2300 min⁻¹. Torque 470 Nm (48 kpm) at 1200 min⁻¹. Engine rating according to 80/1269/EWG and DIN 6270B/DIN 6271.

Hydraulic system Three circuit diesel hydraulic system with 1 power controlled axial piston double pump (hydraulically adjustable) and 1 double gear pump.

Controls Hydraulic, 2 joy-stick levers for simultaneous and independent operation of 4 crane motions.

Telescopic boom 4 sections, made of high tensile, fine-grained steel, consisting of 1 base section and 3 telescoping sections. All telescope sections extendable under partial load. 10.4 m to 32.7 m long.

Derricking system 1 double acting hydraulic cylinder with integral brake and holding valve.

Main winch Axial piston motor, winch drum with integrated planetary reduction and with hydraulically controlled spring-loaded, multiple disc brake and with integrated free rotation (no sagging of load when hoisting).
Hoist cable with 'Super-Stop' easy reeving system.

Slewing system Axial piston motor with two-stage planetary reduction with a foot actuated service and a parking brake. Speed infinitely variable 0 - 2 min⁻¹.

Counterweight Standard 8.8 t divisible, assembled and disassembled by hydraulic cylinders controlled from superstructure cab.

Superstructure cab Spacious all-steel panoramic cab with safety (tinted) glass windows, hydraulically cushioned adjustable seat, engine dependent hot-water heater and engine independent additional heater with engine pre-heat, complete controls and instrumentation for crane operation.

Electrical system 24 volt DC system, 2 batteries.

Safety devices Load moment device (LMD), hoist limit switch, lower limit switch, drum turn indicator, safety valves against pipe and hose rupture. Holding valves on hydraulic cylinders.

Optional Equipment (at extra charge)
Boom extension 9 m long, offsets 5°, 20° and 40°, heavy duty jib 2 m, 6 t swivel hook, selection of hook blocks, auxiliary winch, engine independent additional heater, air conditioning, special painting and lettering.

Further optional equipment available upon request.

Remarks concerning the load charts

The lifting capacities in the structural area are based on DIN 15018 parts 2 and 3 and F.E.M.

The lifting capacities in the stability area are based on DIN 15019 part 2 / ISO 4305.

The maximum permissible wind speed for crane operation is 15 m/sec.

The lifting capacities shown are in metric tons.











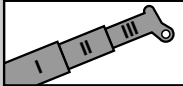

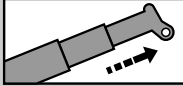

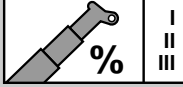
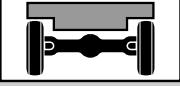
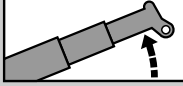

The weight of load handling devices such as hook blocks, slings, etc., must be considered as part of the load and must be deducted from the lifting capacities.

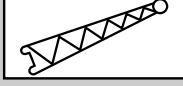
The lifting capacities for the telescopic boom apply to a crane with no boom extensions being stowed or mounted on the crane.

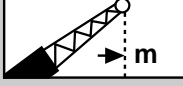
The working radius is the horizontal distance from the centre of rotation to the centre of the freely suspended non-oscillating load.

The lifting capacities are subject to change without prior notice.

The above remarks are for basic information only and the operator's manual must be consulted before operating this crane. All data and performances refer to the standard crane. The addition of optional and other equipment may affect the performance of the crane.

DIN / ISO	Siehe Seite 8 As on Page 9		Teleskopausleger Telescopic boom
	Abstützung Outriggers		Teleskopieren Boom telescoping
	Getriebe / Gang Transmission / Gear		Teleskopieren in % Boom telescoping in %
	Achslast Axle load		Wippwerk Derricking system
	Räder / Größe Tyres / Size		Ausladung Radius
	Gelände Off road		Auslegerverlängerung Boom extension
	Straße On road		Ausladung Radius
V+	Geschwindigkeiten Speeds		Hubwerk Main winch
	Steigfähigkeit Gradeability		2. Hubwerk Auxiliary winch
	Drehwerk Slewing system		Unterflasche / Hakengeschirr Hook block / Swivel hook
8.8t	Gegengewicht Counterweight		