



GR-300EX

Left hand steering

GENERAL DATA

CRANE CAPACITY		30,000 kg at 3.0 m
BOOM		4-section, 9.7 m - 31.0 m
DIMENSION		
Overall length	approx.	11,245 mm
Overall width	approx.	2,620 mm
Overall height	approx.	3,535 mm
MASS		
Gross vehicle mass	approx.	26,940 kg
— front axle	approx.	13,640 kg
— rear axle	approx.	13,300 kg
PERFORMANCE		
Max. travelling speed	computed	47 km/h
Gradeability(tan θ)	computed	93 % (at stall) *57 %

*Machine should be operated within the limit of engine crankcase design (30°: Cummins QSB6.7)

CRANE SPECIFICATIONS

MODEL

GR-300EX

CAPACITY

30,000 kg at 3.0 m

BOOM

4-section full power partially synchronized telescoping boom of round hexagonal box construction with 4 sheaves at boom head. The synchronization system consists of 2 telescope cylinders, extension cables and retraction cables.

Hydraulic cylinders fitted with holding valves.

Fully retracted length	9.7 m
Fully extended length	31.0 m
Extension speed	21.3 m in 91 s

JIB

2-staged swingaround boom extension. Triple offset (5°/25°/45°) type. Box type top section telescopes from lattice type base section which stores alongside base boom section. Single sheave at jib head.

Length.....	7.2 m and 12.8 m
-------------	------------------

SINGLE TOP (AUXILIARY BOOM SHEAVE)

Single sheave. Mounted to main boom head for single line work.

ELEVATION

By a double-acting hydraulic cylinder, fitted with holding valve.

Elevation speed.....0° to 81° in 44 s

HOIST— Main winch

Variable speed type with grooved drum driven by hydraulic axial piston motor through winch speed reducer. Power load lowering and hoisting.

Equipped with automatic brake (Neutral brake) and counterbalance valve. Controlled independently of auxiliary winch.

Single line pull	38.2 kN {3,900 kgf}
Single line speed	118 m/min (at the 4th layer)
Wire rope	Spin-resistant type
Diameter x length	16 mm x 170 m

TADANO LTD.

HOIST—Auxiliary winch

Variable speed type with grooved drum driven by hydraulic axial piston motor through winch speed reducer. Power load lowering and hoisting.

Equipped with automatic brake (Neutral brake) and counter-balance valve. Controlled independently of main winch.

- Single line pull38.2 kN {3,900 kgf}
- Single line speed118 m/min (at the 4th layer)
- Wire ropeSpin-resistant type
- Diameter x length16 mm x 98 m

SWING

Hydraulic axial piston motor driven through planetary speed reducer. Continuous 360° full circle swing on ball bearing slew ring. Equipped with manually locked/released swing brake.

- Swing speed2.7 min⁻¹ {rpm}

HYDRAULIC SYSTEM

Pumps2 variable piston pumps for telescoping, elevating and winches.

Tandem gear pump for steering, swing and optional equipment.

Control valvesMultiple valves actuated by pilot pressure with integral pressure relief valves.

CircuitEquipped with air cooled type oil cooler. Oil pressure appears on AML display for main circuit.

Hydraulic oil tank capacity approx. 380 liters

FiltersReturn line filter

CRANE CONTROL

By 4 control levers for swing, boom hoist, main winch, boom telescoping or auxiliary winch with 2 control pedals for boom hoist and boom telescoping based on ISO standard layout.

Control lever stands can change neutral positions and tilt for easy access to cab.

CAB

Both crane and drive operations can be performed from one cab mounted on rotating superstructure. One sided one-man type, steel construction with sliding door access and tinted safety glass windows opening at side. Door window is powered control.

Operator's 3 way adjustable seat with headrest and armrest.

TADANO Automatic Moment Limiter (Model:AML-L)

Main unit in crane cab gives audible and visual warning of approach to overload. Automatically cuts out crane motions before overload.

With working range (load radius and/or boom angle and/or tip height and/or swing range) limit function.

Nine functions are displayed.

Digital liquid crystal display:

- Either boom angle or moment %
- Either boom length or potential hook height
- Either actual load radius or swing angle
- Actual hook load
- Permissible load
- Either jib offset angle or number of parts line of rope
- Boom position indicator
- Either outrigger position or on-tire indicator

Bar graphical display:

- Either moment as percentage or main hydraulic pressure (Display changes by alternation key on the AML front panel)

OUTRIGGERS

4-Hydraulically operated H-type outriggers. Each outrigger controlled simultaneously or independently from the cab. Equipped with sight level gauge. Floats mounted integrally with the jacks retract to within vehicle width.

All cylinders fitted with pilot check valves.

Crane operation with different extended length of each outrigger. Equipped with extension width detector for each outrigger.

- Extended width
 - Fully6,300 mm
 - Middle5,900 mm
 - Middle5,000 mm
 - Minimum2,200 mm
- Float size(Diameter)400 mm

COUNTERWEIGHT

Integral with swing frame

- Mass2,380 kg

NOTE : Each crane motion speed is based on unladen conditions.

TYPE

Rear engine, left hand steering, driving axle 2-way selected type (by manual switch).

- 4 x 2 front drive
- 4 x 4 front and rear drive

FRAME

High-tensile steel, all welded mono-box construction.

ENGINE

Model.....Cummins QSB6.7 [EUROMOT Stage IIIA]
Type.....4 cycle, turbo charged and after cooled, 6 cylinder in line, direct injection, water cooled diesel engine.
Piston displacement6,700 cm³
Bore x stroke107 mm x 124 mm
Max. output.....160 kW {217 PS} at 2,500 min⁻¹ {rpm}
Max. torque843 N-m {86 kgf-m} at 1,600 min⁻¹ {rpm}

TRANSMISSION

Electronically controlled full automatic transmission.
Torque converter driving full powershift with driving axle selector. 8 forward and 2 reverse speeds.
4 speeds - High range - 2 wheel drive ; 4 wheel drive
4 speeds - Low range - 4 wheel drive

AXLES

Front.....Full floating type, steering and driving axle with planetary reduction.
Rear.....Full floating type, steering and driving axle with planetary reduction.
Non-spin differential.

STEERING

Hydraulic power steering controlled by steering wheel.
Three steering modes available:
2-wheel front
4-wheel coordinated
4-wheel crab

SUSPENSION

FrontSemi-elliptic leaf springs with hydraulic lockout device.
Rear.....Semi-elliptic leaf springs with hydraulic lockout device.

BRAKE SYSTEM

ServiceAir over hydraulic disc brakes on all 4 wheels.
Parking / Emergency.....
Spring applied-air released brake acting on input shaft of front axle.
Auxiliary....Electro-pneumatic operated exhaust brake.

ELECTRIC SYSTEM

24 V DC. 2 batteries of 12 V - 120 Ah capacity.

FUEL TANK CAPACITY

300 liters

TIRES

Front445 / 95 R 25(OR), Single x 2
Rear.....445 / 95 R 25(OR), Single x 2

TURN RADIUS

Min. turning radius (at center of extreme outer tire)
2-wheel steering 9.55 m
4-wheel steering 5.7 m

EQUIPMENT

STANDARD EQUIPMENT

Automatic moment limiter (AML-L)
External lamp (AML)
Pendant type over-winding cutout
Winch automatic fail-safe brake
Cable follower
30 t capacity hook block (4 sheaves)
3.9 t capacity hook block (swivel hook)
Hook safety latch
Pilot check valves
Holding valves
Counterbalance valves
Hydraulic pressure relief valves
Swing brake
Swing lock (360° swing lock)
Boom angle indicator
Boom elevation foot pedal
Boom telescoping foot pedal
Outrigger extension width detector
Sight level gauge
Hydraulic oil cooler
Electric windshield wiper and washer
Roof window wiper and washer
Power window (Cab door)
Tachometer/Speedometer

3 way adjustable cloth seat with seat belt, headrest and armrest
Cab floor mat
Sun visor (Front and roof)
Automatic drive system
Transmission neutral position engine start
Overshift prevention
Parking braked travel warning
Tilt-telescope steering wheel
Back-up alarm
Air cleaner dust indicator
Air dryer
Water separator with filter
Engine over-run alarm
Hydraulic lockout suspension
Non-spin differential (Rear)
Towing eyes - front and rear

OPTIONAL EQUIPMENT

- Winch drum rotation indicator for main and auxiliary winch
- Air conditioner (hot water heater and cooler)
- Electric fan
- Tire inflation kit
- Emergency steering

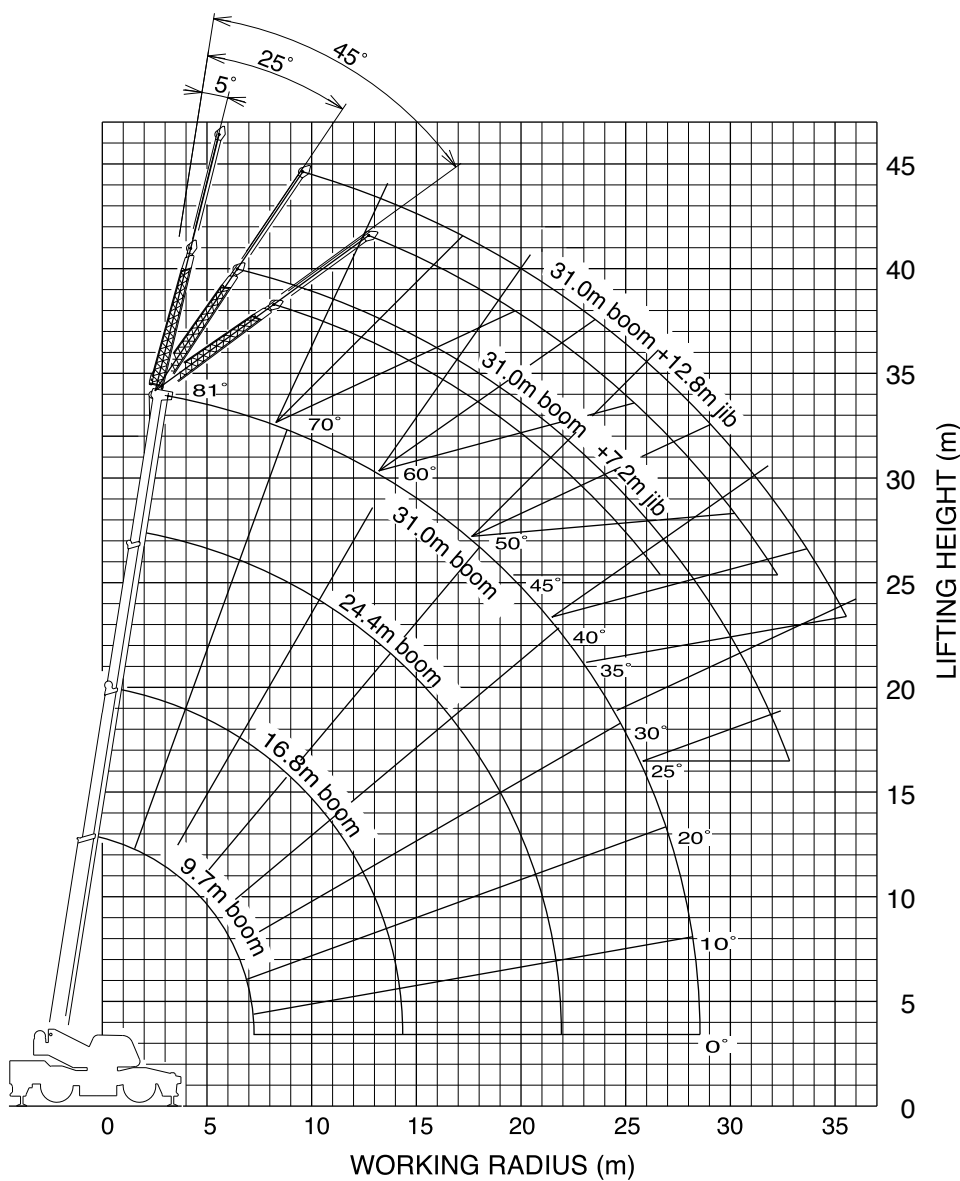

BOOM

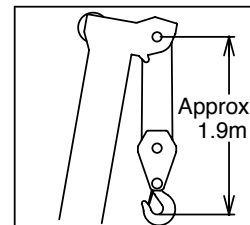

JIB

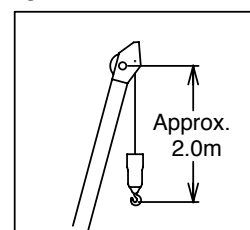

SINGLE TOP

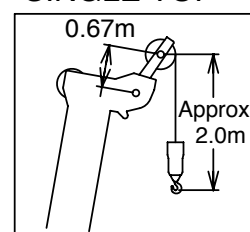

Boom Length

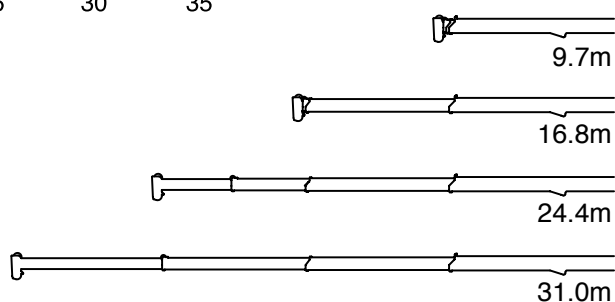

NOTE: The above lifting height and boom angle are based on a straight (unladen) boom, and allowance should be made for boom deflection obtained under laden conditions. The above working range is shown on condition with outriggers fully (6.3m) extended.

ON OUTRIGGERS

Unit: kg

Outriggers fully extended (6.3m) 360° Rotation								
B	9.7		16.8		24.4		31.0	
	C		C		C		C	
3.0	60.6	30,000	74.4	19,200	79.7	12,500		
3.5	57.0	27,200	72.5	19,200	78.5	12,500		
4.0	53.1	23,400	70.9	19,200	77.5	12,500	80.8	8,400
4.5	49.2	21,300	68.9	18,300	76.3	12,500	80.0	8,400
5.0	44.7	19,600	67.1	17,000	75.0	12,500	79.1	8,400
5.5	40.3	18,100	65.1	15,800	74.0	12,500	78.3	8,400
6.0	34.9	16,600	63.3	14,700	72.8	12,500	77.3	8,400
6.5	28.7	15,200	61.4	13,600	71.5	11,700	76.6	8,400
7.0	18.3	14,100	59.4	12,900	70.3	11,000	75.6	8,100
8.0			54.9	10,900	67.7	9,750	73.7	7,500
9.0			50.5	9,000	65.0	8,750	71.8	6,800
10.0			45.8	7,050	62.4	7,900	69.8	6,200
11.0			40.3	5,800	59.5	6,600	67.6	5,800
12.0			34.3	4,800	56.5	5,600	65.6	5,400
13.0			27.0	4,050	53.6	4,750	63.5	5,000
14.0			15.7	3,400	50.4	4,150	61.3	4,400
15.0					47.0	3,600	59.0	3,850
16.0					43.4	3,200	56.6	3,450
17.0					39.6	2,750	54.2	3,050
18.0					35.5	2,450	51.8	2,650
19.0					30.7	2,050	49.2	2,400
20.0					25.6	1,800	46.6	2,100
22.0							40.8	1,700
24.0							34.4	1,300
26.0							26.2	1,000
28.0							13.4	500
D								0°

- A: Boom length (m)
- B: Load radius (m)
- C: Loaded boom angle (°)
- D: Minimum boom angle for indicated boom length (no load)

ON OUTRIGGERS

Unit: kg

Outriggers fully extended (6.3m) 360° Rotation												
C	31.0m Boom + 7.2m Jib						31.0m Boom + 12.8m Jib					
	5°offset		25°offset		45°offset		5°offset		25°offset		45°offset	
	R	W	R	W	R	W	R	W	R	W	R	W
80°	5.9	3,500	8.1	2,400	9.8	1,700	7.7	2,200	11.7	1,200	14.6	800
77.5°	7.7	3,500	9.8	2,300	11.4	1,650	9.8	2,150	13.5	1,150	16.3	780
75°	9.4	3,500	11.4	2,200	12.9	1,600	11.8	2,100	15.3	1,100	17.9	750
72.5°	11.2	3,230	13.0	2,100	14.4	1,550	13.6	1,930	17.1	1,050	19.4	730
70°	12.7	2,950	14.6	2,000	15.8	1,500	15.5	1,750	18.8	1,000	21.0	700
67.5°	14.3	2,750	16.1	1,930	17.2	1,450	17.2	1,630	20.5	950	22.5	680
65°	15.8	2,550	17.5	1,850	18.6	1,400	18.9	1,500	22.0	900	23.9	650
62.5°	17.3	2,350	19.0	1,800	19.9	1,380	20.6	1,400	23.6	880	25.2	650
60°	18.7	2,150	20.4	1,750	21.2	1,350	22.3	1,300	25.1	850	26.6	650
57.5°	20.0	1,950	21.6	1,650	22.4	1,330	23.8	1,230	26.4	800	27.8	650
55°	21.4	1,750	22.9	1,550	23.6	1,300	25.4	1,150	27.9	750	29.0	650
52.5°	22.6	1,550	24.0	1,380	24.7	1,230	26.8	1,100	29.2	730	30.2	630
50°	23.9	1,350	25.2	1,200	25.7	1,150	28.3	1,050	30.5	700	31.4	600
47.5°	25.0	1,180	26.3	1,100	26.7	1,100	29.6	900	31.7	680	32.5	600
45°	26.0	1,000	27.3	1,000	27.7	1,000	30.8	750	32.8	650	33.5	600
42.5°	27.1	900	28.2	900			32.0	680	33.8	600		
40°	28.1	800	29.1	800			33.1	600	34.8	550		
37.5°	29.0	700	30.0	700			34.2	530	35.7	480		
35°	30.0	600	30.8	600			35.2	450	36.5	400		
32.5°	30.8	530	31.5	530			36.1	400				
30°	31.6	450	32.2	450			37.0	350				
27.5°	32.3	400	32.8	380								
25°	33.0	350	33.4	300								

- C: Boom angle
- R: Load radius (m)
- W: Rated lifting capacity

RATED LIFTING CAPACITIES ISO4305

SPEC. SHEET NO. GR-300E-1-00212/EX-41

ON OUTRIGGERS

Unit: kg

Outriggers extended to middle (5.9m) 360° Rotation									
B	A	9.7		16.8		24.4		31.0	
	C		C		C		C		
3.0	60.6	30,000	74.4	19,200	79.7	12,500			
3.5	57.0	27,200	72.5	19,200	78.5	12,500			
4.0	53.1	23,400	70.9	19,200	77.5	12,500	80.8	8,400	
4.5	49.2	21,300	68.9	18,300	76.3	12,500	80.0	8,400	
5.0	44.7	19,600	67.1	17,000	75.0	12,500	79.1	8,400	
5.5	40.3	18,100	65.1	15,800	74.0	12,500	78.3	8,400	
6.0	34.9	16,600	63.3	14,700	72.8	12,500	77.3	8,400	
6.5	28.7	15,200	61.4	13,600	71.5	11,700	76.6	8,400	
7.0	18.3	12,900	59.4	12,600	70.3	11,000	75.6	8,100	
8.0			54.9	9,650	67.7	9,750	73.7	7,500	
9.0			50.5	7,700	65.0	8,750	71.8	6,800	
10.0			45.8	6,250	62.1	7,050	69.8	6,200	
11.0			40.3	5,150	59.4	5,950	67.6	5,800	
12.0			34.3	4,200	56.5	4,950	65.5	5,300	
13.0			27.0	3,500	53.4	4,200	63.2	4,500	
14.0			15.7	2,900	50.2	3,550	61.1	3,850	
15.0					46.9	3,050	58.8	3,350	
16.0					43.3	2,600	56.5	2,850	
17.0					39.5	2,250	54.0	2,500	
18.0					35.2	1,850	51.6	2,200	
19.0					30.6	1,600	49.1	1,850	
20.0					25.1	1,350	46.4	1,600	
22.0							40.4	1,150	
24.0							33.6	800	
26.0							25.6	550	
D								0°	

A: Boom length (m)

B: Load radius (m)

C: Loaded boom angle (°)

D: Minimum boom angle for indicated boom length (no load)

ON OUTRIGGERS

Unit: kg

Outriggers extended to middle (5.9m) 360° Rotation												
C	31.0m Boom + 7.2m Jib						31.0m Boom + 12.8m Jib					
	5°offset		25°offset		45°offset		5°offset		25°offset		45°offset	
	R	W	R	W	R	W	R	W	R	W	R	W
80°	5.9	3,500	8.1	2,400	9.8	1,700	7.7	2,200	11.7	1,200	14.6	800
77.5°	7.7	3,500	9.8	2,300	11.4	1,650	9.8	2,150	13.5	1,150	16.3	780
75°	9.4	3,500	11.4	2,200	12.9	1,600	11.8	2,100	15.3	1,100	17.9	750
72.5°	11.2	3,230	13.0	2,100	14.4	1,550	13.6	1,930	17.1	1,050	19.4	730
70°	12.7	2,950	14.6	2,000	15.8	1,500	15.5	1,750	18.8	1,000	21.0	700
67.5°	14.3	2,750	16.1	1,930	17.2	1,450	17.2	1,630	20.5	950	22.5	680
65°	15.8	2,550	17.5	1,850	18.6	1,400	18.9	1,500	22.0	900	23.9	650
62.5°	17.3	2,350	19.0	1,800	19.9	1,380	20.6	1,400	23.6	880	25.2	650
60°	18.7	2,150	20.4	1,750	21.2	1,350	22.3	1,300	25.1	850	26.6	650
57.5°	20.0	1,880	21.6	1,600	22.4	1,330	23.8	1,230	26.4	800	27.8	650
55°	21.4	1,600	22.9	1,450	23.6	1,300	25.4	1,150	27.9	750	29.0	650
52.5°	22.6	1,350	24.0	1,250	24.7	1,150	26.8	1,000	29.2	730	30.2	630
50°	23.9	1,100	25.1	1,050	25.7	1,000	28.2	850	30.4	700	31.3	600
47.5°	25.0	950	26.1	900	26.7	880	29.5	730	31.6	630	32.3	550
45°	26.0	800	27.1	750	27.7	750	30.7	600	32.7	550	33.3	500
42.5°	27.1	680	28.1	630			31.9	480	33.7	450		
40°	28.1	550	29.0	500			33.1	350	34.7	350		
37.5°	29.0	480	29.8	430								
35°	30.0	400	30.7	350								

C: Boom angle (°)

R: Load radius (m)

W: Rated lifting capacity

ON OUTRIGGERS

Unit: kg

Outriggers extended to middle (5.0m) 360° Rotation									
B	A	9.7		16.8		24.4		31.0	
		C		C		C		C	
3.0		60.6	30,000	74.4	19,200	79.7	12,500		
3.5		57.0	27,200	72.5	19,200	78.5	12,500		
4.0		53.1	23,400	70.9	19,200	77.5	12,500	80.8	8,400
4.5		49.2	21,300	68.9	18,300	76.3	12,500	80.0	8,400
5.0		44.7	19,600	67.1	17,000	75.0	12,500	79.1	8,400
5.5		40.3	15,700	65.1	15,000	74.0	12,500	78.3	8,400
6.0		34.9	13,200	63.3	12,650	72.8	12,500	77.3	8,400
6.5		28.7	11,300	61.4	10,850	71.5	11,700	76.6	8,400
7.0		18.2	9,650	59.4	9,500	70.1	10,400	75.6	8,100
8.0				54.9	7,300	67.5	8,200	73.7	7,500
9.0				50.5	5,800	64.8	6,700	71.8	6,800
10.0				45.8	4,700	62.0	5,500	69.5	5,800
11.0				40.3	3,800	59.3	4,650	67.3	4,900
12.0				34.3	3,100	56.3	3,900	65.2	4,250
13.0				27.0	2,550	53.0	3,250	63.0	3,600
14.0				15.7	1,900	49.9	2,750	60.8	3,100
15.0						46.6	2,300	58.5	2,650
16.0						43.0	1,900	56.1	2,250
17.0						39.4	1,600	53.8	1,950
18.0						35.2	1,350	51.3	1,650
19.0						30.5	1,100	48.7	1,400
20.0						24.9	750	46.0	1,200
22.0								40.3	800
D				0°				26°	

- A: Boom length (m)
- B: Load radius (m)
- C: Loaded boom angle (°)
- D: Minimum boom angle for indicated boom length (no load)

ON OUTRIGGERS

Unit: kg

Outriggers extended to middle (5.0m) 360° Rotation												
C	31.0m Boom + 7.2m Jib						31.0m Boom + 12.8m Jib					
	5°offset		25°offset		45°offset		5°offset		25°offset		45°offset	
	R	W	R	W	R	W	R	W	R	W	R	W
80°	5.9	3,500	8.1	2,400	9.8	1,700	7.7	2,200	11.7	1,200	14.6	800
77.5°	7.7	3,500	9.8	2,300	11.4	1,650	9.8	2,150	13.5	1,150	16.3	780
75°	9.4	3,500	11.4	2,200	12.9	1,600	11.8	2,100	15.3	1,100	17.9	750
72.5°	11.2	3,230	13.0	2,100	14.4	1,550	13.6	1,930	17.1	1,050	19.4	730
70°	12.7	2,950	14.6	2,000	15.8	1,500	15.5	1,750	18.8	1,000	21.0	700
67.5°	14.3	2,700	16.1	1,930	17.2	1,450	17.2	1,630	20.5	950	22.5	680
65°	15.8	2,450	17.5	1,850	18.6	1,400	18.9	1,500	22.0	900	23.9	650
62.5°	17.1	2,050	18.9	1,650	19.9	1,380	20.6	1,380	23.6	880	25.2	650
60°	18.6	1,650	20.2	1,450	21.1	1,350	22.2	1,250	25.1	850	26.6	650
57.5°	19.8	1,380	21.5	1,230	22.3	1,150	23.7	1,030	26.5	750	27.8	650
55°	21.1	1,100	22.7	1,000	23.4	950	25.1	800	27.7	650	29.0	650
52.5°	22.4	930	23.9	830	24.5	800	26.5	650	29.0	550	30.2	550
50°	23.6	750	25.0	650	25.5	650	27.9	500	30.3	450	31.2	450
47.5°	24.8	600	26.1	500	26.6	500						
45°	25.9	450	27.1	350	27.5	350						

- C: Boom angle (°)
- R: Load radius (m)
- W: Rated lifting capacity

ON OUTRIGGERS

Unit: kg

Outrigger extended to minimum (2.2m) 360° Rotation								
B \ A	9.7		16.8		24.4		31.0	
	C		C		C		C	
3.0	60.6	13,200	74.2	13,000	79.5	12,500		
3.5	57.0	10,250	72.2	9,800	78.4	10,900		
4.0	53.1	8,000	70.5	7,800	77.2	8,800	79.9	8,000
4.5	49.2	6,700	68.4	6,450	75.9	7,250	79.0	7,200
5.0	44.7	5,700	66.8	5,300	74.6	6,200	77.9	6,050
5.5	40.3	4,700	64.6	4,400	73.3	5,200	77.0	5,450
6.0	34.9	3,850	62.8	3,650	72.0	4,400	76.1	4,800
6.5	28.7	3,300	60.9	3,050	70.6	3,800	75.1	4,250
7.0	18.3	2,700	58.7	2,600	69.5	3,300	74.1	3,650
8.0			54.6	1,850	66.7	2,400	72.3	2,750
9.0			50.2	1,200	64.1	1,750	70.3	2,050
10.0			45.1	550	61.3	1,350	68.3	1,500
11.0					58.7	950	66.2	1,200
12.0					55.9	550	64.3	900
13.0							62.2	500
D	0°		40°		53°		60°	

- A: Boom length (m)
- B: Load radius (m)
- C: Loaded boom angle (°)
- D: Minimum boom angle for indicated boom length (no load)

NOTES FOR “ON OUTRIGGERS” TABLE

1. Rated lifting capacities shown in the table are based on condition that crane is set on firm level surface. Those above bold lines are based on crane strength and those below, on its stability.
2. Rated lifting capacities based on crane stability are according to ISO 4305.
3. The mass of the hook (270kg for 30 t capacity, 100kg for 3.9 t capacity), slings and all similarly used load handling devices must be considered as part of the load and must be deducted from the lifting capacities.
4. For rated lifting capacity of single top, reduce the rated lifting capacities of relevant boom according to a weight reduction for auxiliary load handling equipment. Capacities of single top shall not exceed 3,900 kg including main boom hook mass and the net capacity must be so reduced.
5. Standard number of parts line for each boom length is as shown below. Load per line should not surpass 38.2 kN {3,900 kgf} for main winch and auxiliary winch.

Boom length	9.7m	9.7m to 16.8m	16.8m to 31.0m	Single top / Jib
Number of parts line	9	6	4	1

The lifting capacity data stored in the AUTOMATIC MOMENT LIMITER (AML-L) is based on the standard number of parts line listed in the chart.

Maximum lifting capacity is restricted by the number parts line of AUTOMATIC MOMENT LIMITER (AML-L).

6. The lifting capacity for over-side area differs depending on the outrigger extension width. Work with the capacity corresponding to the extension width. The lifting capacities for over-front and over-rear areas are for “outriggers fully extended”. However, the areas (angle a) differ depending on the outrigger extension width.

Outriggers extended width	5.9m(middle)	5.0m(middle)	2.2m(minimum)
Angle a°	45	40	15

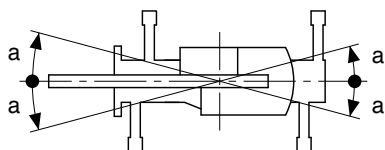

RATED LIFTING CAPACITIES ISO4305

SPEC. SHEET NO. GR-300E-1-00212/EX-41

ON TIRES

Unit: kg

A \ B		Stationary										
		Over Front						360° Rotation				
		9.7		16.8		24.4		9.7		16.8		24.4
C		C		C		C		C		C		
3.0	60.6	18,000					60.6	11,000				
3.5	56.8	17,000					57.1	9,000				
4.0	53.0	15,000					53.5	7,300				
4.5	49.2	12,700	68.8	11,000			49.7	5,700	68.5	5,500		
5.0	44.9	10,600	66.9	9,500			45.4	4,900	66.3	4,500		
5.5	39.9	9,000	64.9	8,000			40.8	4,000	64.6	3,700		
6.0	34.6	7,700	63.1	7,000			35.3	3,200	62.5	3,100		
6.5	27.7	6,600	61.1	6,100			28.9	2,750	60.9	2,500		
7.0	17.7	5,700	59.0	5,300			20.5	2,270	58.6	2,100		
8.0			54.6	4,250	67.2	5,000			54.6	1,400	66.9	2,200
9.0			50.0	3,450	64.3	3,900			49.9	850	64.3	1,600
10.0			45.2	2,650	61.6	3,150					61.6	1,100
11.0			40.1	2,100	58.8	2,550					58.7	800
12.0			33.8	1,600	55.9	2,100						
13.0			26.5	1,200	52.9	1,750						
14.0			15.7	750	49.7	1,400						
15.0					46.7	1,100						
16.0					43.1	850						
17.0					39.4	600						
D			0°		28°		0°		44°		56°	

- A: Boom length (m)
- B: Load radius (m)
- C: Loaded boom angle (°)
- D: Minimum boom angle for indicated boom length (no load)

ON TIRES

Unit:kg

A \ B		Creep										
		Over Front						360° Rotation				
		9.7		16.8		24.4		9.7		16.8		24.4
C		C		C		C		C		C		
3.0	60.6	18,000					60.6	10,000				
3.5	56.8	15,450					57.0	8,000				
4.0	53.0	13,000					53.3	6,500				
4.5	49.0	11,100	68.6	9,700			49.2	5,100	68.6	5,100		
5.0	44.7	9,300	66.6	8,400			44.4	4,300	66.6	4,200		
5.5	39.8	7,950	64.6	7,000			39.6	3,700	64.7	3,500		
6.0	34.7	6,700	62.8	6,000			34.0	3,000	62.7	2,700		
6.5	28.0	5,750	60.8	5,300			27.0	2,500	60.7	2,350		
7.0	18.2	5,000	58.7	4,650			18.1	1,950	58.9	1,850		
8.0			54.4	3,600	67.0	4,300			54.5	1,300	67.0	1,900
9.0			49.9	2,800	64.3	3,400			50.2	750	64.3	1,350
10.0			45.1	2,300	61.7	2,800					61.7	900
11.0			39.6	1,800	58.8	2,250					58.8	600
12.0			33.3	1,350	56.0	1,800						
13.0			26.0	1,000	52.9	1,500						
14.0			14.6	600	49.7	1,200						
15.0					46.4	950						
16.0					42.9	600						
D			0°		31°		0°		44°		56°	

- A: Boom length (m)
- B: Load radius (m)
- C: Loaded boom angle (°)
- D: Minimum boom angle for indicated boom length (no load)

NOTES FOR “ON TIRES” TABLE

1. Rated lifting capacities shown in the table are based on condition that crane is set on firm level surface, with suspension lock applied. Those above bold lines are based on tire capacity and those below, on crane stability. They are based on actual working radii increased by tire deformation and boom deflection.
2. Rated lifting capacities based on crane stability are according to ISO 4305.
3. The mass of the hook (270 kg for 30 t capacity, 100 kg for 3.9 t capacity), slings and all similarly used load handling devices must be considered as part of the load and must be deducted from the lifting capacities.
4. For rated lifting capacity of single top, reduce the rated lifting capacities of relevant boom according to weight reductions for auxiliary load handling equipment. Capacities of single top shall not exceed 3,900 kg including main hook.
5. On tires lifting with "jib" is not permitted. Maximum permissible boom length is 24.4 m.
6. CREEP is motion for crane not to travel more than 60 m in any 30 minute period and to travel at the speed of less than 1.6 km/h.
7. During "CREEP" duties travel slowly and keep the lifting load as close to the ground as possible, and especially avoid any abrupt steering, accelerating or braking.
8. Do not operate the crane while carrying the load.
9. Tires should be inflated to their correct air pressure of 0.9 MPa {9.0 kgf/cm²}.
10. For CREEP operation, set Drive select switch to "4-WHEEL(Lo)" and set gear shift lever to "1".
11. Standard number of parts of line for on tires operation should be according to the following table.
Load per line should not surpass 38.2 kN {3,900 kgf} for main winch and auxiliary winch.

Boom length	Over Front			360° Rotation		
	9.7m	16.8m	24.4m	9.7m	16.8m	24.4m
Number of parts line (Single top)	6 (1)	4 (1)	4 (1)	4 (1)	4 (1)	4 (1)

The lifting capacity data stored in the AUTOMATIC MOMENT LIMITER (AML-L) is based on the standard number of parts line listed in the chart.

Maximum lifting capacity is restricted by the number of parts line of AUTOMATIC MOMENT LIMITER (AML-L).

WORKING AREA

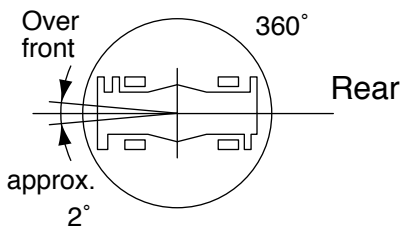

Without outriggers "Over front" operation should be performed within 2 degrees in front of chassis..

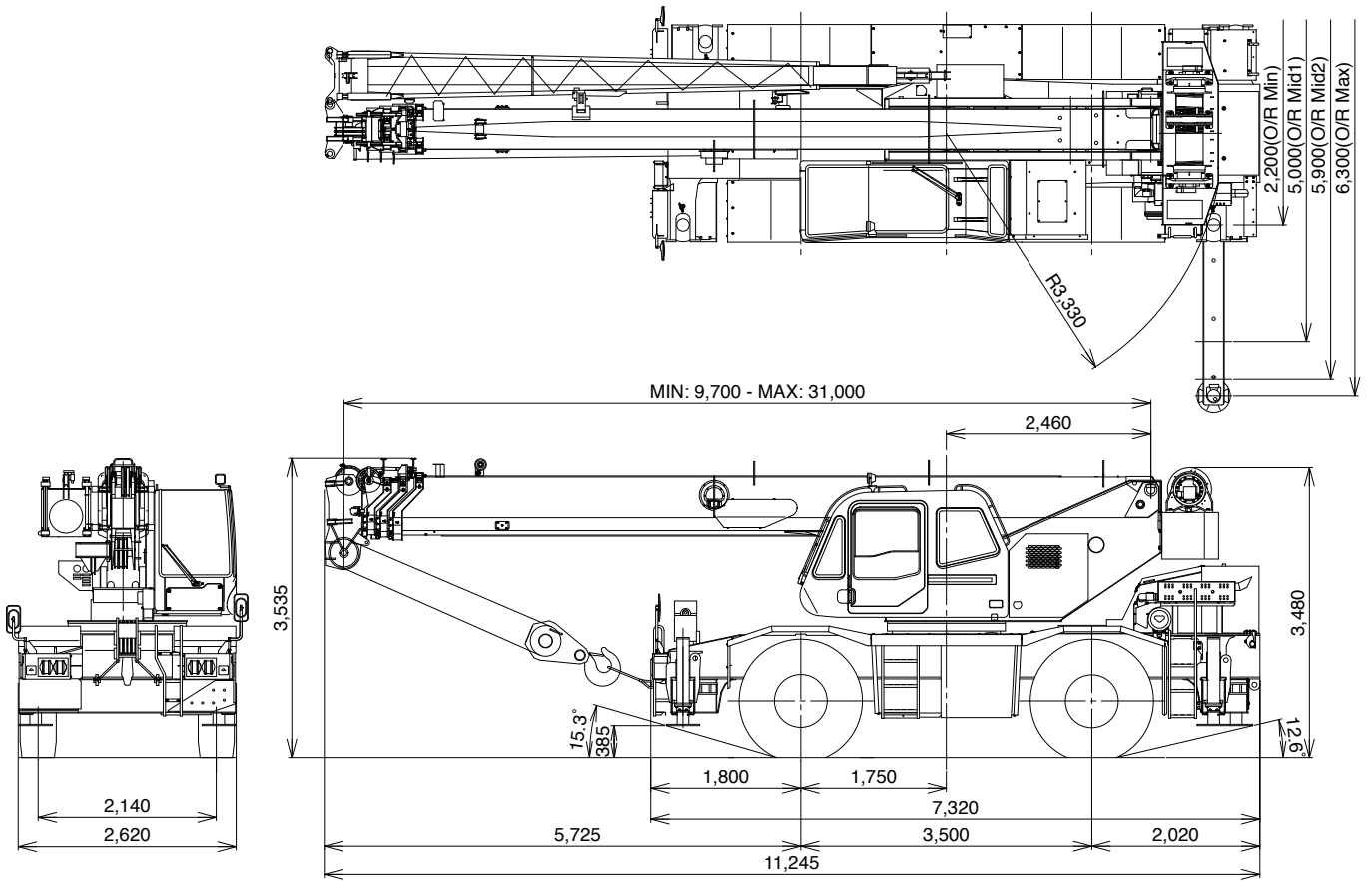

Axle Weight Distribution Chart

Unit : kg

	GVW	Front	Rear
Basic standard machine includes: 4-section boom (9.7 m - 31.0 m) 2-stage jib (7.2 m, 12.8 m) Cummins QSB6.7 Single top 30 ton 4 sheaves hook block 3.9 ton hook block	26,940	13,640	13,300
Add: Air conditioner	+95	+26	+69
Remove: 1. 2-stage jib (7.2 m, 12.8 m) 2. 30 ton 4 sheaves hook block 3. 3.9 ton hook block	-630 -270 -100	-1,085 -480 -140	+455 +210 +40

Specifications are subject to change without notice.



TADANO

TADANO LTD. (International Division)

4-12, Kamezawa 2-chome,
Sumida-ku, Tokyo 130-0014, Japan

Tel : 81-(0)3-3621-7750

Fax : 81-(0)3-3621-7785

 <http://www.tadano.co.jp/indexe.htm>

 tdnihq@tadano.co.jp

Printed in Japan

GR-300EX-2007-02-1