



---

# TG-500E

---

**HYDRAULIC TRUCK CRANE**  
**55-TON CAPACITY (50 METRIC TONS)**

---



# ***Superior strength and enhanced maneuverability***





## "New Truck Crane" Concept

*Safety  
&  
Reliability*

*Excellent  
Performance*

*Easy  
Operation*

### **LEADING IN ITS CLASS**

The TG-500E truck-mounted crane incorporates advanced technology and Tadano's extensive on-the-job know-how to outperform any crane in its class. Both strong and flexible, the TG-500E is tough enough for big jobs, while versatile enough to handle jobs in constricted and irregularly shaped work areas. This power crane features a stronger hexagonal boom, designed for maximum flexural and torsional rigidity and a wider elevation range for close-in lifting. The unit also incorporates a unique feedback system, which provides the operator with information on lifting capacity, load radius, and other operational data for markedly improved operating efficiency.



# Excellent Performance

## Stronger Hexagonal Boom

The advanced design of the TG-500E's hexagonal boom incorporates greatly improved flexural and torsional rigidity for increased strength. The five-section boom, which is operated by a single lever, is equipped with three telescope cylinders and has a range of length from 10.65 to 40.0 meters.

## Single Top (Auxiliary Boom Sheave)

The boom head can be fitted with a single top for light load, high-speed lifting, when extra lift height is not required.



## Extra Reach (extension jib)

A two-stage jib stored under the base boom section can be extended by 9.0 or 14.6 meters and, when erected, can be offset either 5°, 25°, or 45° from the main boom center line. This innovative feature makes lifting at close quarters safe and efficient.



## Narrow space for jib extension

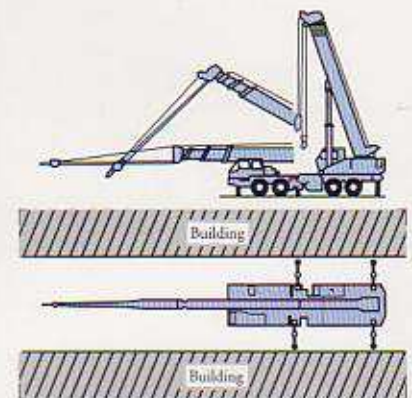

## Underslung Jib

The underslung jib can be quickly and easily extended and stowed within the outrigger width.

# Strength and Stability

## Maximum lifting capacity in restricted areas

The unit's outriggers can be extended to accommodate any work area. Lifting capacities are rated according to each extended position of the outriggers and the actual extension width must coincide with the related information displayed on the AML panel. When the front and rear outrigger extension width differ, the shorter width condition should be set on the AML. If the longer width condition is set, the crane may tip over. Swing does not automatically stop even if the crane becomes overloaded. The swing should be stopped immediately if the moment ratio indication on the AML exceeds 100% and the alarm buzzer sounds during swing into overload.

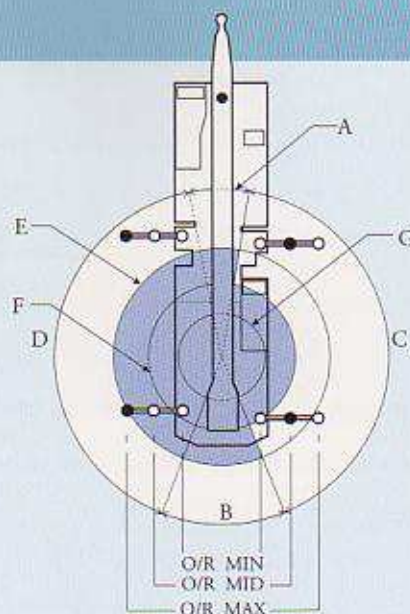

## Maximum lifting capacity in restricted areas

- A: Over-front
- B: Over-rear
- C: Over-side
- D: Over-side
- E: Rated Load (O/R max.6.8m)
- F: Rated Load (O/R mid.4.6m)
- G: Rated Load (O/R min.2.39m)



# Easy Operation

## Crane Control Levers

All crane controls conform to the ISO standards and employ a special spring center system that automatically returns lever positions to neutral when released, thus preventing accidental lever changes during operation. Both easy-to-use foot pedals for telescoping and auxiliary winching improve their operations, when executed simultaneously with parallel-type operation valves. The new system improves overall control and makes it extremely easy to operate crane.



## Easy Single-Lever Operation

Telescoping is done smoothly and easily by operating a single lever, and mode changes can be done without retracting the boom. When extended, the second and third sections are telescoped first. By pressing the fourth and last section switch and moving the telescoping lever forward, the boom is fully extended. When retracted, only the lever needs to be manipulated, while the sections are retracted in reverse order.

# Enhanced Feature

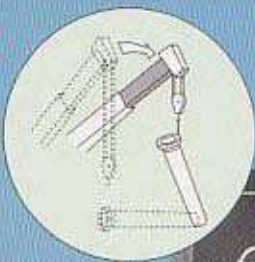

## Twin Swing System

The Twin Swing System is activated by a switch positioned to the left of the operator seat to select either Power Control or Free Swing Control. The Power Control function is suitable for inching operation, while the Free Swing Control is convenient for repeated swing operation. Free swing minimizes shock that occurs when swing is stopped. Winching with the Free Swing Control automatically positions the boom directly over the load's center of gravity. This eliminates potentially dangerous boomhead side-loading and gives the operator maximum control.



## Oil Cooler

The unit's oil cooler prevents power loss due to overheating during prolonged use.

## Adjustable Outriggers

Outriggers mounted on the TG-500E chassis can be extended from a minimum of 2.39 meters, a middle of 4.6 meters and up to a maximum of 6.8 meters to meet the varying requirements of job sites. Equipped with controls and level gauges on either side, the outriggers can be extended simultaneously or independently from either side of the carrier. The outrigger beams can be pinned in retracted or extended positions. Because the floats are attached to the jacks, set up of the outriggers is quick and easy.





# Safety & Reliability

## Automatic Moment Limiter (AML)

Precise and safe operation is ensured by an automatic motion cutting device (AML-LC), which prevents overloading. Information on eight separate functions is continuously displayed on the monitor: total moment, boom angle, actual boom length, actual load radius, extension jib angle, actual hook load, maximum potential load and boom position indicator.

The easy-to-view AML-LC panel displays all the required functions for crane operations. Display changes only while Display Alternation Key (→) is being pressed.

- Four work range limiting function
- Working area limiting function (alarm activates when the boom swings toward the overload area.)
- Displays when Abnormal (Error Code) Buzzer sounds (Error Code is displayed on the Moment display, when a problem occurs with the AML.) Abnormalities and their causes can be easily traced by the Error Code function.

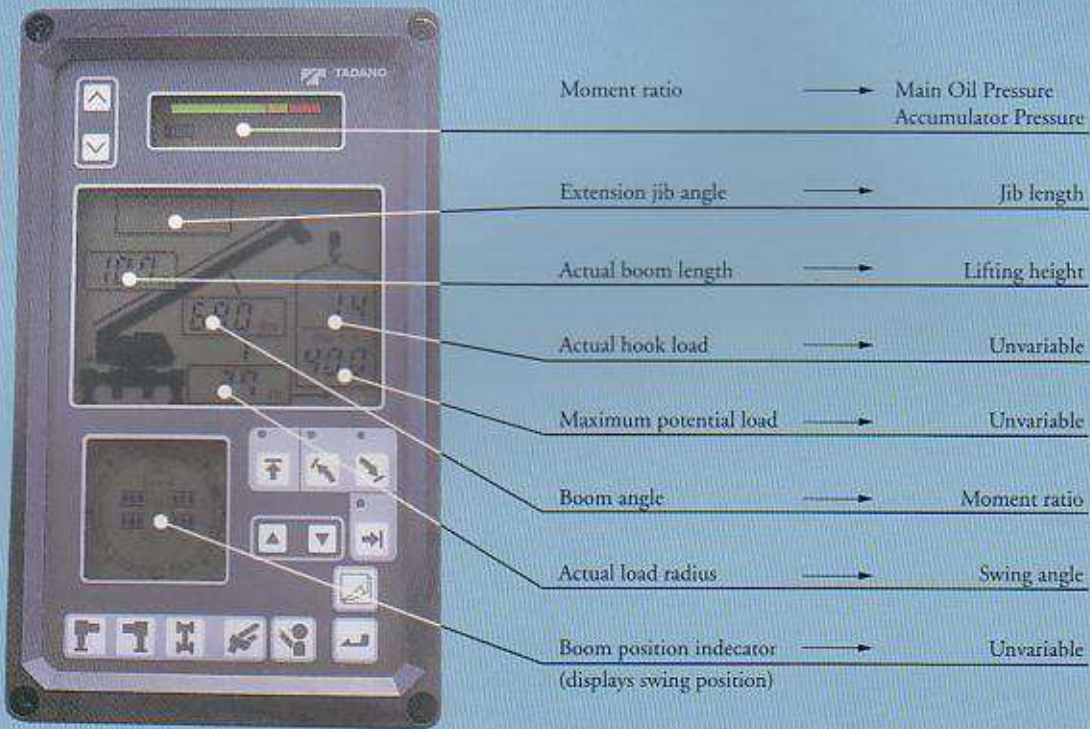

## Working Range Limiting Function

The AML-LC allows the boom to be preset to stop automatically at desired positions during extension and elevation, increasing efficiency and enhancing safety.

The four working range limiting functions can be operated simultaneously.

1. Boom height limiting function
2. Boom elevating angle limiting function
3. Boom lowering angle limiting function
4. Load radius limiting function

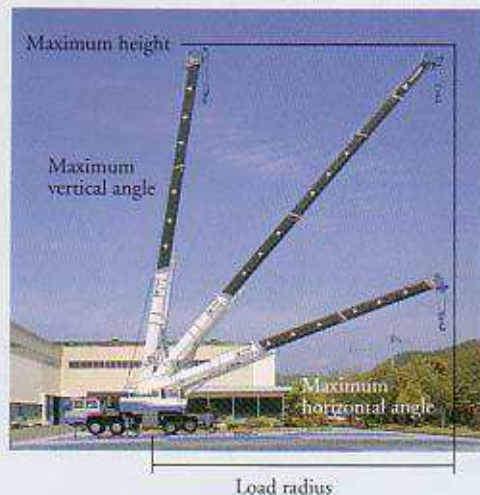

## Improved Safety Features

The outstanding safety features of the TG-500E include:

- Over-winding cutout device
- Cable follower
- Winch drum lock
- Winch drum mirror
- Winch drum rotation indicator
- Front jack overload warning device



# Total Comfort

## Operator Comfort

The wide, all-weather cab is fully ventilated for maximum comfort. Front windshield and roof window wipers are standard equipment. Side and rear windows are unobstructed plate glass, and the roof window is filtered to absorb infrared and ultraviolet light. The cab's sliding door, push-up windows, reclining highback seat, and adjustable control levers have all been designed to optimize comfort and improve operation. The cab's centralized control system makes it possible for the operator to monitor crane conditions at a glance.



## High-Powered Carrier

The TG-500E is equipped with a new, high-powered RF8/250KW(340PS) engine that is designed for sure starting, high power, rapid acceleration and gradability. The transmission features seven forward and one reverse speeds, with synchromesh for second through seventh, ensuring reliable performance.



## Space-Efficient Carrier Cab

The tilting-telescoping steering wheel can be manipulated to accommodate any driving position. All windows are tinted to reduce sun glare. Laminated glass is used in the windshield and armored glass is used in the other windows. The operator's seat cushion is fitted with a special adjustable spring to accommodate the varying weight of operator. The cab is also equipped with AM/FM radio, which features automatic tuning for push-button convenience.