



TR-250EX

Left hand steering

GENERAL DATA

CRANE CAPACITY		25,000 kg at 3.0 m
BOOM		4-section, 8.6 m - 26.9m
DIMENSION		
Overall length	approx.	10,570 mm
Overall width	approx.	2,560 mm
Overall height	approx.	3,450 mm
MASS		
Gross vehicle mass	approx.	24,100 kg
—front axle	approx.	12,250 kg
—rear axle	approx.	11,850 kg
PERFORMANCE		
Max. travelling speed	computed	55 km/h
Gradeability(tan θ)	computed	57 % (at stall)

CRANE SPECIFICATIONS

MODEL

TR-250EX

CAPACITY

25,000 kg at 3.0 m

BOOM

4-section full length power telescoping boom of box construction with 4 sheaves at boom head. 3rd boom and top boom telescope synchronously by means of a double-acting cylinder, an extension cable and a retraction cable.

Hydraulic cylinders fitted with holding valves.

Fully retracted length8.6 m

Fully extended length26.9 m

Extension speed18.3 m in 78 s

JIB

Single staged lattice swingaround boom extension. Stores alongside base boom section.

Triple offset (5°/25°/45°)type. Single sheave at jib head.

Length.....7.5 m

SINGLE TOP (AUXILIARY BOOM SHEAVE)

Single sheave. Mounted to main boom head for single line work.

ELEVATION

By a double-acting hydraulic cylinder, fitted with holding valve.

Elevation speed.....0° to 82° in 42 s

HOIST—Main winch

2-speed type with grooved drum driven by hydraulic axial piston motor through winch speed reducer. Power load lowering and hoisting. Equipped with automatic fail-safe brake and counterbalance valve.

Controlled independently of auxiliary winch.

Single line pull31.4 kN {3,200 kgf}

Single line speed116 m/min (at the 4th layer)

Wire rope.....Spin-resistant type

Diameter x length16 mm x 150 m

TADANO LTD.

HOIST—Auxiliary winch

2-speed type with grooved drum driven by hydraulic axial piston motor through winch speed reducer. Power load lowering and hoisting. Equipped with automatic fail-safe brake and counterbalance valve.

Controlled independently of main winch.

- Single line pull29.4 kN {3,000 kgf}
- Single line speed116 m/min (at the 4th layer)
- Wire ropeSpin-resistant type
- Diameter x length16 mm x 80 m

SWING

Hydraulic axial piston motor driven through planetary swing speed reducer. Continuous 360° full circle swing on ball bearing slew ring. TADANO Twin Swing System to select power-controlled or free swing.

Equipped with manually locked/released swing brake.

- Swing speed3.4 min⁻¹ {rpm}

HYDRAULIC SYSTEM

- PumpsOne variable piston pump and one gear pump for crane.
Tandem gear pump for steering and swing.
- Control valvesMultiple valves actuated by hand levers with integral pressure relief valves.
- CircuitEquipped with air cooled type oil cooler.
- Hydraulic oil tank capacity
approx. 375 liters
- FiltersReturn line filter

CAB

Both crane and drive operations can be performed from one cab mounted on rotating superstructure. One sided one-man type, steel construction with sliding door access and tinted safety glass windows opening at sides, rear and roof. Operator's 3 way adjustable seat with high back and seat belt.

TADANO Automatic Moment Limiter (Model:AML-L)

Main unit in crane cab gives audible and visual warning of approach to overload. Automatically cuts out crane motions before overload. With working range (load radius and/or boom angle and/or tip height) limit function.

Eight functions are constantly displayed.

Digital liquid crystal display:

- Either Boom angle or moment %
- Either boom length or potential hook height
- Either actual load radius or swing angle
- Actual hook load
- Permissible load
- Either jib offset angle or number of parts of line of rope
- Boom position indicator
- Either outrigger position or on-tire indicator

Bar graphical display:

- Either moment as percentage or main hydraulic pressure and torque converter oil pressure (Display changes by alternation key)

OUTRIGGERS

4 hydraulically operated outriggers. Each outrigger controlled simultaneously or independently from the cab. Equipped with sight level gauge. Floats mounted integrally with the jacks retract to within vehicle width. All jack cylinders fitted with pilot check valves.

- Extended width
 - Fully5,800 mm
 - Middle4,500 mm
 - Minimum2,080 mm
- Float size(Diameter)400 mm

COUNTERWEIGHT

Integral with swing frame.

- Mass2,050 kg

NOTE : Each crane motion speed is based on unladen conditions.

TYPE

Rear engine, left hand steering, driving axle 2-way selected type (by manual switch).

- 4 x 2 front drive
- 4 x 4 front and rear drive

FRAME

High-tensile steel, all welded box construction.

ENGINE

Model.....MITSUBISHI 6D16-TUA

Type.....4 cycle, turbo charged, 6 cylinder in line, direct injection, water cooled diesel engine.

Piston displacement7,546 cm³

Bore x stroke118 mm x 115 mm

Max. output.....158 kW {215PS} at 2,800min⁻¹ {rpm}

Max. torque706 N·m {72 kgf·m} at 1,250min⁻¹ {rpm}

TRANSMISSION

Full automatic transmission.

Torque converter (with automatic lock up device at forward 2nd and 3rd) driving full powershift. 6 forward (3 for high range and 3 for low range) and 2 reverse (high range and low range) speeds, constant-mesh.

AXLES

Front.....Full floating type, steering and driving axle with planetary reduction.

Rear.....Full floating type, steering and driving axle with planetary reduction.
Non-spin differential.

STEERING

Hydraulic power steering controlled by steering wheel.

Three steering modes available:

- 2-wheel front
- 4-wheel coordinated
- 4-wheel crab

SUSPENSION

FrontSemi-elliptic leaf springs with hydraulic lockout device.

Rear.....Semi-elliptic leaf springs with hydraulic lockout device.

BRAKE SYSTEM

ServiceAir over hydraulic disc brakes on all 4 wheels.

Parking / Emergency.....

Spring applied-air released brake acting on input shaft of front axle.

Auxiliary.....Electro-pneumatic operated exhaust brake.

ELECTRIC SYSTEM

24 V DC. 2 batteries of 12 V - 120 Ah capacity.

FUEL TANK CAPACITY

250 liters

TIRES

Front16.00 x 25-24PR(OR), Single x 2

Rear.....16.00 x 25-24PR(OR), Single x 2

TURN RADIUS

Min. turning radius(at center of extreme outer tire)

2-wheel steering 9.2 m

4-wheel steering 5.6 m

EQUIPMENT

STANDARD EQUIPMENTS

Automatic moment limiter (AML-L)

External lamp (AML)

Pendant type over-winding cutout

Winch automatic fail-safe brake

25 t capacity hook block (4 sheaves)

3 t capacity hook block (swivel hook)

Hook safety latch

Pilot check valves

Holding valves

Counterbalance valves

Hydraulic pressure relief valves

Swing brake

Swing lock

Boom angle indicator

Boom elevation foot pedal

Boom telescoping foot pedal

Sight level gauge

Electric windshield wiper and washer

Roof window wiper

Roof window unlock warning

Cloth covered cab seat

Tachometer/Speedometer

Cab floor mat

Sun visor (Front and roof)

Neutral position adjustable control lever (swing and/or auxiliary winch)

Automatic drive system

Transmission neutral position engine start

Overshift prevention

Parking braked travel warning

Tilt-telescope steering wheel

Back-up alarm

Air cleaner dust indicator

Air dryer

Water separator with filter

Engine over-run alarm

Hydraulic lockout suspension

Non-spin differential (Rear)

Towing eyes - front and rear

Seat belt (Driver's seat)

Hydraulic oil cooler

OPTIONAL EQUIPMENTS

Drum rotation indicator for main and auxiliary winch (Visual)

Cable follower

Tire inflation kit

Cab cooler

Cab heater and defroster (Diesel engine fuel oil)

Electric fan

Emergency steering

Reversing steering compensator

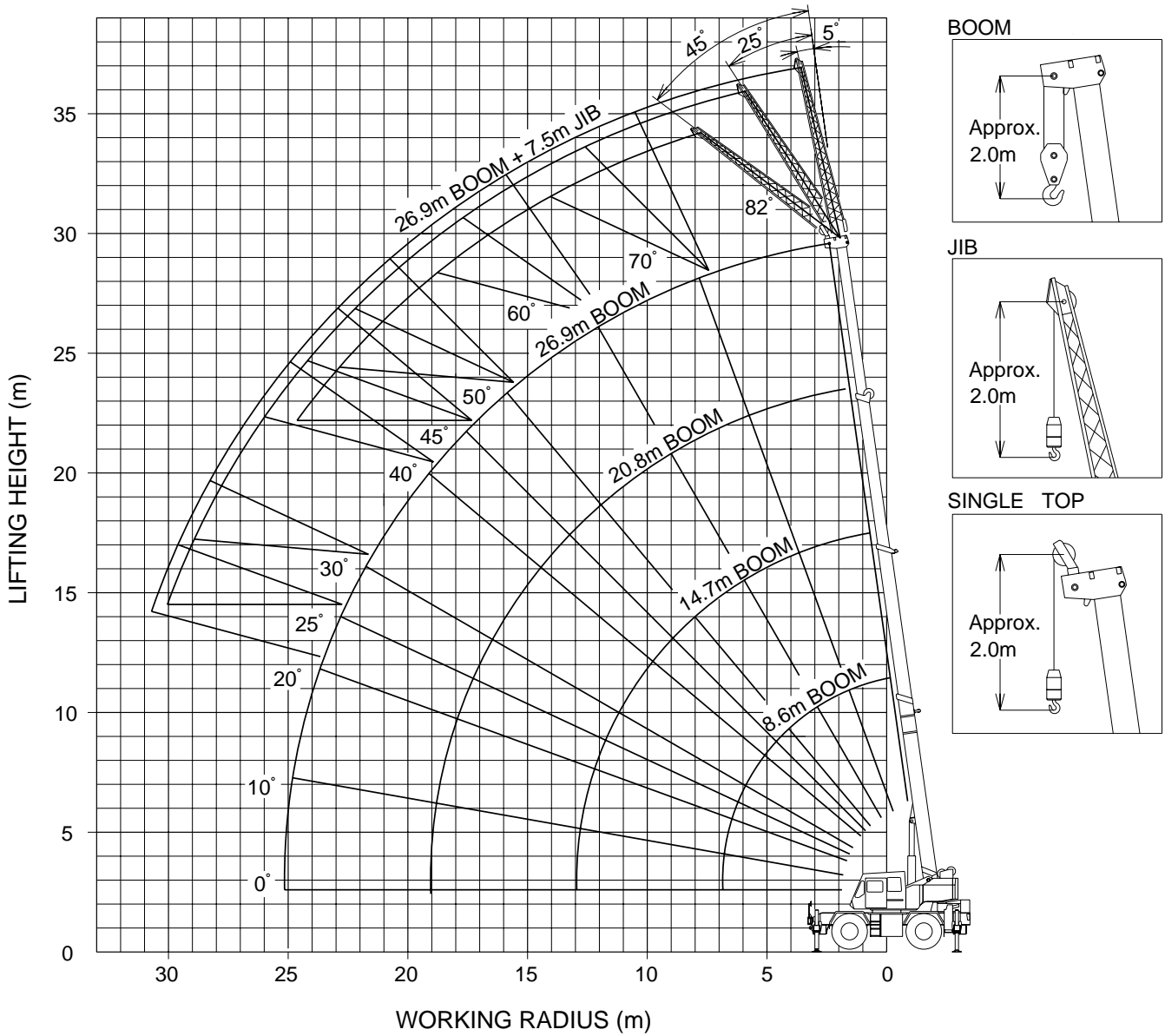

NOTE : The above lifting heights and boom angles are based on a straight (unladen) boom, and allowance should be made for boom deflection obtained under laden conditions.

ON OUTRIGGERS

Unit : kg

Outriggers fully extended (5.8 m) 360° Rotation											
B \ A	8.6	14.7	20.8	26.9	C	26.9 m Boom + 7.5 m Jib					
						5° offset		25° offset		45° offset	
						B	W	B	W	B	W
3.0	25,000	16,500			80° □	6.1	3,000	8.2	2,000	10.3	1,500
3.5	20,000	16,500	10,000		75° □	9.5	3,000	11.3	2,000	13.2	1,500
4.0	18,500	16,500	10,000	7,000	70° □	12.6	2,850	14.3	2,000	16.0	1,400
4.5	16,500	15,100	10,000	7,000	65° □	15.3	2,350	16.9	1,800	18.4	1,300
5.0	15,000	14,000	10,000	7,000	60° □	17.9	1,950	19.4	1,600	20.8	1,250
5.5	13,700	13,000	10,000	7,000	55° □	20.3	1,700	21.7	1,400	22.9	1,200
6.0	12,500	12,000	9,600	7,000	50° □	22.5	1,350	23.8	1,250	24.8	1,150
6.5	11,500	11,200	9,200	7,000	45° □	24.5	1,000	25.6	900	26.3	800
7.0		10,000	8,700	7,000	40° □	26.3	800	27.3	700		
8.0		8,000	7,800	6,700	35° □	28.0	650	28.7	550		
9.0		6,500	7,000	6,250	30° □	29.4	500	29.9	400		
10.0		5,450	5,700	5,600	25° □	30.6	400	30.9	300		
11.0		4,550	4,800	5,000	20° □	31.5	300				
12.0		3,800	4,150	4,300							
13.0			3,600	3,750							
14.0			3,150	3,300							
15.0			2,750	2,900							
16.0			2,400	2,550							
17.0			2,100	2,300							
18.0			1,850	2,100							
19.0			1,550	1,800							
20.0				1,650							
22.0				1,350							
24.0				1,000							
25.0				900							

Unit : kg

Outriggers middle extended (4.5 m) Over side											
B \ A	8.6	14.7	20.8	26.9	C	26.9 m Boom + 7.5 m Jib					
						5° offset		25° offset		45° offset	
						B	W	B	W	B	W
3.0	25,000	16,500			80° □	6.1	3,000	8.2	2,000	10.3	1,500
3.5	20,000	16,500	10,000		75° □	9.5	3,000	11.3	2,000	13.2	1,500
4.0	18,500	16,500	10,000	7,000	70° □	12.6	2,850	14.3	2,000	16.0	1,400
4.5	16,500	15,100	10,000	7,000	65° □	15.2	2,000	16.9	1,700	18.4	1,300
5.0	13,700	13,000	10,000	7,000	60° □	17.6	1,350	19.2	1,200	20.7	1,100
5.5	11,500	10,900	10,000	7,000	55° □	19.9	900	21.4	800	22.6	750
6.0	9,800	9,300	9,600	7,000	50° □	22.1	600	23.4	1500	24.4	500
6.5	8,450	8,050	8,850	7,000							
7.0		7,000	7,750	7,000							
8.0		5,500	6,050	6,450							
9.0		4,350	4,900	5,250							
10.0		3,500	4,050	4,350							
11.0		2,850	3,350	3,650							
12.0		2,300	2,750	3,050							
13.0			2,250	2,550							
14.0			1,850	2,150							
15.0			1,550	1,800							
16.0			1,300	1,550							
17.0			1,050	1,300							
18.0			850	1,050							
19.0			700	900							
20.0				700							

A : Boom length (m)
 B : Load radius (m)
 C : Boom angle
 W : Rated lifting capacity

ON OUTRIGGERS

Unit : kg

Outriggers extended to minimum(2.08 m)				
Over side				
A \ B	8.6	14.7	20.8	26.9
3.0	10,200	9,800		
3.5	8,000	7,650	8,500	
4.0	6,500	6,150	6,900	7,000
4.5	5,350	5,050	5,700	5,950
5.0	4,450	4,150	4,800	5,100
5.5	3,750	3,500	4,050	4,350
6.0	3,200	2,900	3,500	3,750
6.5	2,700	2,450	3,000	3,250
7.0		2,050	2,600	2,850
8.0		1,400	1,900	2,150
9.0		900	1,350	1,600
10.0			950	1,150
11.0				850

A : Boom length (m)

B : Load radius (m)

NOTES FOR "ON OUTRIGGERS" TABLE

- Rated lifting capacities shown in the table are based on condition that crane is set on firm level surface. Those above bold lines are based on crane strength and those below, on its stability.
- Rated lifting capacities based on crane stability are according to ISO4305.
- The mass of the hook (270 kg for 25 t capacity, 100 kg for 3 t capacity), slings and all similarly used load handling devices must be added to the weight of the load.
- For rated lifting capacity of single top, reduce 270 kg from the relevant boom rated lifting capacity. Rated lifting capacity of single top should not exceed 3,000 kg.
- Standard number of parts of line for outrigger operation should be according to the following table. Load per line should not surpass 31.4 kN {3,200 kgf} for main winch and 29.4 kN {3,000 kgf} for auxiliary winch. The lifting capacity data stored in the AUTOMATIC MOMENT LIMITER(AML-L) is based on the standard number of parts of line listed in the chart. Maximum lifting capacity is restricted by the number of parts of line of AUTOMATIC MOMENT LIMITER(AML-L).
- The over-side rated lifting capacity depends on outrigger

Boom length (m)	8.6	8.6 to 14.7	14.7 to 26.9	Jib/Single top
No. of part lines	8	6	4	1

extension. Rated lifting capacity of over-front and over-rear assume fully extended outrigger position. Working area for each outrigger position are given separately and must be followed accordingly during operation.

Outrigger position	Middle	Minimum
Angle	a°	5°

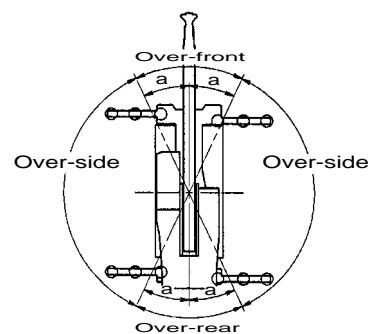

ON TIRES

Unit : kg

A \ B	Stationary						A \ B	Creep					
	Over front			360° □				Over front			360° □		
	8.6	14.7	20.8	8.6	14.7	20.8		8.6	14.7	20.8	8.6	14.7	20.8
3.0	15,000	10,000		9,200	8,000		3.0	11,000	8,000		7,000	5,200	
3.5	13,500	10,000	7,000	7,200	7,000	6,000	3.5	10,500	8,000	6,000	6,200	5,200	3,800
4.0	11,000	10,000	7,000	6,000	5,600	5,000	4.0	9,500	8,000	6,000	5,100	4,700	3,800
4.5	9,100	8,300	7,000	4,900	4,500	4,500	4.5	8,000	7,200	6,000	4,100	3,800	3,800
5.0	8,000	7,200	6,500	4,000	3,700	4,100	5.0	6,900	6,200	6,000	3,300	3,100	3,300
5.5	6,900	6,400	6,000	3,400	3,200	3,500	5.5	5,900	5,500	5,200	2,700	2,600	2,800
6.0	6,100	5,700	5,400	2,800	2,700	3,000	6.0	5,200	4,900	4,700	2,400	2,200	2,400
6.5	5,200	4,900	4,900	2,400	2,300	2,600	6.5	4,500	4,200	4,200	2,000	1,800	2,100
7.0		4,400	4,500		1,900	2,300	7.0		3,700	3,800		1,600	1,800
8.0		3,400	3,700		1,300	1,700	8.0		2,800	3,200		1,000	1,400
9.0		2,600	3,000			1,300	9.0		2,200	2,500			1,000
10.0		2,100	2,500				10.0		1,700	2,000			
11.0		1,700	2,000				11.0		1,400	1,700			
12.0		1,300	1,700				12.0		1,100	1,400			
13.0			1,400				13.0			1,100			
14.0			1,100										

A : Boom length (m)
B : Load radius (m)

WORKING AREA

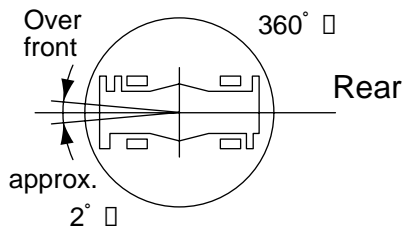

Without outriggers "Over front" operation should be performed within 2 degrees in front of chassis.

NOTES FOR "ON TIRES" TABLE

- Rated lifting capacities shown in the table are based on condition that crane is set on firm level surface, with suspension lock applied. Those above bold lines are based on tire capacity and those below, on crane stability. They are based on actual working radii increased by tire deformation and boom deflection.
- Rated lifting capacities based on crane stability are according to ISO4305.
- The mass of the hook (270 kg for 25 t capacity, 100 kg for 3 t capacity), slings and all similarly used load handling devices must be added to the weight of the load.
- For rated lifting capacity of single top, reduce 270 kg from the relevant boom rated lifting capacity. Rated lifting capacity of single top should not exceed 3,000 kg.
- Without outriggers lifting with "jib" is not permitted. Maximum permissible boom length is 20.8 m.
- CREEP is motion for crane not to travel more than 60 m in any 30 min. period and to travel at the speed of less than 1.6 km/h.
- During "CREEP" duties travel slowly and keep the lifting

- load as close to the ground as possible, and especially avoid any abrupt steering, accelerating or braking.
- Do not operate the crane while carrying the load.
- Tires should be inflated to their correct air pressure of 675 kPa {6.75 kgf/cm²}: 16.00-25-24PR.
- Standard number of parts of line for on tires operation should be according to the following table.
The lifting capacity data stored in the AUTOMATIC MOMENT LIMITER(AML-L) is based on the standard number of parts of line listed in the chart. Maximum lifting capacity is restricted by the number of parts of line of AUTOMATIC MOMENT LIMITER(AML-L).

Boom Length(m)	8.6	8.6 to 20.8	Single top
No. of parts of line	6	4	1

DIMENSION

SPEC. SHEET No. TR-250E-3-00102/EX-23

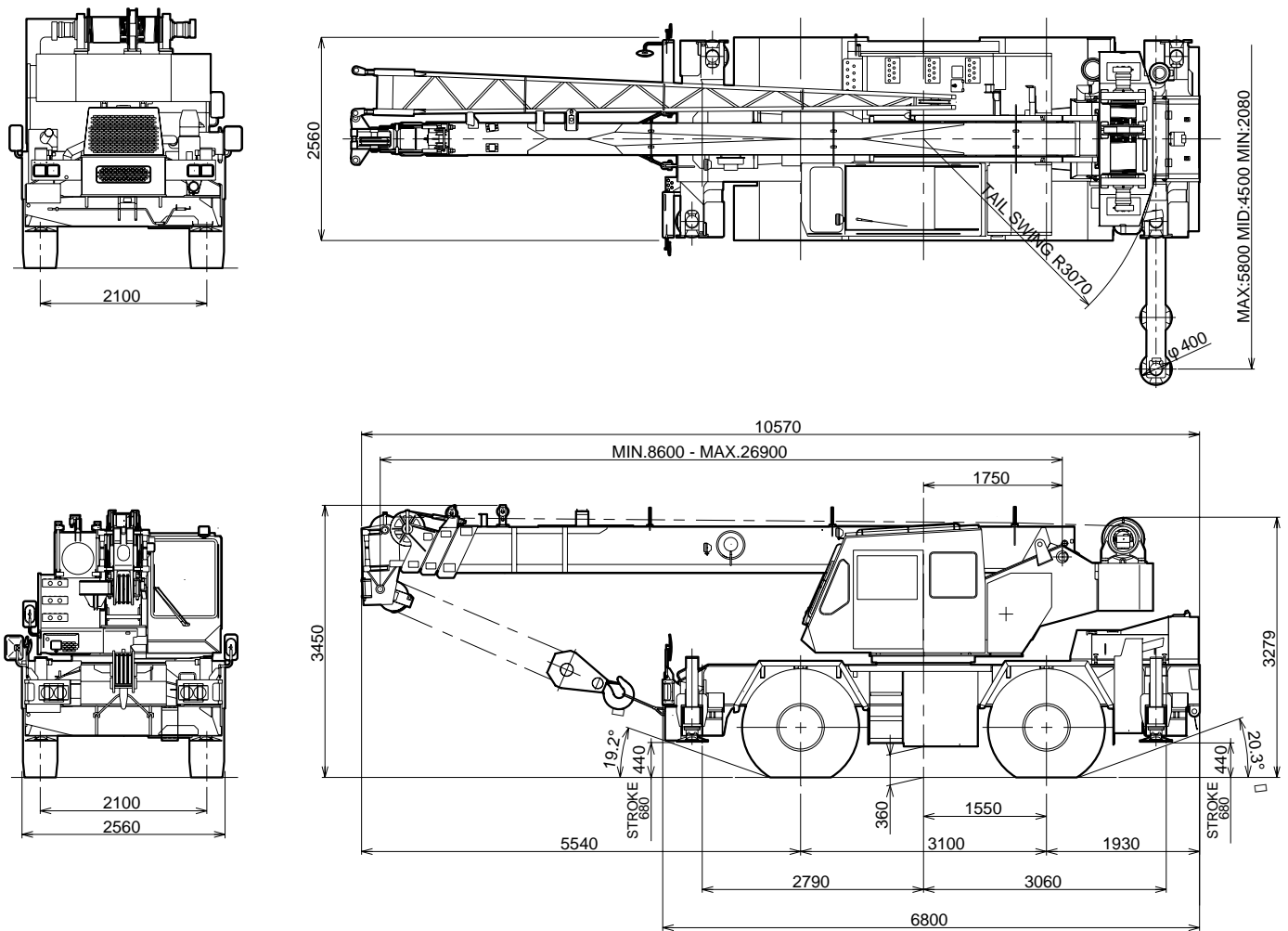

Specifications are subject to change without notice.



TADANO LTD.

4-12, Kamezawa 2-chome,
Sumida-ku, Tokyo 130-0014, Japan

Tel : 81-(0)3-3621-7750

Fax : 81-(0)3-3621-7785

URL <http://www.tadano.co.jp/indexe.htm>

E-mail tdnihq@tadano.co.jp

Printed in Japan

TR-250EX-2003-10-500-1