

ROUGH TERRAIN CRANE

TR-500M

JAPANESE SPECIFICATIONS

TR

OUTLINE	SPEC. NO.
6-section Boom, 2-staged Power Tilt Jib H-type Outrigger	TR-500M-3-00113

Control No. JA-02

TR-500M

CRANE SPECIFICATIONS

CRANE CAPACITY

9.7m Boom	50,000kg	at 3.0m	(12part-line)
16.0m Boom	30,000kg	at 4.5m	(8part-line)
22.3m Boom	20,000kg	at 5.0m	(5part-line)
28.6m Boom	12,000kg	at 8.0m	(4part-line)
34.9m Boom	11,000kg	at 7.0m	(4part-line)
38.05m Boom	8,500kg	at 9.0m	(4part-line)
41.2m Boom	7,000kg	at 10.0m	(4part-line)
7.8m Jib	3,500kg	at 76°	(1part-line)
12.5m Jib	2,500kg	at 76°	(1part-line)
Single top	4,000kg		(1part-line)

MAX.LIFTING HEIGHT

Boom	41.6m
Jib	54.6m

MAX.WORKING RADIUS

Boom	34.0m
Jib	38.1m

BOOM LENGTH

9.7m – 41.2m

BOOM EXTENSION

31.5m

BOOM EXTENSION SPEED

31.5m/122s

JIB LENGTH

7.8m, 12.5m

MAIN WINCH SINGLE LINE WINDING SPEED

124m/min (5th layer)

MAIN WINCH HOOK SPEED

10.3m/min (12 part-line)

AUXILIARY WINCH SINGLE LINE WINDING SPEED

124m/min (5th layer)

AUXILIARY WINCH HOOK SPEED

124m/min (1 part-line)

BOOM ELEVATION ANGLE

0° – 83°

BOOM ELEVATION SPEED

0° – 83°/65s

SWING ANGLE

360° continue

SWING SPEED

2.1rpm

WIRE ROPE

Main Winch

18mm x 224m (Diameter x Length)
Spin-resistant wire rope

Auxiliary Winch

18mm x 120m (Diameter x Length)
Spin-resistant wire rope

BOOM

6-section hydraulically telescoping boom of hexagonal box construction
(stages 2,3: synchronized; stages 4,5,6: synchronized)

BOOM EXTENSION

3 double-acting hydraulic cylinders
2 wire rope type telescoping devices

JIB

Quick-turn type (2-staged type which stores alongside below the base boom section and extendible from under the boom (with 2nd stage being a pull-out type))
Hydraulic non-stage offset (5° – 45°) type

SINGLE TOP

Single sheave. Mounted on main boom head for single line work.

HOIST

Driven by hydraulic motor and via bevel gear reducer.
With free-fall device.
Automatic brake (with foot brake for free-fall device)
2 single winches
With flow regulator valve with pressure compensation

BOOM ELEVATION

2 double-acting hydraulic cylinders
With flow regulator valve with pressure compensation

SWING

Hydraulic motor driven planetary gear reducer
Swing bearing
High/Low speed selection
Swing free/lock changeover type
Negative brake

OUTRIGGERS

Fully hydraulic H-type (floats mounted integrally)
Slides and jacks each provided with independent operation device.
Fully extended width 7.3m
Middle extended width 6.7m, 5.5m, 4.0m
Minimum extended width 2.54m

OPERATION METHOD

Hydraulic pilot valve operation

MAX. VERTICAL LOAD CAPACITY OF OUTRIGGER

38.8t

POWER TAKE-OFF

PTO wet multi-plate clutch

HYDRAULIC PUMPS

2 variable piston pumps
2 gear pumps

HYDRAULIC OIL TANK CAPACITY

570 liters

SAFETY DEVICES

Automatic moment limiter(AML)
Multi-display indication
Swing automatic stop device
Over-winding cutout device
Working area control device
Free-fall interlock device
Outrigger extension width detector
Winch drum lock
Level gauge
Hook safety latch
Hydraulic safety valve
Telescopic counterbalance valve
Elevation counterbalance valve
Power tilt counterbalance valve
Jack pilot check valve
Swing lock

EQUIPMENT

Air-conditioner with dehumidifier
Hydraulic oil temperature indication lamp
Radio
Oil cooler
Visual-type winch drum rotation indicator
Operation pedals
ISO arrangement: for telescoping/auxiliary hoisting
TADANO arrangement: for elevating/telescoping
Television (option)

CARRIER SPECIFICATIONS

ENGINE

Model NISSAN PF6T
(with turbo charger)
Type 4-cycle, 6-cylinder, direct-injection, water-cooled
diesel engine
Piston displacement 12,503cc
Max. output 257kW (350PS) at 2,100rpm
Max. torque 1,334N·m (136kgf·m) at 1,400rpm

TORQUE CONVERTER

3-element, 1-stage unit (with automatic lock-up
mechanism)

TRANSMISSION

Automatic and manual transmission
Power shift type (wet multi-plate clutch)
4 forward and 1 reverse speeds (with Hi/Low settings)

REDUCER

Axle dual-ratio reduction

DRIVE

2-wheel drive (4X2) / 4-wheel drive (4X4) selection

FRONT AXLE

Full floating type

REAR AXLE

Full floating type

SUSPENSION

Front

Hydro-pneumatic suspension (with hydraulic lock cylinder)

Rear

Hydro-pneumatic suspension (with hydraulic lock cylinder)

STEERING

Fully hydraulic power steering
With reverse steering correction mechanism

BRAKE SYSTEM

Service Brake

Hydro-pneumatic brake disk brake

Parking Brake

Mechanically operated, internal expanding duo-servo
shoe type acting on drum at transmission case rear.

Auxiliary Brake

Flow type retarder

Electro-pneumatic operated exhaust brake

Auxiliary braking device for operations

FRAME

Welded box-shaped structure

ELECTRIC SYSTEM

24 V DC. 2 batteries of 12V (120Ah)

FUEL TANK CAPACITY

300 liters

TIRES

Front 505/95R25 183E ROAD

Rear 505/95R25 183E ROAD

CAB

One-man type

With interior equipment

Liquid filled rubber mounted type

Fully adjustable foldable seat

(with headrest and seat belt)

Adjustable handle (tilt, telescoping)

Intermittent type windshield/roof wiper (with washer)

Power window

Side visor

SAFETY DEVICES

Emergency steering device

Suspension lock device

Rear wheel steering lock device

Engine over-run alarm

Overshift prevention device

Parking brake alarm

Powered mirror for right side of boom

Monitor TV for left side of boom

EQUIPMENT

Centralized oiling device

GENERAL DATA

DIMENSIONS

Overall length	11,850mm
Overall width	2,960mm
Overall height	3,710mm
Wheel base	4,850mm
Tread Front	2,380mm
Rear	2,380mm

WEIGHTS

Gross vehicle weight	
Total	37,795kg
Front	18,895kg
Rear	18,900kg

PERFORMANCE

Max. traveling speed	49km/h
Gradeability (tan θ)	0.57
Min. turning radius	6.3m (4-wheel steering) 10.8m (2-wheel steering)

Note:

This crane is covered by Class D Conditions under the
Basic Running Conditions of the Road Traffic Act.

TOTAL RATED LOADS

(1) With outriggers set
[BOOM]

Unit:ton

Outriggers fully extended (7.3m) -360°-							
B \ A	9.7m	16.0m	22.3m	28.6m	34.9m	38.05m	41.2m
2.5m	50.0	30.0	20.0	12.0			
3.0m	50.0	30.0	20.0	12.0			
3.5m	45.0	30.0	20.0	12.0	11.0		
4.0m	39.5	30.0	20.0	12.0	11.0	8.5	
4.5m	35.5	30.0	20.0	12.0	11.0	8.5	
5.0m	32.0	29.0	20.0	12.0	11.0	8.5	7.0
5.5m	29.0	27.0	19.8	12.0	11.0	8.5	7.0
6.0m	26.5	24.6	18.7	12.0	11.0	8.5	7.0
6.5m	24.0	22.7	17.6	12.0	11.0	8.5	7.0
7.0m	22.0	20.9	16.7	12.0	11.0	8.5	7.0
8.0m		17.8	15.0	12.0	10.1	8.5	7.0
9.0m		14.6	13.4	11.5	9.4	8.5	7.0
10.0m		12.0	11.3	10.5	8.7	7.9	7.0
11.0m		10.0	9.4	9.5	8.1	7.35	6.5
12.0m		8.3	8.0	8.6	7.5	6.85	6.0
13.0m		7.1	6.8	7.4	7.0	6.4	5.6
14.0m			5.9	6.6	6.5	6.0	5.3
16.0m			4.2	5.0	5.4	5.3	4.7
18.0m			3.0	3.8	4.3	4.5	4.15
20.0m				2.95	3.4	3.55	3.6
22.0m				2.3	2.7	2.85	3.0
24.0m				1.65	2.1	2.3	2.4
26.0m					1.65	1.85	1.95
28.0m					1.25	1.4	1.55
30.0m					0.9	1.0	1.2
32.0m						0.7	0.9
34.0m							0.6
a (°)	0 ~ 83					16 ~ 83	27 ~ 83
F	50t hook			25t hook			

A= Boom length B= Working radius F= Standard hook
a= Boom angle range (for the unladen condition)

[BOOM]

Unit:ton

Outriggers middle extended (6.7m) –Over sides–							
A \ B	9.7m	16.0m	22.3m	28.6m	34.9m	38.05m	41.2m
2.5m	50.0	30.0	20.0	12.0			
3.0m	50.0	30.0	20.0	12.0			
3.5m	43.0	30.0	20.0	12.0	11.0		
4.0m	38.0	30.0	20.0	12.0	11.0	8.5	
4.5m	34.0	30.0	20.0	12.0	11.0	8.5	
5.0m	30.5	29.0	20.0	12.0	11.0	8.5	7.0
5.5m	27.5	27.0	19.8	12.0	11.0	8.5	7.0
6.0m	24.2	24.0	18.7	12.0	11.0	8.5	7.0
6.5m	21.4	21.2	17.6	12.0	11.0	8.5	7.0
7.0m	19.0	18.9	16.7	12.0	11.0	8.5	7.0
8.0m		15.7	15.0	12.0	10.1	8.5	7.0
9.0m		12.8	12.3	11.5	9.4	8.5	7.0
10.0m		10.4	9.9	10.5	8.7	7.9	7.0
11.0m		8.5	8.2	9.1	8.1	7.35	6.5
12.0m		7.1	6.85	7.75	7.5	6.85	6.0
13.0m		6.1	5.7	6.7	7.0	6.4	5.6
14.0m			4.8	5.8	6.3	6.0	5.3
16.0m			3.4	4.3	4.8	5.0	4.7
18.0m			2.3	3.2	3.75	3.9	4.0
20.0m				2.35	2.9	3.1	3.25
22.0m				1.7	2.2	2.4	2.6
24.0m				1.2	1.65	1.8	2.0
26.0m					1.2	1.4	1.55
28.0m					0.8	1.0	1.1
30.0m					0.5	0.7	0.8
32.0m							0.5
a (°)	0 ~ 83				23 ~ 83	27 ~ 83	36 ~ 83
F	50t hook			25t hook			

A= Boom length B= Working radius F= Standard hook
a= Boom angle range (for the unladen condition)

[BOOM]

Unit:ton

Outriggers middle extended (5.5m) –Over sides–							
A \ B	9.7m	16.0m	22.3m	28.6m	34.9m	38.05m	41.2m
2.5m	45.0	30.0	20.0	12.0			
3.0m	45.0	30.0	20.0	12.0			
3.5m	41.0	30.0	20.0	12.0	11.0		
4.0m	36.8	30.0	20.0	12.0	11.0	8.5	
4.5m	33.2	30.0	20.0	12.0	11.0	8.5	
5.0m	30.2	27.0	20.0	12.0	11.0	8.5	7.0
5.5m	25.2	24.0	19.8	12.0	11.0	8.5	7.0
6.0m	21.0	20.7	18.7	12.0	11.0	8.5	7.0
6.5m	18.2	18.0	17.0	12.0	11.0	8.5	7.0
7.0m	15.5	15.2	15.1	12.0	11.0	8.5	7.0
8.0m		11.9	11.6	12.0	10.1	8.5	7.0
9.0m		9.5	9.15	10.2	9.4	8.5	7.0
10.0m		7.65	7.35	8.35	8.4	7.9	7.0
11.0m		6.25	6.0	7.0	7.3	7.35	6.5
12.0m		5.15	4.9	5.85	6.3	6.3	6.0
13.0m		4.2	4.0	5.0	5.5	5.5	5.6
14.0m			3.25	4.2	4.75	4.8	5.0
16.0m			2.05	3.0	3.55	3.6	3.8
18.0m			1.05	2.1	2.65	2.7	2.9
20.0m				1.35	1.95	2.05	2.25
22.0m				0.7	1.3	1.5	1.7
24.0m					0.8	1.0	1.2
26.0m						0.6	0.8
a (°)	0 ~ 83			24 ~ 83	37 ~ 83	44 ~ 83	49 ~ 83
F	50t hook			25t hook			

A= Boom length B= Working radius F= Standard hook
a= Boom angle range (for the unladen condition)

[BOOM]

Unit:ton

Outriggers middle extended (4.0m) -Over sides-							
A \ B	9.7m	16.0m	22.3m	28.6m	34.9m	38.05m	41.2m
2.5m	40.0	30.0	20.0	12.0			
3.0m	40.0	30.0	20.0	12.0			
3.5m	33.4	30.0	20.0	12.0	11.0		
4.0m	26.5	27.0	20.0	12.0	11.0	8.5	
4.5m	21.0	21.5	20.0	12.0	11.0	8.5	
5.0m	17.4	17.4	17.0	12.0	11.0	8.5	7.0
5.5m	14.6	14.5	14.2	12.0	11.0	8.5	7.0
6.0m	12.5	12.2	12.0	12.0	11.0	8.5	7.0
6.5m	10.5	10.5	10.4	11.3	10.3	8.5	7.0
7.0m	9.0	9.1	9.0	10.0	9.5	8.5	7.0
8.0m		6.9	6.8	7.8	8.0	8.0	7.0
9.0m		5.4	5.25	6.2	6.65	6.7	6.5
10.0m		4.3	4.1	5.0	5.6	5.7	5.9
11.0m		3.4	3.15	4.05	4.65	4.75	5.0
12.0m		2.6	2.45	3.3	3.85	4.0	4.2
13.0m		1.85	1.75	2.7	3.2	3.35	3.55
14.0m			1.15	2.15	2.65	2.85	3.0
16.0m				1.2	1.8	1.95	2.1
18.0m					1.1	1.3	1.45
20.0m						0.75	0.95
a (°)	0 ~ 83		38 ~ 83	47 ~ 83	53 ~ 83	56 ~ 83	59 ~ 83
F	50t hook			25t hook			

A= Boom length B= Working radius F= Standard hook
a= Boom angle range (for the unladen condition)

[BOOM]

Unit: ton

Outriggers minimum extended (2.54m) –Over sides–							
A B	9.7m	16.0m	22.3m	28.6m	34.9m	38.05m	41.2m
2.5m	15.0	11.0	11.0	7.0			
3.0m	15.0	11.0	11.0	7.0			
3.5m	15.0	11.0	11.0	7.0	6.0		
4.0m	13.8	11.0	11.0	7.0	6.0	5.5	
4.5m	11.8	10.5	10.4	7.0	6.0	5.5	
5.0m	9.3	8.8	8.55	7.0	6.0	5.5	5.0
5.5m	7.7	7.3	7.15	6.5	6.0	5.5	5.0
6.0m	6.5	6.1	6.0	5.8	5.5	5.3	5.0
6.5m	5.5	5.2	5.0	5.1	5.0	5.0	5.0
7.0m	4.6	4.4	4.2	4.5	4.5	4.5	4.5
8.0m		3.2	3.0	3.5	3.6	3.7	3.8
9.0m		2.3	2.05	2.5	2.8	2.9	3.1
10.0m		1.5	1.35	1.8	2.1	2.3	2.5
11.0m		0.8					
a (°)	0 ~ 83	34 ~ 83	56 ~ 83	66 ~ 83	71 ~ 83	73 ~ 83	74 ~ 83
F	50t hook			25t hook			

A= Boom length B= Working radius F= Standard hook
a= Boom angle range (for the unladen condition)

[JIB]

Unit:ton

Outriggers fully extended (7.3m) -360°-												
C	7.8m						12.5m					
	5° □		25° □		45° □		5° □		25° □		45° □	
E (°)	B(m)	M	B(m)	M	B(m)	M	B(m)	M	B(m)	M	B(m)	M
83	5.7	3.5	8.2	2.4	10.0	1.6	7.2	2.5	11.2	1.4	13.9	0.8
76	12.8	3.5	14.8	2.4	16.0	1.6	14.9	2.5	18.4	1.4	20.7	0.8
74	14.6	3.25	16.4	2.2	17.6	1.5	16.7	2.25	20.1	1.4	22.2	0.8
72	16.2	2.95	18.0	2.1	19.1	1.48	18.5	2.05	21.7	1.3	23.8	0.8
70	17.8	2.65	19.6	1.95	20.7	1.45	20.3	1.9	23.4	1.25	25.2	0.8
68	19.4	2.4	21.1	1.85	22.2	1.43	22.0	1.75	25.0	1.2	26.7	0.8
65	21.6	2.1	23.5	1.7	24.4	1.4	24.6	1.55	27.4	1.1	29.0	0.77
60	25.3	1.7	27.0	1.45	27.8	1.3	28.5	1.3	31.1	0.95	32.3	0.74
55	28.7	1.2	30.2	1.1	30.7	1.0	32.2	1.0	34.6	0.85	35.5	0.72
50	31.7	0.65	33.0	0.55	33.3	0.5	35.3	0.5	37.5	0.43	38.1	0.4
a (°)	49 ~ 83											

Unit:ton

Outriggers middle extended (6.7m) -Over sides-												
C	7.8m						12.5m					
	5° □		25° □		45° □		5° □		25° □		45° □	
E (°)	B(m)	M	B(m)	M	B(m)	M	B(m)	M	B(m)	M	B(m)	M
83	5.7	3.5	8.2	2.4	10.0	1.6	7.2	2.5	11.2	1.4	13.9	0.8
76	12.8	3.5	14.8	2.4	16.0	1.6	14.9	2.5	18.4	1.4	20.7	0.8
74	14.6	3.25	16.4	2.2	17.6	1.5	16.7	2.25	20.1	1.4	22.2	0.8
72	16.2	2.95	18.0	2.1	19.1	1.48	18.5	2.05	21.7	1.3	23.8	0.8
70	17.8	2.65	19.6	1.95	20.7	1.45	20.3	1.9	23.4	1.25	25.2	0.8
68	19.4	2.4	21.1	1.85	22.2	1.43	22.0	1.75	25.0	1.2	26.7	0.8
65	21.6	2.1	23.5	1.7	24.4	1.4	24.6	1.55	27.4	1.1	29.0	0.77
60	25.3	1.6	27.0	1.45	27.8	1.3	28.5	1.3	31.1	0.95	32.3	0.74
55	28.4	0.9	30.0	0.8	30.6	0.75	31.9	0.75	34.4	0.65	35.4	0.55
53	29.7	0.65	31.1	0.6	31.6	0.55	33.3	0.55	35.6	0.5	36.4	0.4
a (°)	52 ~ 83											

B= Working radius C= Jib length D= Jib offset
 E= Boom angle M= Total rated loads
 a= Boom angle range (for the unladen condition)

[JIB]

Unit:ton

Outriggers middle extended (5.5m) –Over sides–												
C	7.8m						12.5m					
	5° □		25° □		45° □		5° □		25° □		45° □	
E (°)	B(m)	M	B(m)	M	B(m)	M	B(m)	M	B(m)	M	B(m)	M
83	5.7	3.5	8.2	2.4	10.0	1.6	7.2	2.5	11.2	1.4	13.9	0.8
76	12.8	3.5	14.8	2.4	16.0	1.6	14.9	2.5	18.4	1.4	20.7	0.8
74	14.6	3.25	16.4	2.2	17.6	1.5	16.7	2.25	20.1	1.4	22.2	0.8
72	16.2	2.95	18.0	2.1	19.1	1.48	18.5	2.05	21.7	1.3	23.8	0.8
70	17.8	2.65	19.6	1.95	20.7	1.45	20.3	1.9	23.4	1.25	25.2	0.8
68	19.4	2.3	21.1	1.85	22.2	1.43	22.0	1.75	25.0	1.2	26.7	0.8
65	21.4	1.65	23.3	1.45	24.3	1.25	24.4	1.4	27.4	1.1	29.0	0.77
62	23.4	1.1	25.2	0.95	26.1	0.8	26.4	0.85	29.4	0.7	31.0	0.65
a (°)	61 ~ 83											

Unit:ton

Outriggers minimum extended (4.0m) –Over sides–												
C	7.8m						12.5m					
	5° □		25° □		45° □		5° □		25° □		45° □	
E (°)	B(m)	M	B(m)	M	B(m)	M	B(m)	M	B(m)	M	B(m)	M
83	5.7	3.5	8.2	2.4	10.0	1.6	7.2	2.5	11.2	1.4	13.9	0.8
76	12.8	3.5	14.8	2.4	16.0	1.6	14.9	2.5	18.4	1.4	20.7	0.8
74	14.2	2.6	16.4	2.2	17.6	1.5	16.7	2.1	20.1	1.4	22.2	0.8
72	15.7	2.0	17.7	1.7	19.1	1.45	18.0	1.6	21.7	1.3	23.8	0.8
70	17.1	1.5	19.3	1.25	20.5	1.1						
a (°)	69 ~ 83						71 ~ 83					

B= Working radius C= Jib length D= Jib offset
 E= Boom angle M= Total rated loads
 a= Boom angle range (for the unladen condition)

PRECAUTIONS TO BE TAKEN WHEN THE OUTRIGGERS ARE EXTENDED:

1. The total rated loads shown are for the case where the crane is set horizontally on firm level ground. They include the weights of the slings and hooks (50t hook: 460kg, 25t hook: 300kg, auxiliary hook: 100kg).
The values above the bold lines are based on the crane strength while those below are based on the crane stability.
2. Since the total rated loads are based on the actual working radii including the deflection of the boom, operations should be performed in accordance with the working radii.
3. Jib operations should be performed in accordance with the boom angle, irrespective of the boom length. The working radii are reference values for the case where the jib is mounted to a 41.2m boom.
4. The total rated load for the single top shall be the value obtained by subtracting the weight of the hook mounted to the boom from the total rated load of the boom and must not exceed 4.0t.
5. As a rule, free-fall operation should be performed only when lowering the hook alone. If a hoisted load must be lowered by free-fall operation, the load must be kept below 1/5th of the total rated load and sudden braking operations must be avoided.
6. The table below shows the standard number of part lines for each boom length. The load per line should not exceed 40.9kN(4.17t) for the main winch and 39.2kN (4.0t) for the auxiliary winch.

A	9.7m	16.0m	22.3m	28.6m	34.9m	38.05m	41.2m	Single top
H	12	8	6	4	4	4	4	1

A= Boom length H= No. of part-lines

7. The hoisting performance for the "Over sides" range will differ according to the extended width of the outriggers. Operations should be performed in accordance with the performance corresponding to the extended width. Also, although the hoisting performances for the "Over front" and "Over rear" ranges are equivalent to those of the "outriggers fully extended" condition, the front and rear ranges (angle a) will differ according to the width to which the outriggers are extended in the left and right directions.

Extended width	Middle extended (6.7m)	Middle extended (5.5m)	Middle extended (4.0m)	Minimum extended (2.54m)
Angle a° □	30	25	15	5

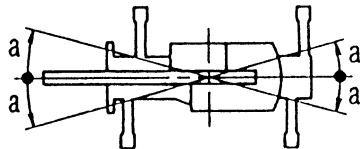

(2) Without outriggers

Unit:ton

B (m)	Stationary						Creep (travelling at 1.6km/h or less)						
	9.7m Boom		16.0m Boom		22.3m Boom		9.7m Boom		16.0m Boom		22.3m Boom		
	K	G	K	G	K	G	K	G	K	G	K	G	
3.0	20.0	12.5	15.0	10.0			14.5	8.0	10.5	6.5			
3.5	20.0	12.5	15.0	10.0			14.5	8.0	10.5	6.5			
4.0	20.0	11.0	15.0	10.0	11.0	5.5	14.5	8.0	10.5	6.5	8.0	4.5	
4.5	18.0	9.0	15.0	8.5	11.0	5.5	12.9	6.8	10.5	6.5	8.0	4.5	
5.0	16.0	7.4	15.0	7.0	11.0	5.5	11.5	5.8	10.5	5.3	8.0	4.5	
5.5	14.3	6.2	14.0	5.7	11.0	5.3	10.3	4.8	10.5	4.4	8.0	4.1	
6.0	12.8	5.2	13.0	4.8	11.0	4.4	9.3	4.0	10.0	3.7	8.0	3.55	
6.5	11.7	4.35	12.0	4.05	10.0	3.7	8.6	3.35	9.3	3.15	8.0	3.05	
7.0	10.8	3.7	11.0	3.4	9.2	3.0	7.9	2.8	8.5	2.7	7.4	2.55	
8.0			9.0	2.3	7.7	2.0			7.0	1.85	6.4	1.65	
9.0			7.0	1.3	6.4	1.15			5.9	1.1	5.4	0.95	
10.0			5.7	0.6	5.4				4.8	0.5	4.5		
11.0			4.7		4.5				3.9		3.7		
12.0			4.0		3.8				3.3		3.1		
13.0			3.4		3.2				2.8		2.6		
14.0					2.7						2.2		
16.0					1.8						1.5		
18.0					1.05						0.85		
a (°)	0~78		40~ 78		24~ 78	61~ 78	0~78			40~ 78		24~ 78	61~ 78
F	25t hook						25t hook						

B= Working radius K= Front G= 360° F= Standard hook
a= Boom angle range (for the unladen condition)

PRECAUTIONS TO BE TAKEN WHEN THE OUTRIGGERS ARE NOT MOUNTED:

1. The total rated loads shown are for the case where the tire air pressure on firm level ground is as specified 800kPa (8.00kg/cm²) and the suspension-lock cylinder is retracted as much as possible. They include the weights of the slings and hooks (50t hook: 460kg, 25t hook: 300kg, auxiliary hook: 100kg). The values above the bold lines are based on the crane strength while those below are based on the crane stability. The foundation, working conditions, etc. should be taken into consideration for actual work.
2. Since the working radii are based on the actual values including the deflection of the boom and the tires, operations should be performed in accordance with the working radii.
3. The table below shows the standard number of part lines for each boom length. The load per line should not exceed 40.9kN (4.17t) for the main winch and 39.2kN (4.0t) for the auxiliary winch.

A	9.7m	16.0m	22.3m	Single top
H	6	4	4	1

A= Boom length H= No. of part-lines

4. "Over front" crane operations should be performed only when "Over front" is displayed on the standard display. The boom must be kept inside a 2° area over front of the carrier when performing "Over front" crane operations without the outriggers.

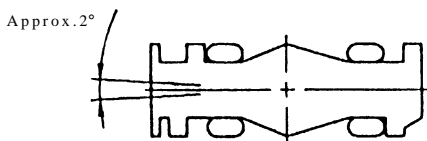

5. The total rated load for the single top shall be the value obtained by subtracting the weight of the hook mounted to the boom from the total rated load of the boom and must not exceed 4.0t.
6. Free-fall operations should not be performed without outriggers. Booms over 22.3m in length and jibs should not be used without outriggers.
7. The "Drive Mode Selection" switch should be set to "4-wheel / Lo" for creeping while hoisting a load and the shift lever should be set first.
8. When creeping while hoisting a load, the swing brake should be applied, the load should be kept as close to the ground as possible but not touching the ground and the speed should be kept at 1.6km/h or less. In particular, any abrupt steering, starting or braking must be avoided.
9. Crane operations should not be performed when creeping while hoisting a load.

WORKING RADIUS - LIFTING HEIGHT

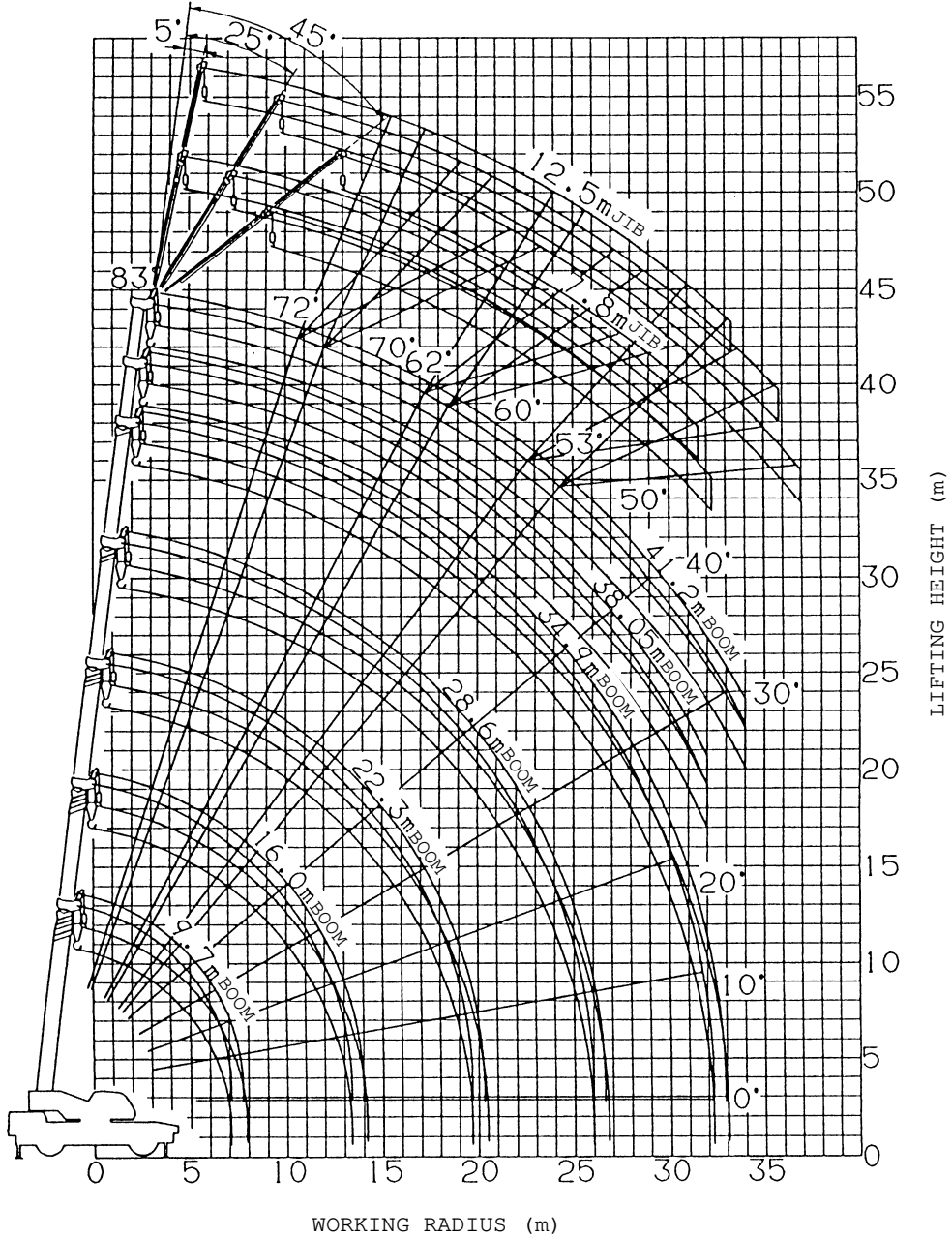

NOTES:

1. The deflection of the boom is not incorporated in the figure above.
2. The figure above is for the case where the outriggers are fully extended (360°).

DIMENSIONS (1/100)

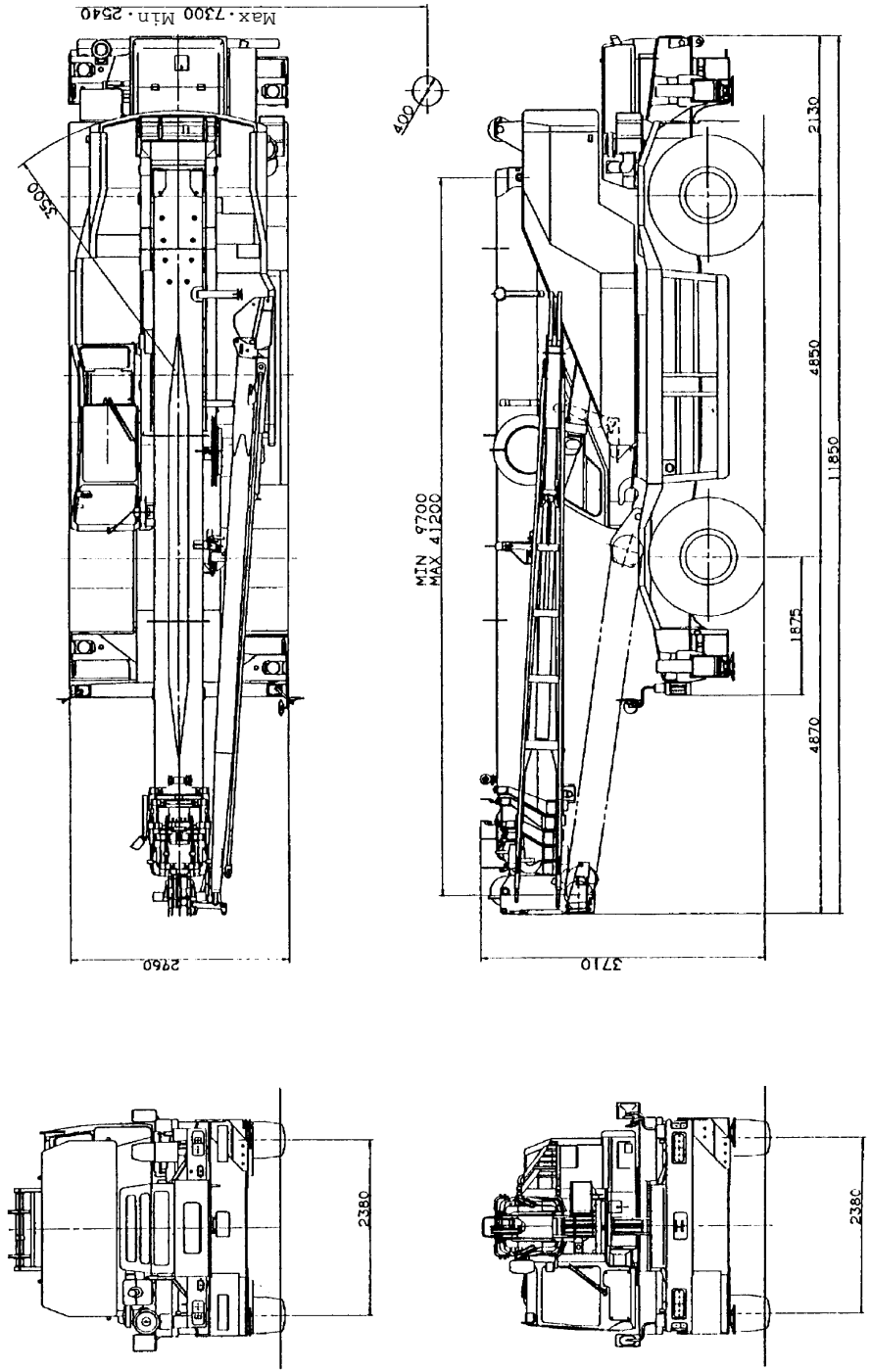

◆ MEMO ◆
