



**ALL TERRAIN CRANE  
AC 100/4L**



120 tons AC capacity class

**DATASHEET IMPERIAL**

# AC 100/4L



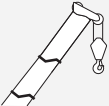

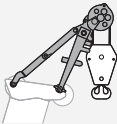
**WORKS FOR YOU.™**

	Page:
<b>Dimensions</b> .....	5
<b>Specifications</b> .....	6
<b>Equipment</b> .....	7
<b>Counterweight</b> .....	8
 <b>HA</b> Main boom .....	9
 <b>HAV</b> Folding swing-away jib .....	15
 <b>HAV-VA</b> Variable extension with swing-away jib .....	21
 <b>MS</b> Runner .....	27
<b>Technical description</b> .....	32

 Counterweight

 Lifting capacities on outriggers · 360°

 Radius

 Main boom

 Swing-away jib

 Runner

 Adapter

 Max. axle loads

 Mechanism

 Tyres

 Hook block

 Hoist

 Dolly

 Travel speed

 Gradeability – road  
%

 Gradeability – off road  
%

 Slewing

 Boom telescoping

 Boom elevation

 Workings speeds

 Max. line pull

 Rope diameter

 Rope length

 Hook block (capacity-sheaves-rope diameter)

 Number of lines

 Possible load of hook block

 Weight of hook block

 Distance head sheave axle – hook ground

 Number of sheaves in boom head

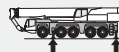
 Supporting force

 Length of stroke (support cylinders)

 Additional parts for hydraulic system

## Features:

- ▶ Highest lifting capacities of any four-axle crane – both with maximum counterweight configuration as well as when remaining inside the 26,500 lb axle load limit
- ▶ With a 194.9 ft telescopic boom and a 32.8 ft folding swing-away jib (= 227.7 ft) this crane disposes of the longest system length that can travel on four axles at 26,500 lb axle load
- ▶ Only four-axle crane in the category above 154,400 lb with a vehicle width of only 8'5" when using 16.00R25-size tyres
- ▶ 11,900 lb counterweight within 26,500 lb axle load, 47,000 lb within 35,300 lb axle load roadable
- ▶ High and economic road and crane performance due to powerful and modern drive train technology
- ▶ Most variable main boom extension system in its class
- ▶ 4 outrigger bases standard

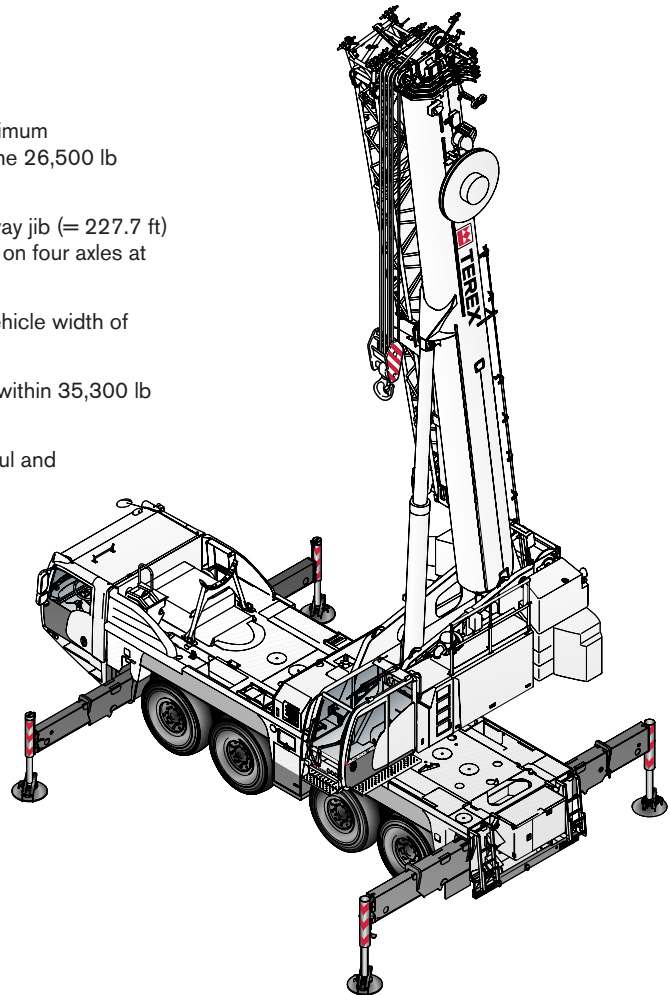

# DIMENSIONS

**AC 100/4L**

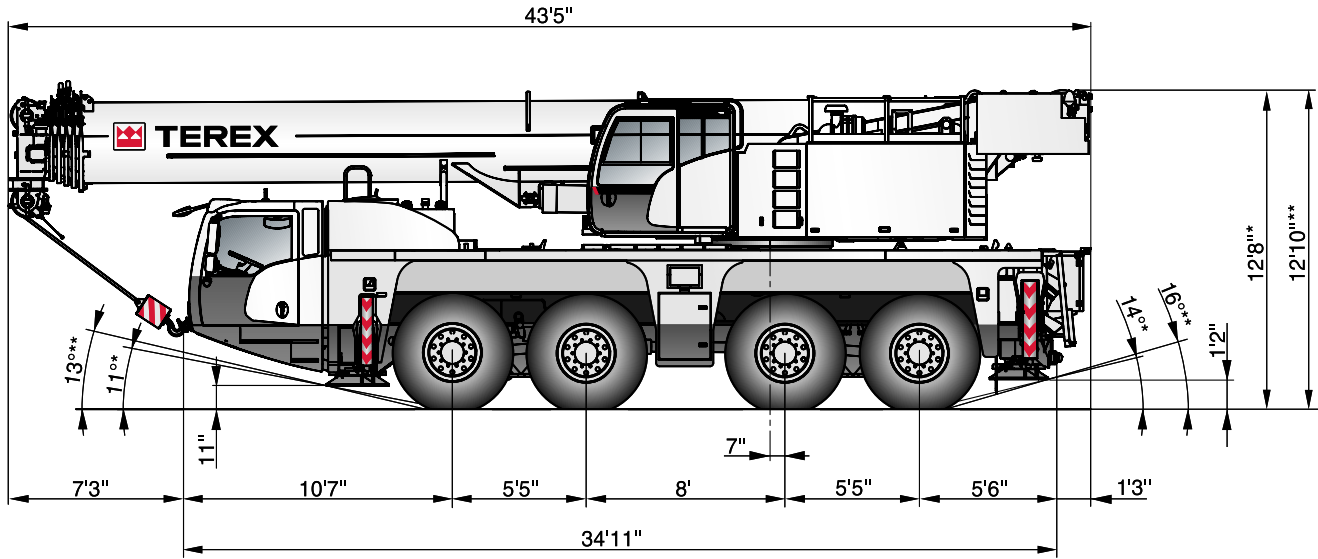

\* Wheels 14"  
\*\* Wheels 16"

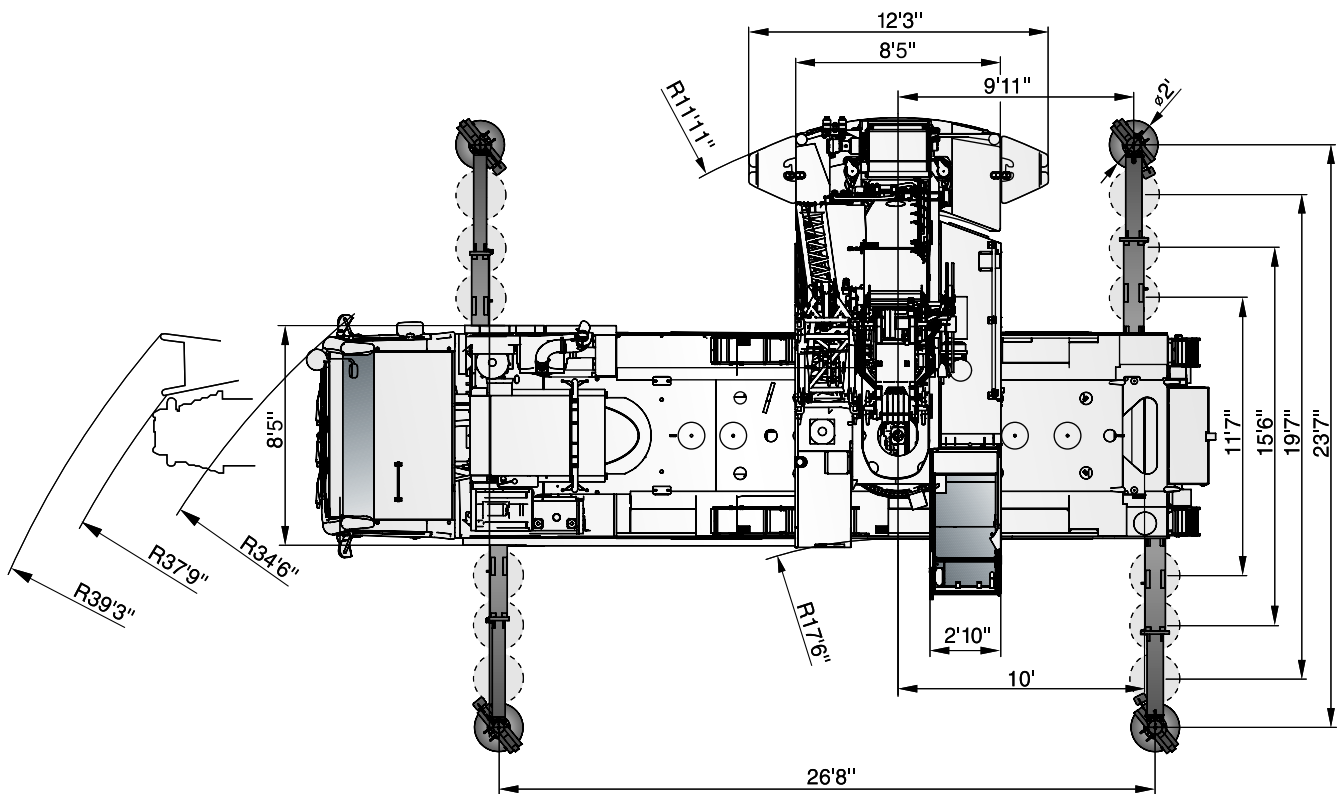

# SPECIFICATIONS

# AC 100/4L

	Total									EuroMot 3a Tier3	EuroMot 3b Tier4i	
< 22,100 lb				On request!						X	X	X
26,500 lb	106,000 lb	8 x 8 x 8	445/95R25	20-1-18	10,400 lb	-	-	-	-	X	X	
26,500 lb	106,000 lb	8 x 8 x 8	525/80R25	20-1-18	10,400 lb	-	-	-	-	X		
26,500 lb	106,000 lb	8 x 6 x 8	385/95R25	-	10,400 lb	32.8 ft	-	-	-	X		
26,500 lb	106,000 lb	8 x 8 x 8	445/95R25	-	11,900 lb	-	-	-	-	X		
28,700 lb	110,250 lb	8 x 8 x 8	445/95R25	20-1-18	11,900 lb	62.3 ft	-	-	-	X	X	
32,000 lb	123,500 lb	8 x 8 x 8	445/95R25	50-3-18	22,300 lb	62.3 ft	-	-	-	X	X	
36,400 lb	145,500 lb	8 x 8 x 8	445/95R25	20-1-18	43,700 lb	62.3 ft hydr.	-	X	-	X	X	
36,400 lb	145,500 lb	8 x 8 x 8	445/95R25	-	47,000 lb	62.3 ft	-	-	-	X	X	

Further configurations on request!

	1 Highway > 28 mph		4* Off-wall
	2 City < 28 mph		5* Crab steer mode
	3* Minimum turning radius < 3 mph		6* All wheel steering

\* must be activated

94,800 lb	134,500 lb	50 mph <sup>1)</sup>
22.4"	25.2"	

<sup>1)</sup> Depending on tire type, size and country specific legislation

	385/95 R25 14.00 R25	445/95 R25 16.00 R25	525/80 R25 20.50 R25
	45 %	40 %	40 %
	> 70 %	> 60 %	> 60 %

1	377.3 ft/min	14,500 lb	0.72"	870 ft
2	377.3 ft/min	14,500 lb	0.72"	870 ft
	1.4 min <sup>-1</sup>			
	395 s (39.4-194.9 ft)			
	60 s (0°-82°)			

1	14.5 kip	8-0-18	5	-	375 lb	3.3 ft
2	29.0 kip	20-1-18	5	-	662 lb	5.9 ft
3	43.6 kip	20-1-18	5	-	662 lb	5.9 ft
4	58.1 kip	50-3-18	5	-	1,210 lb	5.9 ft
5	72.6 kip	50-3-18	5	-	1,210 lb	5.9 ft
6	87.1 kip	50-3-18	5	-	1,210 lb	5.9 ft
7	101.6 kip	50-3-18	5	-	1,210 lb	5.9 ft
8	116.1 kip	80-5-18	5	-	1,430 lb	6.6 ft
9	130.7 kip	80-5-18	5	-	1,430 lb	6.6 ft
10	145.2 kip	80-5-18	5	-	1,430 lb	6.6 ft
11	159.7 kip	80-5-18	5 + S1	-	1,430 lb	6.6 ft
12	174.2 kip	100-7-18	5 + S1	-	1,650 lb	6.6 ft
13	176.4 kip	100-7-18	5 + S1	-	1,650 lb	6.6 ft



# EQUIPMENT

**AC 100/4L**

**HAV / HAV-VA**

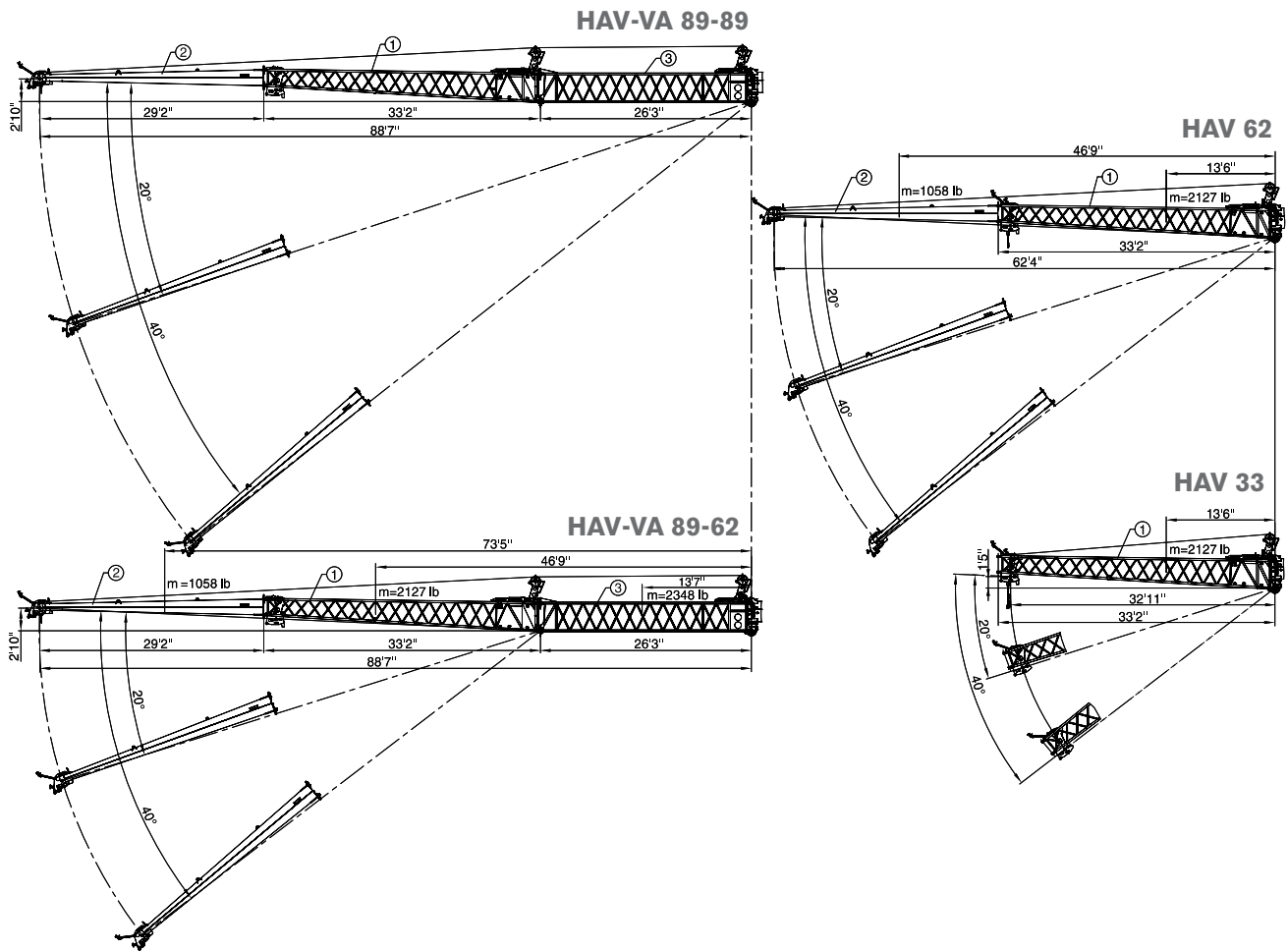

**MS**

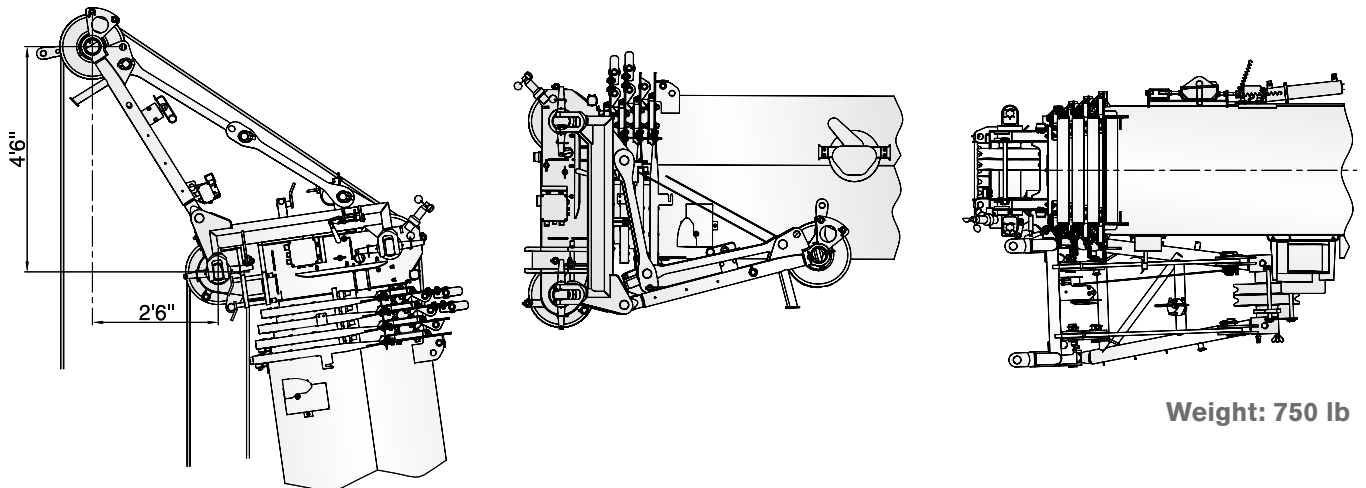

# COUNTERWEIGHT

## AC 100/4L

### Parts

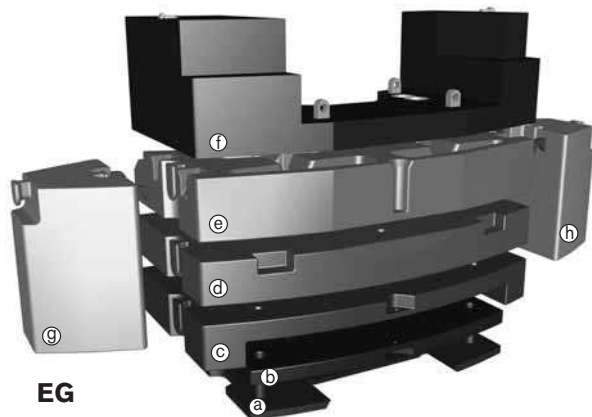

EG

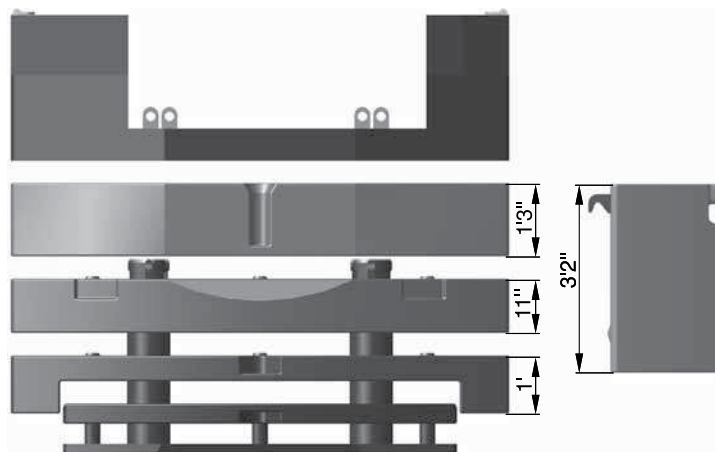

NEG

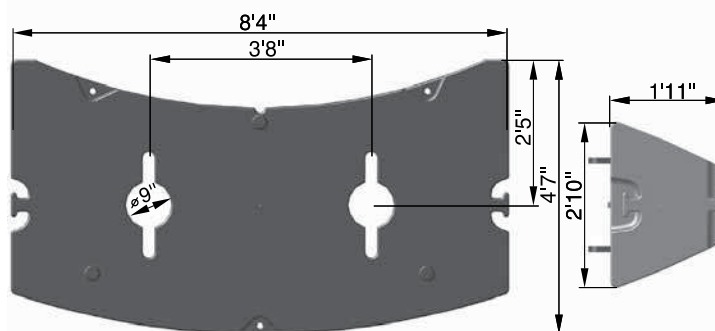

### Configurations



	EG	NEG	(a) 1.5 kip	(b) 3.3 kip	(c) 7.0 kip	(d) 11.5 kip	(e) 13.2 kip	(f) 10.4 kip	(g) 5.3 kip	(h) 5.3 kip	(i) 10.4 kip
1.5 kip	X	X	X								
4.9 kip	X	X	X	X							
8.6 kip	X	X	X		X						
10.4 kip	X							X			
11.9 kip	X		X					X			
11.9 kip	X	X	X	X	X						
15.2 kip	X		X	X				X			
19.0 kip	X		X		X			X			
20.1 kip	X	X	X		X	X					
22.3 kip	X		X	X	X			X			
23.4 kip	X	X	X	X	X	X					
30.4 kip	X		X		X	X		X			
33.3 kip	X	X	X		X	X	X				
33.7 kip	X		X	X	X	X		X			
36.6 kip	X	X	X	X	X	X	X				
43.7 kip	X		X		X	X	X	X			
43.9 kip	X	X	X		X	X	X		X	X	
47.0 kip	X		X	X	X	X	X	X			
47.2 kip	X	X	X	X	X	X	X		X	X	
54.2 kip	X		X		X	X	X	X	X	X	
54.2 kip		X	X		X	X	X		X	X	X
57.5 kip	X		X	X	X	X	X	X	X	X	
57.5 kip		X	X	X	X	X	X		X	X	X



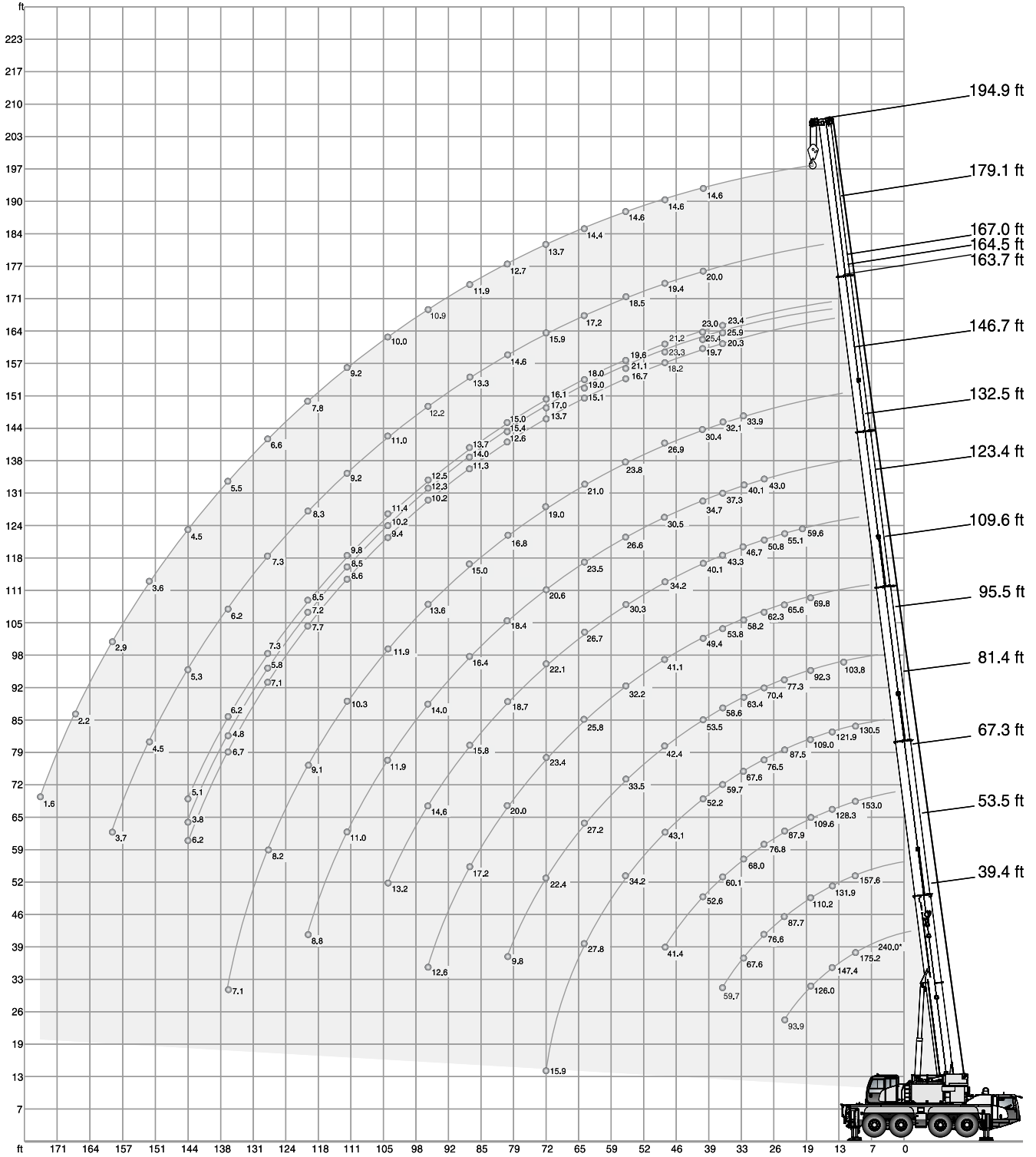
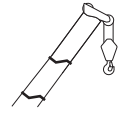



\* Capacity class

57,500 lb		26.6 ft x 23.6 ft														360°		85 %	
																			
(0°)																			
ft		1,000 lb														ft			
ft		39.4	39.4	53.5	67.3	81.4	95.5	109.6	123.4	132.5	146.7	163.7	165.4	167.0	179.1	194.9			
	240.0*	-	-	-	-	-	-	-	-	-	-	-	-	-	-	-	-		
10	175.2	161.4	157.6	153.0	130.5	-	-	-	-	-	-	-	-	-	-	-	-	10	
12	160.3	145.3	144.1	139.7	127.0	-	-	-	-	-	-	-	-	-	-	-	-	12	
14	147.4	131.6	131.9	128.3	121.9	103.8	-	-	-	-	-	-	-	-	-	-	-	14	
16	136.0	119.4	120.1	118.7	116.3	97.8	-	-	-	-	-	-	-	-	-	-	-	16	
18	126.0	109.5	110.2	109.6	109.0	92.3	69.8	-	-	-	-	-	-	-	-	-	-	18	
20	115.9	100.2	101.6	101.0	101.4	86.9	68.4	59.6	-	-	-	-	-	-	-	-	-	20	
24	93.9	85.9	87.7	87.9	87.5	77.3	65.6	55.1	-	-	-	-	-	-	-	-	-	24	
28	-	-	76.6	76.8	76.5	70.4	62.3	50.8	43.0	-	-	-	-	-	-	-	-	28	
32	-	-	67.6	68.0	67.6	63.4	58.2	46.7	40.1	33.9	-	-	-	-	-	-	-	32	
36	-	-	59.7	60.1	59.7	58.6	53.8	43.3	37.3	32.1	20.3	25.9	23.4	-	-	-	-	36	
40	-	-	-	52.6	52.2	53.5	49.4	40.1	34.7	30.4	19.7	25.4	23.0	20.0	14.6	-	-	40	
48	-	-	-	41.4	43.1	42.4	41.1	34.2	30.5	26.9	18.2	23.3	21.2	19.4	14.6	-	-	48	
56	-	-	-	-	34.2	33.5	32.2	30.3	26.6	23.8	16.7	21.1	19.6	18.5	14.6	-	-	56	
64	-	-	-	-	27.8	27.2	25.8	26.7	23.5	21.0	15.1	19.0	18.0	17.2	14.4	-	-	64	
72	-	-	-	-	15.9	22.4	23.4	22.1	20.6	19.0	13.7	17.0	16.1	15.9	13.7	-	-	72	
80	-	-	-	-	-	9.8	20.0	18.7	18.4	16.8	12.6	15.4	15.0	14.6	12.7	-	-	80	
88	-	-	-	-	-	-	17.2	15.8	16.4	15.0	11.3	14.0	13.7	13.3	11.9	-	-	88	
96	-	-	-	-	-	-	12.6	14.6	14.0	13.6	10.2	12.3	12.5	12.2	10.9	-	-	96	
104	-	-	-	-	-	-	-	13.2	11.9	11.9	9.4	10.2	11.4	11.0	10.0	-	-	104	
112	-	-	-	-	-	-	-	-	11.0	10.3	8.6	8.5	9.8	9.2	9.2	-	-	112	
120	-	-	-	-	-	-	-	-	8.8	9.1	7.7	7.2	8.5	8.3	7.8	-	-	120	
128	-	-	-	-	-	-	-	-	-	8.2	7.1	5.8	7.3	7.3	6.6	-	-	128	
136	-	-	-	-	-	-	-	-	-	7.1	6.7	4.8	6.2	6.2	5.5	-	-	136	
144	-	-	-	-	-	-	-	-	-	-	6.2	3.8	5.1	5.3	4.5	-	-	144	
152	-	-	-	-	-	-	-	-	-	-	-	-	-	4.5	3.6	-	-	152	
160	-	-	-	-	-	-	-	-	-	-	-	-	-	3.7	2.9	-	-	160	
168	-	-	-	-	-	-	-	-	-	-	-	-	-	-	2.2	-	-	168	
176	-	-	-	-	-	-	-	-	-	-	-	-	-	-	1.6	-	-	176	

\* Capacity class

		47,000 lb														26.6 ft x 23.6 ft		360°		85 %	
		ft																			
		39.4	53.5	67.3	81.4	95.5	109.6	123.4	132.5	146.7	163.7	165.4	167.0	179.1	194.9						
		1,000 lb																			
ft	ft																				
10	160.9	157.6	153.0	130.5	-	-	-	-	-	-	-	-	-	-	-	-	-	-	10		
12	144.7	144.0	139.7	127.0	-	-	-	-	-	-	-	-	-	-	-	-	-	-	12		
14	130.4	131.1	128.3	121.9	103.8	-	-	-	-	-	-	-	-	-	-	-	-	-	14		
16	118.1	119.0	118.4	116.3	97.8	-	-	-	-	-	-	-	-	-	-	-	-	-	16		
18	108.2	109.1	108.9	108.7	92.3	69.8	-	-	-	-	-	-	-	-	-	-	-	-	18		
20	99.1	100.9	100.9	100.7	86.9	68.4	59.6	-	-	-	-	-	-	-	-	-	-	-	20		
24	85.1	86.8	87.1	86.7	77.3	65.6	55.1	-	-	-	-	-	-	-	-	-	-	-	24		
28	-	75.6	75.9	75.4	70.4	62.3	50.8	43.0	-	-	-	-	-	-	-	-	-	-	28		
32	-	65.2	65.6	64.9	63.3	58.2	46.7	40.1	33.9	-	-	-	-	-	-	-	-	-	32		
36	-	56.4	56.8	56.1	56.9	53.5	43.3	37.3	32.1	20.3	25.9	23.4	-	-	-	-	-	-	36		
40	-	-	48.8	50.8	49.9	48.3	40.1	34.7	30.4	19.7	25.4	23.0	20.0	14.6	-	-	-	-	40		
48	-	-	38.4	38.4	37.5	36.2	33.8	30.5	26.9	18.2	23.3	21.2	19.4	14.6	-	-	-	-	48		
56	-	-	-	30.1	29.5	28.3	28.9	26.2	23.8	16.7	21.1	19.6	18.5	14.6	-	-	-	-	56		
64	-	-	-	24.4	23.7	24.6	23.5	22.2	21.0	15.1	19.0	18.0	17.2	14.4	-	-	-	-	64		
72	-	-	-	15.9	21.2	20.6	19.3	19.7	18.3	13.7	17.0	16.1	15.9	13.7	-	-	-	-	72		
80	-	-	-	-	9.8	17.2	17.1	16.6	16.2	12.6	15.0	15.0	14.6	12.7	-	-	-	-	80		
88	-	-	-	-	-	14.7	15.1	14.0	14.0	11.3	12.2	13.5	12.9	11.9	-	-	-	-	88		
96	-	-	-	-	-	10.3	13.0	12.6	11.8	10.2	10.1	11.5	10.8	10.6	-	-	-	-	96		
104	-	-	-	-	-	-	11.2	11.0	10.5	9.4	8.2	9.5	9.6	8.8	-	-	-	-	104		
112	-	-	-	-	-	-	-	9.4	9.0	8.6	6.5	8.1	8.1	7.4	-	-	-	-	112		
120	-	-	-	-	-	-	-	7.0	7.8	7.7	5.3	6.7	6.8	6.1	-	-	-	-	120		
128	-	-	-	-	-	-	-	-	7.2	6.6	4.2	5.5	5.7	4.8	-	-	-	-	128		
136	-	-	-	-	-	-	-	-	5.5	5.5	3.3	4.6	4.7	3.9	-	-	-	-	136		
144	-	-	-	-	-	-	-	-	-	4.7	2.5	3.8	3.8	3.1	-	-	-	-	144		
152	-	-	-	-	-	-	-	-	-	-	-	-	3.0	2.3	-	-	-	-	152		
160	-	-	-	-	-	-	-	-	-	-	-	-	2.4	-	-	-	-	-	160		

		43,700 lb														26.6 ft x 23.6 ft		360°		85 %	
		ft																			
		39.4	53.5	67.3	81.4	95.5	109.6	123.4	132.5	146.7	163.7	165.4	167.0	179.1	194.9						
		1,000 lb																			
ft	ft																				
10	160.7	157.6	153.0	130.5	-	-	-	-	-	-	-	-	-	-	-	-	-	-	10		
12	144.4	143.9	139.7	127.0	-	-	-	-	-	-	-	-	-	-	-	-	-	-	12		
14	129.9	130.7	128.3	121.9	103.8	-	-	-	-	-	-	-	-	-	-	-	-	-	14		
16	117.8	118.5	118.0	116.3	97.8	-	-	-	-	-	-	-	-	-	-	-	-	-	16		
18	108.0	108.8	108.5	108.5	92.3	69.8	-	-	-	-	-	-	-	-	-	-	-	-	18		
20	98.9	100.5	100.7	100.4	86.9	68.4	59.6	-	-	-	-	-	-	-	-	-	-	-	20		
24	84.7	86.5	86.7	86.2	77.3	65.6	55.1	-	-	-	-	-	-	-	-	-	-	-	24		
28	-	74.9	75.2	74.6	70.4	62.3	50.8	43.0	-	-	-	-	-	-	-	-	-	-	28		
32	-	63.9	64.3	63.8	63.3	58.2	46.7	40.1	33.9	-	-	-	-	-	-	-	-	-	32		
36	-	54.9	55.2	55.0	56.1	52.6	43.3	37.3	32.1	20.3	25.9	23.4	-	-	-	-	-	-	36		
40	-	-	47.4	48.8	48.1	46.6	40.1	34.7	30.4	19.7	25.4	23.0	20.0	14.6	-	-	-	-	40		
48	-	-	37.0	37.0	36.1	34.7	33.4	30.5	26.9	18.2	23.3	21.2	19.4	14.6	-	-	-	-	48		
56	-	-	-	29.0	28.3	28.2	28.0	25.6	23.8	16.7	21.1	19.6	18.5	14.6	-	-	-	-	56		
64	-	-	-	23.5	23.5	23.7	22.4	22.2	20.5	15.1	19.0	18.0	17.2	14.4	-	-	-	-	64		
72	-	-	-	15.9	20.4	19.7	18.8	18.8	17.9	13.7	17.0	16.1	15.9	13.7	-	-	-	-	72		
80	-	-	-	-	9.8	16.6	17.0	15.7	15.7	12.6	14.1	14.9	14.4	12.7	-	-	-	-	80		
88	-	-	-	-	-	14.4	14.5	13.9	13.2	11.3	11.5	12.9	12.2	11.7	-	-	-	-	88		
96	-	-	-	-	-	9.5	12.3	12.3	11.7	10.2	9.4	10.7	10.7	10.1	-	-	-	-	96		
104	-	-	-	-	-	-	10.9	10.4	9.9	9.4	7.5	9.0	9.1	8.4	-	-	-	-	104		
112	-	-	-	-	-	-	-	9.0	8.5	8.5	6.1	7.4	7.6	6.8	-	-	-	-	112		
120	-	-	-	-	-	-	-	6.6	7.7	7.2	4.8	6.1	6.3	5.5	-	-	-	-	120		
128	-	-	-	-	-	-	-	-	6.8	6.2	3.7	5.1	5.2	4.4	-	-	-	-	128		
136	-	-	-	-	-	-	-	-	5.1	5.1	2.8	4.1	4.2	3.5	-	-	-	-	136		
144	-	-	-	-	-	-	-	-	-	4.2	2.0	3.3	3.3	2.7	-	-	-	-	144		
152	-	-	-	-	-	-	-	-	-	-	-	-	-	2.6	-	-	-	-	152		
160	-	-	-	-	-	-	-	-	-	-	-	-	-	2.0	-	-	-	-	160		

33,300 lb		26.6 ft x 23.6 ft														360°		85 %	
ft		39.4	53.5	67.3	81.4	95.5	109.6	123.4	132.5	146.7	163.7	165.4	167.0	179.1	194.9	ft			
1,000 lb																ft			
10	160.2	157.6	153.0	130.5	-	-	-	-	-	-	-	-	-	-	-	-	10		
12	143.1	143.4	139.7	127.0	-	-	-	-	-	-	-	-	-	-	-	-	12		
14	128.7	129.4	128.2	121.9	103.8	-	-	-	-	-	-	-	-	-	-	-	14		
16	116.5	117.4	117.1	116.3	97.8	-	-	-	-	-	-	-	-	-	-	-	16		
18	106.8	107.7	108.0	108.0	92.3	69.8	-	-	-	-	-	-	-	-	-	-	18		
20	97.8	99.6	99.8	99.4	86.9	68.4	59.6	-	-	-	-	-	-	-	-	-	20		
24	82.8	84.9	85.2	84.8	77.1	65.6	55.1	-	-	-	-	-	-	-	-	-	24		
28	-	71.1	71.5	71.0	67.0	62.3	50.8	43.0	-	-	-	-	-	-	-	-	28		
32	-	58.7	59.1	60.1	59.8	55.4	46.7	40.1	33.9	-	-	-	-	-	-	-	32		
36	-	49.0	49.5	51.6	50.7	47.7	42.7	37.3	32.1	20.3	25.9	23.4	-	-	-	-	36		
40	-	-	43.0	42.9	42.1	40.5	38.7	34.6	30.4	19.7	25.4	23.0	20.0	14.6	-	-	40		
48	-	-	32.3	32.2	31.4	31.1	31.2	28.5	26.7	18.2	23.3	21.2	19.4	14.6	-	-	48		
56	-	-	-	25.2	25.6	25.6	24.2	23.7	22.4	16.7	21.1	19.6	18.5	14.6	-	-	56		
64	-	-	-	20.7	21.2	20.5	20.6	19.7	19.4	15.1	18.0	18.0	17.2	14.4	-	-	64		
72	-	-	-	15.9	17.5	17.5	17.3	17.0	16.0	13.7	14.4	15.7	14.8	13.7	-	-	72		
80	-	-	-	-	9.8	15.1	14.4	14.2	13.9	12.6	11.3	12.8	12.5	11.5	-	-	80		
88	-	-	-	-	-	12.8	12.6	11.9	11.5	11.2	9.0	10.5	10.6	9.3	-	-	88		
96	-	-	-	-	-	9.1	10.7	10.1	9.9	9.6	7.1	8.5	8.7	7.7	-	-	96		
104	-	-	-	-	-	-	9.0	8.4	8.6	7.9	5.5	7.0	7.0	6.2	-	-	104		
112	-	-	-	-	-	-	-	7.7	7.2	6.6	4.1	5.7	5.7	5.0	-	-	112		
120	-	-	-	-	-	-	-	4.8	6.1	5.5	3.1	4.4	4.6	3.7	-	-	120		
128	-	-	-	-	-	-	-	-	5.2	4.5	2.1	3.4	3.6	2.8	-	-	128		
136	-	-	-	-	-	-	-	-	3.7	3.7	-	2.6	2.7	1.9	-	-	136		
144	-	-	-	-	-	-	-	-	-	2.9	-	1.8	2.0	-	-	-	144		

22,300 lb		26.6 ft x 23.6 ft														360°		85 %	
ft		39.4	53.5	67.3	81.4	95.5	109.6	123.4	132.5	146.7	163.7	165.4	167.0	179.1	194.9	ft			
1,000 lb																ft			
10	159.1	157.5	153.0	130.5	-	-	-	-	-	-	-	-	-	-	-	-	10		
12	141.5	142.4	139.7	127.0	-	-	-	-	-	-	-	-	-	-	-	-	12		
14	127.3	128.1	127.5	121.9	103.8	-	-	-	-	-	-	-	-	-	-	-	14		
16	115.4	116.2	116.2	115.8	97.8	-	-	-	-	-	-	-	-	-	-	-	16		
18	105.7	106.6	107.5	107.1	92.3	69.8	-	-	-	-	-	-	-	-	-	-	18		
20	96.4	98.2	98.5	97.7	86.5	68.4	59.6	-	-	-	-	-	-	-	-	-	20		
24	77.7	80.5	80.9	77.5	70.5	64.7	55.1	-	-	-	-	-	-	-	-	-	24		
28	-	64.2	64.7	64.1	61.6	56.5	50.8	43.0	-	-	-	-	-	-	-	-	28		
32	-	50.7	53.0	53.4	51.7	47.3	44.3	40.1	33.9	-	-	-	-	-	-	-	32		
36	-	43.1	44.5	44.4	43.5	40.6	38.7	35.6	32.1	20.3	25.9	23.4	-	-	-	-	36		
40	-	-	36.9	36.7	36.0	35.6	35.0	32.0	30.1	19.7	25.4	23.0	20.0	14.6	-	-	40		
48	-	-	27.3	27.3	28.5	27.9	26.4	26.1	24.4	18.2	22.6	21.2	19.4	14.6	-	-	48		
56	-	-	-	22.2	22.2	21.6	21.9	20.8	20.5	16.7	18.2	19.2	17.8	14.6	-	-	56		
64	-	-	-	18.0	17.8	18.2	17.6	17.3	17.0	15.1	14.2	15.8	14.9	13.4	-	-	64		
72	-	-	-	15.0	15.0	14.8	14.6	14.2	13.7	13.7	11.1	12.6	12.2	10.6	-	-	72		
80	-	-	-	-	9.8	12.4	12.2	11.6	11.8	11.1	8.5	10.0	9.8	8.3	-	-	80		
88	-	-	-	-	-	10.3	10.2	10.1	9.7	9.1	6.4	8.0	7.8	6.5	-	-	88		
96	-	-	-	-	-	8.8	8.4	8.6	8.0	7.3	4.7	6.2	6.4	5.0	-	-	96		
104	-	-	-	-	-	-	7.0	7.2	6.6	5.9	3.3	4.8	4.8	3.7	-	-	104		
112	-	-	-	-	-	-	-	5.9	5.2	4.6	-	3.5	3.7	2.6	-	-	112		
120	-	-	-	-	-	-	-	2.9	4.2	3.6	-	2.6	2.7	-	-	-	120		
128	-	-	-	-	-	-	-	-	3.4	2.8	-	-	-	-	-	-	128		
136	-	-	-	-	-	-	-	-	1.9	1.9	-	-	-	-	-	-	136		

15,200 lb		26.6 ft x 23.6 ft														360°		85 %	
ft	ft	39.4	53.5	67.3	81.4	95.5	109.6	123.4	132.5	146.7	163.7	165.4	167.0	179.1	194.9	ft	ft		
		1,000 lb																	
10	158.0	157.4	153.0	130.5	-	-	-	-	-	-	-	-	-	-	-	10	10		
12	140.7	141.4	139.6	127.0	-	-	-	-	-	-	-	-	-	-	-	12	12		
14	126.4	127.3	126.8	121.9	103.8	-	-	-	-	-	-	-	-	-	-	14	14		
16	114.5	115.4	115.9	115.3	97.8	-	-	-	-	-	-	-	-	-	-	16	16		
18	104.0	105.2	106.6	102.7	89.4	69.8	-	-	-	-	-	-	-	-	-	18	18		
20	93.6	96.2	96.7	89.4	80.3	68.2	59.6	-	-	-	-	-	-	-	-	20	20		
24	72.6	75.5	74.9	69.6	67.7	61.6	54.6	-	-	-	-	-	-	-	-	24	24		
28	-	57.4	59.0	59.2	55.4	50.4	46.9	42.5	-	-	-	-	-	-	-	28	28		
32	-	46.3	47.7	47.6	46.2	43.2	40.9	37.0	33.9	-	-	-	-	-	-	32	32		
36	-	38.3	39.6	39.5	38.7	37.5	35.9	32.7	30.2	20.3	25.9	23.4	-	-	-	36	36		
40	-	-	32.8	32.6	32.9	33.2	30.7	29.5	27.7	19.7	25.2	23.0	20.0	14.6	40	40			
48	-	-	24.1	25.5	25.4	24.6	24.7	23.4	22.6	18.2	19.8	20.7	18.9	14.6	48	48			
56	-	-	-	19.9	19.6	19.9	19.4	19.3	18.7	16.7	15.1	16.9	15.8	13.7	56	56			
64	-	-	-	16.0	16.2	15.9	15.8	15.1	14.9	14.3	11.5	13.1	12.6	11.0	64	64			
72	-	-	-	13.1	13.1	12.9	12.6	12.6	12.2	11.3	8.4	10.0	9.8	8.2	72	72			
80	-	-	-	-	9.8	10.7	10.2	10.5	9.8	9.1	6.3	7.9	7.6	6.1	80	80			
88	-	-	-	-	-	8.7	8.3	8.5	7.8	7.2	4.5	6.1	5.8	4.4	88	88			
96	-	-	-	-	-	7.1	6.7	6.9	6.2	5.6	3.1	4.6	4.4	3.1	96	96			
104	-	-	-	-	-	-	5.4	5.6	5.0	4.3	1.9	3.3	3.2	2.1	104	104			
112	-	-	-	-	-	-	-	4.6	3.9	3.2	-	-	2.2	-	112	112			
120	-	-	-	-	-	-	-	-	2.9	2.2	-	-	-	-	120	120			
128	-	-	-	-	-	-	-	-	2.2	-	-	-	-	-	128	128			

11,900 lb		26.6 ft x 23.6 ft														360°		85 %	
ft	ft	39.4	53.5	67.3	81.4	95.5	109.6	123.4	132.5	146.7	163.7	165.4	167.0	179.1	194.9	ft	ft		
		1,000 lb																	
10	157.3	157.4	153.0	130.5	-	-	-	-	-	-	-	-	-	-	-	10	10		
12	140.2	140.9	139.4	127.0	-	-	-	-	-	-	-	-	-	-	-	12	12		
14	126.0	126.7	126.4	121.9	103.8	-	-	-	-	-	-	-	-	-	-	14	14		
16	114.2	114.9	115.5	113.6	97.8	-	-	-	-	-	-	-	-	-	-	16	16		
18	102.8	103.9	104.4	99.3	87.2	69.8	-	-	-	-	-	-	-	-	-	18	18		
20	91.3	94.0	92.8	84.8	76.0	67.9	59.6	-	-	-	-	-	-	-	-	20	20		
24	69.3	72.9	71.1	68.5	64.3	58.4	53.6	-	-	-	-	-	-	-	-	24	24		
28	-	54.3	57.5	56.1	52.4	47.9	44.8	41.3	-	-	-	-	-	-	-	28	28		
32	-	43.8	45.2	45.1	43.7	41.5	39.1	35.5	32.9	-	-	-	-	-	-	32	32		
36	-	36.2	37.4	37.4	36.5	36.0	33.7	31.1	28.7	20.3	25.5	23.4	-	-	-	36	36		
40	-	-	30.8	30.8	32.2	31.3	30.0	28.5	26.1	19.7	24.2	23.0	20.0	14.6	40	40			
48	-	-	22.7	24.2	23.9	23.7	23.5	22.9	21.6	18.2	18.1	19.9	18.4	14.6	48	48			
56	-	-	-	18.6	18.7	18.7	18.7	18.1	17.3	16.2	13.6	15.3	14.9	12.9	56	56			
64	-	-	-	14.9	15.0	14.8	14.6	14.2	14.0	13.1	10.1	11.7	11.2	9.6	64	64			
72	-	-	-	12.0	12.0	11.9	11.5	12.0	11.3	10.2	7.3	8.9	8.4	7.1	72	72			
80	-	-	-	-	9.7	9.6	9.4	9.6	8.9	8.1	5.3	6.8	6.5	5.0	80	80			
88	-	-	-	-	-	7.8	7.4	7.6	7.0	6.3	3.6	5.1	4.8	3.5	88	88			
96	-	-	-	-	-	6.4	5.9	6.1	5.5	4.8	2.3	3.7	3.6	2.3	96	96			
104	-	-	-	-	-	-	4.8	5.0	4.3	3.7	-	2.6	2.6	-	104	104			
112	-	-	-	-	-	-	-	3.9	3.2	2.6	-	-	-	-	112	112			
120	-	-	-	-	-	-	-	-	2.3	-	-	-	-	-	120	120			

10,400 lb		26.6 ft x 23.6 ft														360°		85 %	
ft		1,000 lb														ft			
10	157.1	157.4	153.0	130.5	-	-	-	-	-	-	-	-	-	-	-	-	-	10	
12	140.0	140.7	139.4	127.0	-	-	-	-	-	-	-	-	-	-	-	-	-	12	
14	125.7	126.6	126.2	121.9	103.8	-	-	-	-	-	-	-	-	-	-	-	-	14	
16	113.8	114.7	115.4	111.6	97.6	-	-	-	-	-	-	-	-	-	-	-	-	16	
18	102.1	103.4	103.1	96.9	86.2	69.8	-	-	-	-	-	-	-	-	-	-	-	18	
20	90.3	93.0	90.4	82.7	74.0	67.7	59.5	-	-	-	-	-	-	-	-	-	-	20	
24	67.4	71.0	69.2	67.7	62.7	56.8	52.6	-	-	-	-	-	-	-	-	-	-	24	
28	-	52.8	55.8	54.7	51.1	47.1	43.4	40.2	-	-	-	-	-	-	-	-	-	28	
32	-	42.6	43.9	43.9	42.4	40.5	38.0	34.7	32.1	-	-	-	-	-	-	-	-	32	
36	-	35.1	36.4	36.4	35.4	35.6	32.6	30.6	28.2	20.3	25.1	23.4	-	-	-	-	-	36	
40	-	-	30.0	30.0	31.3	30.4	29.1	27.4	26.0	19.7	23.3	22.9	19.9	14.6	-	-	-	40	
48	-	-	22.4	23.4	23.1	23.5	22.9	22.6	21.2	18.2	17.3	19.0	17.6	14.4	-	-	-	48	
56	-	-	-	18.2	18.5	18.1	18.1	17.4	16.6	15.8	12.9	14.5	14.1	12.3	-	-	-	56	
64	-	-	-	14.4	14.4	14.2	14.2	14.0	13.7	12.3	9.5	11.0	10.6	9.0	-	-	-	64	
72	-	-	-	11.5	11.5	11.5	11.1	11.3	10.6	9.5	6.7	8.2	8.0	6.4	-	-	-	72	
80	-	-	-	-	9.6	9.2	8.7	9.1	8.3	7.5	4.8	6.3	5.9	4.6	-	-	-	80	
88	-	-	-	-	-	7.4	7.0	7.2	6.5	5.8	3.2	4.6	4.4	3.1	-	-	-	88	
96	-	-	-	-	-	5.9	5.5	5.7	5.0	4.4	-	3.3	3.2	-	-	-	-	96	
104	-	-	-	-	-	-	4.3	4.5	3.9	3.2	-	2.1	2.1	-	-	-	-	104	
112	-	-	-	-	-	-	-	3.5	2.8	2.2	-	-	-	-	-	-	-	112	
120	-	-	-	-	-	-	-	-	2.0	-	-	-	-	-	-	-	-	120	

## Telescoping capacities

		26.6 ft x 23.6 ft											360°		85 %		
ft		1,000 lb											ft				
10	60.8	55.9	51.9	-	-	-	-	-	-	-	-	-	-	-	-	-	10
12	58.1	54.9	50.9	-	-	-	-	-	-	-	-	-	-	-	-	-	12
14	57.6	54.1	49.8	48.7	-	-	-	-	-	-	-	-	-	-	-	-	14
16	57.2	53.3	48.9	47.6	-	-	-	-	-	-	-	-	-	-	-	-	16
18	57.0	52.6	48.0	46.6	41.1	-	-	-	-	-	-	-	-	-	-	-	18
20	56.9	51.8	47.1	45.8	40.2	39.6	-	-	-	-	-	-	-	-	-	-	20
24	56.7	48.4	45.9	43.8	38.6	37.8	-	-	-	-	-	-	-	-	-	-	24
28	57.2	47.5	45.4	40.5	37.1	35.4	32.1	-	-	-	-	-	-	-	-	-	28
32	58.4	46.8	42.1	37.9	35.8	32.9	30.7	29.0	-	-	-	-	-	-	-	-	32
36	54.8	46.5	40.3	35.8	34.6	30.9	28.5	27.4	23.4	-	-	-	-	-	-	-	36
40	-	45.7	39.0	34.9	33.6	29.6	26.3	25.6	22.9	18.0	-	-	-	-	-	-	40
48	-	37.8	34.8	33.2	31.3	25.5	24.5	23.7	19.9	16.8	-	-	-	-	-	-	48
56	-	-	29.5	29.9	28.3	23.7	22.9	21.5	17.1	14.5	-	-	-	-	-	-	56
64	-	-	25.2	24.6	25.3	22.3	21.4	19.4	14.8	12.5	-	-	-	-	-	-	64
72	-	-	9.5	20.4	21.5	20.1	20.3	17.9	12.6	10.6	-	-	-	-	-	-	72
80	-	-	-	2.6	18.1	17.2	17.4	16.3	11.3	9.1	-	-	-	-	-	-	80
88	-	-	-	-	15.6	15.7	14.8	14.7	9.9	8.1	-	-	-	-	-	-	88
96	-	-	-	-	11.4	13.8	12.7	12.7	8.6	7.2	-	-	-	-	-	-	96
104	-	-	-	-	-	12.1	10.8	10.8	7.6	6.1	-	-	-	-	-	-	104
112	-	-	-	-	-	-	9.4	9.4	6.8	5.3	-	-	-	-	-	-	112
120	-	-	-	-	-	-	8.1	8.1	6.0	4.7	-	-	-	-	-	-	120
128	-	-	-	-	-	-	-	6.8	5.3	4.1	-	-	-	-	-	-	128
136	-	-	-	-	-	-	-	5.9	4.8	3.4	-	-	-	-	-	-	136
144	-	-	-	-	-	-	-	-	4.2	3.1	-	-	-	-	-	-	144
152	-	-	-	-	-	-	-	-	-	2.6	-	-	-	-	-	-	152
160	-	-	-	-	-	-	-	-	-	2.3	-	-	-	-	-	-	160

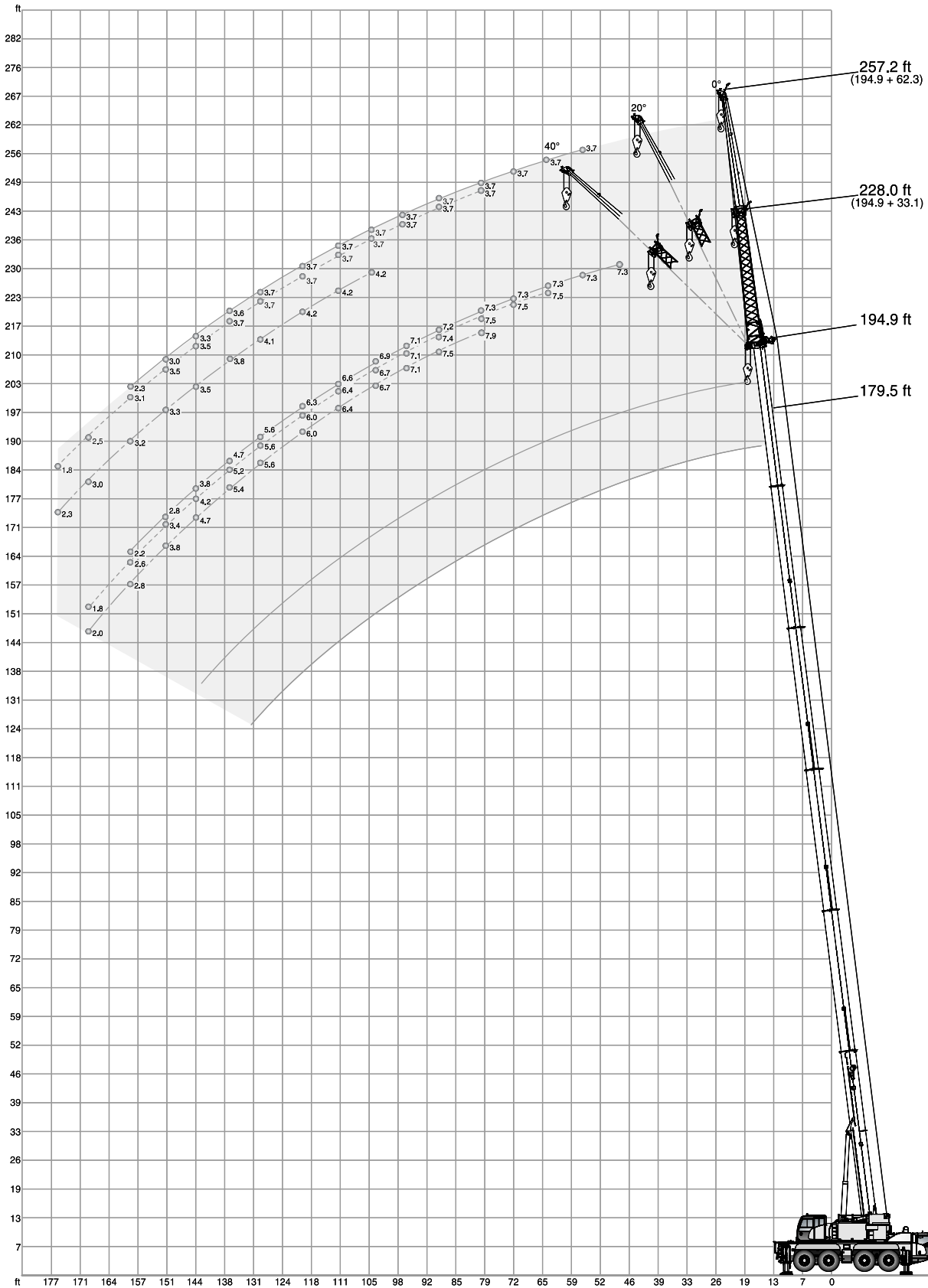
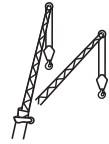

57,500 lb		26.6 ft x 23.6 ft		360°		85 %	
<b>194.9 ft</b>							
		33.1 ft			62.3 ft		
		0°	20°	40°	0°	20°	40°
ft	1,000 lb						
48	7.3	-	-	-	-	-	-
56	7.3	-	-	3.7	-	-	-
64	7.3	7.5	-	3.7	-	-	-
72	7.3	7.5	-	3.7	-	-	-
80	7.3	7.5	7.9	3.7	3.7	-	-
88	7.2	7.4	7.5	3.7	3.7	-	-
96	7.1	7.1	7.1	3.7	3.7	-	-
104	6.9	6.7	6.7	3.7	3.7	4.2	-
112	6.6	6.4	6.4	3.7	3.7	4.2	-
120	6.3	6.0	6.0	3.7	3.7	4.2	-
128	5.6	5.6	5.6	3.7	3.7	4.1	-
136	4.7	5.2	5.4	3.6	3.7	3.8	-
144	3.8	4.2	4.7	3.3	3.5	3.5	-
152	2.8	3.4	3.8	3.0	3.5	3.3	-
160	2.2	2.6	2.8	2.3	3.1	3.2	-
168	-	1.8	2.0	-	2.5	3.0	-
176	-	-	-	-	1.8	2.3	-
<b>179.5 ft</b>							
		33.1 ft			62.3 ft		
		0°	20°	40°	0°	20°	40°
ft	1,000 lb						
48	10.4	-	-	5.5	-	-	-
56	10.4	-	-	5.5	-	-	-
64	10.4	10.4	-	5.5	-	-	-
72	10.4	10.4	-	5.5	-	-	-
80	9.9	10.3	10.5	5.5	5.5	-	-
88	9.6	10.0	10.2	5.5	5.5	-	-
96	9.2	9.4	9.6	5.5	5.5	6.2	-
104	8.7	8.9	8.9	5.5	5.5	6.0	-
112	8.1	8.1	8.3	5.5	5.5	5.7	-
120	7.2	7.6	7.8	5.4	5.5	5.5	-
128	5.9	6.7	7.0	5.2	5.5	5.4	-
136	5.4	5.5	5.8	4.9	5.4	5.3	-
144	4.5	4.9	4.9	4.0	5.1	5.1	-
152	3.6	4.1	4.5	3.5	4.3	4.8	-
160	2.9	3.3	3.5	3.1	3.5	4.1	-
168	2.2	2.6	2.7	2.4	3.0	3.1	-
176	-	1.9	-	1.8	2.5	2.7	-
184	-	-	-	-	-	2.2	-

<b>165.4 ft</b>							
		33.1 ft			62.3 ft		
		0°	20°	40°	0°	20°	40°
ft	1,000 lb						
40	13.9	-	-	-	-	-	-
48	13.9	-	-	7.7	-	-	-
56	13.8	13.9	-	7.7	-	-	-
64	13.5	13.6	-	7.7	-	-	-
72	12.8	13.0	13.2	7.7	-	-	-
80	12.0	12.4	12.4	7.5	7.5	-	-
88	11.2	11.4	11.6	7.4	7.5	-	-
96	10.4	10.5	10.7	7.3	7.5	7.1	-
104	9.6	9.6	9.8	7.3	7.3	6.9	-
112	8.3	8.8	9.0	6.8	7.0	6.8	-
120	7.5	7.7	8.1	6.5	6.8	6.6	-
128	6.6	7.1	7.2	5.8	6.6	6.6	-
136	5.5	6.2	6.4	5.1	5.9	6.3	-
144	4.7	5.1	5.3	4.9	5.1	5.8	-
152	4.1	4.1	4.3	3.9	4.6	4.7	-
160	3.7	3.7	-	3.1	3.9	4.5	-
168	3.3	3.4	-	2.7	3.3	3.8	-
176	2.5	2.8	-	2.5	2.5	3.0	-
184	-	-	-	2.2	2.2	-	-
192	-	-	-	-	2.1	-	-

<b>39.4 ft</b>							
		33.1 ft			62.3 ft		
		0°	20°	40°	0°	20°	40°
ft	1,000 lb						
10	29.1	-	-	19.2	-	-	-
12	29.1	-	-	19.1	-	-	-
14	29.1	-	-	18.8	-	-	-
16	29.1	-	-	18.6	-	-	-
18	29.1	28.7	-	18.4	-	-	-
20	29.1	28.0	-	18.2	-	-	-
24	28.9	26.0	-	17.5	-	-	-
28	28.0	24.4	20.3	17.0	-	-	-
32	26.9	22.8	19.3	16.3	-	-	-
36	25.5	21.5	18.5	15.6	13.6	-	-
40	24.0	20.3	17.8	14.9	12.9	-	-
48	20.9	18.3	16.8	13.3	11.6	-	-
56	18.3	17.1	-	12.1	10.7	9.2	-
64	-	-	-	11.0	9.9	8.7	-
72	-	-	-	9.9	9.1	8.2	-
80	-	-	-	9.1	8.6	-	-



**47,000 lb**      **26.6 ft x 23.6 ft**      **360°**      **85 %**

**194.9 ft**

ft	33.1 ft			62.3 ft		
	0°	20°	40°	0°	20°	40°
	1,000 lb					
48	7.3	-	-	-	-	-
56	7.3	-	-	3.7	-	-
64	7.3	7.5	-	3.7	-	-
72	7.3	7.5	-	3.7	-	-
80	7.3	7.5	7.9	3.7	3.7	-
88	7.2	7.4	7.5	3.7	3.7	-
96	7.1	7.1	7.1	3.7	3.7	-
104	6.9	6.7	6.7	3.7	3.7	4.2
112	6.3	6.4	6.4	3.7	3.7	4.2
120	5.0	5.9	6.0	3.7	3.7	4.2
128	4.1	4.8	5.3	3.5	3.7	4.1
136	3.1	3.8	4.2	2.8	3.7	3.8
144	2.2	2.9	3.3	2.0	3.1	3.5
152	-	-	2.3	-	2.4	3.2
160	-	-	-	-	-	2.6
168	-	-	-	-	-	1.8

**179.5 ft**

ft	33.1 ft			62.3 ft		
	0°	20°	40°	0°	20°	40°
	1,000 lb					
48	10.4	-	-	5.5	-	-
56	10.4	-	-	5.5	-	-
64	10.4	10.4	-	5.5	-	-
72	10.4	10.4	-	5.5	-	-
80	9.9	10.3	10.5	5.5	5.5	-
88	9.6	10.0	10.2	5.5	5.5	-
96	9.2	9.4	9.6	5.5	5.5	6.2
104	8.1	8.9	8.9	5.5	5.5	6.0
112	6.8	7.6	8.3	5.5	5.5	5.7
120	6.1	6.3	6.7	5.3	5.5	5.5
128	5.0	5.4	5.6	4.3	5.4	5.4
136	4.0	4.6	4.9	3.8	4.7	5.3
144	3.1	3.6	4.0	3.1	3.8	4.7
152	2.3	2.8	3.0	2.4	3.2	3.6
160	-	2.0	2.2	-	2.6	3.1
168	-	-	-	-	1.9	2.5
176	-	-	-	-	-	1.7

**165.4 ft**

ft	33.1 ft			62.3 ft		
	0°	20°	40°	0°	20°	40°
	1,000 lb					
40	13.9	-	-	-	-	-
48	13.9	-	-	7.7	-	-
56	13.8	13.9	-	7.7	-	-
64	13.5	13.6	-	7.7	-	-
72	12.8	13.0	13.2	7.7	-	-
80	12.0	12.4	12.4	7.5	7.5	-
88	11.2	11.4	11.6	7.4	7.5	-
96	9.7	10.5	10.7	7.3	7.5	7.1
104	8.9	8.9	9.6	7.3	7.3	6.9
112	7.4	8.3	8.3	6.5	7.0	6.8
120	6.1	7.0	7.4	5.7	6.6	6.6
128	5.5	5.6	6.1	5.2	5.6	6.4
136	4.8	5.0	5.0	4.2	5.2	5.5
144	4.0	4.4	4.6	3.5	4.4	4.9
152	3.2	3.6	3.8	3.2	3.4	4.1
160	2.5	2.8	-	2.7	3.0	3.3
168	1.9	2.2	-	2.2	2.6	2.7
176	-	-	-	-	2.1	2.3

**39.4 ft**

ft	33.1 ft			62.3 ft		
	0°	20°	40°	0°	20°	40°
	1,000 lb					
10	29.1	-	-	19.2	-	-
12	29.1	-	-	19.1	-	-
14	29.1	-	-	18.8	-	-
16	29.1	-	-	18.6	-	-
18	29.1	28.7	-	18.4	-	-
20	29.1	28.0	-	18.2	-	-
24	28.9	26.0	-	17.5	-	-
28	28.0	24.4	20.3	17.0	-	-
32	26.9	22.8	19.3	16.3	-	-
36	25.5	21.5	18.5	15.6	13.6	-
40	24.0	20.3	17.8	14.9	12.9	-
48	20.9	18.3	16.8	13.3	11.6	-
56	18.3	17.1	-	12.1	10.7	9.2
64	-	-	-	11.0	9.9	8.7
72	-	-	-	9.9	9.1	8.2
80	-	-	-	9.1	8.6	-

**22,300 lb**      **26.6 ft x 23.6 ft**      **360°**      **85 %**

**194.9 ft**

ft	33.1 ft			62.3 ft		
	0°	20°	40°	0°	20°	40°
	1,000 lb					
48	7.3	-	-	-	-	-
56	7.3	-	-	3.7	-	-
64	7.3	7.5	-	3.7	-	-
72	7.3	7.5	-	3.7	-	-
80	6.8	7.4	7.9	3.7	3.7	-
88	5.0	6.4	7.3	3.7	3.7	-
96	3.5	4.7	5.8	3.1	3.7	-
104	2.3	3.4	4.4	1.9	3.7	4.2
112	-	-	3.0	-	2.6	4.1
120	-	-	-	-	-	3.1
128	-	-	-	-	-	2.2

**179.5 ft**

ft	33.1 ft			62.3 ft		
	0°	20°	40°	0°	20°	40°
	1,000 lb					
48	10.4	-	-	5.5	-	-
56	10.4	-	-	5.5	-	-
64	10.4	10.4	-	5.5	-	-
72	9.7	10.4	-	5.5	-	-
80	8.3	9.1	10.2	5.5	5.5	-
88	6.5	7.6	8.2	5.1	5.5	-
96	4.9	6.0	6.8	4.3	5.5	6.2
104	3.7	4.6	5.5	3.2	4.7	6.0
112	2.6	3.5	4.1	-	3.9	4.8
120	-	2.5	3.1	-	2.8	4.2
128	-	-	2.1	-	1.9	3.1
136	-	-	-	-	-	2.2

**165.4 ft**

ft	33.1 ft			62.3 ft		
	0°	20°	40°	0°	20°	40°
	1,000 lb					
40	13.9	-	-	-	-	-
48	13.9	-	-	7.7	-	-
56	13.8	13.9	-	7.7	-	-
64	12.7	13.6	-	7.7	-	-
72	11.0	11.7	13.2	7.7	-	-
80	8.7	10.2	10.6	7.2	7.5	-
88	7.9	8.2	9.2	6.3	7.3	-
96	6.4	7.1	7.3	5.4	6.5	7.1
104	5.0	5.9	6.5	4.7	5.5	6.3
112	3.9	4.8	5.2	3.7	4.6	5.7
120	2.9	3.7	4.2	2.7	4.0	4.4
128	2.1	2.6	3.1	1.9	3.2	3.9
136	-	1.7	2.2	-	2.4	3.3
144	-	-	-	-	1.6	2.5

**39.4 ft**

ft	33.1 ft			62.3 ft		
	0°	20°	40°	0°	20°	40°
	1,000 lb					
10	29.1	-	-	19.2	-	-
12	29.1	-	-	19.1	-	-
14	29.1	-	-	18.8	-	-
16	29.1	-	-	18.6	-	-
18	29.1	28.7	-	18.4	-	-
20	29.1	28.0	-	18.2	-	-
24	28.9	26.0	-	17.5	-	-
28	28.0	24.4	20.3	17.0	-	-
32	26.9	22.8	19.3	16.3	-	-
36	25.5	21.5	18.5	15.6	13.6	-
40	24.0	20.3	17.8	14.9	12.9	-
48	20.9	18.3	16.8	13.3	11.6	-
56	18.3	17.1	-	12.1	10.7	9.2
64	-	-	-	11.0	9.9	8.7
72	-	-	-	9.9	9.1	8.2
80	-	-	-	9.1	8.6	-

**11,900 lb**      **26.6 ft x 23.6 ft**      **360°**      **85 %**

**194.9 ft**

ft	33.1 ft			62.3 ft		
	0°	20°	40°	0°	20°	40°
	1,000 lb					
48	7.3	-	-	-	-	-
56	7.3	-	-	3.7	-	-
64	7.3	7.5	-	3.7	-	-
72	5.3	7.1	-	3.7	-	-
80	3.5	5.0	6.5	2.9	-	-
88	-	3.4	4.5	-	-	-
96	-	2.1	3.1	-	-	-
104	-	-	1.9	-	-	-

**179.5 ft**

ft	33.1 ft			62.3 ft		
	0°	20°	40°	0°	20°	40°
	1,000 lb					
48	10.4	-	-	5.5	-	-
56	10.4	-	-	5.5	-	-
64	9.1	10.2	-	5.5	-	-
72	7.1	8.6	8.8	5.5	-	-
80	5.0	6.5	7.6	4.4	5.5	-
88	3.5	4.7	5.8	3.1	4.9	-
96	2.3	3.3	4.2	-	3.8	5.3
104	-	2.1	3.0	-	2.6	4.3
112	-	-	-	-	-	3.0

**165.4 ft**

ft	33.1 ft			62.3 ft		
	0°	20°	40°	0°	20°	40°
	1,000 lb					
40	13.9	-	-	-	-	-
48	13.9	-	-	7.7	-	-
56	12.2	13.4	-	7.7	-	-
64	10.1	11.6	-	7.7	-	-
72	8.6	9.1	10.6	6.6	-	-
80	6.8	7.9	8.1	5.6	6.8	-
88	5.1	6.1	7.1	4.6	5.8	-
96	3.7	4.6	5.5	3.3	4.9	6.0
104	2.6	3.4	4.1	2.3	3.9	4.7
112	-	2.4	3.0	-	2.8	4.1
120	-	-	2.0	-	-	3.1
128	-	-	-	-	-	2.1

**39.4 ft**

ft	33.1 ft			62.3 ft		
	0°	20°	40°	0°	20°	40°
	1,000 lb					
10	29.1	-	-	19.2	-	-
12	29.1	-	-	19.1	-	-
14	29.1	-	-	18.8	-	-
16	29.1	-	-	18.6	-	-
18	29.1	28.7	-	18.4	-	-
20	29.1	28.0	-	18.2	-	-
24	28.9	26.0	-	17.5	-	-
28	28.0	24.4	20.3	17.0	-	-
32	26.9	22.8	19.3	16.3	-	-
36	25.5	21.5	18.5	15.6	13.6	-
40	24.0	20.3	17.8	14.9	12.9	-
48	20.9	18.3	16.8	13.3	11.6	-
56	18.1	17.1	-	12.1	10.7	9.2
64	-	-	-	11.0	9.9	8.7
72	-	-	-	9.9	9.1	8.2
80	-	-	-	9.1	8.6	-

**10,400 lb**      **26.6 ft x 23.6 ft**      **360°**      **85 %**

**194.9 ft**

ft	33.1 ft			62.3 ft		
	0°	20°	40°	0°	20°	40°
1,000 lb						
48	7.3	-	-	-	-	-
56	7.3	-	-	3.7	-	-
64	6.8	7.5	-	3.7	-	-
72	4.9	6.6	-	3.7	-	-
80	3.1	4.6	5.9	-	-	-
88	-	3.0	4.1	-	-	-
96	-	-	2.6	-	-	-

**179.5 ft**

ft	33.1 ft			62.3 ft		
	0°	20°	40°	0°	20°	40°
1,000 lb						
48	10.4	-	-	5.5	-	-
56	10.1	-	-	5.5	-	-
64	8.6	9.7	-	5.5	-	-
72	6.4	8.0	8.8	5.1	-	-
80	4.6	5.9	7.2	3.9	5.4	-
88	3.1	4.3	5.4	2.5	4.7	-
96	-	2.8	3.8	-	3.5	4.9
104	-	1.7	2.6	-	2.2	3.9
112	-	-	-	-	-	2.8







**165.4 ft**

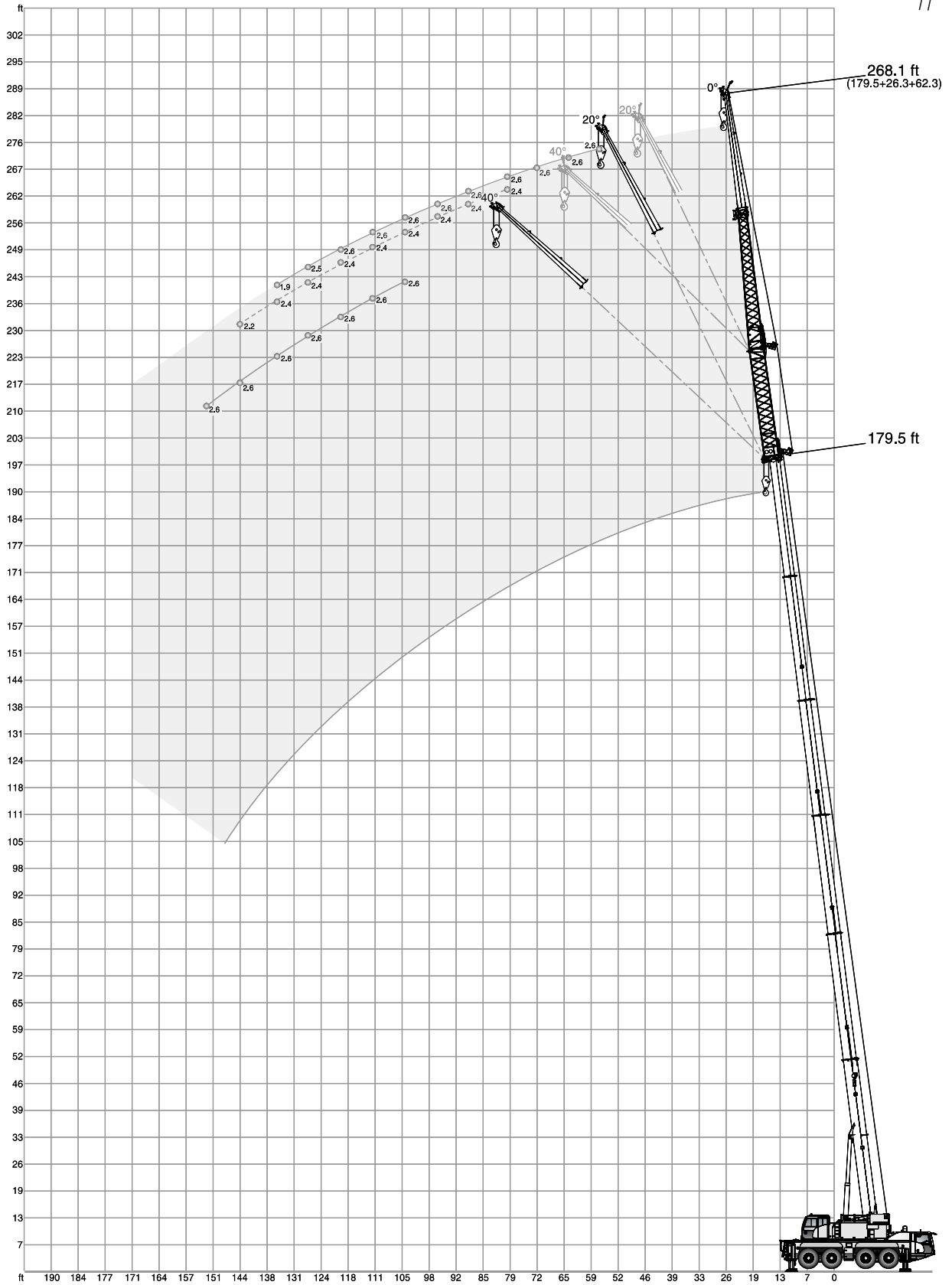
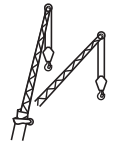

ft	33.1 ft			62.3 ft		
	0°	20°	40°	0°	20°	40°
1,000 lb						
40	13.9	-	-	-	-	-
48	13.7	-	-	7.7	-	-
56	11.9	13.1	-	7.7	-	-
64	10.0	11.1	-	7.4	-	-
72	8.2	9.1	10.0	6.4	-	-
80	6.1	7.4	8.0	5.5	6.5	-
88	4.6	5.6	6.6	4.2	5.4	-
96	3.3	4.3	5.0	2.8	4.7	5.7
104	2.3	3.0	3.7	1.9	3.5	4.7
112	-	-	2.6	-	2.4	3.7
120	-	-	-	-	-	2.8



**39.4 ft**









ft	33.1 ft			62.3 ft		
	0°	20°	40°	0°	20°	40°
1,000 lb						
10	29.1	-	-	19.2	-	-
12	29.1	-	-	19.1	-	-
14	29.1	-	-	18.8	-	-
16	29.1	-	-	18.6	-	-
18	29.1	28.7	-	18.4	-	-
20	29.1	28.0	-	18.2	-	-
24	28.9	26.0	-	17.5	-	-
28	28.0	24.4	20.3	17.0	-	-
32	26.9	22.8	19.3	16.3	-	-
36	25.5	21.5	18.5	15.6	13.6	-
40	24.0	20.3	17.8	14.9	12.9	-
48	20.9	18.3	16.8	13.3	11.6	-
56	17.9	17.1	-	12.1	10.7	9.2
64	-	-	-	11.0	9.9	8.7
72	-	-	-	9.9	9.1	8.2
80	-	-	-	9.1	8.6	-









57,500 lb		26.6 ft x 23.6 ft		360°		85 %																																	
 <b>179.5 ft</b>		 <b>165.4 ft</b>		 <b>151.6 ft</b>																																			
 <table border="1"> <thead> <tr> <th colspan="2">26.3 ft</th> </tr> <tr> <th>0°</th> <th>0°</th> </tr> </thead> <tbody> <tr> <td colspan="2">62.3 ft</td> </tr> <tr> <th>0°</th> <th>20°</th> </tr> </tbody> </table>		26.3 ft		0°	0°	62.3 ft		0°	20°	 <table border="1"> <thead> <tr> <th colspan="2">26.3 ft</th> </tr> <tr> <th>0°</th> <th>0°</th> </tr> </thead> <tbody> <tr> <td colspan="2">62.3 ft</td> </tr> <tr> <th>0°</th> <th>20°</th> </tr> </tbody> </table>		26.3 ft		0°	0°	62.3 ft		0°	20°	 <table border="1"> <thead> <tr> <th colspan="4">26.3 ft</th> </tr> <tr> <th>0°</th> <th>0°</th> <th>0°</th> <th>20°</th> </tr> </thead> <tbody> <tr> <td colspan="4">62.3 ft</td> </tr> <tr> <th>0°</th> <th>20°</th> <th>40°</th> <th>0°</th> </tr> </tbody> </table>		26.3 ft				0°	0°	0°	20°	62.3 ft				0°	20°	40°	0°		
26.3 ft																																							
0°	0°																																						
62.3 ft																																							
0°	20°																																						
26.3 ft																																							
0°	0°																																						
62.3 ft																																							
0°	20°																																						
26.3 ft																																							
0°	0°	0°	20°																																				
62.3 ft																																							
0°	20°	40°	0°																																				
ft		ft		ft		1,000 lb																																	
56	2.6	-	56	4.4	-	48	6.3																																
64	2.6	-	64	4.4	-	56	6.2																																
72	2.6	-	72	4.4	-	64	6.0																																
80	2.6	-	80	4.4	4.2	72	5.7																																
88	2.6	-	88	4.4	4.2	80	5.7																																
96	2.6	-	96	4.3	4.2	88	5.5																																
104	2.6	-	104	4.2	4.2	96	5.4																																
112	2.6	-	112	4.2	4.2	104	5.1																																
120	2.6	-	120	4.1	4.1	112	5.1																																
128	2.6	-	128	3.9	4.0	120	4.8																																
136	2.6	-	136	3.6	4.0	128	4.5																																
144	2.4	-	144	2.9	3.8	136	3.9																																
			152	2.6	3.2	144	3.5																																
			160	2.2	2.4	152	3.1																																
						160	2.7																																
						168	2.2																																
						176	1.8																																

 <b>137.5 ft</b>																									
 <table border="1"> <thead> <tr> <th colspan="5">26.3 ft</th> </tr> <tr> <th>0°</th> <th>0°</th> <th>0°</th> <th>20°</th> <th>40°</th> </tr> </thead> <tbody> <tr> <td colspan="5">62.3 ft</td> </tr> <tr> <th>0°</th> <th>20°</th> <th>40°</th> <th>0°</th> <th>0°</th> </tr> </tbody> </table>		26.3 ft					0°	0°	0°	20°	40°	62.3 ft					0°	20°	40°	0°	0°				
26.3 ft																									
0°	0°	0°	20°	40°																					
62.3 ft																									
0°	20°	40°	0°	0°																					
ft				1,000 lb																					
48	7.4	-	-	-	-																				
56	7.2	-	-	-	-																				
64	6.9	-	-	-	-																				
72	6.8	6.8	-	-	-																				
80	6.6	6.6	-	6.1	-																				
88	6.3	6.3	5.9	5.6	-																				
96	6.0	6.0	5.7	5.4	-																				
104	5.8	5.8	5.5	5.3	4.4																				
112	5.7	5.5	5.3	5.1	4.2																				
120	5.4	5.2	5.0	4.8	4.1																				
128	5.1	5.0	4.9	4.5	4.0																				
136	4.7	4.9	4.7	4.4	3.8																				
144	3.8	4.4	4.6	4.2	3.7																				
152	3.3	3.9	4.3	3.9	3.7																				
160	2.9	3.1	3.7	3.3	3.6																				
168	2.4	2.7	2.8	2.5	2.9																				
176	2.0	2.3	1.9	1.8	1.9																				

 <b>39.4 ft</b>																									
 <table border="1"> <thead> <tr> <th colspan="5">26.3 ft</th> </tr> <tr> <th>0°</th> <th>0°</th> <th>0°</th> <th>20°</th> <th>40°</th> </tr> </thead> <tbody> <tr> <td colspan="5">62.3 ft</td> </tr> <tr> <th>0°</th> <th>20°</th> <th>40°</th> <th>0°</th> <th>0°</th> </tr> </tbody> </table>		26.3 ft					0°	0°	0°	20°	40°	62.3 ft					0°	20°	40°	0°	0°				
26.3 ft																									
0°	0°	0°	20°	40°																					
62.3 ft																									
0°	20°	40°	0°	0°																					
ft				1,000 lb																					
16	15.9	-	-	-	-																				
18	15.8	-	-	-	-																				
20	15.6	-	-	-	-																				
24	14.8	-	-	-	-																				
28	14.1	-	-	-	-																				
32	13.4	-	-	-	-																				
36	12.6	-	-	-	-																				
40	11.8	10.7	-	-	-																				
48	10.3	9.4	-	8.8	-																				
56	9.2	8.5	-	7.8	-																				
64	8.2	7.7	7.2	7.2	-																				
72	7.3	6.9	6.6	6.4	-																				
80	6.7	6.3	6.1	5.9	5.2																				
88	6.0	5.8	5.6	5.3	4.8																				
96	5.5	5.2	5.4	4.9	4.5																				
104	4.9	4.9	-	4.7	4.4																				

47,000 lb		26.6 ft x 23.6 ft		360°		85 %																																	
 <b>179.5 ft</b>		 <b>165.4 ft</b>		 <b>151.6 ft</b>																																			
  <table border="1"> <thead> <tr> <th colspan="2">26.3 ft</th> </tr> <tr> <th>0°</th> <th>0°</th> </tr> </thead> <tbody> <tr> <td colspan="2">62.3 ft</td> </tr> <tr> <th>0°</th> <th>20°</th> </tr> </tbody> </table>		26.3 ft		0°	0°	62.3 ft		0°	20°	  <table border="1"> <thead> <tr> <th colspan="2">26.3 ft</th> </tr> <tr> <th>0°</th> <th>0°</th> </tr> </thead> <tbody> <tr> <td colspan="2">62.3 ft</td> </tr> <tr> <th>0°</th> <th>20°</th> </tr> </tbody> </table>		26.3 ft		0°	0°	62.3 ft		0°	20°	  <table border="1"> <thead> <tr> <th colspan="4">26.3 ft</th> </tr> <tr> <th>0°</th> <th>0°</th> <th>0°</th> <th>20°</th> </tr> </thead> <tbody> <tr> <td colspan="4">62.3 ft</td> </tr> <tr> <th>0°</th> <th>20°</th> <th>40°</th> <th>0°</th> </tr> </tbody> </table>		26.3 ft				0°	0°	0°	20°	62.3 ft				0°	20°	40°	0°		
26.3 ft																																							
0°	0°																																						
62.3 ft																																							
0°	20°																																						
26.3 ft																																							
0°	0°																																						
62.3 ft																																							
0°	20°																																						
26.3 ft																																							
0°	0°	0°	20°																																				
62.3 ft																																							
0°	20°	40°	0°																																				
ft		ft		ft		1,000 lb																																	
56	2.6	-	56	4.4	-	48	6.3																																
64	2.6	-	64	4.4	-	56	6.2																																
72	2.6	-	72	4.4	-	64	6.0																																
80	2.6	-	80	4.4	4.2	72	5.7																																
88	2.6	-	88	4.4	4.2	80	5.7																																
96	2.6	-	96	4.3	4.2	88	5.5																																
104	2.6	-	104	4.2	4.2	96	5.4																																
112	2.6	-	112	4.2	4.2	104	5.1																																
120	2.6	-	120	3.9	4.1	112	5.0																																
128	2.5	-	128	3.2	4.0	120	4.4																																
136	1.9	-	136	2.8	3.3	128	3.9																																
			144	2.0	2.5	136	3.4																																
						144	3.1																																
						152	2.5																																

 <b>137.5 ft</b>																									
  <table border="1"> <thead> <tr> <th colspan="5">26.3 ft</th> </tr> <tr> <th>0°</th> <th>0°</th> <th>0°</th> <th>20°</th> <th>40°</th> </tr> </thead> <tbody> <tr> <td colspan="5">62.3 ft</td> </tr> <tr> <th>0°</th> <th>20°</th> <th>40°</th> <th>0°</th> <th>0°</th> </tr> </tbody> </table>		26.3 ft					0°	0°	0°	20°	40°	62.3 ft					0°	20°	40°	0°	0°				
26.3 ft																									
0°	0°	0°	20°	40°																					
62.3 ft																									
0°	20°	40°	0°	0°																					
ft		ft		1,000 lb																					
48	7.4	-	-	-	-	-	-																		
56	7.2	-	-	-	-	-	-																		
64	6.9	-	-	-	-	-	-																		
72	6.8	6.8	-	-	-	-	-																		
80	6.6	6.6	-	6.1	-	-	-																		
88	6.3	6.3	5.9	5.6	-	-	-																		
96	6.0	6.0	5.7	5.4	-	-	-																		
104	5.8	5.8	5.5	5.3	4.4	-	-																		
112	5.7	5.5	5.3	5.1	4.2	-	-																		
120	5.1	5.2	5.0	4.8	4.1	-	-																		
128	4.3	5.0	4.9	4.5	4.0	-	-																		
136	4.0	4.4	4.7	4.2	3.8	-	-																		
144	3.3	3.8	4.2	3.8	3.7	-	-																		
152	2.8	3.4	3.4	2.9	3.6	-	-																		
160	2.5	2.6	2.4	2.0	2.6	-	-																		
168	1.9	1.9	-	-	-	-	-																		

 <b>39.4 ft</b>																									
  <table border="1"> <thead> <tr> <th colspan="5">26.3 ft</th> </tr> <tr> <th>0°</th> <th>0°</th> <th>0°</th> <th>20°</th> <th>40°</th> </tr> </thead> <tbody> <tr> <td colspan="5">62.3 ft</td> </tr> <tr> <th>0°</th> <th>20°</th> <th>40°</th> <th>0°</th> <th>0°</th> </tr> </tbody> </table>		26.3 ft					0°	0°	0°	20°	40°	62.3 ft					0°	20°	40°	0°	0°				
26.3 ft																									
0°	0°	0°	20°	40°																					
62.3 ft																									
0°	20°	40°	0°	0°																					
ft		ft		1,000 lb																					
16	15.9	-	-	-	-	-	-																		
18	15.8	-	-	-	-	-	-																		
20	15.6	-	-	-	-	-	-																		
24	14.8	-	-	-	-	-	-																		
28	14.1	-	-	-	-	-	-																		
32	13.4	-	-	-	-	-	-																		
36	12.6	-	-	-	-	-	-																		
40	11.8	10.7	-	-	-	-	-																		
48	10.3	9.4	-	8.8	-	-	-																		
56	9.2	8.5	-	7.8	-	-	-																		
64	8.2	7.7	7.2	7.2	-	-	-																		
72	7.3	6.9	6.6	6.4	-	-	-																		
80	6.7	6.3	6.1	5.9	5.2	-	-																		
88	6.0	5.8	5.6	5.3	4.8	-	-																		
96	5.5	5.2	5.4	4.9	4.5	-	-																		
104	4.9	4.9	-	4.7	4.4	-	-																		

43,700 lb		26.6 ft x 23.6 ft		360°		85 %	
<b>179.5 ft</b>							
		26.3 ft		0°		0°	
		62.3 ft		0°		20°	
ft	1,000 lb						
56	2.6	-	-	-	-	-	-
64	2.6	-	-	-	-	-	-
72	2.6	-	-	-	-	-	-
80	2.6	-	-	-	-	-	-
88	2.6	-	-	-	-	-	-
96	2.6	-	-	-	-	-	-
104	2.6	-	-	-	-	-	-
112	2.6	-	-	-	-	-	-
120	2.6	-	-	-	-	-	-
128	2.2	-	-	-	-	-	-
<b>165.4 ft</b>							
		26.3 ft		0°		0°	
		62.3 ft		0°		20°	
ft	1,000 lb						
56	4.4	-	-	-	-	-	-
64	4.4	-	-	-	-	-	-
72	4.4	-	-	-	-	-	-
80	4.4	4.2	-	-	-	-	-
88	4.4	4.2	-	-	-	-	-
96	4.3	4.2	-	-	-	-	-
104	4.2	4.2	-	-	-	-	-
112	4.1	4.2	-	-	-	-	-
120	3.3	4.1	-	-	-	-	-
128	3.1	3.7	-	-	-	-	-
136	2.4	2.9	-	-	-	-	-
144	1.6	2.0	-	-	-	-	-
<b>151.6 ft</b>							
		26.3 ft		0°		0°	
		62.3 ft		0°		20°	
ft	1,000 lb						
48	6.3	-	-	-	-	-	-
56	6.2	-	-	-	-	-	-
64	6.0	-	-	-	-	-	-
72	5.7	-	-	-	-	-	-
80	5.7	5.7	-	-	-	-	-
88	5.5	5.6	-	-	5.4	-	-
96	5.4	5.4	5.5	5.2	-	-	-
104	5.1	5.3	5.3	4.9	-	-	-
112	5.0	5.1	5.1	4.8	-	-	-
120	4.2	4.9	5.0	4.6	-	-	-
128	3.6	4.5	4.7	4.4	-	-	-
136	3.2	3.8	4.3	3.8	-	-	-
144	2.9	2.9	3.4	2.7	-	-	-
152	2.1	2.1	2.3	-	-	-	-

<b>137.5 ft</b>							
		26.3 ft		0°		0°	
		62.3 ft		0°		20°	
ft	1,000 lb						
48	7.4	-	-	-	-	-	-
56	7.2	-	-	-	-	-	-
64	6.9	-	-	-	-	-	-
72	6.8	6.8	-	-	-	-	-
80	6.6	6.6	-	6.1	-	-	-
88	6.3	6.3	5.9	5.6	-	-	-
96	6.0	6.0	5.7	5.4	-	-	-
104	5.8	5.8	5.5	5.3	4.4	-	-
112	5.7	5.5	5.3	5.1	4.2	-	-
120	4.8	5.2	5.0	4.8	4.1	-	-
128	4.3	4.8	4.9	4.5	4.0	-	-
136	3.7	4.2	4.7	4.2	3.8	-	-
144	3.1	3.8	3.8	3.4	3.7	-	-
152	2.8	3.0	2.9	2.5	3.2	-	-
160	2.0	2.2	2.0	-	2.2	-	-

<b>39.4 ft</b>							
		26.3 ft		0°		0°	
		62.3 ft		0°		20°	
ft	1,000 lb						
16	15.9	-	-	-	-	-	-
18	15.8	-	-	-	-	-	-
20	15.6	-	-	-	-	-	-
24	14.8	-	-	-	-	-	-
28	14.1	-	-	-	-	-	-
32	13.4	-	-	-	-	-	-
36	12.6	-	-	-	-	-	-
40	11.8	10.7	-	-	-	-	-
48	10.3	9.4	-	8.8	-	-	-
56	9.2	8.5	-	7.8	-	-	-
64	8.2	7.7	7.2	7.2	-	-	-
72	7.3	6.9	6.6	6.4	-	-	-
80	6.7	6.3	6.1	5.9	5.2	-	-
88	6.0	5.8	5.6	5.3	4.8	-	-
96	5.5	5.2	5.4	4.9	4.5	-	-
104	4.9	4.9	-	4.7	4.4	-	-



**22,300 lb**      **26.6 ft x 23.6 ft**      **360°**      **85 %**

**179.5 ft**



ft	26.3 ft	
	0°	0°
1,000 lb	62.3 ft	
	0°	20°
56	2.6	-
64	2.6	-
72	2.6	-
80	2.6	-
88	2.6	-
96	2.1	-

**165.4 ft**



ft	26.3 ft	
	0°	0°
1,000 lb	62.3 ft	
	0°	20°
56	4.4	-
64	4.4	-
72	4.4	-
80	4.4	4.2
88	4.0	4.2
96	3.2	4.2
104	2.2	3.4

**151.6 ft**



ft	26.3 ft			
	0°	0°	0°	20°
1,000 lb	62.3 ft			
	0°	20°	40°	0°
48	6.3	-	-	-
56	6.2	-	-	-
64	6.0	-	-	-
72	5.7	-	-	-
80	5.6	5.7	-	-
88	4.8	5.6	-	5.4
96	4.3	5.1	5.5	5.2
104	3.6	4.3	5.3	4.5
112	2.6	3.2	4.3	3.2
120	-	-	3.1	-

**137.5 ft**



ft	26.3 ft				
	0°	0°	0°	20°	40°
1,000 lb	62.3 ft				
	0°	20°	40°	0°	0°
48	7.4	-	-	-	-
56	7.2	-	-	-	-
64	6.9	-	-	-	-
72	6.8	6.8	-	-	-
80	6.5	6.6	-	6.1	-
88	5.7	6.3	5.9	5.6	-
96	5.2	5.8	5.7	5.4	-
104	4.4	5.3	5.5	5.1	4.4
112	3.7	4.6	5.2	4.1	4.2
120	2.7	3.3	3.9	3.1	4.1
128	1.9	2.4	2.9	2.1	3.4
136	-	-	1.8	-	2.2

**39.4 ft**



ft	26.3 ft				
	0°	0°	0°	20°	40°
1,000 lb	62.3 ft				
	0°	20°	40°	0°	0°
16	15.9	-	-	-	-
18	15.8	-	-	-	-
20	15.6	-	-	-	-
24	14.8	-	-	-	-
28	14.1	-	-	-	-
32	13.4	-	-	-	-
36	12.6	-	-	-	-
40	11.8	10.7	-	-	-
48	10.3	9.4	-	8.8	-
56	9.2	8.5	-	7.8	-
64	8.2	7.7	7.2	7.2	-
72	7.3	6.9	6.6	6.4	-
80	6.7	6.3	6.1	5.9	5.2
88	6.0	5.8	5.6	5.3	4.8
96	5.5	5.2	5.4	4.9	4.5
104	4.9	4.9	-	4.7	4.4

**11,900 lb**      **26.6 ft x 23.6 ft**      **360°**      **85 %**

**179.5 ft**



ft	26.3 ft	
	0°	0°
1,000 lb	62.3 ft	
	0°	20°
56	2.6	-
64	2.6	-
72	2.6	-

**165.4 ft**



ft	26.3 ft	
	0°	0°
1,000 lb	62.3 ft	
	0°	20°
56	4.4	-
64	4.4	-
72	4.4	-
80	3.3	-

**151.6 ft**



ft	26.3 ft			
	0°	0°	0°	20°
1,000 lb	62.3 ft			
	0°	20°	40°	0°
48	6.3	-	-	-
56	6.2	-	-	-
64	6.0	-	-	-
72	5.3	-	-	-
80	4.5	5.5	-	-
88	3.6	4.7	-	-
96	2.3	3.3	-	-
104	-	1.9	-	-

**137.5 ft**



ft	26.3 ft				
	0°	0°	0°	20°	40°
1,000 lb	62.3 ft				
	0°	20°	40°	0°	0°
48	7.4	-	-	-	-
56	7.2	-	-	-	-
64	6.9	-	-	-	-
72	6.4	6.8	-	-	-
80	5.7	6.4	-	6.1	-
88	4.6	5.7	5.9	5.6	-
96	3.5	4.6	5.5	4.5	-
104	2.3	3.3	4.2	3.0	4.4
112	-	-	2.8	-	3.9
120	-	-	-	-	2.6

**39.4 ft**



ft	26.3 ft				
	0°	0°	0°	20°	40°
1,000 lb	62.3 ft				
	0°	20°	40°	0°	0°
16	15.9	-	-	-	-
18	15.8	-	-	-	-
20	15.6	-	-	-	-
24	14.8	-	-	-	-
28	14.1	-	-	-	-
32	13.4	-	-	-	-
36	12.6	-	-	-	-
40	11.8	10.7	-	-	-
48	10.3	9.4	-	8.8	-
56	9.2	8.5	-	7.8	-
64	8.2	7.7	7.2	7.2	-
72	7.3	6.9	6.6	6.4	-
80	6.7	6.3	6.1	5.9	5.2
88	6.0	5.8	5.6	5.3	4.8
96	5.5	5.2	5.4	4.9	4.5
104	4.9	4.9	-	4.7	4.4



57,500 lb		26.6 ft x 23.6 ft												360°		85 %	
ft		39.4 ft	53.5 ft	67.3 ft	81.4 ft	95.5 ft	109.6 ft	123.4 ft	132.5 ft	146.7 ft	163.7 ft	179.1 ft	194.9 ft	ft			
1,000 lb																	
10	58.0	58.0	58.0	-	-	-	-	-	-	-	-	-	-	10			
12	58.0	58.0	58.0	-	-	-	-	-	-	-	-	-	-	12			
14	58.0	58.0	58.0	58.0	-	-	-	-	-	-	-	-	-	14			
16	58.0	58.0	58.0	58.0	-	-	-	-	-	-	-	-	-	16			
18	58.0	58.0	58.0	58.0	58.0	-	-	-	-	-	-	-	-	18			
20	58.0	58.0	58.0	58.0	58.0	58.0	56.0	-	-	-	-	-	-	20			
24	58.0	58.0	58.0	58.0	58.0	58.0	53.5	48.7	-	-	-	-	-	24			
28	58.0	58.0	58.0	58.0	58.0	57.2	51.3	46.7	-	-	-	-	-	28			
32	58.0	58.0	58.0	58.0	58.0	55.1	49.2	43.6	37.2	-	-	-	-	32			
36	-	56.1	56.0	55.8	52.9	47.1	40.7	35.0	30.2	-	-	-	-	36			
40	-	53.1	53.3	52.7	50.1	45.1	38.0	32.8	28.6	23.0	17.9	-	-	40			
48	-	-	42.0	41.5	40.7	40.2	32.9	28.8	25.5	21.6	17.6	12.6	-	48			
56	-	-	33.1	33.9	33.7	32.3	28.5	25.1	22.9	19.8	17.0	12.6	-	56			
64	-	-	-	28.0	27.2	25.9	24.8	22.1	20.2	18.0	16.1	12.6	-	64			
72	-	-	-	23.2	22.4	21.3	21.6	19.9	17.9	16.1	14.8	12.4	-	72			
80	-	-	-	-	18.9	18.9	18.5	17.2	16.2	14.6	13.7	11.6	-	80			
88	-	-	-	-	8.1	16.8	15.6	15.3	13.9	13.4	12.5	11.0	-	88			
96	-	-	-	-	-	14.5	13.6	13.4	12.5	11.8	11.6	10.2	-	96			
104	-	-	-	-	-	7.4	12.5	11.5	11.2	10.7	10.1	9.4	-	104			
112	-	-	-	-	-	-	-	9.9	9.6	9.2	8.6	8.3	-	112			
120	-	-	-	-	-	-	-	9.2	8.4	7.7	7.7	7.0	-	120			
128	-	-	-	-	-	-	-	-	7.5	6.6	6.5	5.7	-	128			
136	-	-	-	-	-	-	-	-	6.4	6.1	5.3	4.7	-	136			
144	-	-	-	-	-	-	-	-	-	5.3	4.4	3.6	-	144			
152	-	-	-	-	-	-	-	-	-	3.6	3.6	2.8	-	152			
160	-	-	-	-	-	-	-	-	-	-	2.9	2.0	-	160			

47,000 lb		26.6 ft x 23.6 ft												360°		85 %	
ft		39.4 ft	53.5 ft	67.3 ft	81.4 ft	95.5 ft	109.6 ft	123.4 ft	132.5 ft	146.7 ft	163.7 ft	179.1 ft	194.9 ft	ft			
1,000 lb																	
10	58.0	58.0	58.0	-	-	-	-	-	-	-	-	-	-	10			
12	58.0	58.0	58.0	-	-	-	-	-	-	-	-	-	-	12			
14	58.0	58.0	58.0	58.0	-	-	-	-	-	-	-	-	-	14			
16	58.0	58.0	58.0	58.0	-	-	-	-	-	-	-	-	-	16			
18	58.0	58.0	58.0	58.0	58.0	-	-	-	-	-	-	-	-	18			
20	58.0	58.0	58.0	58.0	58.0	58.0	56.0	-	-	-	-	-	-	20			
24	58.0	58.0	58.0	58.0	58.0	58.0	53.5	48.7	-	-	-	-	-	24			
28	58.0	58.0	58.0	58.0	58.0	57.2	51.3	46.7	-	-	-	-	-	28			
32	58.0	58.0	58.0	58.0	58.0	55.1	49.2	43.6	37.2	-	-	-	-	32			
36	-	54.3	54.3	54.1	51.7	47.1	40.7	35.0	30.2	-	-	-	-	36			
40	-	49.4	49.6	49.0	47.4	44.8	38.0	32.8	28.6	23.0	17.9	-	-	40			
48	-	-	37.3	37.4	37.9	36.4	32.9	28.8	25.5	21.6	17.6	12.6	-	48			
56	-	-	30.5	30.4	29.7	28.2	27.3	25.1	22.9	19.8	17.0	12.6	-	56			
64	-	-	-	24.6	23.8	22.9	22.8	21.4	20.2	18.0	16.1	12.6	-	64			
72	-	-	-	20.2	19.5	20.3	19.0	18.3	17.3	16.1	14.8	12.4	-	72			
80	-	-	-	-	17.3	17.0	15.8	16.1	15.0	14.3	13.7	11.6	-	80			
88	-	-	-	-	8.1	14.4	14.4	13.5	13.2	12.6	12.1	11.0	-	88			
96	-	-	-	-	-	12.3	12.5	11.7	11.2	10.6	10.2	9.7	-	96			
104	-	-	-	-	-	7.4	10.6	10.3	9.9	8.8	8.8	7.9	-	104			
112	-	-	-	-	-	-	-	8.7	8.3	7.9	7.2	6.5	-	112			
120	-	-	-	-	-	-	-	7.5	7.1	7.0	5.9	5.2	-	120			
128	-	-	-	-	-	-	-	-	6.4	5.7	4.8	4.0	-	128			
136	-	-	-	-	-	-	-	-	5.5	4.8	3.8	3.0	-	136			
144	-	-	-	-	-	-	-	-	-	4.0	2.9	2.2	-	144			
152	-	-	-	-	-	-	-	-	-	2.1	2.1	-	-	152			

		43,700 lb											26.6 ft x 23.6 ft		360°		85 %	
		39.4 ft 53.5 ft 67.3 ft 81.4 ft 95.5 ft 109.6 ft 123.4 ft 132.5 ft 146.7 ft 163.7 ft 179.1 ft 194.9 ft																
		1,000 lb																
ft		ft	ft	ft	ft	ft	ft	ft	ft	ft	ft	ft	ft	ft	ft	ft	ft	
10	58.0	58.0	58.0	-	-	-	-	-	-	-	-	-	-	-	-	-	10	
12	58.0	58.0	58.0	-	-	-	-	-	-	-	-	-	-	-	-	-	12	
14	58.0	58.0	58.0	58.0	-	-	-	-	-	-	-	-	-	-	-	-	14	
16	58.0	58.0	58.0	58.0	-	-	-	-	-	-	-	-	-	-	-	-	16	
18	58.0	58.0	58.0	58.0	58.0	-	-	-	-	-	-	-	-	-	-	-	18	
20	58.0	58.0	58.0	58.0	58.0	58.0	56.0	-	-	-	-	-	-	-	-	-	20	
24	58.0	58.0	58.0	58.0	58.0	58.0	53.5	48.7	-	-	-	-	-	-	-	-	24	
28	58.0	58.0	58.0	58.0	58.0	57.2	51.3	46.7	-	-	-	-	-	-	-	-	28	
32	58.0	58.0	58.0	58.0	58.0	55.1	49.2	43.6	37.2	-	-	-	-	-	-	-	32	
36	-	53.5	53.5	53.2	50.7	47.1	40.7	35.0	30.2	-	-	-	-	-	-	-	36	
40	-	47.7	47.9	47.0	45.5	44.6	38.0	32.8	28.6	23.0	17.9	-	-	-	-	-	40	
48	-	-	35.8	37.0	36.4	35.0	32.6	28.8	25.5	21.6	17.6	12.6	-	-	-	-	48	
56	-	-	29.4	29.2	28.5	27.0	26.5	24.9	22.9	19.8	17.0	12.6	-	-	-	-	56	
64	-	-	-	23.5	22.9	22.5	22.1	20.9	20.0	18.0	16.1	12.6	-	-	-	-	64	
72	-	-	-	19.3	18.8	19.5	18.2	18.3	16.8	16.1	14.8	12.4	-	-	-	-	72	
80	-	-	-	-	17.0	16.3	15.7	15.4	14.7	13.9	13.6	11.6	-	-	-	-	80	
88	-	-	-	-	8.1	13.7	14.0	12.6	12.6	12.2	11.5	10.8	-	-	-	-	88	
96	-	-	-	-	-	12.2	11.8	11.4	10.9	10.1	9.9	9.2	-	-	-	-	96	
104	-	-	-	-	-	7.4	10.0	9.7	9.2	8.7	8.2	7.5	-	-	-	-	104	
112	-	-	-	-	-	-	-	8.3	7.7	7.6	6.8	5.9	-	-	-	-	112	
120	-	-	-	-	-	-	-	7.0	7.0	6.4	5.5	4.6	-	-	-	-	120	
128	-	-	-	-	-	-	-	-	5.9	5.3	4.4	3.5	-	-	-	-	128	
136	-	-	-	-	-	-	-	-	5.0	4.4	3.3	2.6	-	-	-	-	136	
144	-	-	-	-	-	-	-	-	-	3.6	2.5	1.8	-	-	-	-	144	

		15,200 lb											26.6 ft x 23.6 ft		360°		85 %	
		39.4 ft 53.5 ft 67.3 ft 81.4 ft 95.5 ft 109.6 ft 123.4 ft 132.5 ft 146.7 ft 163.7 ft 179.1 ft 194.9 ft																
		1,000 lb																
ft		ft	ft	ft	ft	ft	ft	ft	ft	ft	ft	ft	ft	ft	ft	ft	ft	
10	58.0	58.0	58.0	-	-	-	-	-	-	-	-	-	-	-	-	-	10	
12	58.0	58.0	58.0	-	-	-	-	-	-	-	-	-	-	-	-	-	12	
14	58.0	58.0	58.0	58.0	-	-	-	-	-	-	-	-	-	-	-	-	14	
16	58.0	58.0	58.0	58.0	-	-	-	-	-	-	-	-	-	-	-	-	16	
18	58.0	58.0	58.0	58.0	58.0	-	-	-	-	-	-	-	-	-	-	-	18	
20	58.0	58.0	58.0	58.0	58.0	56.0	-	-	-	-	-	-	-	-	-	-	20	
24	58.0	58.0	58.0	58.0	57.2	53.5	48.7	-	-	-	-	-	-	-	-	-	24	
28	54.3	55.5	55.7	54.7	52.7	49.2	45.5	-	-	-	-	-	-	-	-	-	28	
32	44.3	46.5	46.8	47.1	46.0	41.9	39.3	36.0	-	-	-	-	-	-	-	-	32	
36	-	38.4	39.0	40.3	38.8	36.6	33.6	31.2	29.0	-	-	-	-	-	-	-	36	
40	-	32.3	33.4	33.2	32.3	32.1	30.3	27.6	25.7	22.9	17.9	-	-	-	-	-	40	
48	-	-	24.6	24.5	24.9	24.6	23.9	22.8	20.8	19.4	17.4	12.6	-	-	-	-	48	
56	-	-	18.8	19.6	19.6	19.3	19.0	18.3	17.8	16.1	14.5	12.3	-	-	-	-	56	
64	-	-	-	15.8	15.7	15.8	15.5	14.8	14.0	13.2	11.7	10.1	-	-	-	-	64	
72	-	-	-	12.6	12.9	12.4	12.2	11.7	11.5	10.4	8.9	7.3	-	-	-	-	72	
80	-	-	-	-	10.3	10.0	9.8	9.8	9.1	8.3	6.8	5.2	-	-	-	-	80	
88	-	-	-	-	8.1	8.2	7.7	7.8	7.2	6.4	5.0	3.5	-	-	-	-	88	
96	-	-	-	-	-	6.6	6.1	6.2	5.6	4.8	3.5	2.2	-	-	-	-	96	
104	-	-	-	-	-	5.2	4.8	4.8	4.1	3.5	2.3	-	-	-	-	-	104	
112	-	-	-	-	-	-	-	3.9	3.0	2.4	-	-	-	-	-	-	112	
120	-	-	-	-	-	-	-	2.0	2.2	-	-	-	-	-	-	-	120	

11,900 lb		26.6 ft x 23.6 ft												360°		85 %	
		1,000 lb															
ft	ft	39.4 ft	53.5 ft	67.3 ft	81.4 ft	95.5 ft	109.6 ft	123.4 ft	132.5 ft	146.7 ft	163.7 ft	179.1 ft	194.9 ft	ft	ft		
10	58.0	58.0	58.0	-	-	-	-	-	-	-	-	-	-	10	10		
12	58.0	58.0	58.0	-	-	-	-	-	-	-	-	-	-	12	12		
14	58.0	58.0	58.0	58.0	-	-	-	-	-	-	-	-	-	14	14		
16	58.0	58.0	58.0	58.0	-	-	-	-	-	-	-	-	-	16	16		
18	58.0	58.0	58.0	58.0	58.0	-	-	-	-	-	-	-	-	18	18		
20	58.0	58.0	58.0	58.0	58.0	58.0	56.0	-	-	-	-	-	-	20	20		
24	58.0	58.0	58.0	57.9	56.2	53.2	48.7	-	-	-	-	-	-	24	24		
28	52.8	54.0	54.2	53.1	51.2	47.4	44.1	-	-	-	-	-	-	28	28		
32	41.8	44.0	44.3	45.2	43.5	40.3	36.9	34.4	-	-	-	-	-	32	32		
36	-	36.2	38.1	38.1	36.6	34.8	32.1	30.2	28.0	-	-	-	-	36	36		
40	-	30.6	31.5	31.2	30.8	30.2	28.3	26.9	24.9	22.7	17.9	-	-	40	40		
48	-	-	23.1	23.1	24.0	23.1	22.7	21.2	20.3	18.9	16.9	12.6	-	48	48		
56	-	-	17.7	18.6	18.4	18.6	17.9	17.6	16.5	14.9	13.8	11.6	-	56	56		
64	-	-	-	14.6	14.9	14.6	14.4	13.5	13.4	12.2	10.4	8.8	-	64	64		
72	-	-	-	11.7	11.7	11.5	11.1	11.3	10.6	9.3	7.8	6.2	-	72	72		
80	-	-	-	-	9.4	9.2	8.7	8.9	8.1	7.2	5.7	4.2	-	80	80		
88	-	-	-	-	7.7	7.4	7.0	7.0	6.3	5.5	4.0	2.6	-	88	88		
96	-	-	-	-	-	5.8	5.3	5.5	4.8	4.2	2.6	-	-	96	96		
104	-	-	-	-	-	4.5	4.1	4.1	3.5	2.8	-	-	-	104	104		
112	-	-	-	-	-	-	-	3.2	2.4	-	-	-	-	112	112		

10,400 lb		26.6 ft x 23.6 ft												360°		85 %	
		1,000 lb															
ft	ft	39.4 ft	53.5 ft	67.3 ft	81.4 ft	95.5 ft	109.6 ft	123.4 ft	132.5 ft	146.7 ft	163.7 ft	179.1 ft	194.9 ft	ft	ft		
10	58.0	58.0	58.0	-	-	-	-	-	-	-	-	-	-	10	10		
12	58.0	58.0	58.0	-	-	-	-	-	-	-	-	-	-	12	12		
14	58.0	58.0	58.0	58.0	-	-	-	-	-	-	-	-	-	14	14		
16	58.0	58.0	58.0	58.0	-	-	-	-	-	-	-	-	-	16	16		
18	58.0	58.0	58.0	58.0	58.0	-	-	-	-	-	-	-	-	18	18		
20	58.0	58.0	58.0	58.0	58.0	56.0	-	-	-	-	-	-	-	20	20		
24	58.0	58.0	58.0	57.4	55.8	52.8	48.3	-	-	-	-	-	-	24	24		
28	52.0	53.3	53.4	51.6	50.5	46.0	42.6	-	-	-	-	-	-	28	28		
32	40.4	42.7	43.6	44.2	42.3	39.3	35.7	33.7	-	-	-	-	-	32	32		
36	-	35.1	37.2	37.0	35.6	34.3	31.6	29.3	27.1	-	-	-	-	36	36		
40	-	29.5	30.6	30.4	30.4	29.3	28.0	26.8	24.4	22.4	17.9	-	-	40	40		
48	-	-	22.4	22.9	23.3	22.5	22.5	20.9	20.0	18.2	16.7	12.6	-	48	48		
56	-	-	17.3	18.1	17.7	17.9	17.5	17.0	15.6	14.6	13.2	11.2	-	56	56		
64	-	-	-	14.0	14.4	13.9	13.7	13.1	12.9	11.5	9.7	8.1	-	64	64		
72	-	-	-	11.1	11.3	10.9	10.6	10.6	10.0	8.7	7.1	5.6	-	72	72		
80	-	-	-	-	9.0	8.7	8.3	8.5	7.6	6.8	5.0	3.7	-	80	80		
88	-	-	-	-	7.4	7.0	6.5	6.5	5.8	5.1	3.5	-	-	88	88		
96	-	-	-	-	-	5.5	5.0	5.0	4.4	3.7	2.3	-	-	96	96		
104	-	-	-	-	-	4.3	3.7	3.9	3.2	2.6	-	-	-	104	104		
112	-	-	-	-	-	-	-	2.8	-	-	-	-	-	112	112		

Ratings are in compliance with ASME B30.5.  
Lifting capacities do not exceed 85 % of tipping load.

Weight of hook blocks and slings is part of the load, and is to be deducted from the capacity ratings.  
Consult operation manual for further details.

**Note:** Data published herein is intended as a guide only and shall not be construed to warrant applicability for lifting purposes.  
Crane operation is subject to the computer charts and operation manual both supplied with the crane.

---

**The telescopic loads stated in the capacity chart are valid under the following conditions:**

- The sliding areas of the telescopes must be lubricated well.
- The surroundings temperature has to be normal (considerable reductions must be expected below 0 °C).
- The radius in the chart is given for the end length of the telescopic sequence.
- The capacities are valid for extending and retracting the telescopic section.
- The telescopic loads are only valid for moving the last section of the sequence. The curve for e. g. 0-0-45-90-90 % is only valid for telescoping from 0-0-0-90-90 % to 0-0-45-90-90 % and back, but not for 0-0-0-0-0 % to 0-0-45-90-90 %!
- The telescopic loads are based on the telescoping ability of the boom. The loads to be telescoped must never exceed the loads in the load chart as tipping of the crane may occur.
- The most advantageous individual telescoping sequence is shown. Other telescoping sequences for the same boom length will result in lower lifting capacities for telescoping. Refer to the machine's documentation for these lifting capacity values.

## Basic equipment

### Carrier

Engine 335-3a	MTU; Output 335 kW (455 HP), torque 2000 Nm, certifications in accordance with EUROMOT 3a, TIER 3, CARB; Exhaust system cpl. stainless steel, incl. spark arrester.
Fuel tank 400	106 gallons; Fuel: Diesel.
Transmission AS12INT	ZF AS-Tronic; Automated gearbox with integrated hydraulic retarder, 12 forward speeds and 2 reverse; 2-stage transfer case with switchable off-road gear and switchable longitudinal lock.
Axles 8 x 6 x 8	8 x 6 x 8; 4 Axles, axles 1, 2, 4 driven and equipped with selectable transverse lock; All axles steered.
Suspension	Hydropneumatic suspension with axle load compensation; Hydraulically lockable; Manual or automatic levelling alternatively.
Steering	Dual circuit hydro servocom steering with emergency steering pump; Active rear axle steering (axles 3 and 4) with 6 different steering programs.
Brakes	Pneumatic dual circuit service brake with antilock system, acting on all wheels; Disc brakes; Additional exhaust brake and constant throttle valve; Spring-loaded parking brake.
Wheels 38595 170F	385/95R25 170F (14.00R25); Steel rims 9,50-25/1,7" CR.
Cab carrier 2550	Type 8.4 ft; Adjustable driver seat with seat heating, armrests and pneumatic suspension; Steering wheel height and tilt adjustable; Power door windows; Tinted glass; Air condition and radio preparation; 2 integrated rotary beacons; Storage area.
Heating engine-dependant 12	Engine-dependant warm water heating with 12 kW heating power.
Drive lights	With low beam, upper beam, daytime running lights.
Tempomat	Automatic speed control including automatic brake control.
Electronic immobiliser system	Prevents uncontrolled carrier mobilisation; Incl. 2 electronic keys and 4 ignition keys.
Miscellaneous	Ascendancies; Pneumatic tire filling plug.

### Crane

Telescopic boom HA60	39.4 ft - 194.9 ft; Single cylinder telescoping system, automatic telescoping; Attachments for all equipment and extensions; 5 sheaves integrated in boom head for max. capacity of 145,200 lb.
Counterweight EG21	47,000 lb, 6 pieces; Automatic rigging system; Expandable to max. 57,500 lb; 47,000 lb can be carried on board as standard; 10,400 lb fixed at crane tail.
Outriggers	H-4-Point design; Vertical and horizontal movement fully hydraulic; Manual or automatic levelling alternatively carrier sideways; 4 outrigger bases.
Outrigger pads 028	4 outrigger pads A = 3.01 ft <sup>2</sup> with transport position at vertical cylinder.
Boom luffing	Single luffing cylinder with automatic lowering brake valve.
Rotary drive	Single slewing gear unit with spring-loaded multi-disc brake.
H1	Hoist with spring-loaded multi-disc brake; Resolver (hoist rotation indicator).
Engine 129-3b	MTU; Output 129 kW (175 HP), torque 675 Nm, certifications in accordance with EURO MOT 3a, TIER 3, CARB; Exhaust system cpl. stainless steel, incl. spark arrester.
Fuel tank 200	53 gallons; Fuel: Diesel.
Drive	Hydraulic system with power control; Hydraulic oil cooler.
Control system	Enabling 4 simultaneous working movements; Electric pilot controls via 2 two-axis joysticks.
Operator aids	IC-1, with integrated load moment indicator acc. EN13000; Colour display; Displaying of current operating conditions, load charts, fault indicator; Signal lights indicating LMI-load; Crane data logger.
Working range limiter	Displaying and programmability of the work range limits by IC-1.
Cab crane 0875	Type 2.9 ft; Tilt variable 20°; Seat heating; Fold-out front window; Extendable side and foldable front pedestal; Handrails; Tinted safety glass; Pull-down sun visor and light curtains; Air condition and radio preparation.
Heating engine-dependant 12	Engine-dependant warm water heating with 12 kW heating power.

### Diverse

Illumination	1 x adjustable for work prefield at crane cab, 4 x for outriggers.
Rotary beacons 2	2 x integrated on carrier cab, 2 x disconnectable on crane tail.
Toolkit	Toolkit for light repairs and service.
Contour safety marking	Continuous, yellow reflecting bands at carrier sides and tail.
Stepladder	Loose stepladder for misc assembly work; Incl. transport storage.



## Power train variant

<b>EURO MOT 3b, TIER 4i, CARB Engine 335-3b</b>	For carrier and crane, as explained below; Attention, possible only in accordance with the valid country table. MTU; Output 335 kW (455 HP), torque 2000 Nm, certifications in accordance with EURO MOT 3b, TIER 4i, CARB; MTU exhaust system made of stainless steel with SCR catalyst.
<b>Fuel tank 400-40</b>	106 gallons Diesel; 10.6 gallons Ad-Blue.
<b>Engine 129-3b</b>	MTU; Output 129 kW (175 HP), torque 675 Nm, certifications in accordance with EURO MOT 3b, TIER 4i, CARB; MTU exhaust system made of stainless steel with SCR catalyst.
<b>Fuel tank 200-20</b>	53 gallons Diesel; 5.3 gallons Ad-Blue.

## Options (free configurable)

### Carrier

<b>Axles 8 x 8 x 8</b>	8 x 8 x 8; All 4 axles steered and permanently driven and equipped with selectable transverse lock.
<b>Counterweight „c“ transport storage on carrier tail</b>	Support frame for storing counterweight „c“ à 7,000 lb on carrier tail; Required to carry 22,300 lb, 30,400 lb or 33,700 lb counterweight on board.
<b>Wheels 44595 174F</b>	445/95R25 174F (16.00R25); Steel rims 11,00-25/1,7" CR.
<b>Wheels 52580 179E</b>	525/80R25 179E (20.50R25); Steel rims 17,00-25/1,7" CR; Incl. carrier broadening to 9 ft.
<b>Auxiliary heating engine independant carrier 10</b>	Auxiliary, engine independant Diesel heating system with 10 kW heating power; With timer; Switchable between engine block and carrier cab.
<b>Air condition carrier 7</b>	Air condition for carrier cab with 7 kW cooling power.

### Crane

<b>Remote control RK</b>	Fully-fledged control of rigging and crane work via wireless remote control.
<b>S1V</b>	Heavy lift attachment stage 1; 2-sheave; Dis-/connectable; For total 7 sheaves at boom head and max. capacity of 176,400 lb.
<b>H2X</b>	2. hoist; Spring-loaded multi-disc brake; Resolver (hoist rotation indicator); Incl. quick couplings and transport storage; Self-rigging; Enables 2-hook operation with all extensions.
<b>Counterweight NEG21</b>	Version for countries with special road regulations; Enables self-downrigging < 88,200 lb total weight and axle loads < 26,500 lb; Total 47,200 lb à 7 pieces; Automatic rigging system, expandable to max. 57,500 lb; Individual technical verification required.
<b>Additional counterweight EG</b>	10,600 lb, 2 pieces; For max. 57,500 lb à 8 pieces; Only in combination with counterweight EG21.
<b>Additional counterweight NEG</b>	10,400 lb, 1 piece; For max. 57,500 lb à 8 pieces; Only in combination with counterweight NEG21.
<b>Quick connection HA 2</b>	Hydraulic bolt extractors and hydraulic and electric quick couplings for fast (dis-) assembly; Incl. transport storage for luffing cylinder.
<b>Outrigger load indicator</b>	Displayed in LMI crane cab.
<b>Outrigger basis monitoring</b>	Surveillance of each outrigger beam for visual comparison with the programmed outrigger basis; Displayed in LMI crane cab (Attention – there is no automatic linkage with the LMI system).
<b>Moving out of crane cab</b>	Control of carrier out of crane cab, enables machine moving when rigged, possible even under load.
<b>Auxiliary heating engine independant crane 5</b>	Auxiliary, engine independant Diesel heating system with 5 kW heating power; With timer and remote start; Switchable between engine block and carrier cab.
<b>Air condition crane 7</b>	Air condition in crane cab with 7 kW cooling power.

### Extensions

<b>HAV19</b>	32.8 ft / 62.3 ft; Double folding swing-away jib, manual offset 20° / 40°; 1-sheave head; Incl. transport storage; Includes HAV10; Operation with HA or VA.
<b>HAV-HY</b>	Hydraulic, stepless offset 0°-40°, instead of the manual offset; For HAV10, respectively HAV19.
<b>VA8</b>	26.2 ft; Variable telescopic boom extension, manual offset 20° / 40°; Operation with HAV(-HY)19.
<b>MSF2</b>	4.9 ft; Fixed assembly jib, 2-sheave for max. capacity 58,000 lb; Incl. transport storage at boom head.
<b>R1</b>	Swing-away rooster sheave; Incl. transport storage; For single-reeving operation with elevated hook height.

### Diverse

<b>Refinery package 2M</b>	Engine emergency stop device, with air shut-off damper, for carrier and crane.
<b>Dolly preparation 4PV</b>	4-point support brackets enable individual positioning of a dolly; Incl. freewheel for slewing gear unit and luffing cylinder, quick couplings for brake air and electrics; Dolly and dollyadapter are not included.
<b>Hook block 100-7-18-D</b>	100-7-18-D (1,650 lb); Hook block with ramshorn hook; white with red signal stripes.
<b>Hook block 80-5-18-D</b>	80-5-18-D (1,430 lb); Hook block with ramshorn hook; white with red signal stripes.
<b>Hook block 80-5-18-E</b>	80-5-18-E (1,430 lb); Hook block with single hook; white with red signal stripes.
<b>Hook block 50-3-18-D</b>	50-3-18-D (1,210 lb); Hook block with ramshorn hook; white with red signal stripes.
<b>Hook block 50-3-18-E</b>	50-3-18-E (1,210 lb); Hook block with single hook; white with red signal stripes.
<b>Hook block 20-1-18-E</b>	20-1-18-E (662 lb); Hook block with single hook; white with red signal stripes.
<b>Hook 8-0-18-E</b>	8-0-18-E (374 lb); Single hook; red.

[www.terexcranes.com](http://www.terexcranes.com)

Effective Date: March 2011.

Product specifications and prices are subject to change without notice or obligation. The photographs and/or drawings in this document are for illustrative purposes only. Refer to the appropriate Operator's Manual for instructions on the proper use of this equipment. Failure to follow the appropriate Operator's Manual when using our equipment or to otherwise act irresponsibly may result in serious injury or death. The only warranty applicable to our equipment is the standard written warranty applicable to the particular product and sale and Terex makes no other warranty, express or implied. Products and services listed may be trademarks, service marks or trade-names of Terex Corporation and/or its subsidiaries in the USA and other countries. All rights are reserved. Terex<sup>®</sup> is a registered trademark of Terex Corporation in the USA and many other countries.

Copyright 2011 Terex Corporation

Terex Cranes, Global Marketing, Dinglerstraße 24, 66482 Zweibrücken, Germany  
Tel. +49 (0) 6332 830, Email: [info.cranes@terex.com](mailto:info.cranes@terex.com), [www.terexcranes.com](http://www.terexcranes.com)

Brochure Reference: TC-DS-I-E-AC 100/4L-03/11



**WORKS FOR YOU.™**