



TEREX®

AL4000

Light Towers

LIGHT TOWER
AL4000



Features

- 30 ft (9.14 m) light height at full extension for excellent illumination at long distances.
- 359 degree non-continuous tower rotation to provide pin-point light positioning at your work site.
- Self-braking, erecting and extending hand-operated winch with self-lubricating steel cable is mounted inside the cabinet.
- Light fixtures mount securely on mast for travel or can be left on crossarm.
- Individual quick-connect plug-in ballasts installed in galvanized steel boxes.
- Light fixtures plug into weatherproof receptacle box with UL and CSA approved connectors.
- Retractable power cord automatically recoils into protective sleeve to prevent damage when raising, lowering and moving tower.
- Control panel located inside cabinet, protected from the elements.
- Single point lifting eye and forklift pockets provided for easy loading and unloading.

Light Towers AL4000

Specifications

Lamps	Metal halide 4 x 1,000 W
Generator	Brushless 60 Hz, 6.0 kW
Engine	Kubota diesel 13.6 hp
Receptacles	One GFI duplex 20 A / 120 V One T/L 30 A / 240 V
Fuel capacity	30 gal (114 L)
Wheel size	15 in (38 cm)
Axle rating	3,500 lbs (1,558 kg)
Tongue weight travel position	147 lbs (67 kg)
Total weight no fuel	1,950 lbs (885 kg)

Notice: Metal halide lamp bulbs contain mercury (Hg).
Dispose of lamp bulbs according to local, state and federal laws.

Options and Accessories

12 Volt dome light with switch
3/8" highway safety chain with snap hook
4 horizontally mounted lights, cast aluminum square housing
50 hz, 7 kW generator, 13.6 hp Kubota engine
50 gal fuel capacity
60 hz, 8 kW generator, 13.6 hp Kubota engine
60 hz, 6 kW generator, Perkins Tier IV 13.8 hp
700 CCA battery
Battery heater blanket
Block heater
Combination ring/ball hitch
DOT tail light package (6 or 7 pole)
Electric trailer brakes
Export racking/preparation
Fuel/water separator filter
Fuel/water separator with fuel line heater
Hydraulic surge brakes (ring or ball hitch)
Low temperature coolant mixture (-40 deg F)
Ring hitch 2.5"
Roda Deaco air shutdown system
Spare tire/wheel

Dimensions

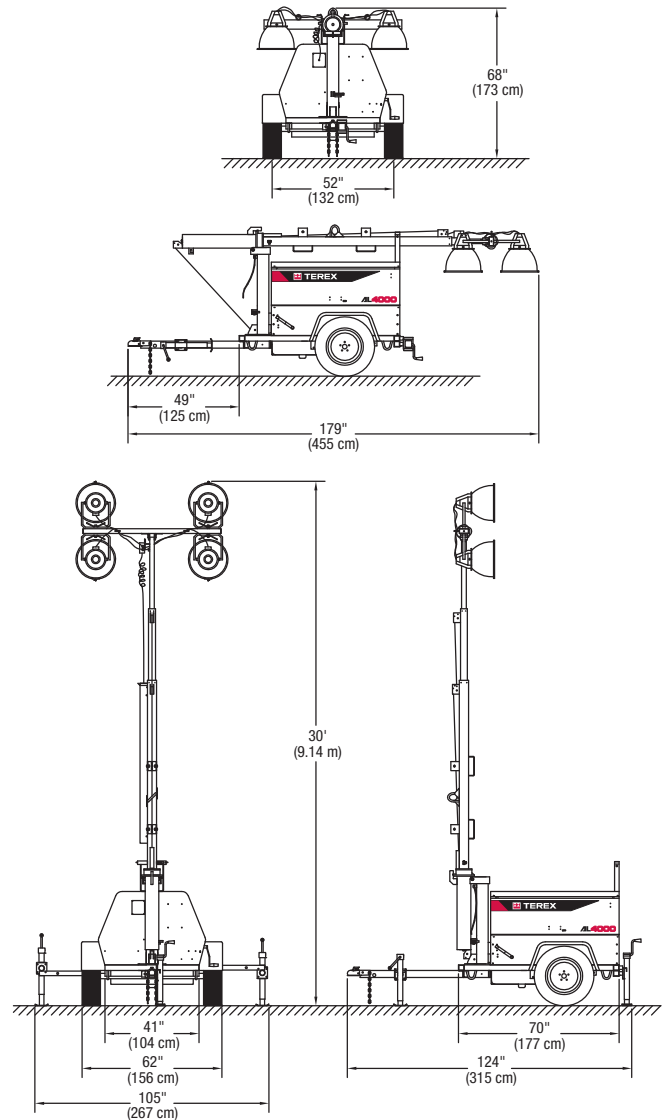

Terex Aerial Work Platforms

18340 NE 76th Street
PO Box 97030
Redmond, WA 98073-9730

TEL +1 (425) 881-1800
TOLL FREE +1 (800) 536-1800
PARTS & TECH SUPPORT +1 (800) 228-6444
FAX +1 (425) 883-3475
WEB www.genieindustries.com

For more information, product demonstration, or details on purchase, lease and rental plans, please contact your local Terex AWP distributor.

Effective Date: April, 2011. Product specifications and prices are subject to change without notice or obligation. The photographs and/or drawings in this document are for illustrative purposes only. Refer to the appropriate Operator's Manual for instructions on the proper use of this equipment. Failure to follow the appropriate Operator's Manual when using our equipment or to otherwise act irresponsibly may result in serious injury or death. The only warranty applicable to our equipment is the standard written warranty applicable to the particular product and sale and we make no other warranty, express or implied. Products and services listed may be trademarks, service marks or trade-names of Terex Corporation, Genie Industries, Inc. and/or their subsidiaries in the U.S.A. and many other countries. All rights are reserved. Terex® is a registered trademark of Terex Corporation in the U.S.A. and many other countries. Genie® is a registered trademark of Genie Industries, Inc. in the U.S.A. and many other countries. Genie is a Terex Brand. © 2011 Terex Corporation. AL4000 0210G Part # 109045