

TEREX
LIGHT CONSTRUCTION

SERIES AL4000
LIGHT TOWER
OPERATION & SERVICE MANUAL

amida
COLEMAN
Engineering

Bartell
morrison[™]

Benford
MULLER

PO Box 3147 • Rock Hill, SC 29732 USA • Phone 803-324-3011

Toll Free 800-433-3026

Parts Department Fax 800-633-5534

TABLE OF CONTENTS

Receiving and Set-up

Safety Precautions	4-6
Check Out on Receipt/Delivery	7
TEREX Amida Light Tower Model Coding System	8
Recommended Engine Oil	9

Operating Instructions

Light Tower Operating Instructions	10-13
Criteria for Replacement of Wire Rope	14-15
Engine (see manufacturer's handbook)	
Generator (see manufacturer's handbook)	

Parts Identification Drawings

Trailer and Related Parts	17-18
Axle and Wheels	19
Cabinet and Attachments	20-22
Tower and Related Parts	23-31
Engine and Generator (Kubota / Alpha)	32-40
Electrical Box	41
Floodlight Fixtures / Ballasts	42-43
Hitches	44
Electric Winch	45
Running Lights	46

Wiring Diagrams

Fixture with Joy Connector (MH or TH)	47
Metal Halide Ballast with Joy Connector	48
High Pressure Sodium Ballast with Joy Connector	49
AC Wiring	50
DC Wiring	51

Troubleshooting Guide

Specifications, Routine Maintenance, Wind Loading	52-55
Broken Cable Replacement Procedure	56-57
Light Fixture Troubleshooting	58-60
TEREX Amida Numbered Wiring System	61
Generator Bearing Inspection	62
Engine (refer to manufacturer's handbook)	
Generator (refer to manufacturer's handbook).....	63-72

Warranty Information

Warranty Procedure.....	73
Warranty.....	74

OPERATOR'S MANUAL

SAFETY PRECAUTIONS

The following symbols in this manual signal potentially dangerous conditions to the operator or equipment. Read this manual carefully. Know when unsafe conditions can exist. Then, take necessary steps to protect personnel, as well as equipment.

WARNING: TEREX Amida uses this symbol throughout this manual to warn of possible fatal injury.

CAUTION: TEREX Amida uses this symbol to point out potential damage to equipment.

Lamps, fuels, electrical equipment, batteries, exhaust gases, loose fasteners, and moving parts present potential hazards that could result in serious personal injury. Be diligent in following the procedures recommended below. Also, observe the many additional general safety rules practiced by trained operation and maintenance personnel in your company and industry. **CAUTION: Always wear a hard hat when operating the light tower!**

- **Guard Against Electrical Shock**

This light tower also has provisions for producing high voltage electricity (up to 480 volts) that can produce a fatal shock to a person who accidentally places their self in the electrical circuit.

Use every precaution to avoid contact with the high voltage electric circuit.

Beware of a cut or damaged power cord. Replace immediately.

Take extra precautions when troubleshooting electrical problems:

- When troubleshooting indicates a malfunction in the high voltage AC system, then pass the troubleshooting task on to a qualified and trained electrician.
- Disconnect electrical power and turn off engine before removing protective covers on high voltage enclosures.
- Understand that the electrical circuits in this light tower complete their paths back to the generator within the equipment. The neutral conductor at the generator is bonded to the equipment frame.
- Ground wires within the system are also bonded to the equipment frame.
- Only use a multimeter (or voltmeter) with two well-insulated probes rated for 750 volts.
- Keep one hand in your pocket when touching the multimeter probe to hot conductors. This will prevent electricity from passing into one hand and out the other, a path that takes the electricity across the heart. Always disconnect power from the circuit being measured before connecting test leads to high voltage points.
- Do not try to position both probes at once. Instead, clamp the common insulated alligator clip to a neutral wire and then probe for voltages with the other probe.
- Never clamp to a hot wire since a severe shock could be received by contact with the other probe.
- Do not use a multimeter with leads or probes that have damaged insulation.
- Inspect the ground cable between the generator set and the frame. If damaged, replace immediately.
- Treat all conductors as potentially hot, especially when troubleshooting malfunctioning equipment. Jewelry should be removed before working around live conductors.
- Proceed through the circuitry systematically, operating only one section at a time.
- Use tools with insulated handles when working within the reach of live conductors.
- Maintain a good footing. If you slip, or a tool drops, do not grab for it if live conductors are within reach.
- Concentrate on the task until the danger from high voltage is removed.

- **Guard Against Battery Hazards**

Lead acid batteries can be dangerous. The sulfuric acid in the battery can cause severe skin and eye burns. The hydrogen gas emitted during charging can explode if an arc or flame is present near the battery. Use precautions to prevent acid burns or explosive conditions.

Do not smoke while servicing batteries.

Do not allow tools to touch battery terminals and create an arc. Do not test battery voltage by setting up a brief arc at the terminals. Use a multimeter instead.

Disconnect the negative terminal of the battery when working on the engine or other parts to prevent accidental arcing. Disconnect the negative cable at the end away from the battery.

Always wear eye protection when servicing the battery.

When charging the battery, do not remove the vent caps.

If acid does get on skin or in eyes, immediately flush under running water, and then obtain medical help as soon as possible.

- **Guard Against Fire Hazard**

Use caution with diesel fuel and motor oil because of fire hazards.

Do not fill fuel tank while engine is running.

Do not smoke or use open flame near the unit or the fuel tank.

Be sure the fuel supply has a positive shut-off valve.

Do not replace fuel lines with materials different from those supplied as original equipment.

Have a fire extinguisher nearby. Be sure the extinguisher is properly maintained and be familiar with its proper use. Extinguishers rated ABC by the NFPA are appropriate for all applications.

Keep this unit clean of excessive build-up of spilled oil and fuel. Accumulated oil and fuel can cause overheating and subsequent engine damage as well as present a fire hazard.

Remember that **EXHAUST GASES ARE TOXIC. WARNING: DO NOT USE INDOORS** unless properly ventilated. Provide an adequate exhaust system to properly expel discharged gases. Check exhaust system regularly for leaks. Ensure periodically that the exhaust manifolds are secure and not warped. Make sure the unit is well ventilated.

- **Protect The Environment And Practice Good Industrial Hygiene**

Prevent pollution by catching used oil in a container for proper disposal.

Wash hands to remove oil and fuel. Practice good industrial hygiene.

Maintain an adequate exhaust system to properly expel discharged gases. Check the exhaust system regularly for leaks.

- **Do Not Touch Hot Parts**

The exhaust manifold and tailpipe are very hot. Parts of the engine are also hot. Avoid touching hot parts of the engine or tailpipe. Use protective gloves when handling hot parts.

- **Be Alert And Attentive To The Task**

Read the safety instructions and operating procedures before attempting to troubleshoot or work on this unit. Also read the engine manual, which is a separate booklet that is provided with this manual.

Do not work on this equipment when mentally or physically fatigued.

Do not work on this equipment when under the influence of performance impairing drugs or alcohol.

If this manual becomes lost, order a new one from TEREX-Amida so future operation and maintenance personnel may read these instructions.

- **Beware of Moving Parts**

Avoid being hit or pinched by the moving parts of this unit.

Loose jackets, shirts, neckties, or sleeves should not be worn while working or running a unit.

Only remove guards or protective devices from unit temporarily to gain access for maintenance. Always replace guards and protective devices promptly.

Keep your hands away from moving parts. Particularly, be sure to keep hands clear of the blower and alternator belts when the engine is running.

- **Beware of Traffic Hazards**

Stand clear of traffic when starting or checking the unit along the road.

Check the fuel tank, oil pan, and fuel and oil lines for leaks that would spill fuel or oil on the road.

Check fasteners and mounting brackets periodically to insure all are tight and nothing is in danger of falling off during transit.

- **Use Only Equal Replacement Parts**

When a part fails and needs to be replaced only use equivalent size, length, thread, grade, and material. Replace stainless steel fasteners with stainless steel fasteners. The engine may use metric or SAE bolts, but all other bolts are generally SAE thread. Be sure to use Grade 8 bolts and nuts to mount the genset to the trailer.

Replace the fuel and oil hoses with items of equal material, diameter and length.

Contact the manufacturer, TEREX-Amida, regarding replacement parts to ensure a correct repair.

- **Use Caution Working Near Lamps**

Metal halide lamps produce short wave ultra-violet radiation and can cause serious skin burn, or eye inflammation if the outer envelope of the lamp is broken or punctured. Do not use where people will remain for more than a few minutes unless adequate shielding or other safety precautions are used.

CHECK OUT ON RECEIPT OF DELIVERY:

The tower will be serviced, tested and ready for operation when received except for export units and skid mount units which are knocked down for shipping (export units are also shipped with dry batteries). Amida recommends the following checks:

- A. INSURE THERE IS NO FREIGHT HANDLING DAMAGE which should be charged against the carrier.
- B. Insure the manuals are in the pocket provided inside the unit.
- C. Review the manuals for safety and operating procedures.
- D. Check the engine oil, coolant (if liquid cooled) and fuel levels.
- E. Operate the tower in accordance with operating instructions.

EXPORT: Assemble according to the instructions enclosed.

LIGHT TOWER MODEL CODING SYSTEM

IMPORTANT

WHEN REQUESTING TECHNICAL HELP AND ORDERING REPLACEMENT PARTS THE MODEL AND SERIAL NUMBER ARE NECESSARY.

REFER TO THE AMIDA SERIAL NUMBER TAG ON THE UNIT FOR CORRECT MODEL NUMBER AND SERIAL NUMBER.

MODEL NUMBER IDENTIFICATION

Sample:

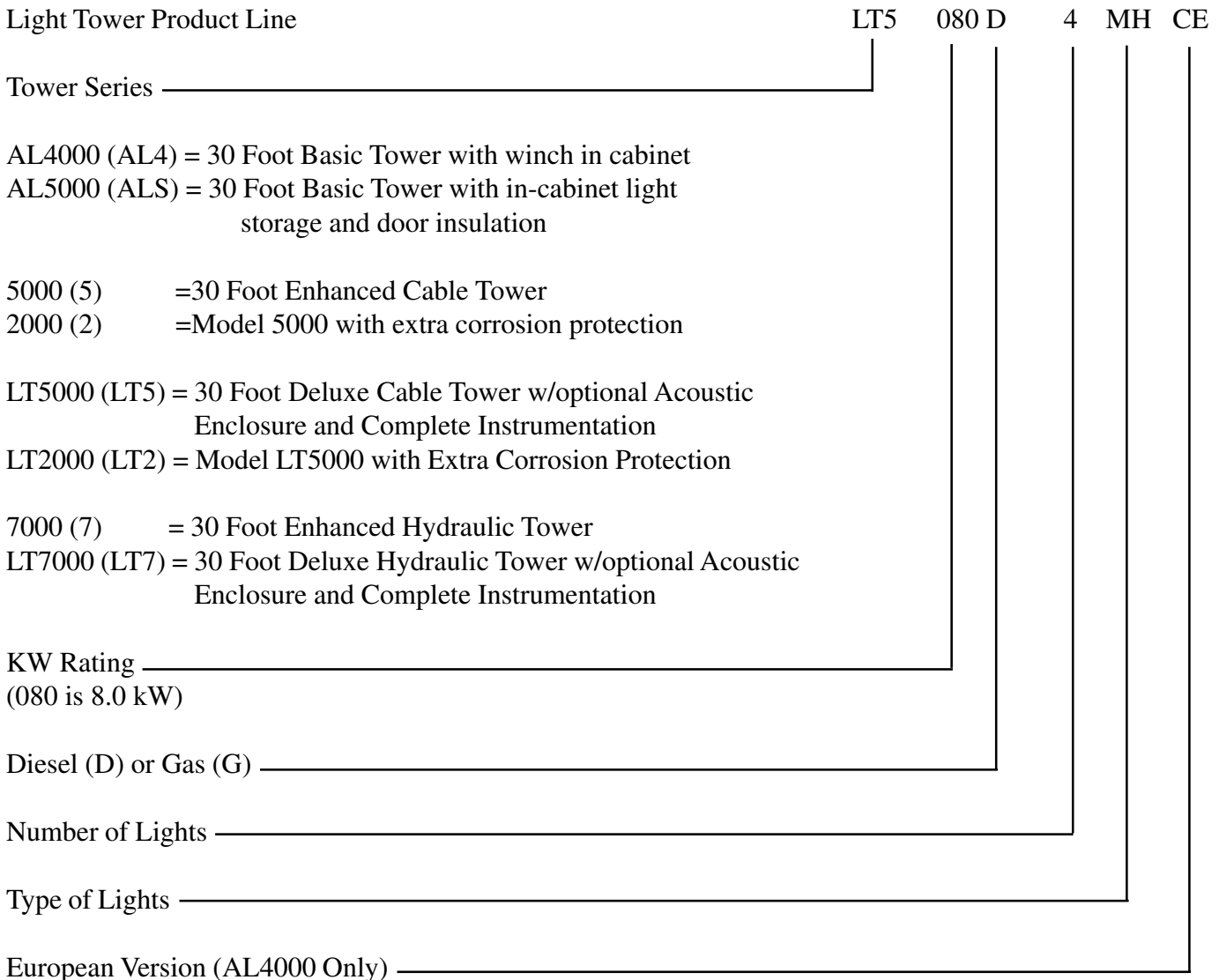

HPS = High Pressure Sodium
MH= Metal Halide
MV= Mercury Vapor
TH= Tungsten Halogen

RECOMMENDED ENGINE OIL & FUEL

KUBOTA D905 DIESEL ENGINE

Engine oil should be MIL-L-2104B/MIL-L-2104C or have properties of API designation of CC/SF or CD/SF. Change the type of engine oil according to the ambient operating temperature:

Above 86°F	SAE 30
32°F to 77°F	SAE20
Below 32°F	SAE10
	SAE 10W-30

Use #2 diesel fuel.

LISTER-PETTER LPW3/LPA3/LPW4/LPWT4 DIESEL ENGINES

Engine oil should be MIL-L-2104C or have properties of API designation of CC/SF or CD/SF. Use CC grade oil for the initial break-in period. Multi-viscosity oils (such as 10W-40) should not be used at temperatures above 32°F. Be sure to use the correct oil viscosity for the weather you are experiencing. When this engine left the factory, it was filled with engine oil as specified on this page.

Change the type of engine oil according to the ambient operating temperature:

86°F and warmer	SAE30
Between 39°F & 86°F	SAE20/20W-SAE 15W/40
Between 5°F & 39°F	SAE 10W
Below 5°F	SAE 5W

Use #2 diesel fuel above 5°F, #1 diesel fuel below 5°F.

NOTES:

1. The temperatures in the table are the ambient temperature at the time when the engine is started. However, if the running ambient temperatures are much higher than the starting temperatures, a compromise must be struck and a higher viscosity oil and fuel used, provided they have a suitable specification.
2. MIL-L-2104B or MIL-L-2104C or API CD oils are recommended, particularly in high temperature applications. They must also be used if the sulfur content of the fuel exceeds 0.5%.
3. **CAUTION:** The use of Series III oils in new, or overhauled naturally aspirated engines can inhibit break-in and give rise to cylinder bore glazing in engines on low duty cycles. Therefore, they should not be used for the first fill in new or newly overhauled naturally aspirated engines, but may be used advantageously after the first 250 hours, when the engine is operating in hot ambient temperatures and high load factor.
4. Always use a reputable brand of diesel fuel. The sulfur content should be below 0.5% (higher sulfur content would require more frequent oil changes). At low ambient temperatures (below freezing), use winter grade diesel fuel. At higher temperatures, use summer grade diesel fuel. Observe strict cleanliness when filling the fuel tank.
5. Check the engine oil level before starting the engine or more than five minutes after it has been stopped. Remove the dipstick, wipe clean, reinsert it, take it out again, and check the oil level. If the oil level is too low, remove the oil plug and add new oil to the FULL line on the dipstick.

MODEL AL4000

OPERATING INSTRUCTIONS

**IMPORTANT: READ ALL DIRECTIONS IN MANUAL CAREFULLY
BEFORE OPERATING EQUIPMENT**

**WARNING CAUTION DO NOT RAISE TOWER IN THE VICINITY OF
OVERHEAD POWER LINES!**

OPERATING INSTRUCTIONS

I. MOVE LIGHT TOWER TO DESIRED LOCATION KEEPING THE FOLLOWING IN MIND:

- A. The light tower should not be placed where those working under the light are either:
 - 1) Forced to look into the light regularly.
 - 2) Forced to work with their backs to the light (shadows will block the light from the work area).
- B. The area where the tower is positioned should be relatively level.
- C. The light tower should be located on the same level or on ground higher than the area being lighted (higher light mounting heights reduce the shadow length).
- D. Unit should be level to ensure smooth trouble-free tower telescoping. Tower may not telescope down properly when unit is not level.

II. UNHITCH FROM THE TOWING VEHICLE AS FOLLOWS:

- A. Engage the trailer braking system, especially if trailer is not on level ground. **CAUTION:** If electrical or manual braking system is not supplied, chock the wheels instead.
- B. Swing the tongue jack into position and raise the tongue off the towing vehicle.

III. LEVEL THE TRAILER, USING THE JACKS AS FOLLOWS:

- A. Extend the rear outriggers until the springs lock into place. Swing the jack on each outrigger into vertical position.
- B. Start at the highest jack position. Rotate the jack handle until the jack foot touches the ground.
- C. Raise the other jacks to level trailer...**WARNING...CAUTION...**insure that the rear jacks are down to prevent the tower from tipping over backwards when raised.

IV. DRIVE GROUNDING ROD INTO EARTH

IV. INSTALL THE FLOODLIGHTS ON THE CROSSBEAM

- A. Remove the light fixtures from the tower by removing detent pin and rotating the clamp to free the lights. Install them on the cross arm studs with the lens facing the ground.
- B. The cord on the fixture should be on the side closest to the trailer so the cord entry is beneath the fixture when the tower is raised (this reduces moisture problems and ensures the water weep hole in the fixture is down).
- C. Set the vertical aim for each light fixture by adjusting the light fixtures and tightening the lower bolt.
- D. Set the spread between the light fixtures horizontal aiming by adjusting the fixtures and tightening the wing nut.
- E. The unit may be transported with the light fixtures mounted on the cross-arm if they are pointed toward the ground.

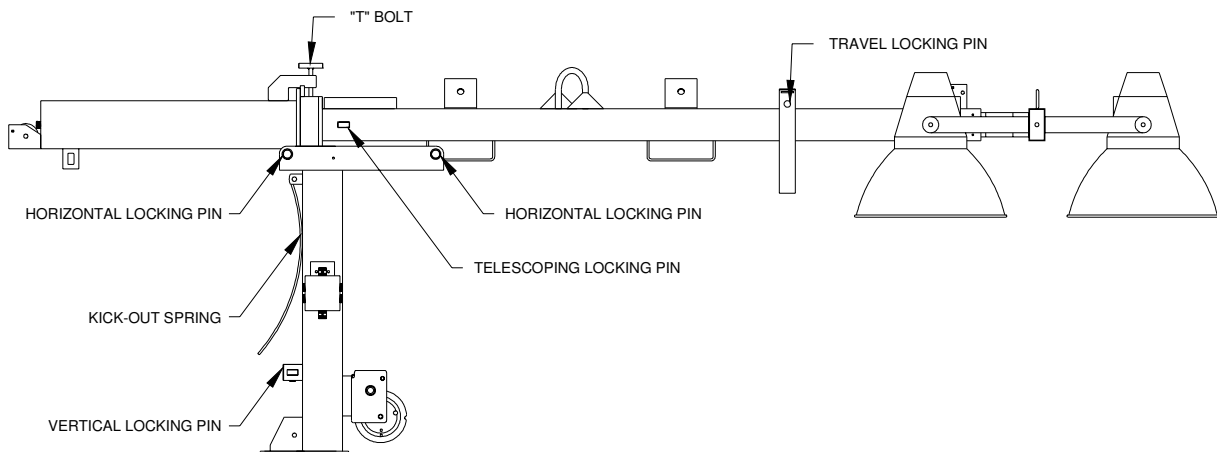

V. RAISING THE TOWER (refer to drawing above)

- A. Remove the tower travel-locking pin from the cradle at the rear of the cabinet.
- B. Aim the fixture, both horizontally and vertically, to the estimated angles that will light the work area.
- C. Using the winch, raise the tower to the vertical position. The tower-locking pin at the base of the pivot post will lock automatically and you will hear it “snap” into place. Insert manual pin into locking device.
- D. Release the tension on the cable by backing the winch off slightly and pull the telescoping locking pin on the galvanized tower section. Hold this out while turning the winch to raise the tower. After the tower has telescoped slightly, the locking pin can be released. Raise the tower to the desired height.

CAUTION: DO NOT ATTEMPT TO LEAN THE TOWER DOWN BELOW 45° WHEN IT IS EXTENDED-SERIOUS DAMAGE MAY OCCUR!

IV. START THE ENGINE / GENERATOR SET

- A. **CAUTION:** Ensure the circuit breakers are turned “OFF”. This prevents the engine from starting under load and prevents electrical equipment from being subjected to improper voltage and frequency.
- B. Check the oil, fuel, and coolant (if liquid cooled) levels. If the fuel tank is empty, it may be necessary to bleed the fuel line after filling the tank (see engine instruction book for procedure).
- C. Turn the ignition switch to the “RUN” position (see diagram below). Press the preheat push button for a **maximum of 7 seconds**. Do not engage the preheat button longer than the time specified or damage may occur.
- D. Turn the ignition switch to the “START” position to engage the engine. After the engine starts, release the switch so that it returns to the “RUN” position. Let the engine come up to speed and stabilize (review the engine operating procedures in the manufacturer’s handbook).
- E. Turn on the main circuit breaker.

V. TURN ON THE FLOODLIGHTS

- A. Turn the circuit breakers “ON” and check to insure all lamps come on. Allow a minimum of two (2) minutes for lamps to reach full luminance.
- B. If required, rotate the tower to aim the lights as desired. Tighten the tower rotating locking bolt.
- C. Adjust the tower vertically and adjust lighting direction of individual fixtures if required.

VI. LOWERING THE TOWER TO TRAVELING POSITION

- A. Loosen rotating lock.
- B. Using the winch, telescope the tower down to its fully retracted position until the telescoping locking pin snaps into place.
- C. Insert manual locking device.
- D. **CAUTION:** Ensure that the telescoping locking pin locks before pulling the tower locking pin at the bottom of the pivot post. This ensures the tower is completely lowered and cannot be damaged by telescoping out while in the travel position.
- E. Rotate the tower so that the groove in the galvanized ring at the pivot is pointing to the rear of the trailer so that the tower can be lowered into the travel position.

Operating Procedures (cont'd)

- F. Pull the vertical locking-pin at the base of the pivot post (the kick-out spring should provide sufficient pressure to start the tower pivoting over).
- G. Let out on the winch cable to lower the tower into the cradle.
- H. Insert the rear tower horizontal travel-locking pin into the cradle.

VII. TURN OFF FLOODLIGHTS

- A. If operating, turn light circuit breakers off.
- B. Turn engine switch to “OFF” to shut down the engine.
CAUTION: Do not shut down engine prior to turning lights off.
- C. **CAUTION:** Allow lamps to cool at least ten (10) minutes before moving the tower to avoid breaking lamps.

VIII. RELOCATING LIGHT TOWER TO NEW LOCATION

- A. Insure that tower has been properly lowered (see section VI) and locking pins are engaged.
- B. Insure all fixtures are pointed toward the ground, or mounted on the fixture storage brackets on the lower tower section.
- C. **CAUTION:** All jacks must be raised and all outriggers locked into travel position.
- D. Insure that the coupler is properly secured to the towing vehicle and attached safety chains (if supplied). Release any manual braking mechanism (if supplied).
- E. Do not tow at excessive speeds (60 mph – 100-kmh maximum) as the weight of the light tower can cause loss of vehicle control, especially under emergency stopping conditions. The standard trailer has no towing brakes; therefore allow extra distance for stopping.

VI. USE OF LIGHT TOWER AUXILIARY POWER

- A. One (1) 30amp/240v Twist-Lock and (1) 15 amp/120v receptacles are provided for auxiliary power.
- B. Total auxiliary power cannot exceed main circuit breaker rating. Each lamp operating consumes 10 amps of current @ 120 volts ac.
- C. Before plugging in auxiliary power cords, feed them up through the trailer frame and attach to receptacles. Close the cabinet doors to protect control panel and other components from weather (see Miscellaneous Specifications and Routine Maintenance section for power control details).

CRITERIA FOR REPLACEMENT OF WIRE ROPE – TEREX-AMIDA LIGHT TOWERS

The wire ropes used to raise and lower the masts on a TEREX-Amida Light Tower are probably some of the most important mechanical parts used in day-to-day operation of the machinery. It is therefore very important that the cables be inspected on a frequent basis (once a month) for wear and tear, and immediately in the event of possible damage due to operator error in using the winch, or possible damage from other equipment.

NORMAL WEAR AND TEAR

When used properly, the wire ropes should give years of trouble-free service, depending on how often the masts are raised and lowered. The rule of thumb at TEREX-Amida is that if the tower is **raised and lowered an average of once per day**, that the cables **should be replaced every two years of service**.

NORMAL INSPECTION

The wire ropes are constructed of 7 strands of 19 plow steel wires each twisted together, and then the assembly galvanized to resist corrosion. Using a wadded-up cloth or heavy leather gloves (to avoid being pricked by a broken wire), run a hand up and down a length of the cable. If any exterior wires are broken, they will lift up from main body of the cable and become visible. For any given 1 foot of cable length; if there are 4 or more wires each, on any 2 or more strands broken, the suspect rope **should be replaced immediately**.

OPERATOR ERROR – OTHER MACHINERY DAMAGE

One of the most common reasons for failure of a Light Tower wire rope is due to operator error in using the winch, or damage to the cable by tools or other machinery. The most common operator error happens when the mast is telescoping down. **When the upper telescoping lock engages, the operator does not pull the lower pivot lock out (located on the tower base) and keeps on cranking the winch. This results in the cable becoming loose around the drum due to the tower not pivoting down.** This can result in three problems: the loose cable can get trapped underneath itself, resulting in a sudden or partial “drop” of the mast when the loose section releases at a later time, thus damaging the cable; or the cable can jump off the winch drum and be damaged by the gears of the winch. The loose cable can also cause the drum to spin to take up the slack cable. If there is enough friction in the threaded parts of the winch, the drum can cause the crank handle to start spinning. This can cause the tower to “freefall” and the results can be catastrophic for anyone standing underneath the tower. A spinning crank handle can also break bones. Other reasons damage can occur are due to some outside force such as forklift blade nicking or crushing a cable when moving a unit, or an accidental blow or damage by a hand tool, etc.

DAMAGE INSPECTION

If any nicks (partial strand cut through), kinks (permanent bends), or weld spatter on the cable (from field service) are observed, the suspect wire rope **should be changed immediately**.

If there is a crushed spot somewhere on the wire rope, it should be **replaced only** if the width of the crushed spot exceeds 1-1/4 times the nominal diameter of the cable (5/16” on a 1/4” cable, and 7/32” on a 3/16” cable), or if there are broken wires at the point of damage.

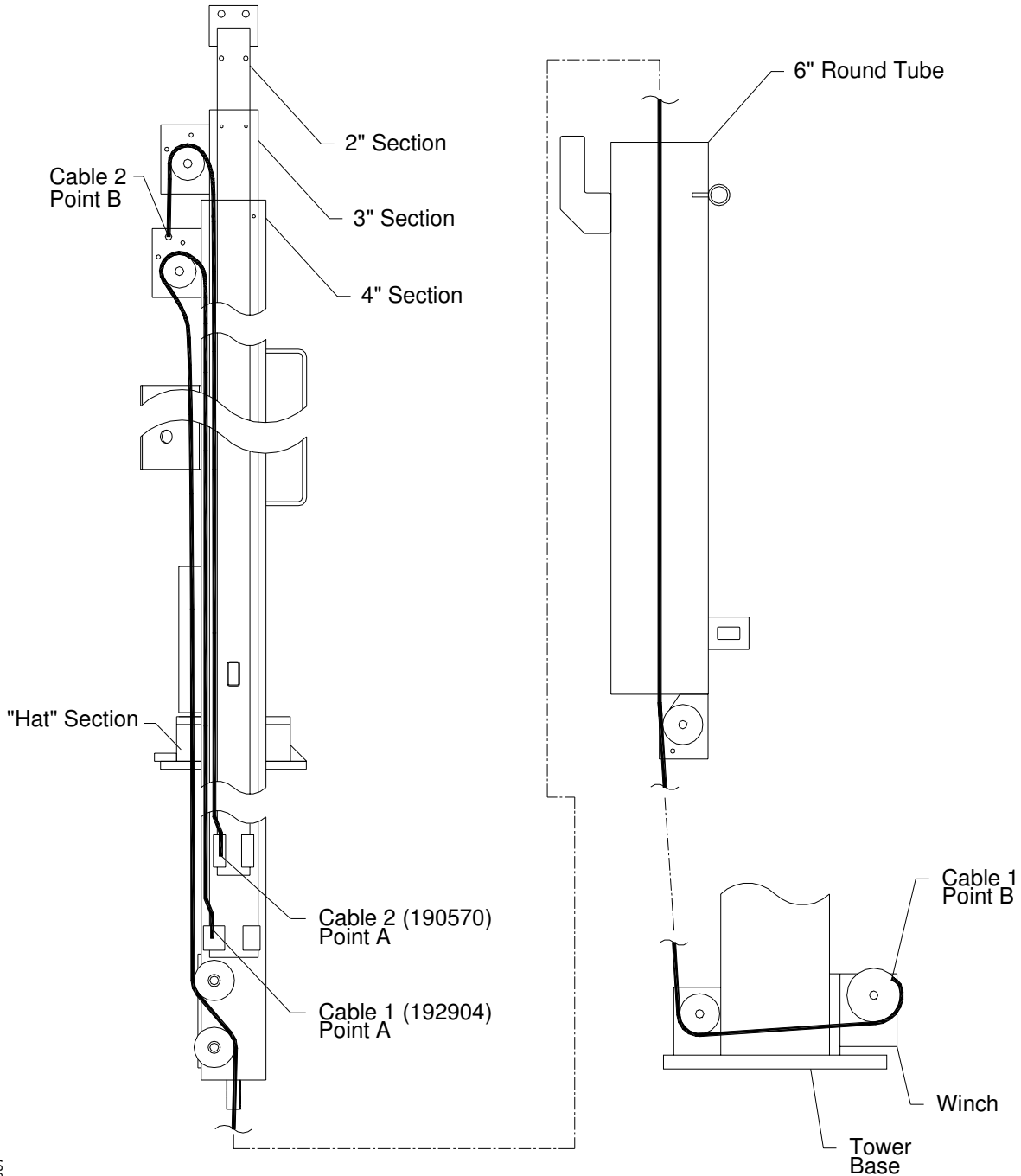

©Amida Industries, Inc. 1997

Created: 9-5-97

Revised: a) d)
b) e)
c) f)

By: Spectrum

Document:

PARTS MANUAL

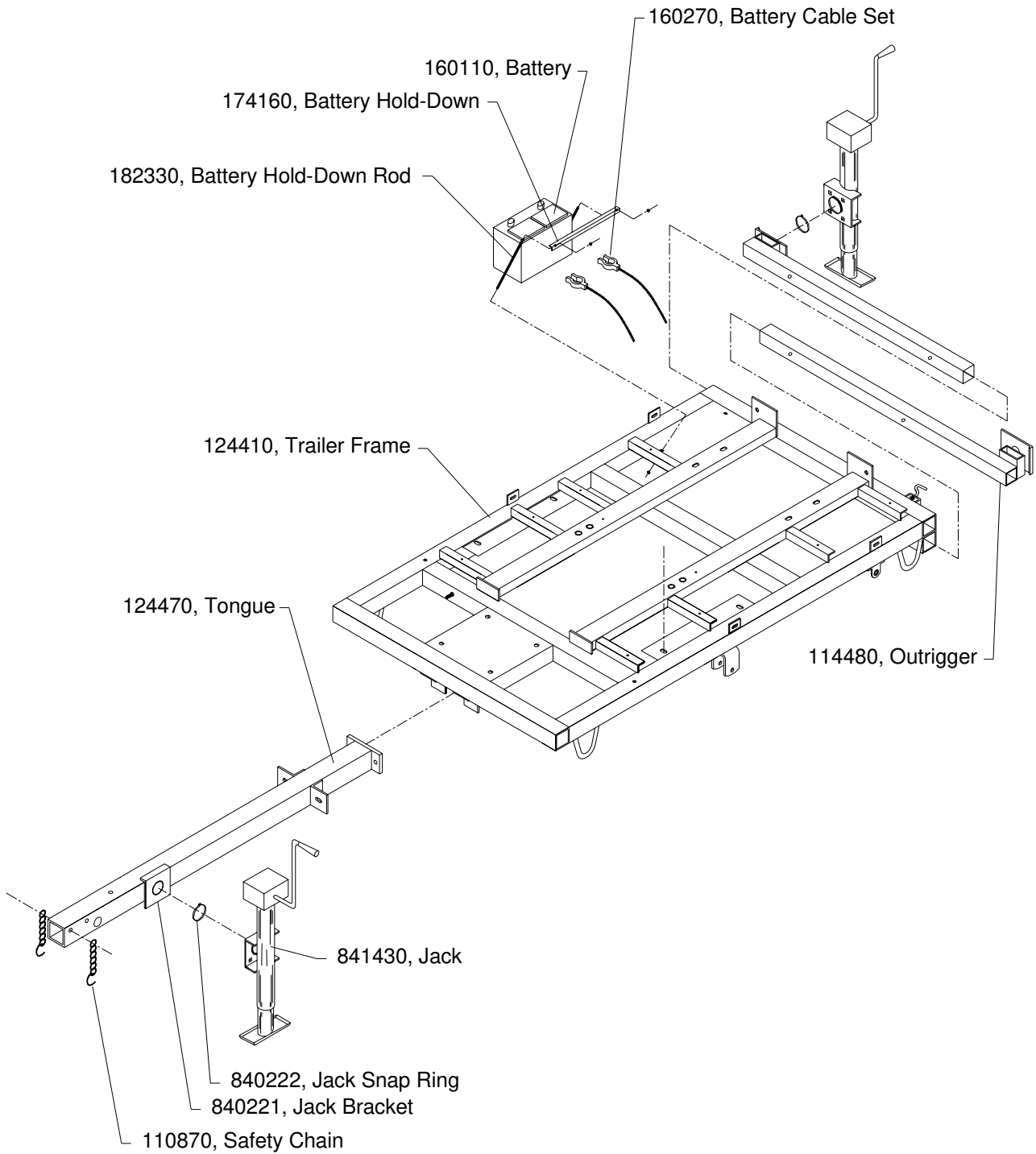

©Amida Industries, Inc. 1997

Created: 9-5-97

Revised: a) d)
b) e)
c) f)

Document:

By: Spectrum



Model:

AL4000 LIGHT TOWER

Page:

Title:

Fuel Tank

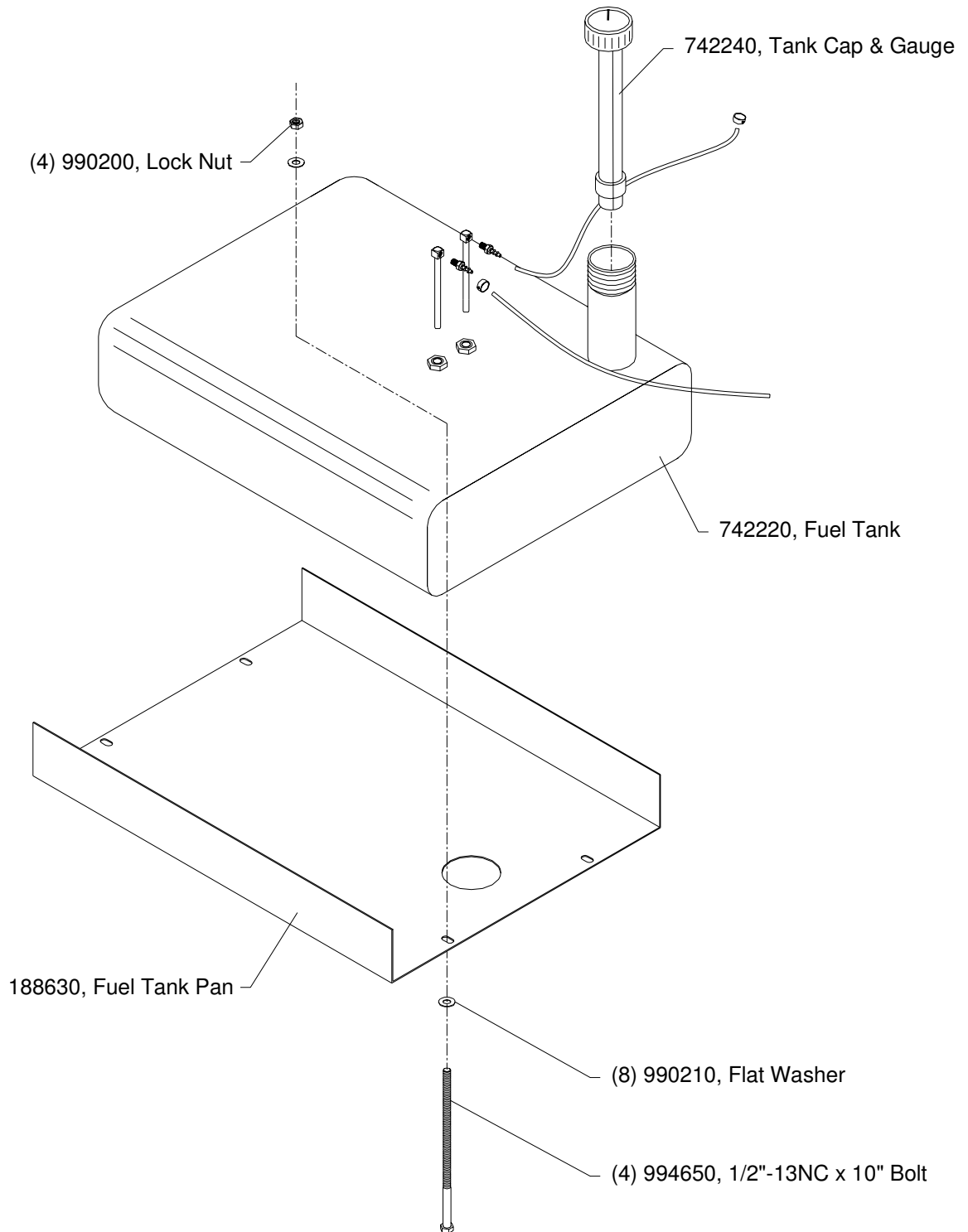

©Amida Industries, Inc. 1997

Created: 9-5-97

Revised: a) d)
b) e)
c) f)

Document:

By: Spectrum

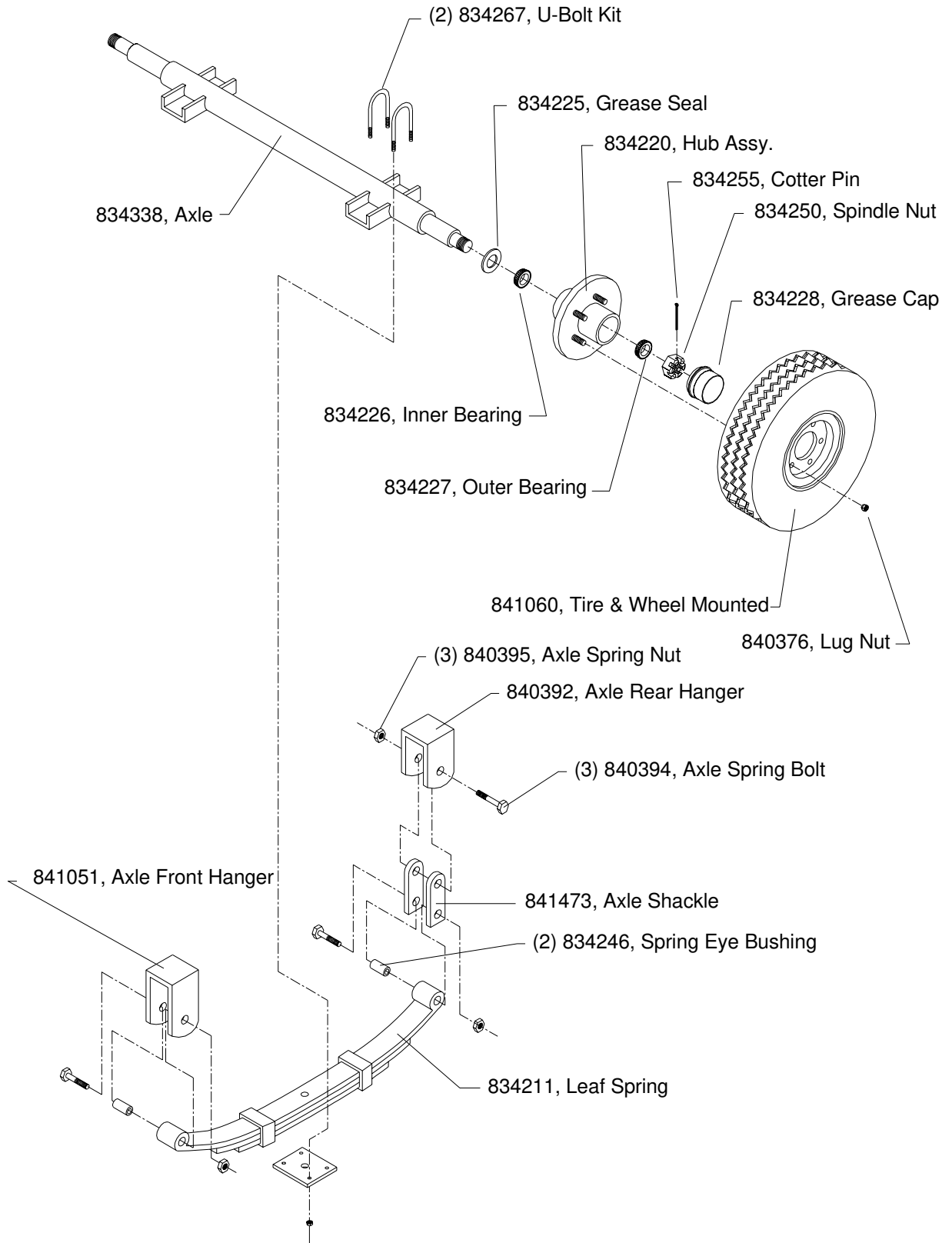

©Amida Industries, Inc. 1997

Created:	9-5-97	Revised:	a)	d)	Document:
By:	Spectrum		b)	e)	
			c)	f)	



Model:

AL4000 LIGHT TOWER

Page:

Title:

Cabinet Assy.

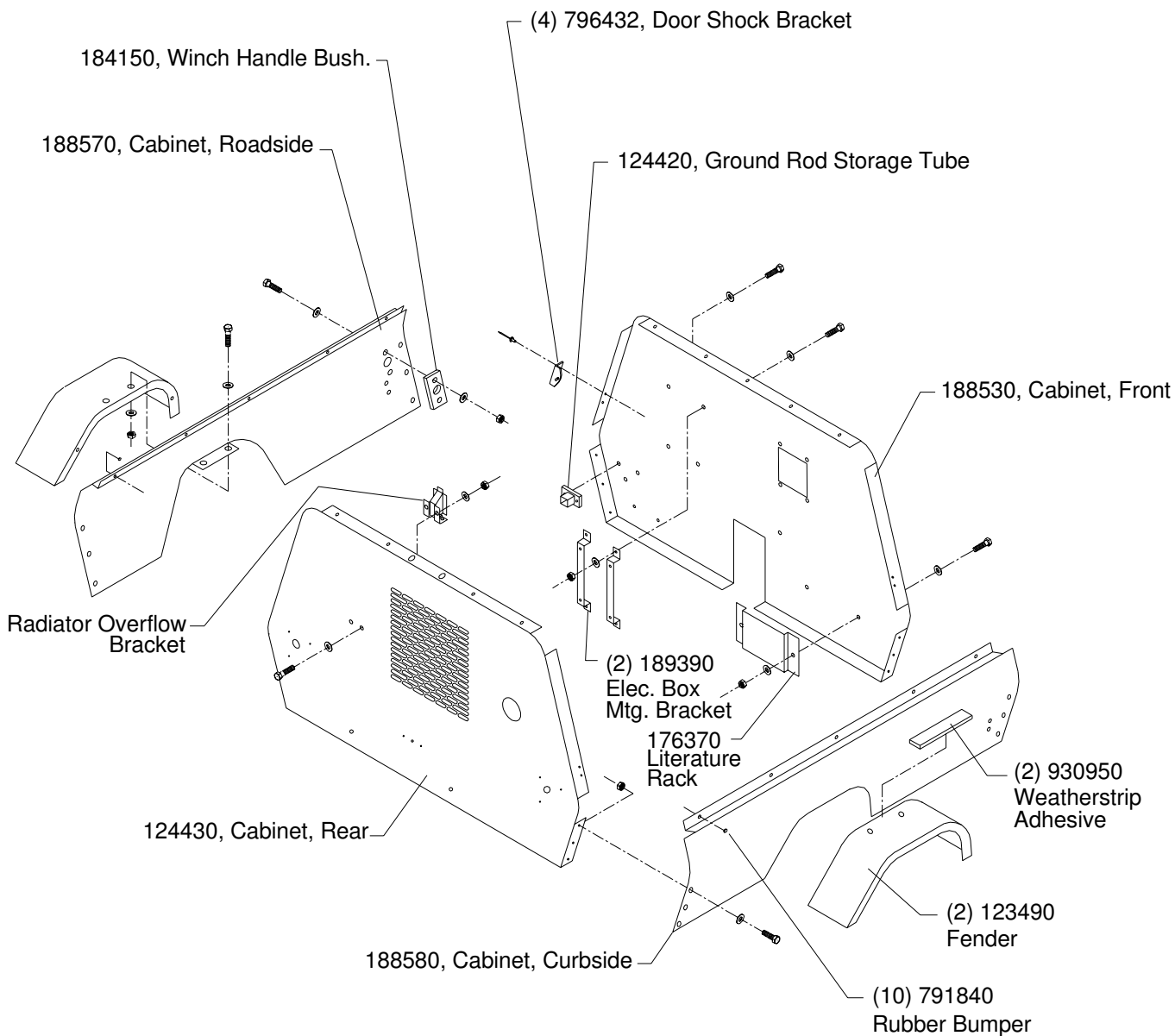

©Amida Industries, Inc. 1997

Created: 9-5-97

Revised:	a)	d)
	b)	e)
	c)	f)

Document:

By: Spectrum

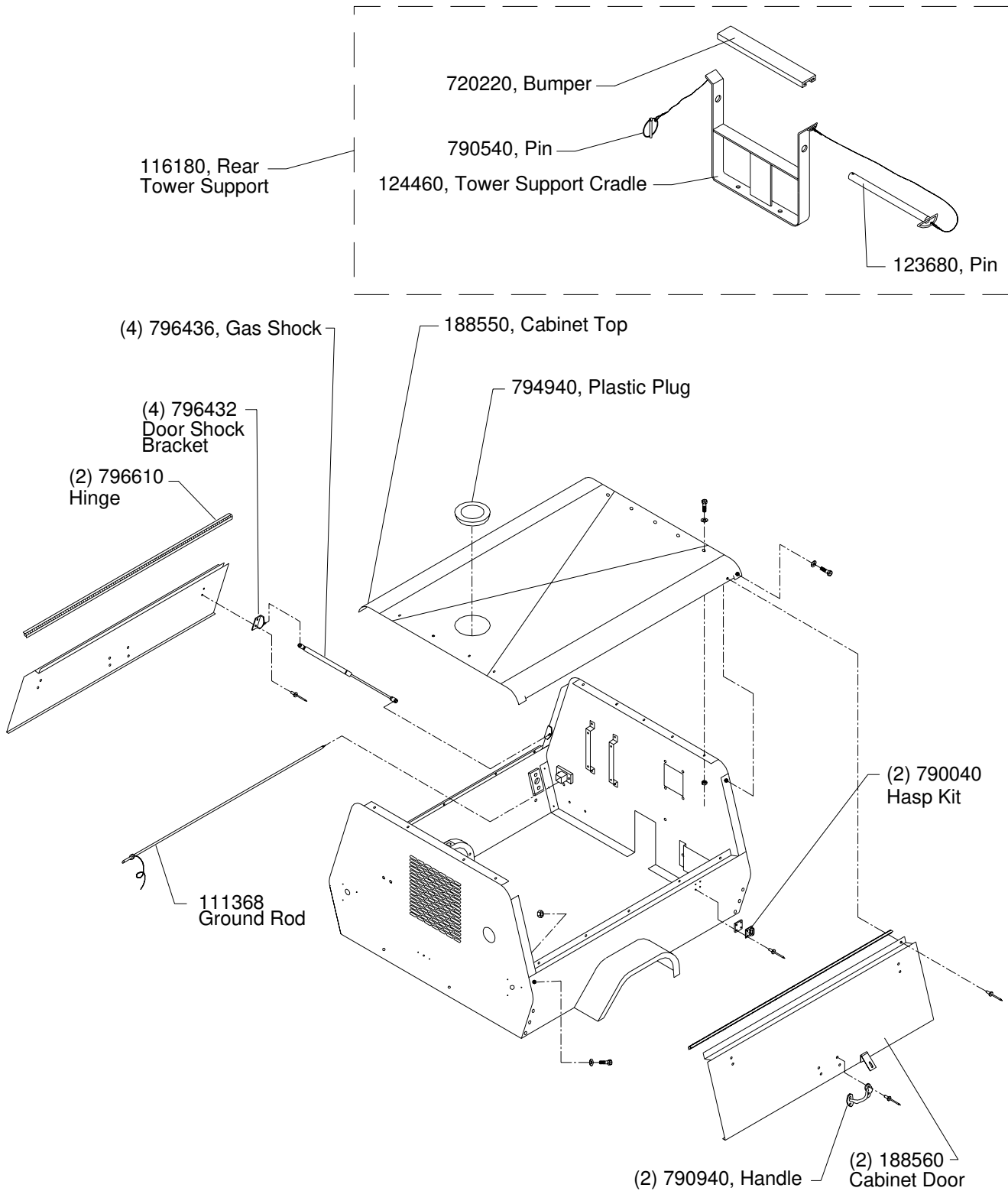

©Amida Industries, Inc. 1997

Created: 9-5-97

Revised: a) d)

Document:

By: Spectrum

b) e)



Model:

AL4000 LIGHT TOWER

Page:

Title:

Cab. Decal

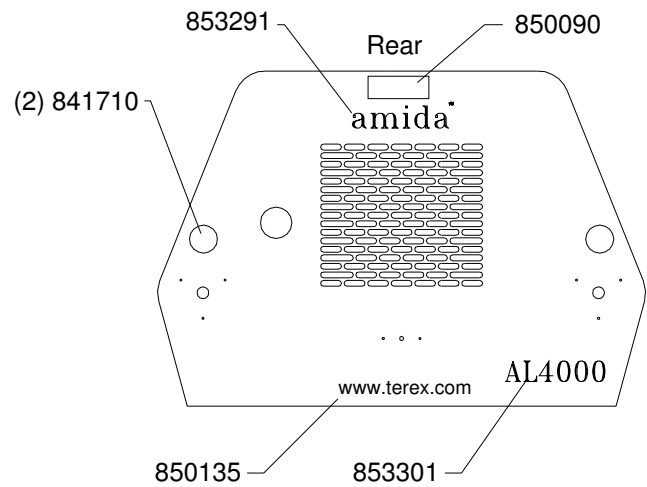
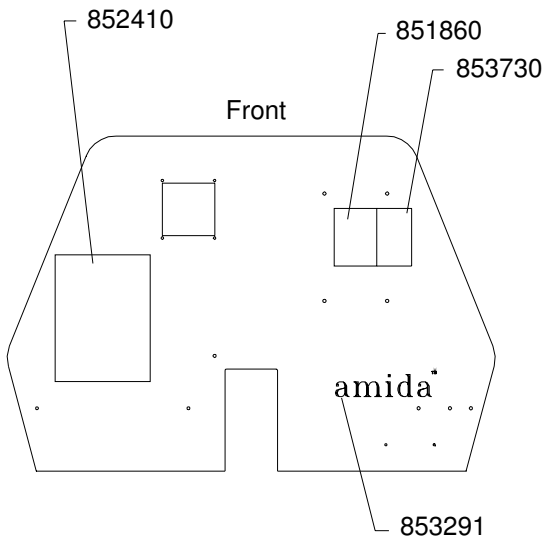
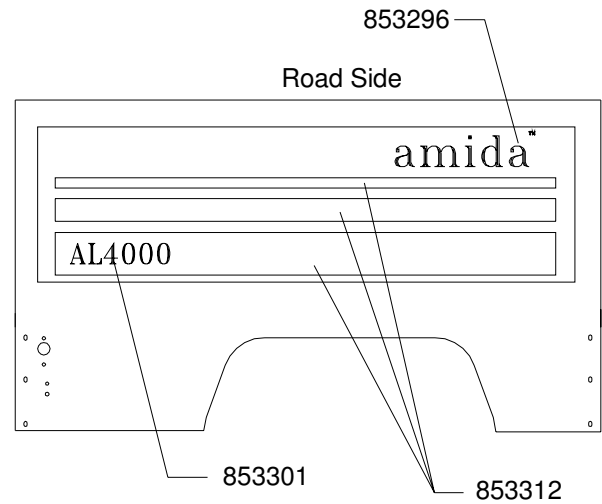
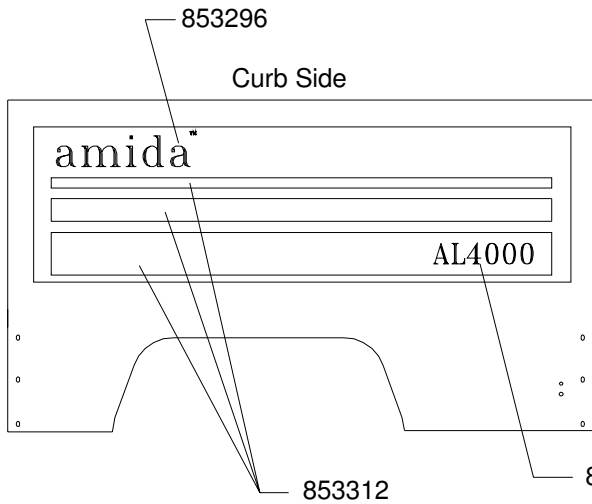
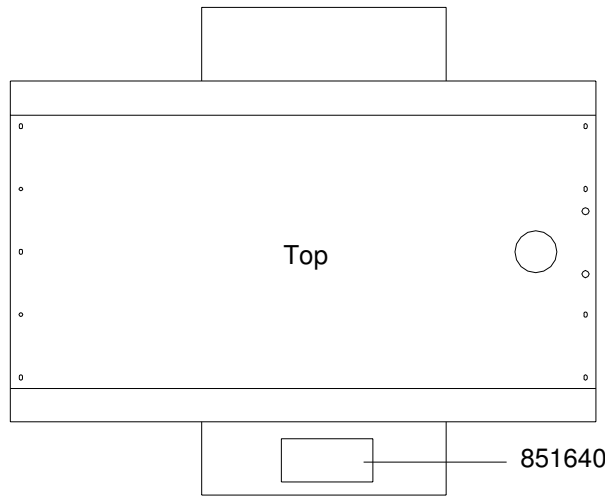

©Amida Industries, Inc. 1997

Created:

9-5-97

Revised:

- a)
- b)
- c)
- d)
- e)
- f)

22

Document:

By:

Spectrum



Model:

AL4000 LIGHT TOWER

Page:

Title:

Tower Assy.

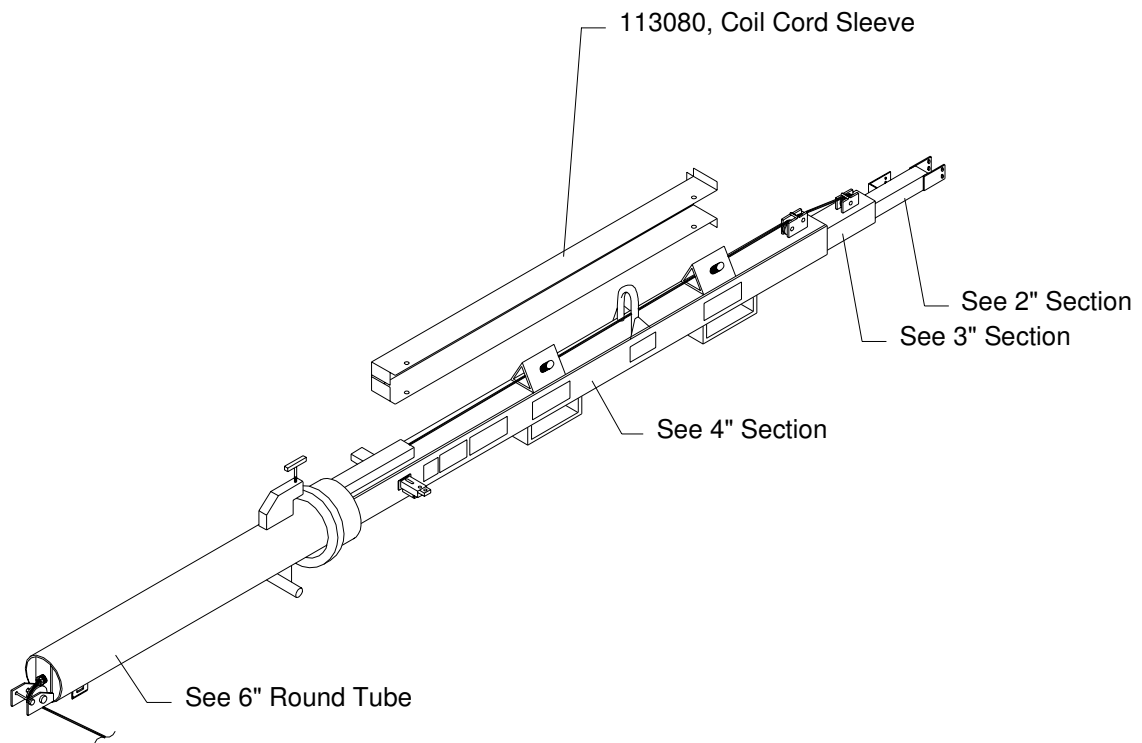

©Amida Industries, Inc. 1997

Created: 9-5-97

Revised: a) d)
b) e)
c) 23 f)

Document:

By: Spectrum

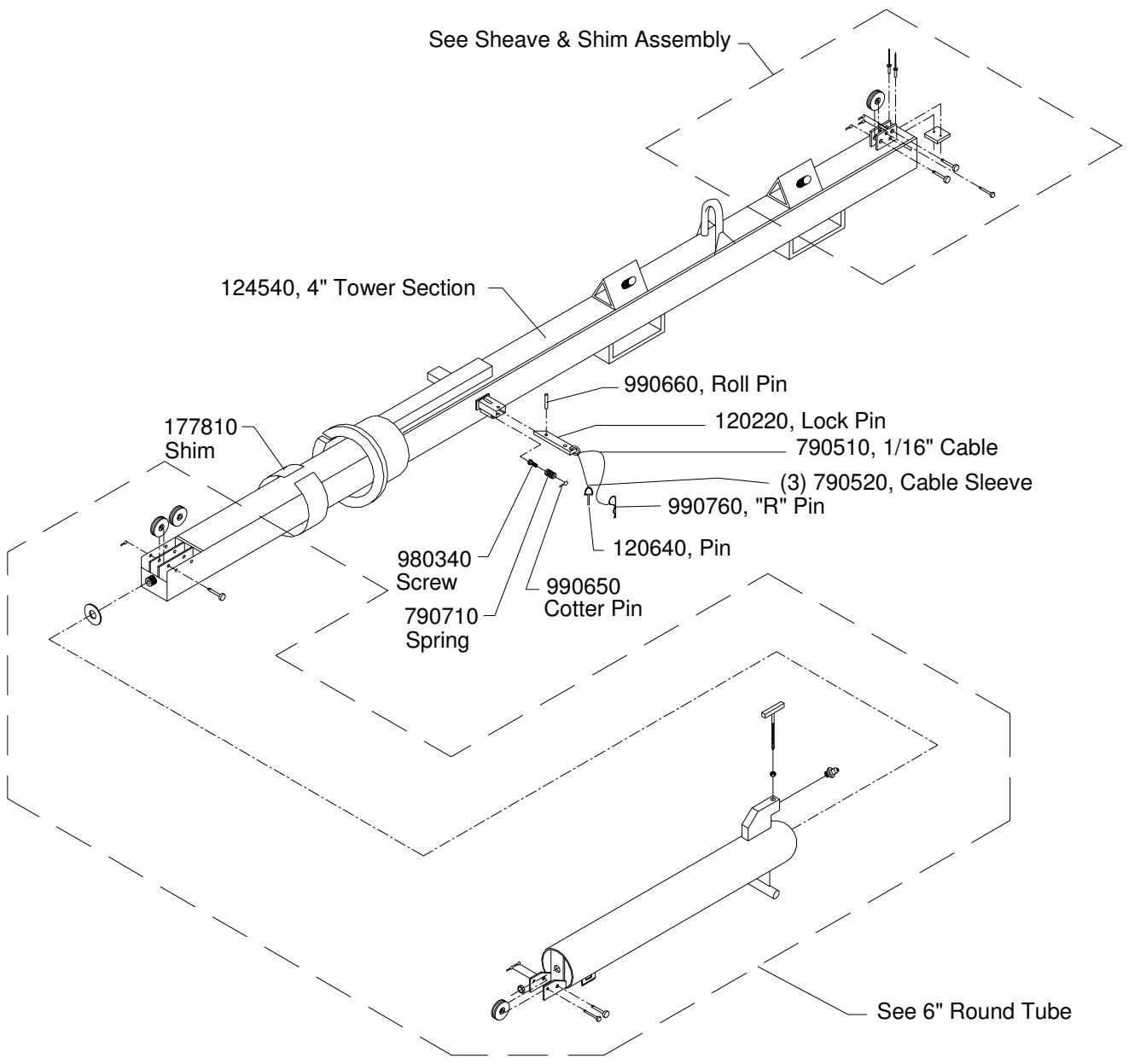

©Amida Industries, Inc. 1997

Created:	9-5-97	Revised:	a)	d)	Document:
By:	Spectrum		b)	e)	
			c)	f)	

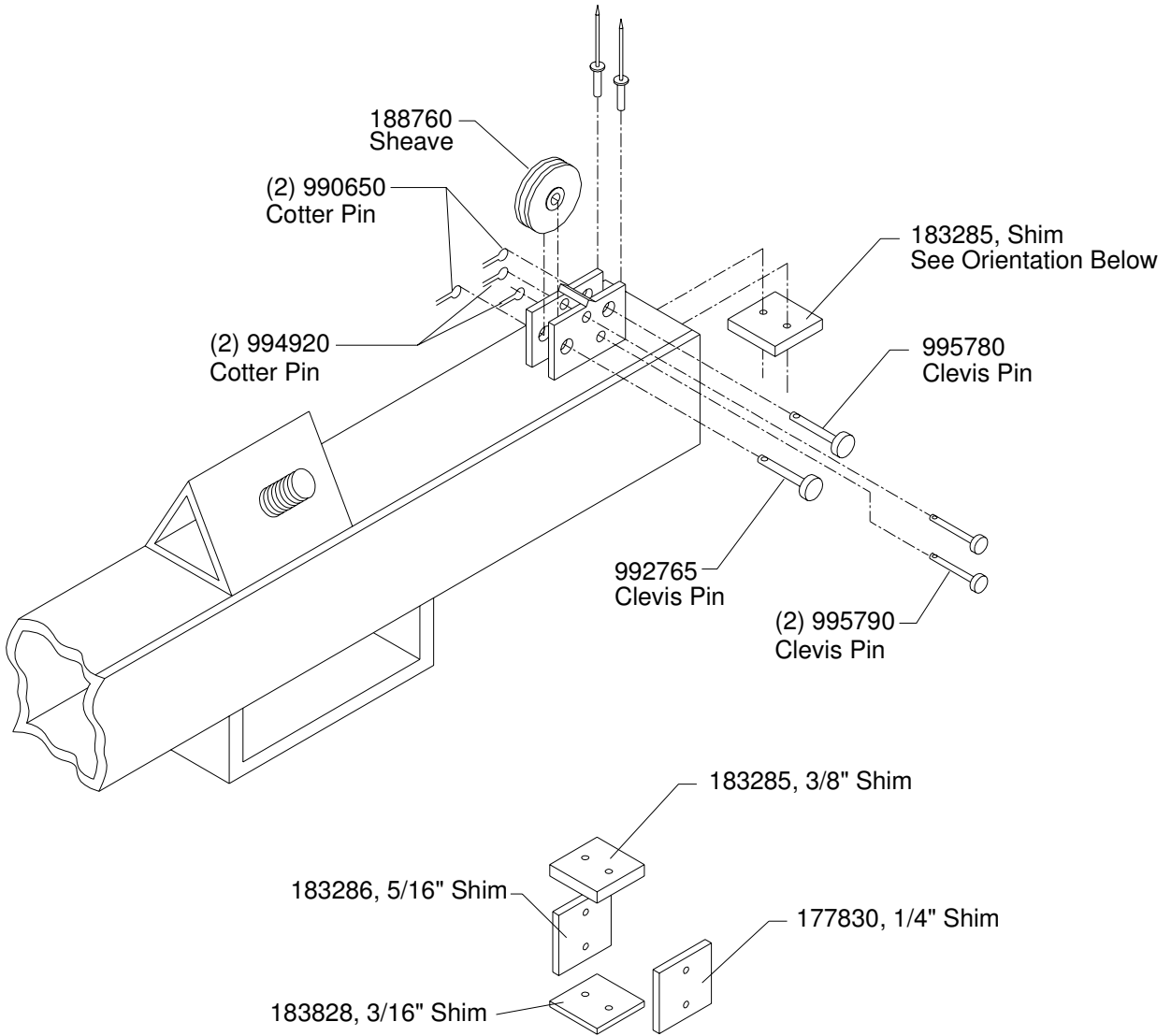

Orientation of Shims Inside Tube

©Amida Industries, Inc. 1997

Created:	9-5-97	Revised:	a)	d)	Document:
By:	Spectrum		b)	e)	
			c)	f)	
			25		

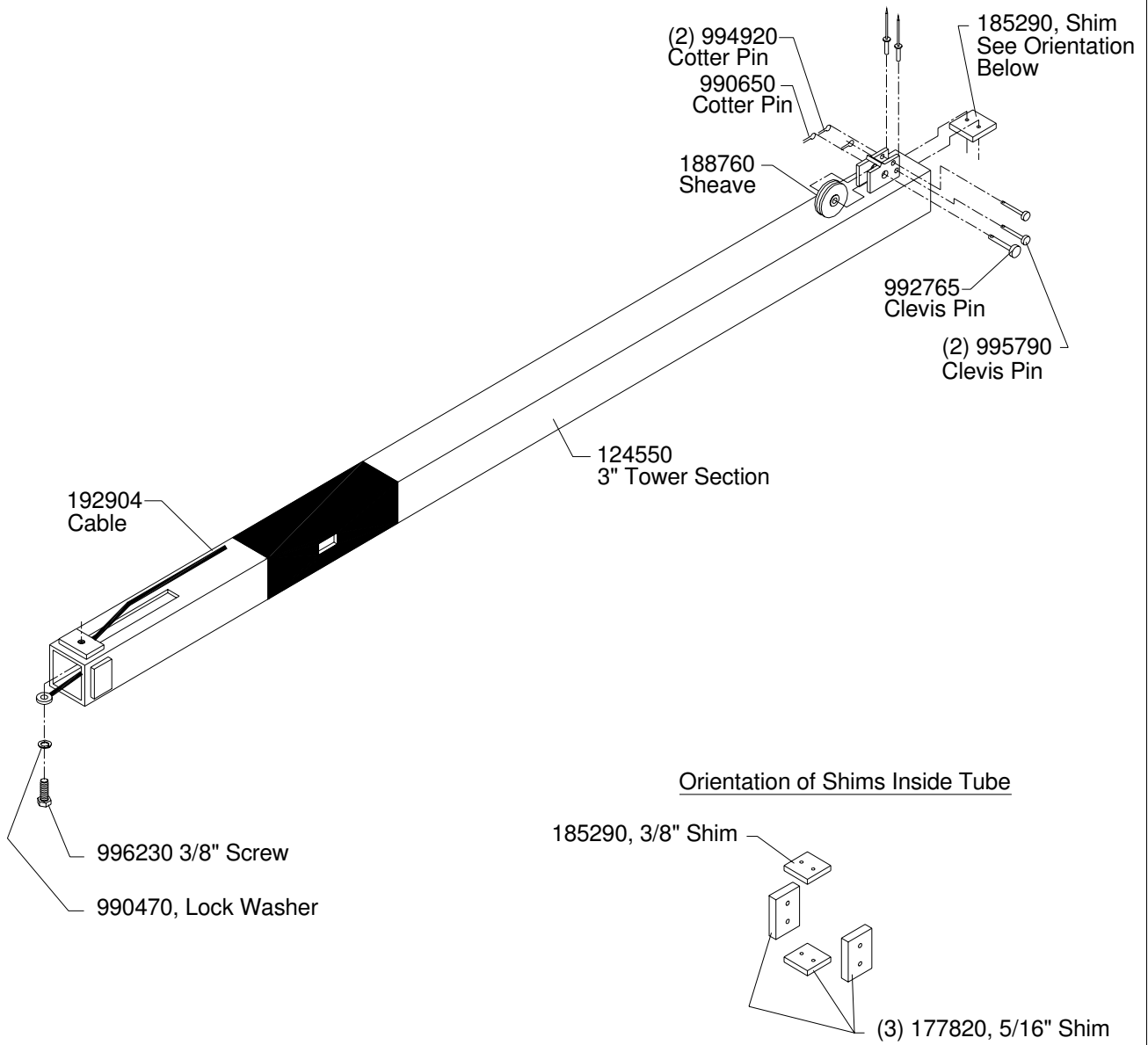

©Amida Industries, Inc. 1997

Created: 9-5-97	Revised: a) d) b) e) c) 26 f)	Document:
By: Spectrum		



Model:

AL4000 LIGHT TOWER

Page:

Title:

2" Section

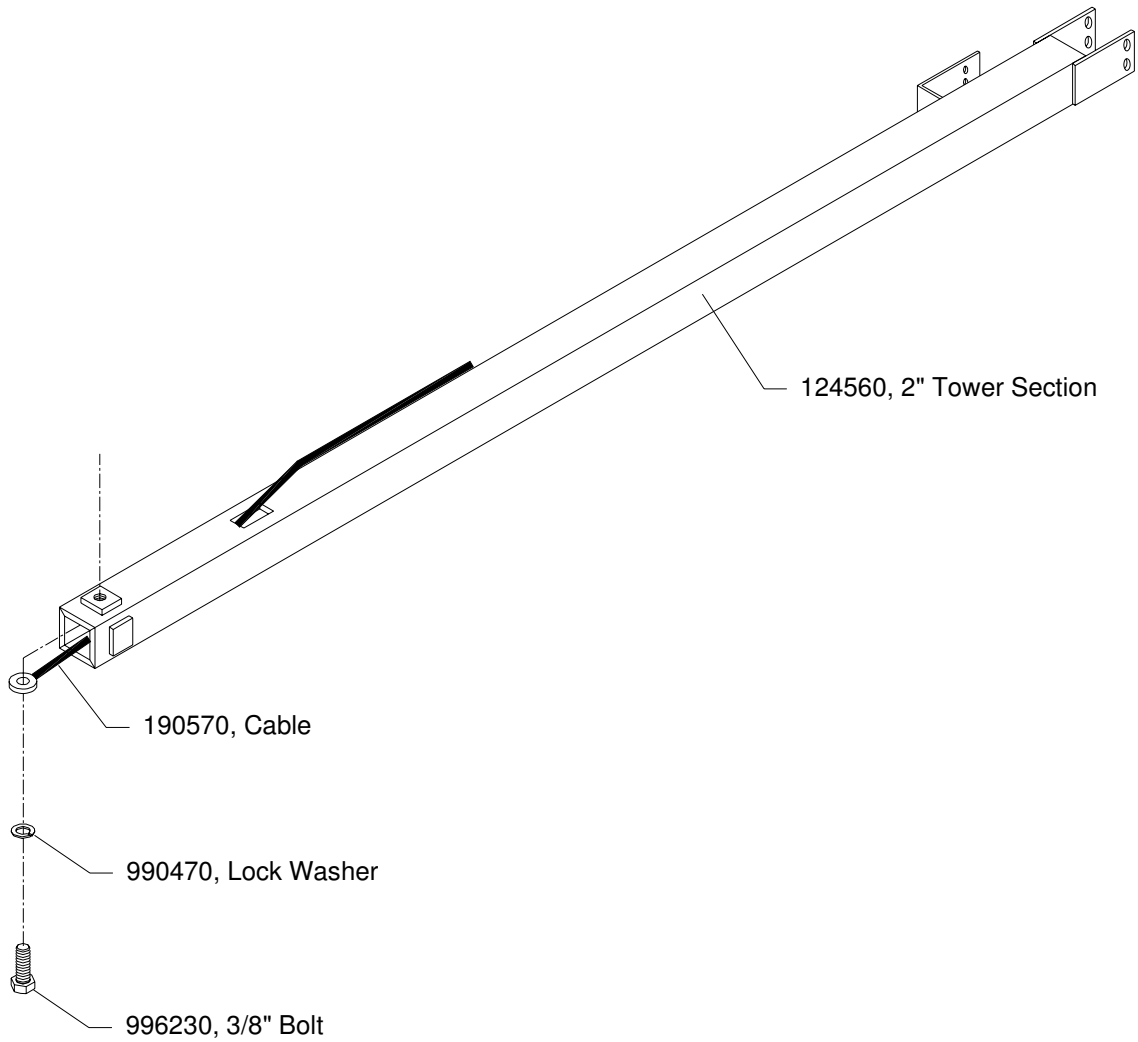

©Amida Industries, Inc. 1997

Created: 9-5-97

Revised: a) d)
b) e)
c) 27 f)

Document:

By: Spectrum

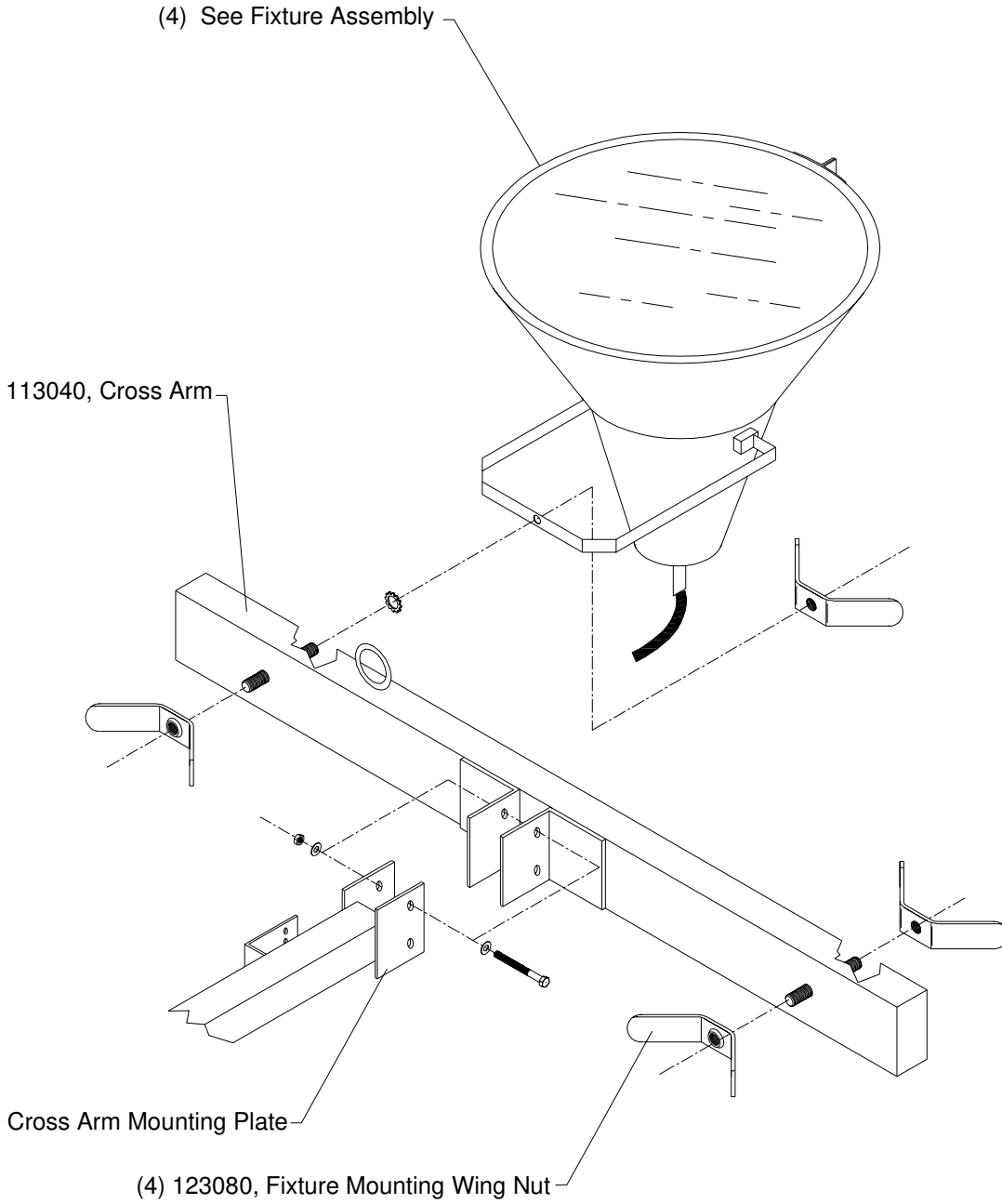

©Amida Industries, Inc. 1997

Created: 9-5-97

Revised: a) d)
b) e)
c) 28 f)

Document:

By: Spectrum

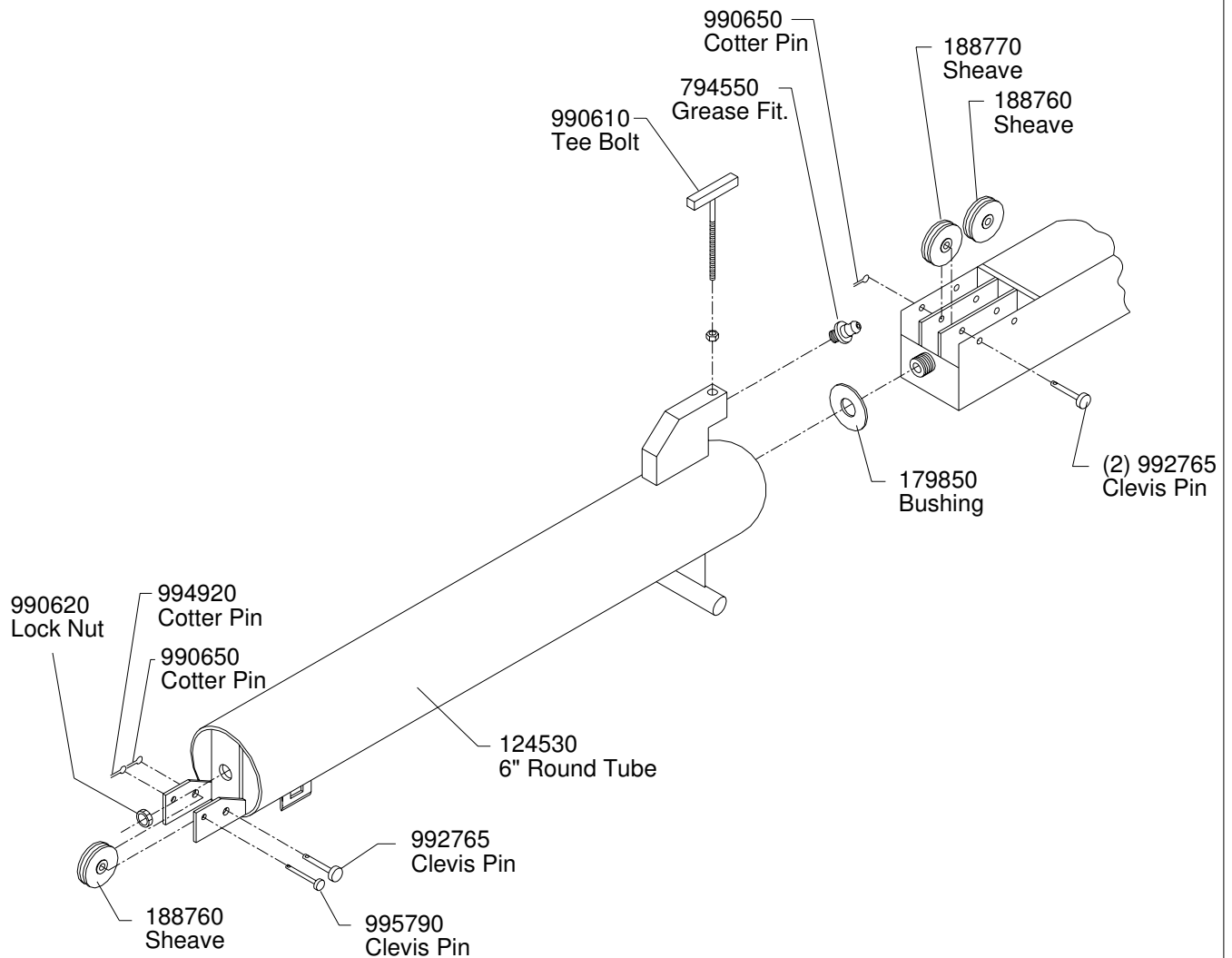

©Amida Industries, Inc. 1997

Created: 9-5-97

Revised: a) d)
b) e)
c) 29 f)

Document:

By: Spectrum



Model: AL4000 LIGHT TOWER
Title: Tower w/ Base Assy.

Page:

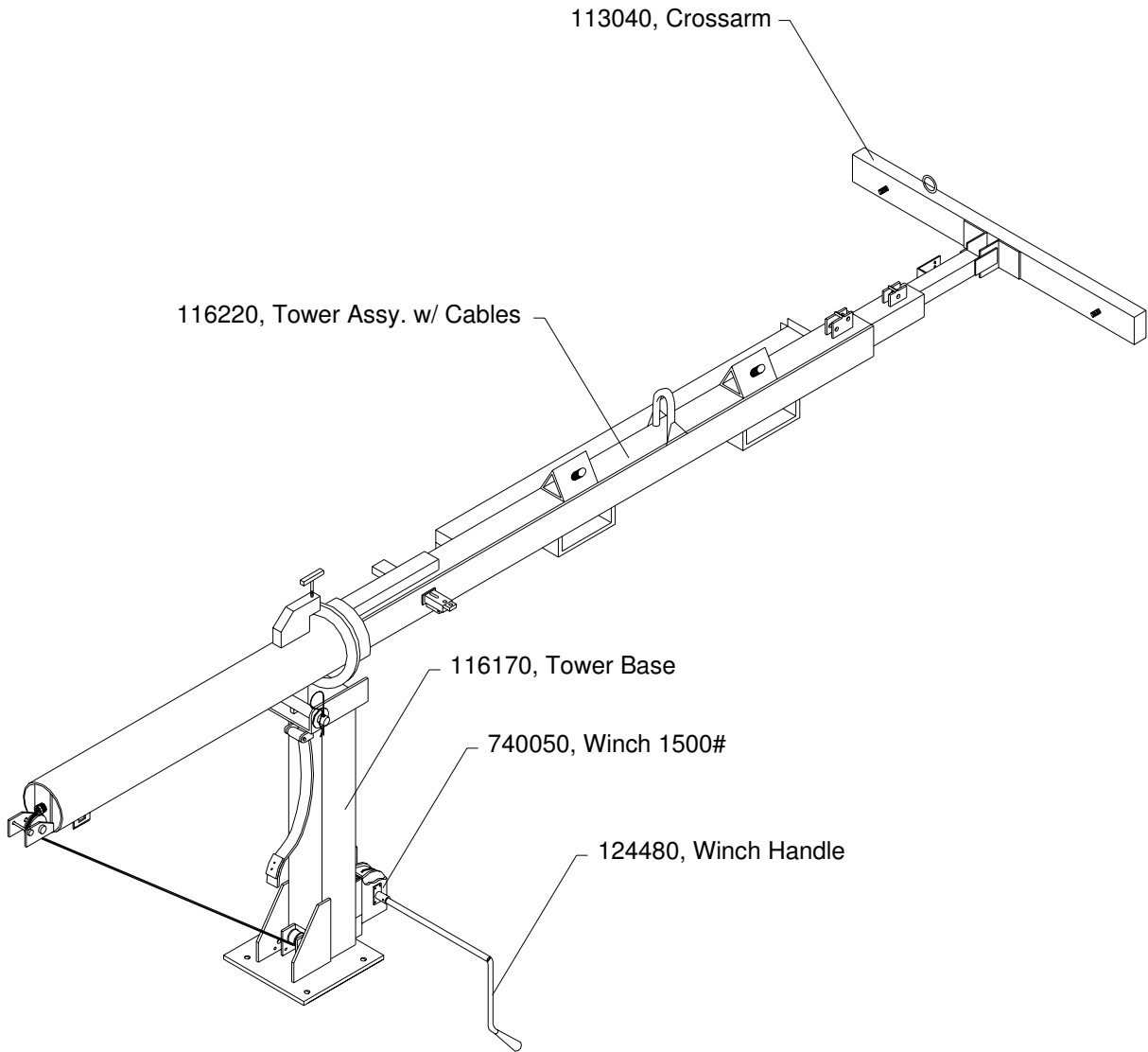

©Amida Industries, Inc. 1997

Created: 9-5-97
By: Spectrum

Revised: a) d)
b) e)
c) 30 f)

Document:



Model:

AL4000 LIGHT TOWER

Page:

Title:

Tower Base Assy.

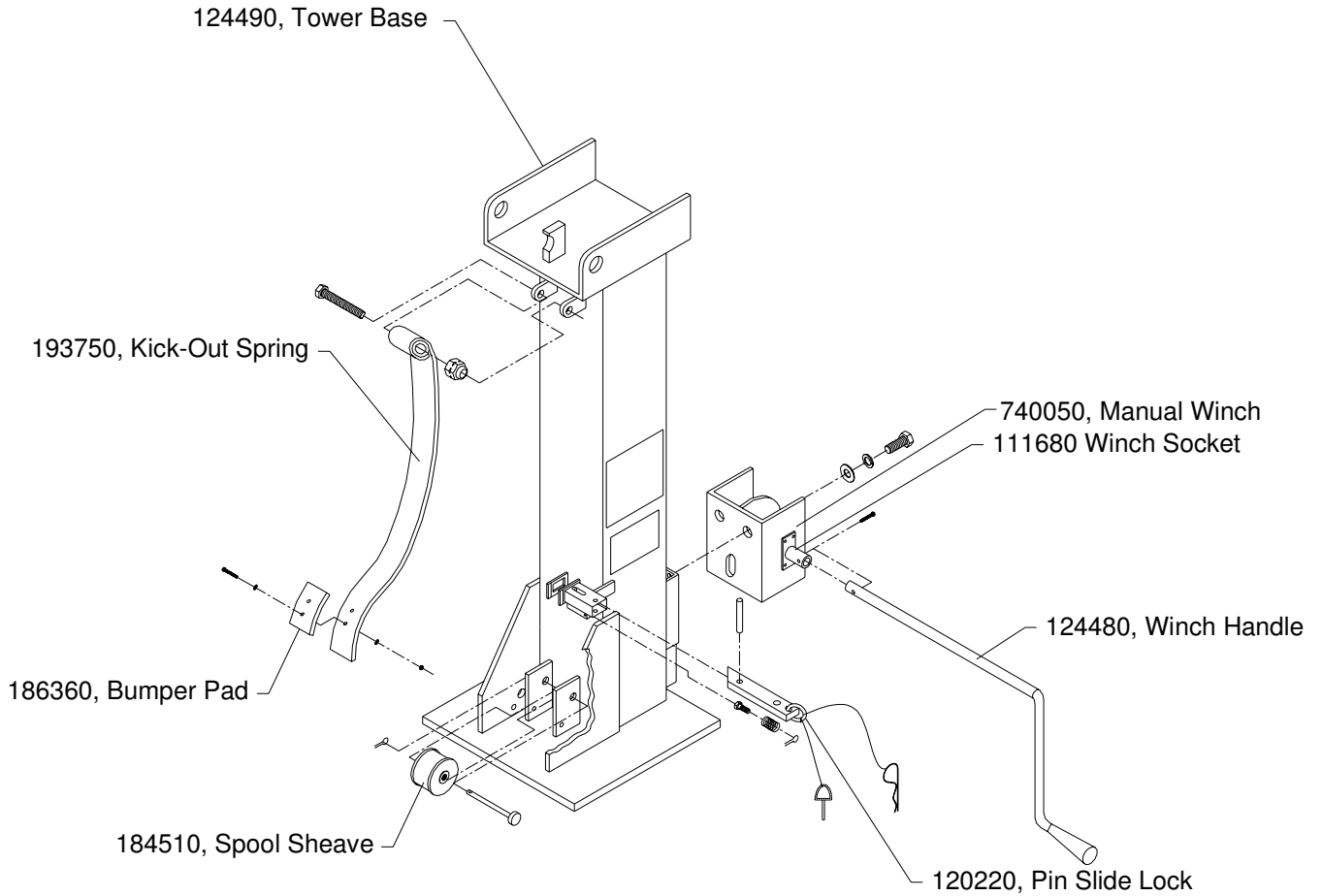

©Amida Industries, Inc. 1997

Created: 9-5-97

Revised: a) d)
b) e)
c) f)

Document:

By: Spectrum

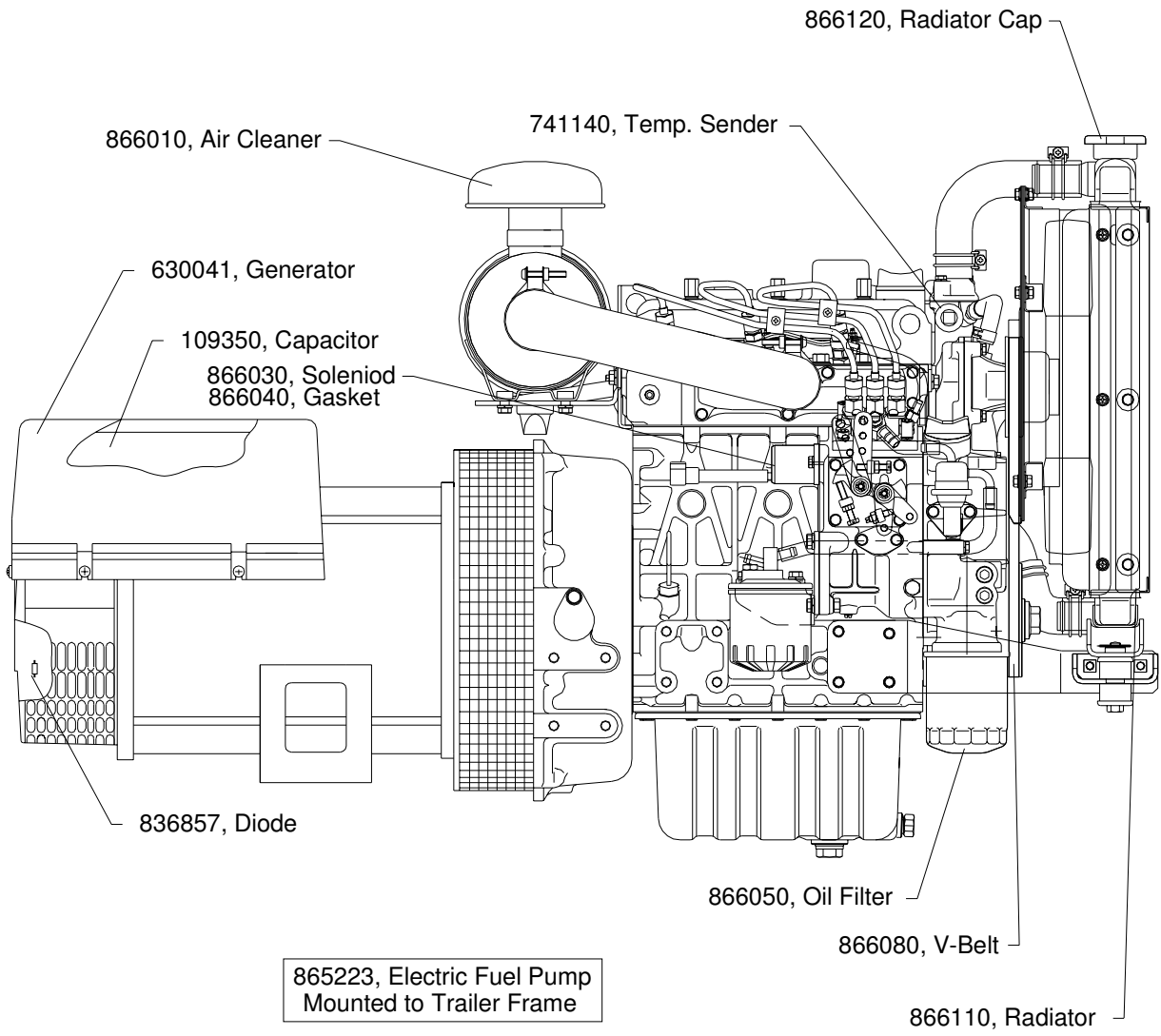

©Amida Industries, Inc. 1997

Created: 9-5-97
 By: Spectrum

Revised: a) d)
 b) e)
 c) 32 f)

Document:



Model:

AL4000 LIGHT TOWER

Page:

Title:

Genset, Kub-D905/L-S 6KW

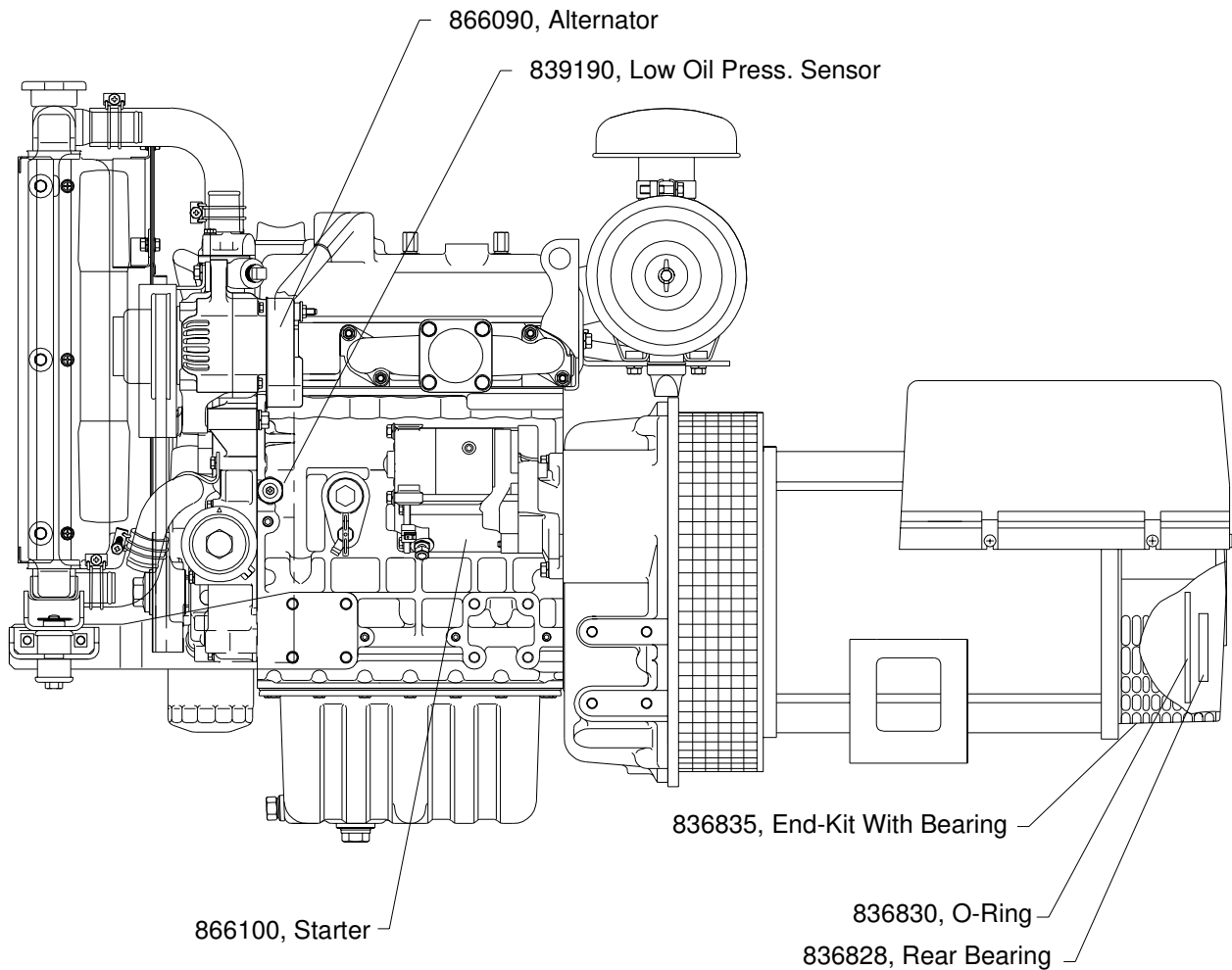

©Amida Industries, Inc. 1997

Created: 9-5-97

Revised: a) d)
b) e)
c) 33 f)

Document:

By: Spectrum

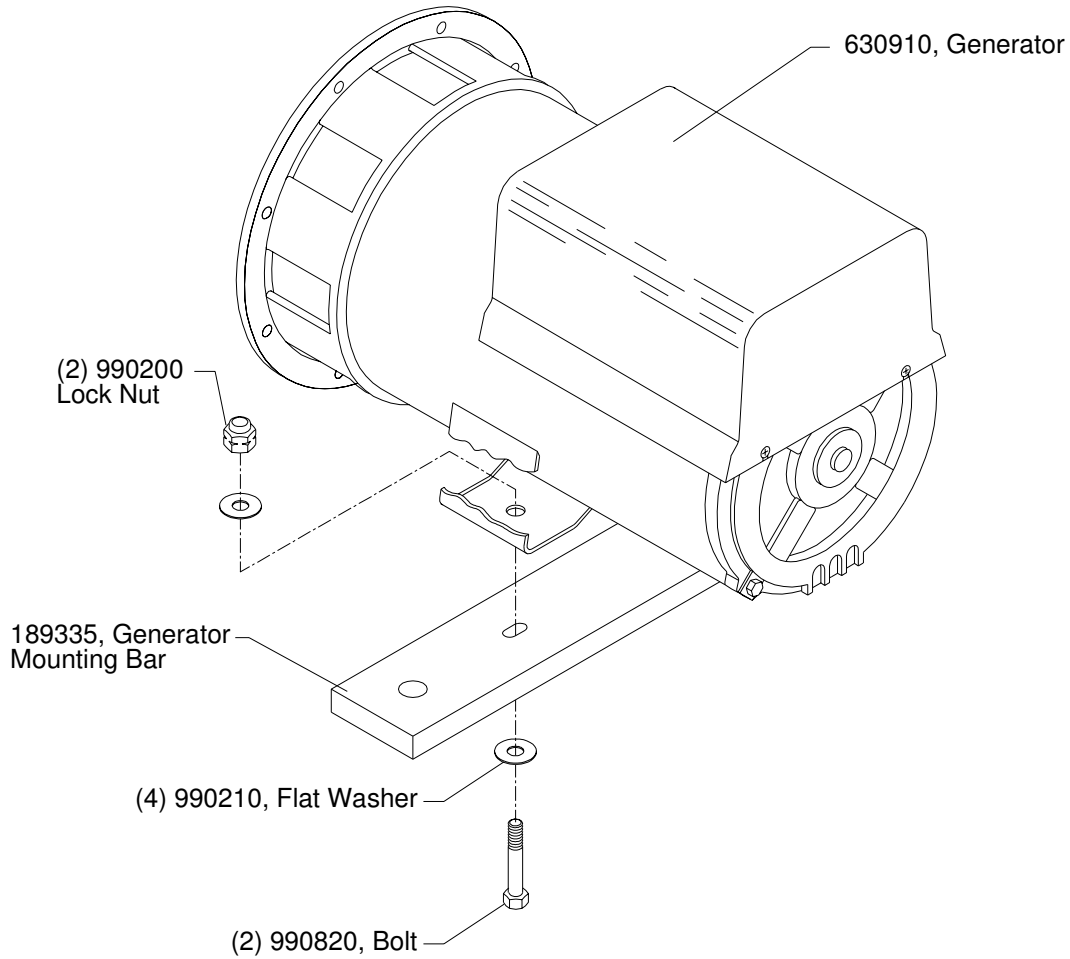
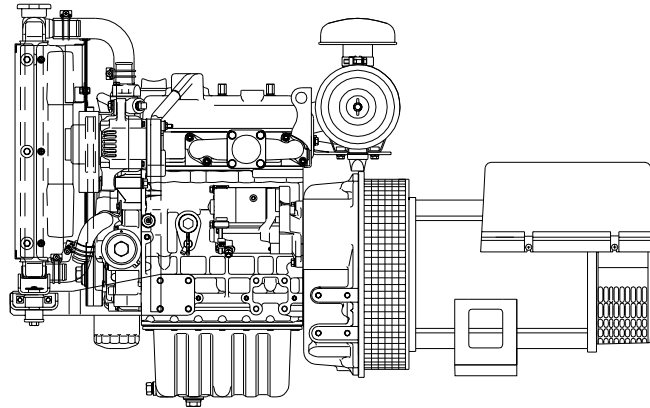

©Amida Industries, Inc. 1997

Created: 9-5-97

Revised: a) d)
b) e)
c) 34 f)

Document:

By: Spectrum



Model:

AL4000 LIGHT TOWER

Page:

Title:

Right Side Radiator/Engine Mtg. Bracket

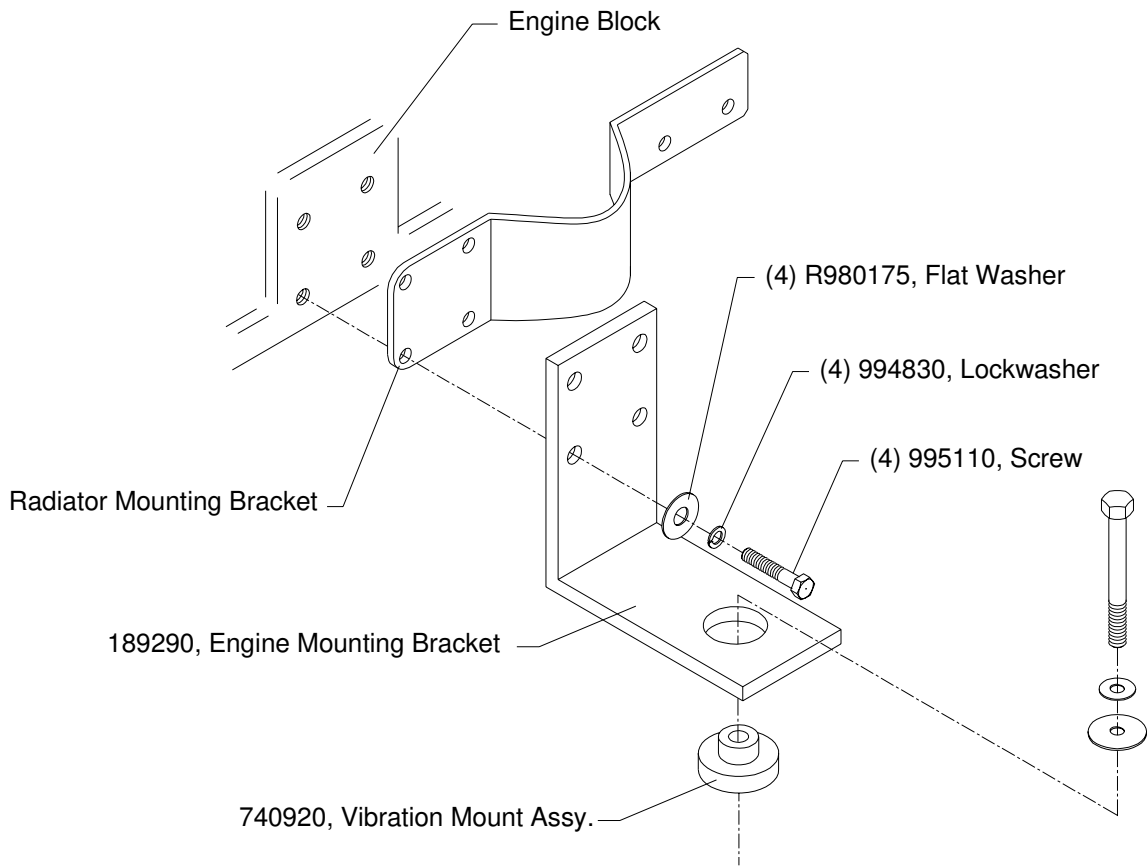
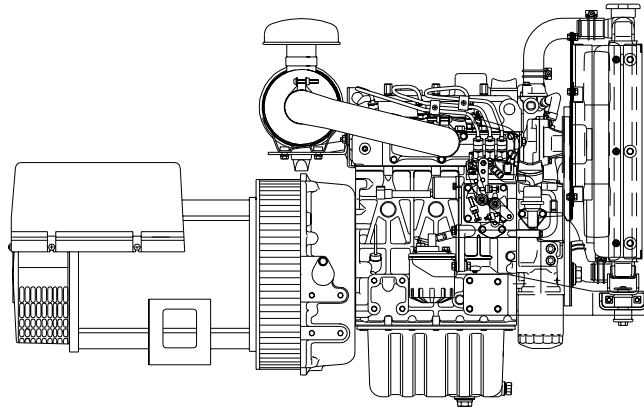

©Amida Industries, Inc. 1997

Created: 9-5-97

Revised: a) d)
 b) e)
 c) f)

Document:

By: Spectrum

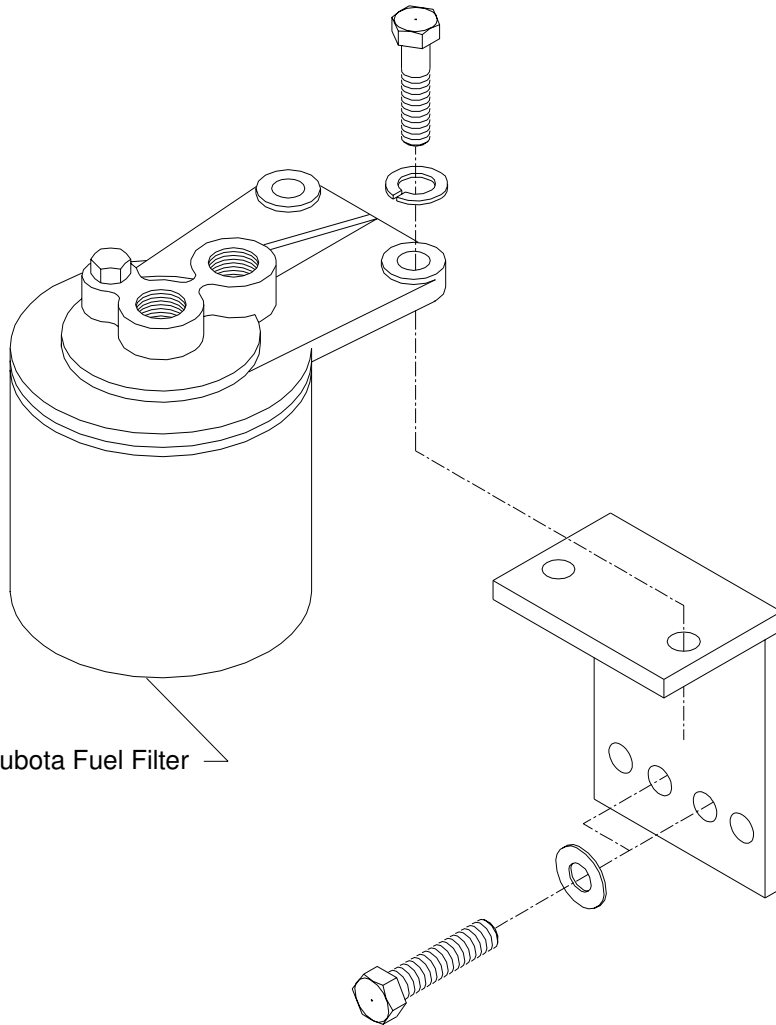
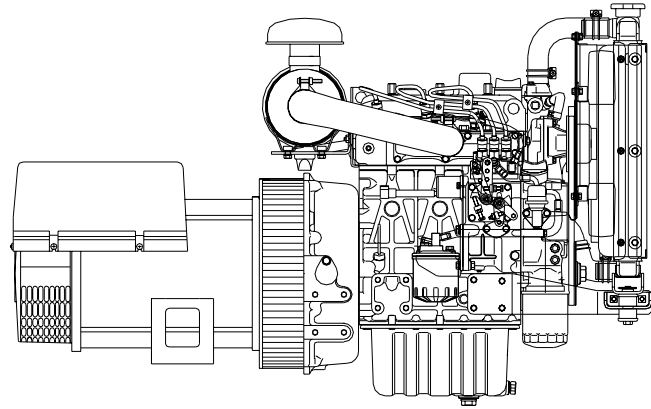

866080, Kubota Fuel Filter

©Amida Industries, Inc. 1997

Created: 9-5-97

Revised: a) d)
b) e)
c) 36 f)

Document:

By: Spectrum

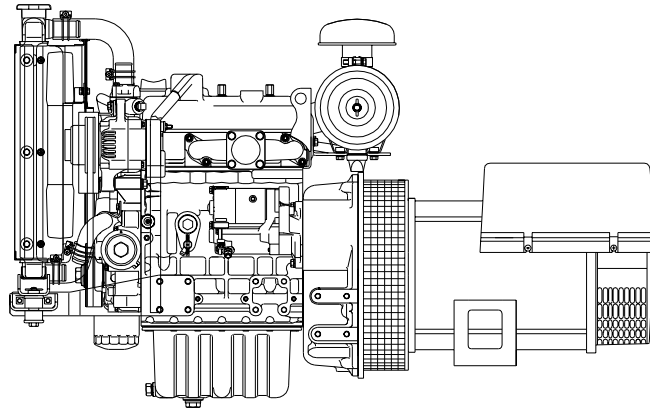

866120, Radiator Cap

975014, Overflow Tank

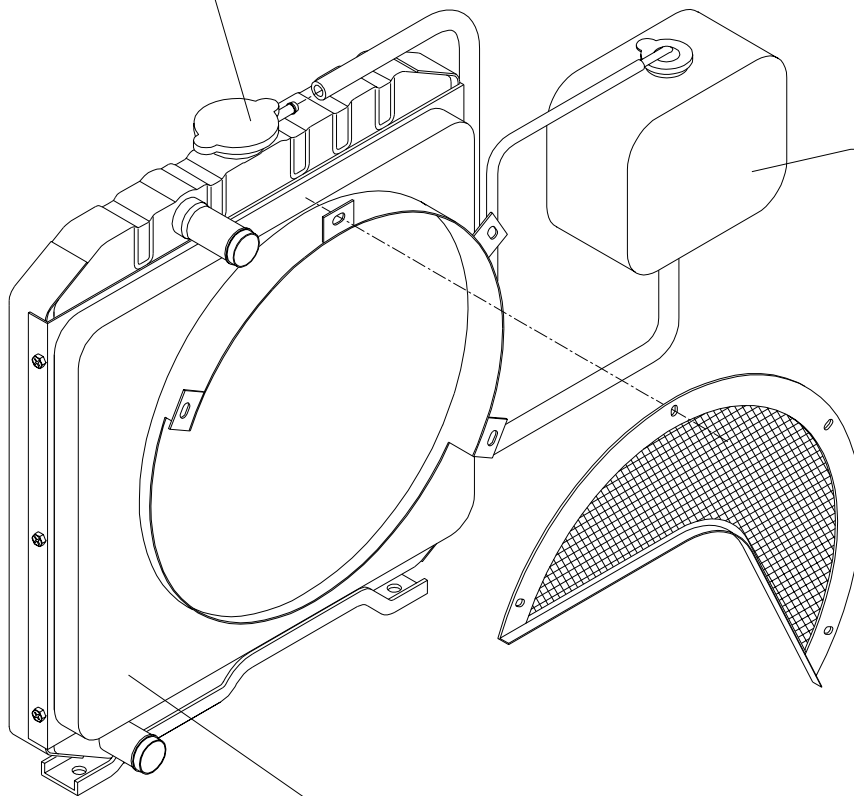

866110, Radiator

©Amida Industries, Inc. 1997

Created: 9-5-97
By: Spectrum

Revised: a) d)
b) e)
c) 37 f)

Document:

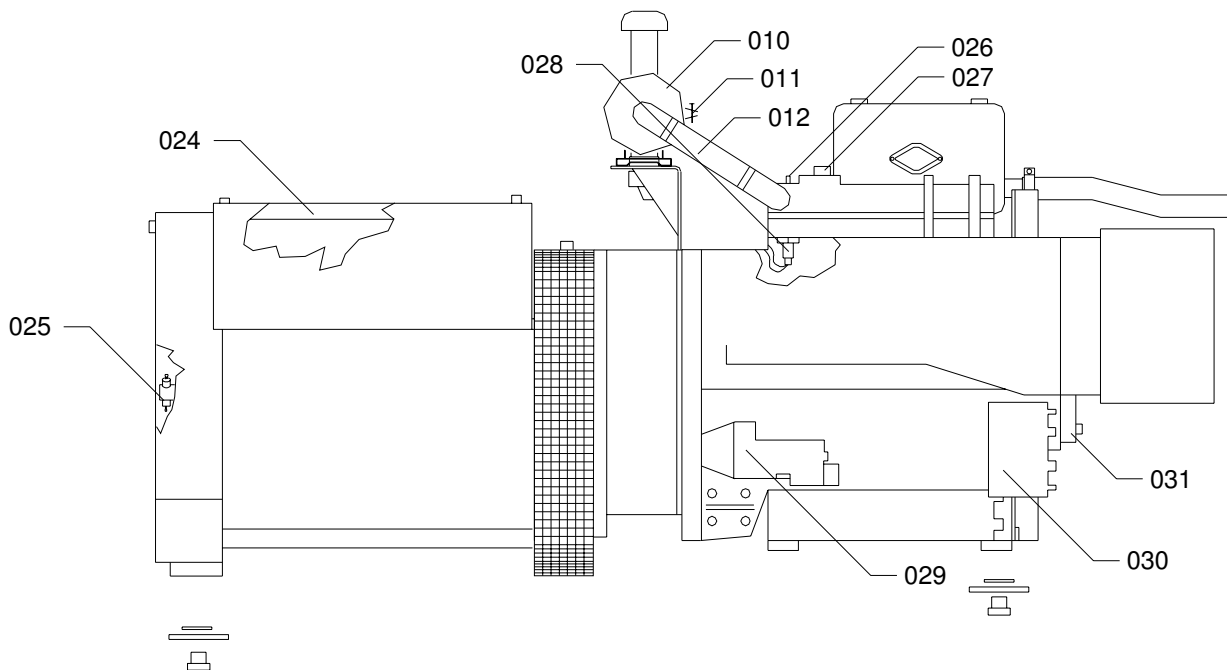
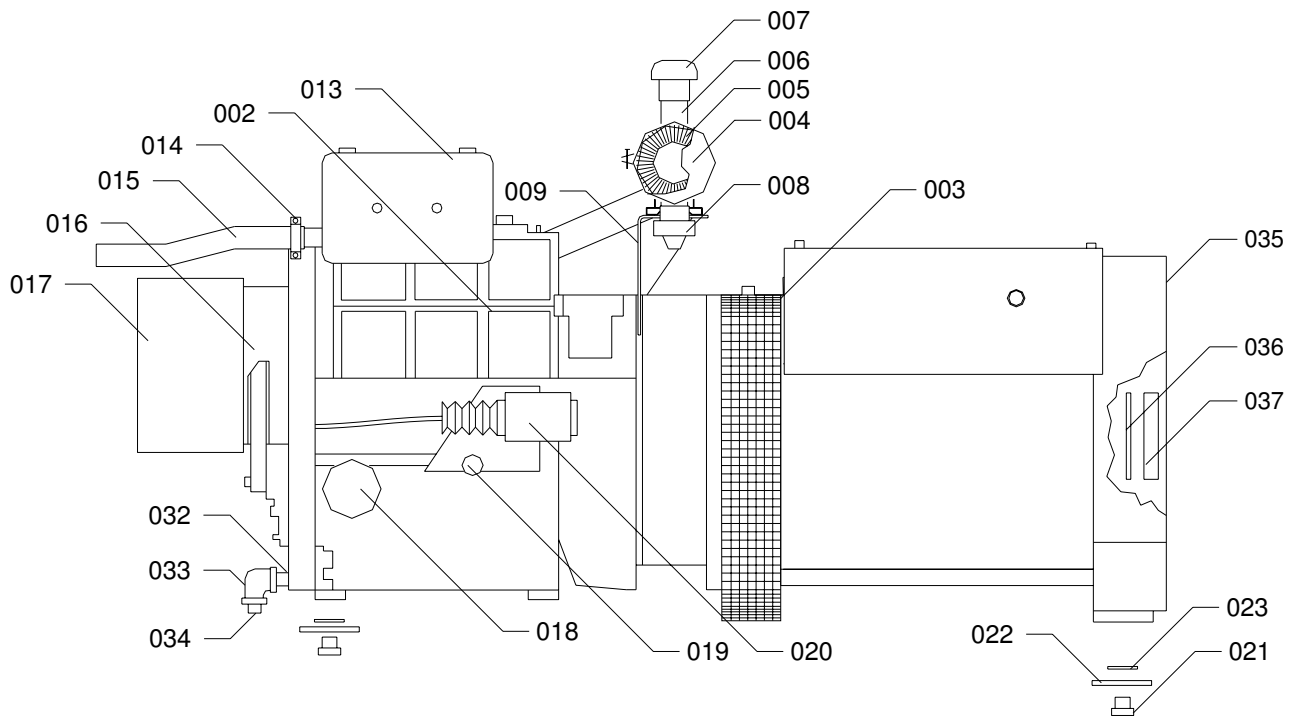

001_____GENSET ASSEMBLY COMPLETE

GENSET, ALPHA LPA3/L-S, AL4000

PARTS IDENTIFICATION DRAWING

DRWN BY	WW	DATE	2/8/96	DWG NO	9609
---------	----	------	--------	--------	------

DRAWING# 9609 - GENSET, ALPHA-LPA3 /L-S 6KW-AL4000

ITEM *	PART #	DESCRIPTION	U/M
-001	116360	MA-GENSET-ALPHA LPA3/L-S 6KW/7.5KW/AL4000	EA
-002	732130	ENGINE,LISTER ALPHA LPA3,BUILD 8,12.1HP	EA
-003	630950	GENERATOR, L-S,8KW,38M7 N/A:USE PARTI# 630950	EA
-004	740400	AIR CLEANER BODY W/EL FWG05-2512 , PAINT-001BK	EA
-005	834450	DONALDSON P18-2050 AIR CLEANER ELEMENT	EA
-006	740443	TUBE,AIR CLEANER.DON HOOD EXT. 2X4.5	EA
-007	740430	AIR CLEANER HOOD GAX00-2018 , PAINT-4628G	EA
-008	834465	DONALDSON P10- 3198 A/C VACUATOR VALVE	EA
-009	124220	AS-AIR CLEANER BRACKET ALPHA/L-S ,3602, AL4000	EA
-010	740420	AIR CLEANER ELBOWS P10-5529 & 90HL2	EA
-011	740410	AIR CLEANER BANDS P00-2348 , PAINT-0018K	EA
-012	791580	CLAMP,HOSE #32 1-9/16 TO 2-1/2 S/S	EA
-013	742200	MUFFLER, LISTER ALPHA LPA3	EA
-014	795050	CLAMP,MUFFLER 1-3/4"ZP	EA
-015	188450	FP-MUFFLER TAILPIPE ALPHA-LPA3, 4357 ,AL4000	EA
-016	831998	LISTER 750-10190 AIR INLET DUCT ADAPTOR	EA
-017	187500	FP-AIR TUBE 8.25ID X6L XI" THK SPONGE	EA
-018	831993	LISTER 751-10620 OIL FILTER	EA
-019	631995	LISTER 750-10231 LOP SWITCH KIT	EA
-020	832750	SOLENOID LISTER 3-WIRE SYNCHRO START 1502ES	EA
-021	740920	VIBRATION MOUNT,3OOLB C8A20-300-11	EA
-022	185100	FP-GENERATOR MOUNT BAR L-S/LIMA, 2466, 4C/AL4	EA
-023	990410	WASHER ,FLAT, FENDER 2"ODX1-7/32"IDX16GA ZP	EA

DRAWING# 9609 - GENSET, ALPHA-LPA3 /L-S 6KW-AL4000

ITEM *	PART #	DESCRIPTION	U/M
-024	109350	KIT:CAPACITOR REPLACE FOR 6KW LEROY,70UF	EA
-025	836857	DIODE L5A38 MODEL 70HF90	EA
-026	831999	LISTER 751-40620 GLOW PLUG	EA
-027	832000	LISTER 750-40310 GLOW PLUG RELAY	EA
-028	831996	LISTER 570-32390 (ALPHA)HI-TEMP. SWITCH	EA
-029	831997	LISTER 750-13710 STARTER (ALPHA-LPA3)	EA
-030	831991	LISTER 750-11740 ALTERNATOR (ALPHA-LPA3)	EA
-031	831992	LISTER 751-17820 FAN BELT (ALPHA-LPA3)	EA
-032	896340	PIPE NIPPLE 3/8X2 GALV	EA
-033	891600	PIPE ELBOW 90 DEG 3/8" GALV.	EA
-034	894340	PIPE PLUG 3/S GALV	EA
-035	836835	LEROY SOMER 9AMBHLSA3S NDE END KIT W/O BRGING	EA
-036	836830	LEROY SOMER 0-RING ZL-LSA3S-257 RUBBER	EA
-037	836828	LEROY SOMER 9ASR6306ZZ REAR BRG LSA 38	EA

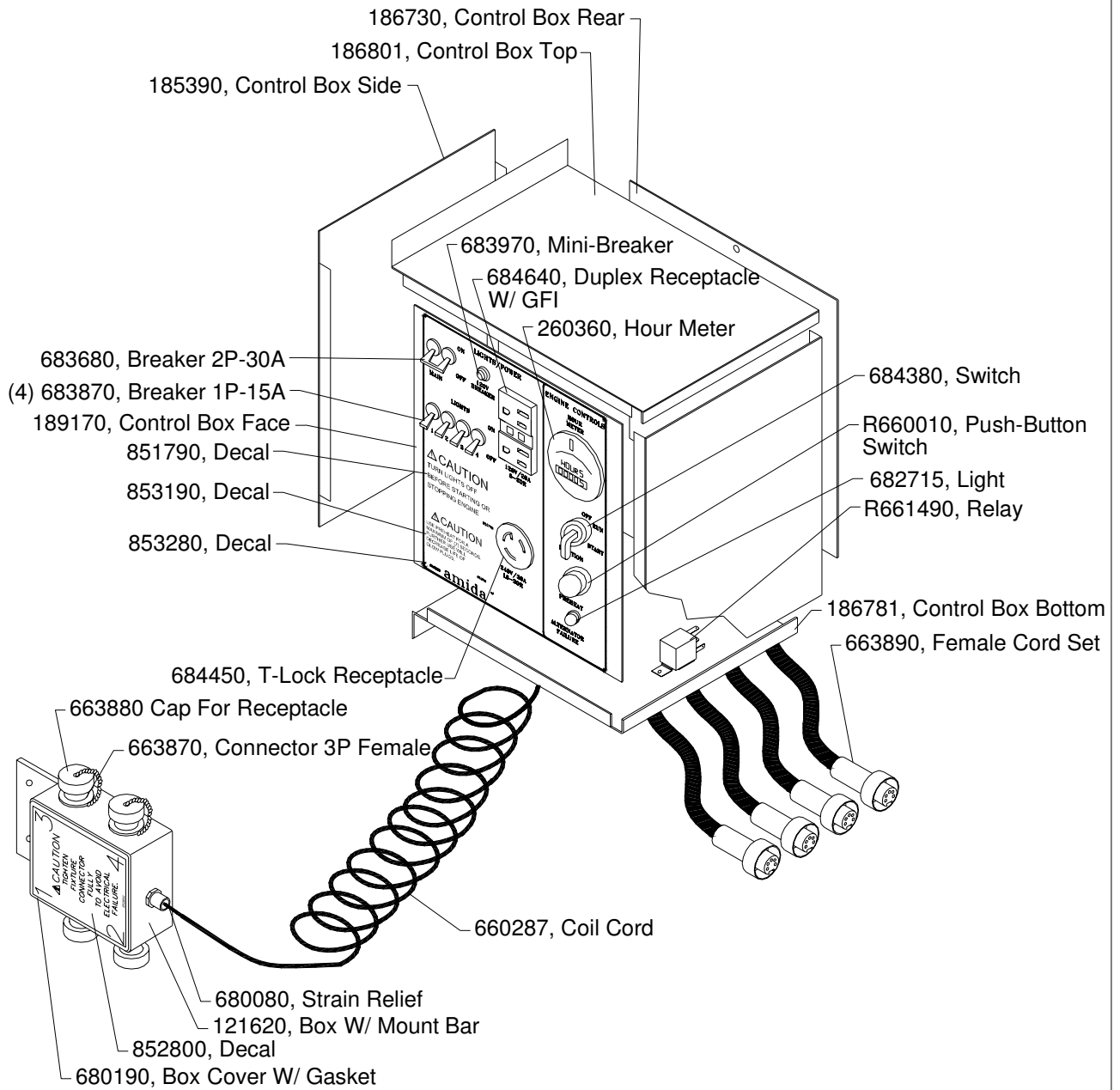

©Amida Industries, Inc. 1997

Created:	9-5-97	Revised:	a)	d)	Document:
By:	Spectrum		b)	e)	
			c)	f)	
			41		

112605-STANDARD LIGHT TOWER

MH/ MV/ HPS LIGHT FIXTURE

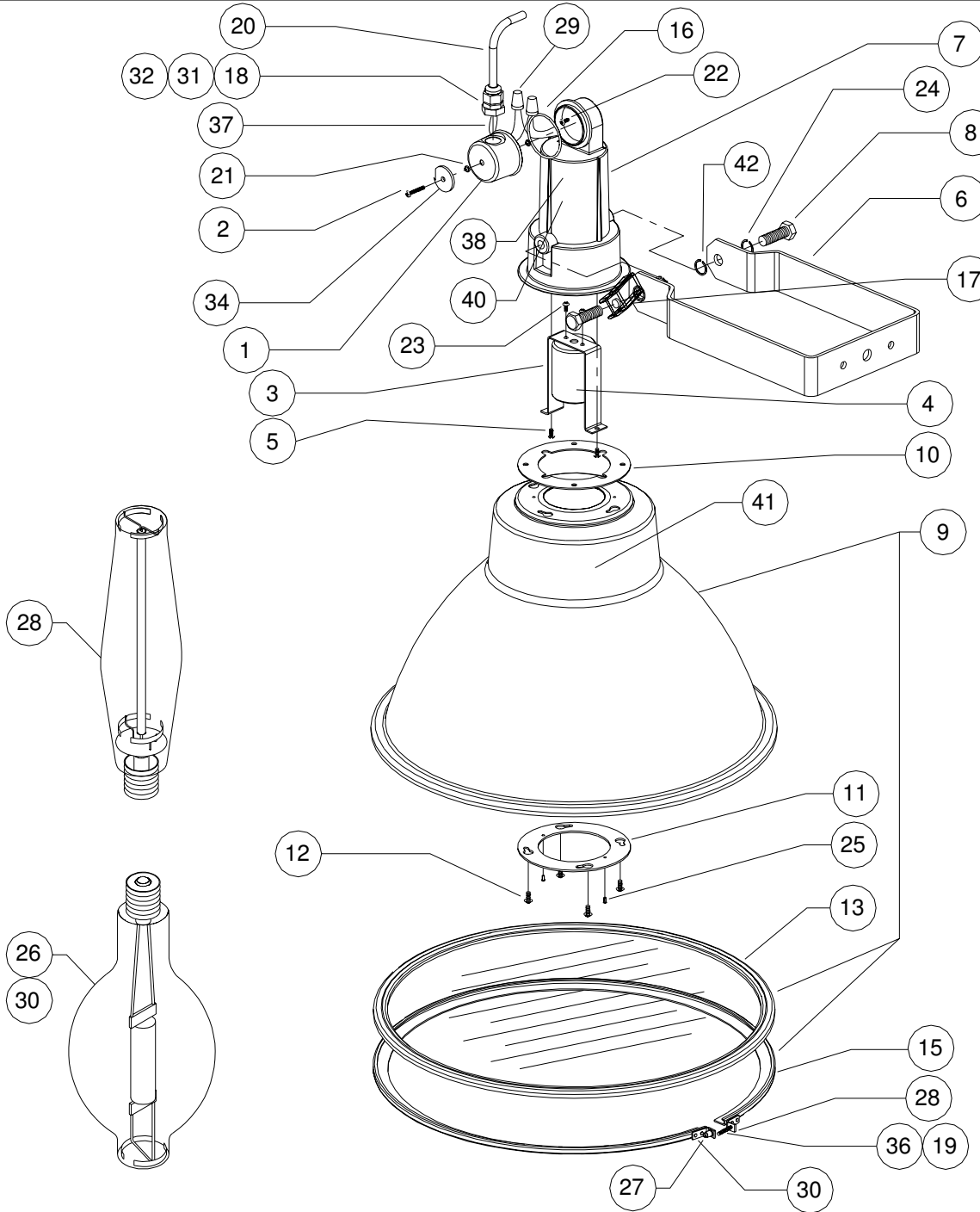

TEREX PART#	#	POWERLITE#	DESCRIPTION	QTY.
833561	1	410.0003	ALUM. CONNECTION BOX	1
833562	2	630.1045	SCREW 1/4-20 x 2" PH SS	1
833563	3	410.1023	SOCKET BRACKET (T&B 057-05-80643)	1
833564	4	4605079000	SOCKET MOGUL BASE W/ WIRES	1
833565	5	4106781000	SCREW 8-32 x 3/8" PH PH TT ZC	2
833566	6	410.1021	TRUNNION FOR GENERATOR	1
833567	7	310.0056	HOUSING ALUM. CST. FOR GENERATOR	1
990810	8	4103054000	BOLT 1/2-13 x 1-1/2" HH MS SS	2
833547	9	410.5021	REFLECTOR 18" ALUM. PEENED W/ LENS & BAND	1
833569	10	245.0120	GASKET HIF (T&B - B61178)	1
833570	11	410.1024	REINFORCING RING (T&B - B60198)	1
833571	12	70463	SCREW 10-24 x 5/8 HW SL TT	4
833524	13	245.0124 555.0079	VULCANIZED GASKET SILICONE - 1/8" LENS COMBINATION	1
833543	15	410.2027	CLAMP BAND Ø19.5" ALUMINUM	1
833572	16	245.0119	O-RING 1.925" ID x Ø0.103" SILICON	1
833573	17	410.1032	HANDLE FOR 1/2-13 BOLT (DWG) (OPTIONAL)	1
682470	18	690.0447	STRAIN RELIEF #2521 T&B	1
833574	19	630.8928	SCREW 8-32 X 1 HH SL MS SS	1
663850	20	84287	CORD #16-3 SIOW 105°C + 2 TERM. RING	1
833575	21	245.0121	O-RING 0.206" ID x Ø0.103 SILICON	2
833576	22	4107742000	SCRW 6-32"TT" X 3/8 PH PH ZN	1
833577	23	4106784000	SCREW 8-32 x 5/8" FH PH MS ZC	2
991650	24	4110310000	SPLIT WASHER 1/2 SS	2
990675	25	4104021000	RIVETS Ø1/8" ALUM. 3/16" LENGHT	2
160071	26		LAMP, 1000 WATT METAL HALIDE	1
833578	27	634.8005	NUTSERT 8-32 X Ø1/4" X 13/32" LENGHT	1
160140	28		LAMP, 1000 WATT HIGH PRESSURE SODIUM (OPT.)	1
833579	29	4100109000	MARRETS 150°C 2 WIRE NUT #16	2
160130	30		LAMP, 1000 WATT MERCURY VAPOR (OPT.)	1
683950	31	690.0446	SEAL RING .755" ID - EPDM	1
680020	32	634.0042	LOCKNUT 1/2	1
833580	34	635.1110	WASHER 1/4 X 1-1/4" OD	1
833581	36	4110953000	FIBER WASHER	1
833582	37	690.0121	FIBERGLASS SLEEVE 2-1/2"	.5
833583	38	791.2397	LBL WET LOCATION/EXTERIOR	1
833584	40	791.2395	LBL 105C SUPPLY COND.	1
833585	41	791.1137	LBL FIXTURE CSA - NRTL/C	1
995970	42	4110624000	WASHER 1/2 EXTER. TOOTH LOCK SS	2

NOTE:
FOR COMPLETE ASSEMBLY
ORDER PART# 112605

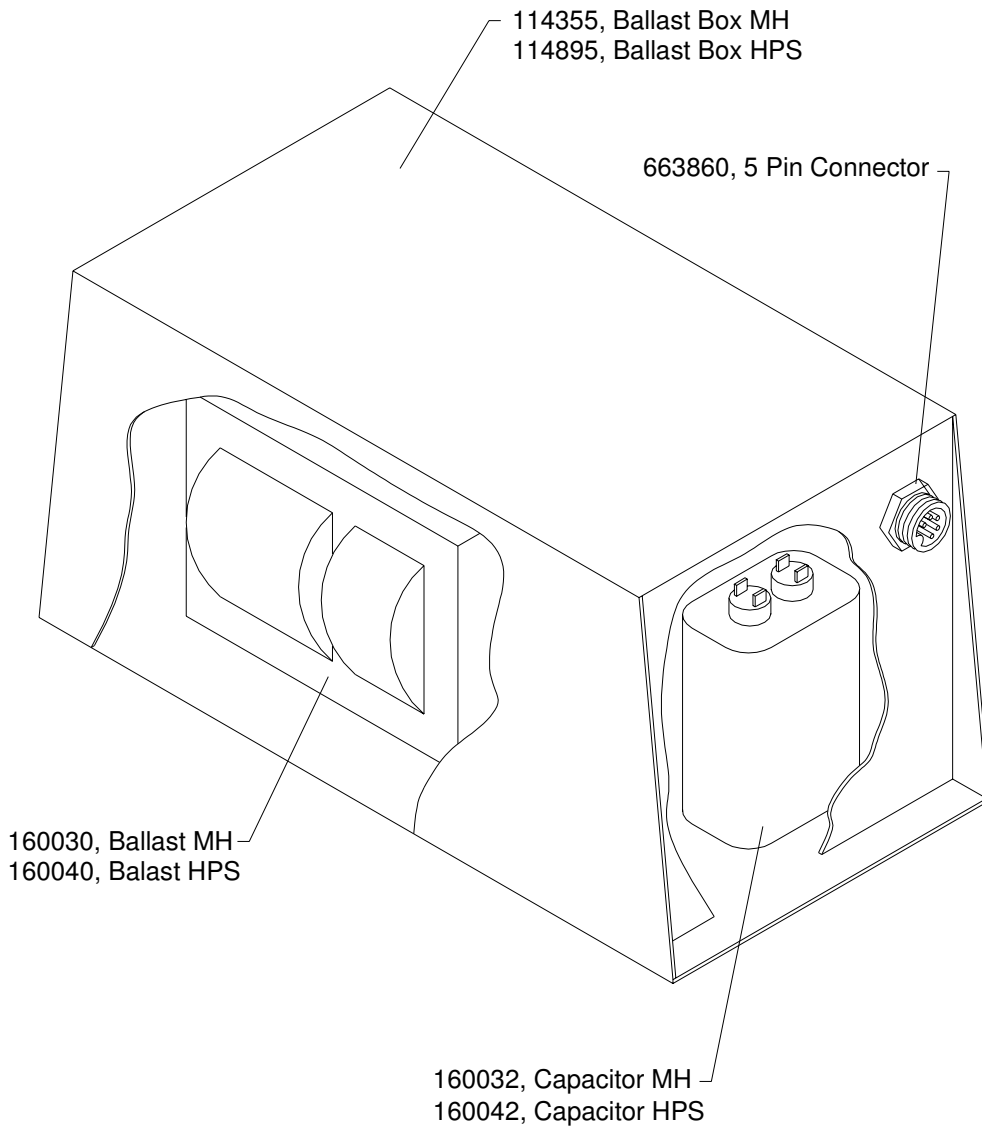

©Amida Industries, Inc. 1997



Model: AL4000 LIGHT TOWER

Page:

Title: Trailer Hitches

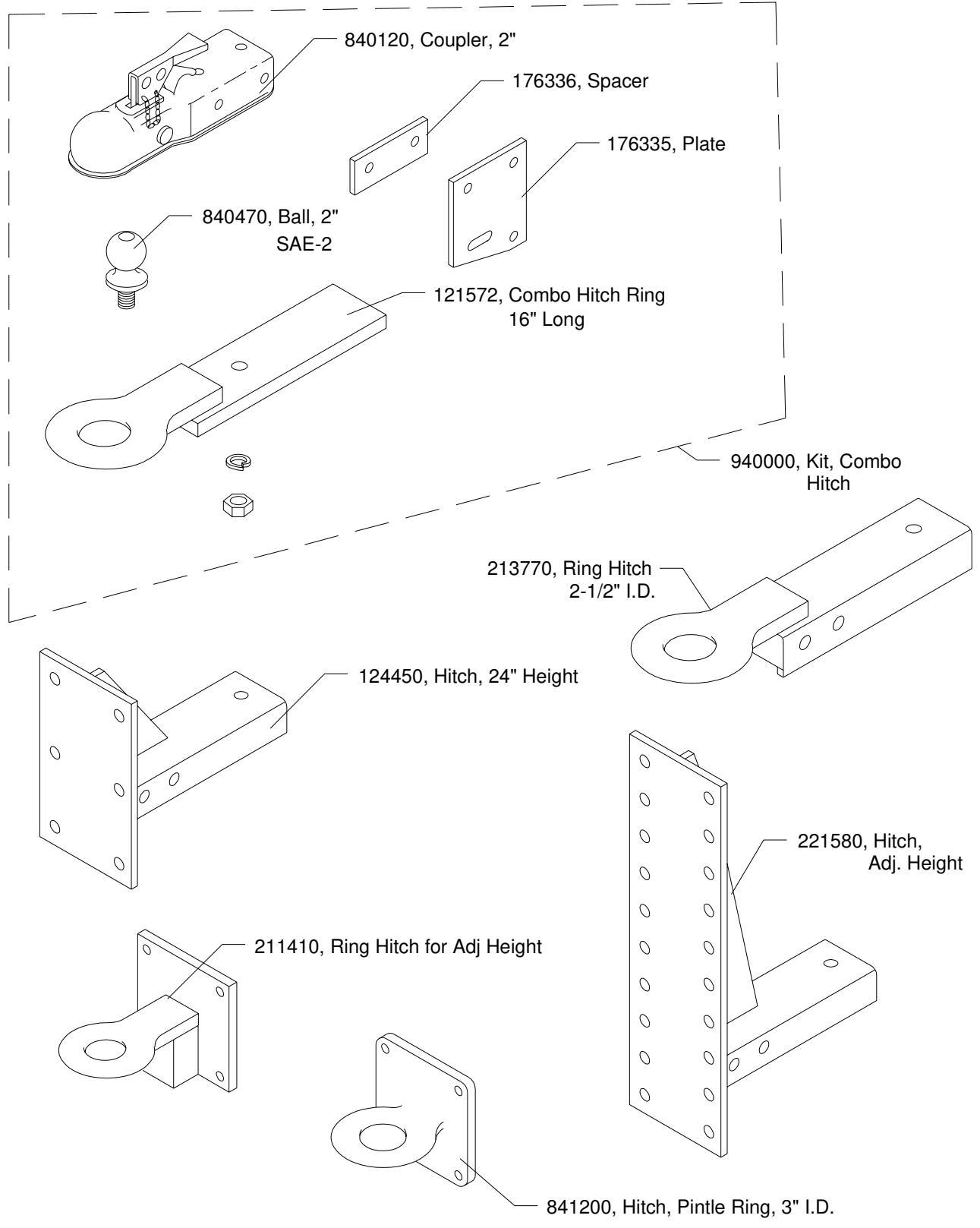

©Amida Industries, Inc. 1999

Created: 2-2-99

By: Spectrum

Revised: a) d)
 b) e)
 c) f)

Document:

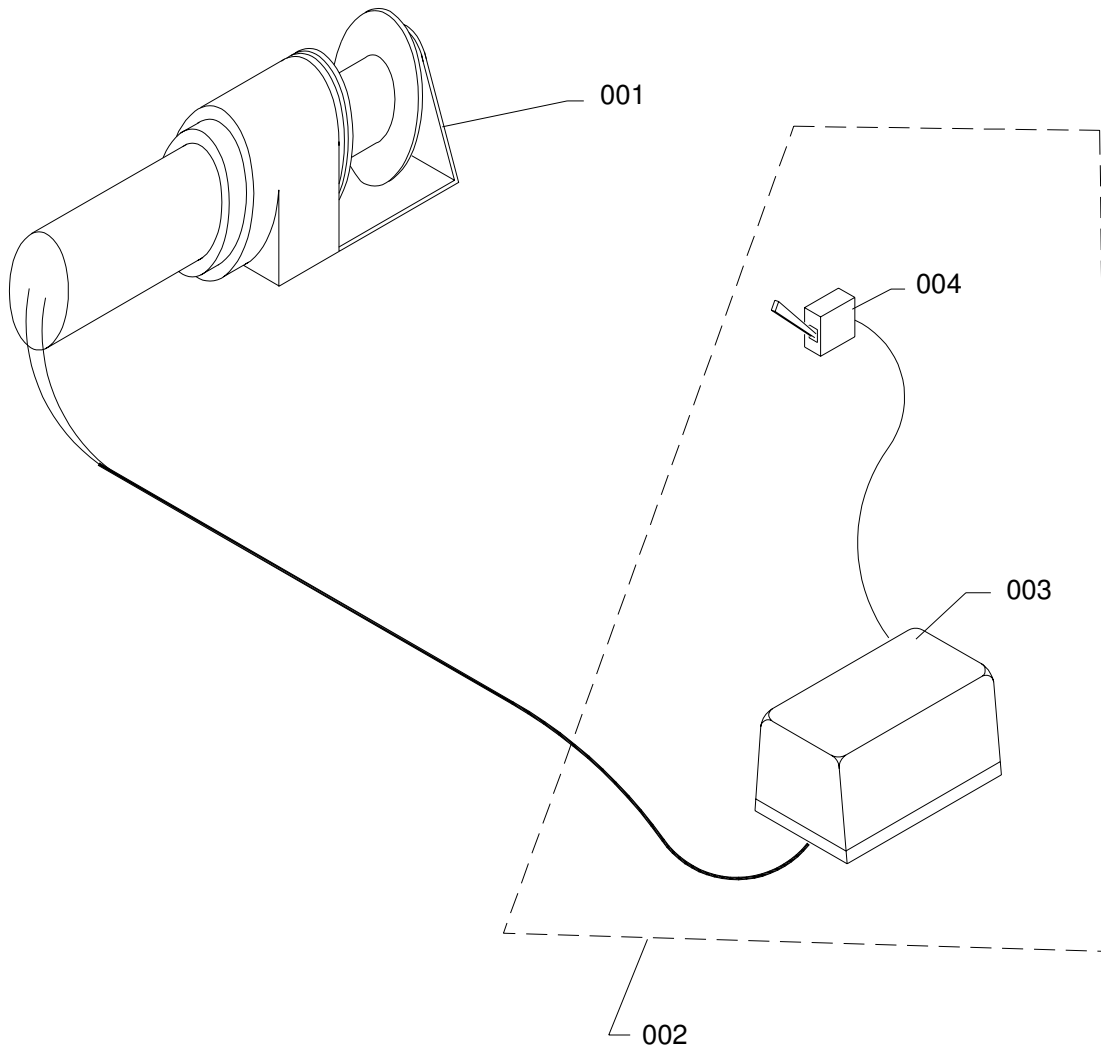

OPTION # 0LTX0690		WINCH, ELEC. 12V DC (STD) AL4000/LT5000	
DWG/ITEM #	PART #	DESCRIPTION	
001	160992	WINCH 12V	
002	113583	WINCH SWITCH W/ SOLENOID ASS'Y	
003	160993	WINCH SOLENOID	
004	663780	WINCH TOGGLE SWITCH	
DRAWN BY	BLB	DATE	2/8/96
		DRAWING NO.	8149

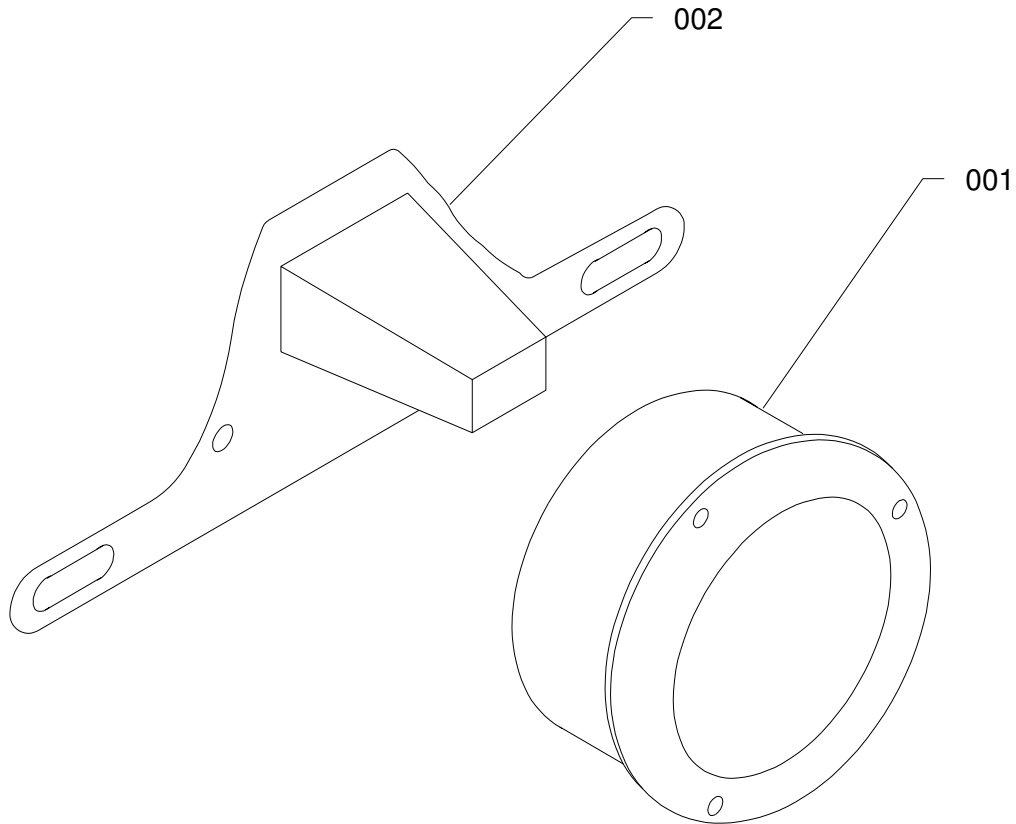

OPTION # 0LTX0080 STOP TAIL & TURN LIGHT AND LICENSE TAG LIGHT

DWG/ITEM #	PART #	DESCRIPTION
8126 - 001	663510	STOP TAIL & TURN LIGHT
8126 - 002	663520	LICENSE TAG LIGHT W/BRACKET
DRAWN BY	CNM	DATE 4/4/91
		DRAWING NO. 8126

PART# WD2985		DWG.# 2985A	
ITEM#	PART#	DESCRIPTION	#REQ

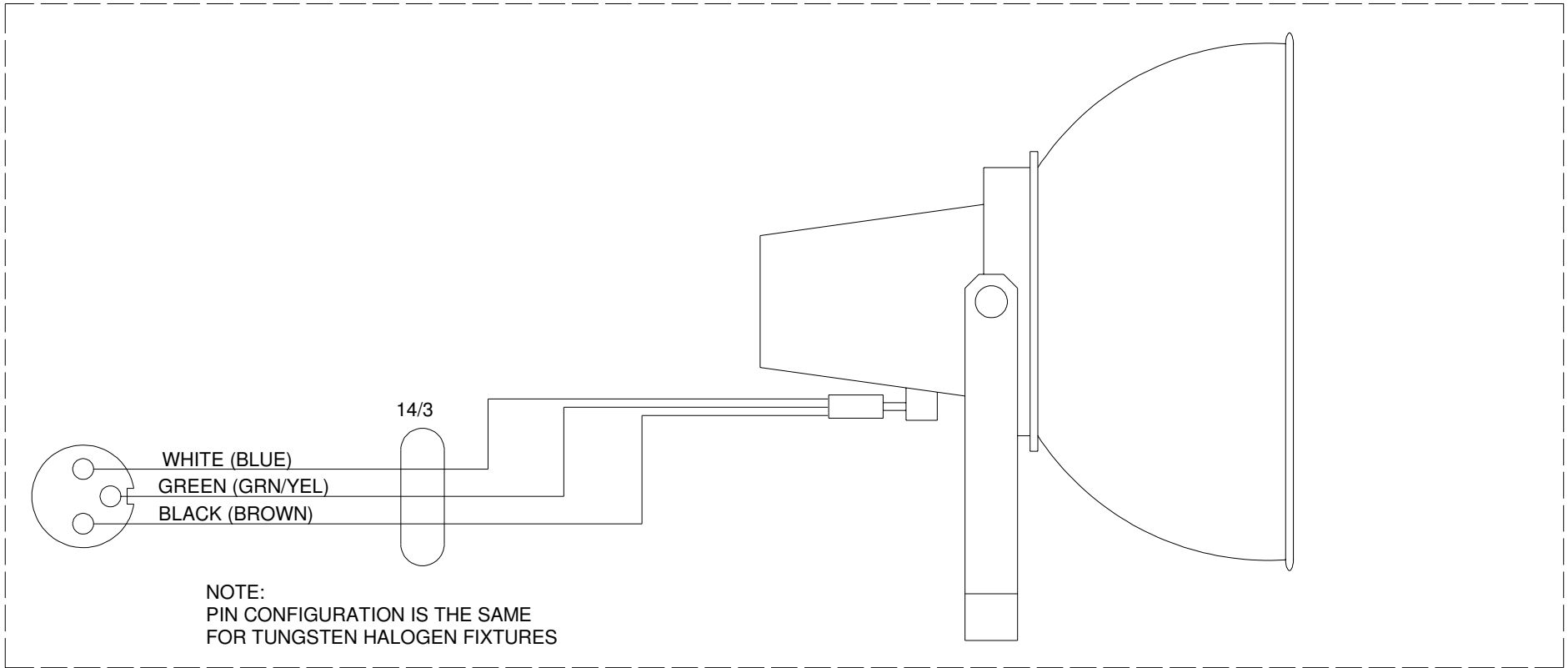

47

DOMESTIC
COLOR
CODE

WHITE
BLACK
GREEN

EUROPEAN
COLOR
CODE

LIGHT BLUE
BROWN
GREEN W/YELLOW

CIRCUIT

COMMON FROM BALLAST
HOT FROM BALLAST (LIVE)
GROUND (EARTH)

A	3/15/00		ADDED EUROPEAN (CE) WIRING DATA	
REV.	DATE	ECO #	CHANGE	
TOLERANCES UNLESS OTHERWISE SPECIFIED:			<h2 style="text-align: center;">Terex-amida</h2> <p style="text-align: center;">590 HUEY Rd, ROCK HILL, S.C. Ph. (803) 324-3011 FAX 366-1101</p>	
Fractions ±1/16				
Decimals .XX=±.030 .XXX=±.010 .XXX=±.005 Degrees ±1/2°				
REMOVE ALL BURRS & SHARP EDGES			WIRING DIAGRAM, MH OR HPS FIXTURE	
MATL.			W/JOY CONNECTOR	BORDER "B"
MAT P/N			DR BY	SCALE NONE
PLOT 4/30/91		DATE 4/30/91	PART# WD2985	DWG.#2985A

PART#	WD2986	DWG.#	2986
ITEM#	PART#	DESCRIPTION	#REQ

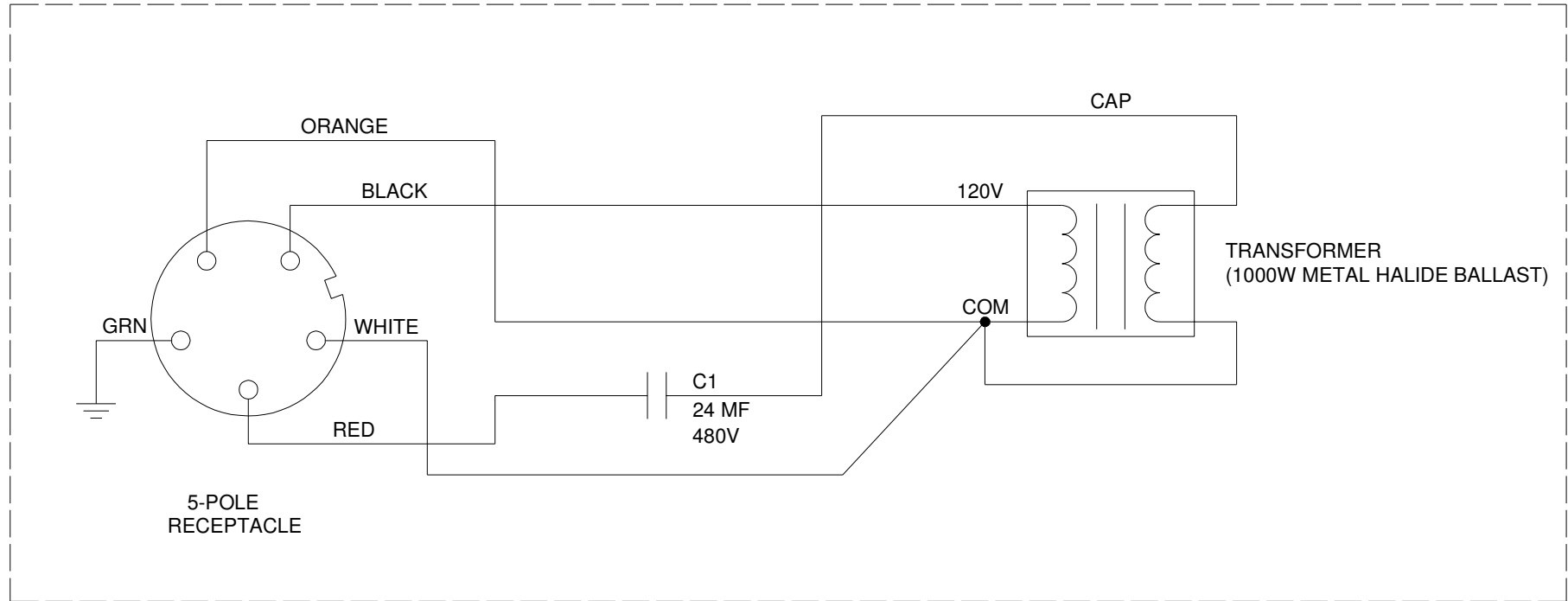

48

<u>COLOR</u>	<u>CIRCUIT</u>
BLACK	INPUT 120V
WHITE	INPUT COMMON
RED	LAMP HOT
ORANGE	LAMP COMMON
GREEN	GROUND

REV.	DATE	ECO #	CHANGE
TOLERANCES UNLESS OTHERWISE SPECIFIED: Fractions $\pm 1/16$ Decimals $.XX = \pm 0.030$ $.XXX = \pm 0.010$ $.XXXX = \pm 0.005$ Degrees $\pm 1/2^\circ$			Terex-amida 590 HUEY Rd, ROCK HILL, S.C. Ph. (803) 324-3011 FAX 366-1101
REMOVE ALL BURRS & SHARP EDGES			
MATL. MATL		W / JOY CONNECTOR	BORDER "B"
MAT P/N	USAGE	DR BY: CNM	SCALE: NONE
PLOT: 4/30/91	DATE: 4/30/91	PART# WD2986	DWG.# 2986

PART# WD2987		DWG.# 2987	
ITEM#	PART#	DESCRIPTION	#REQ

49

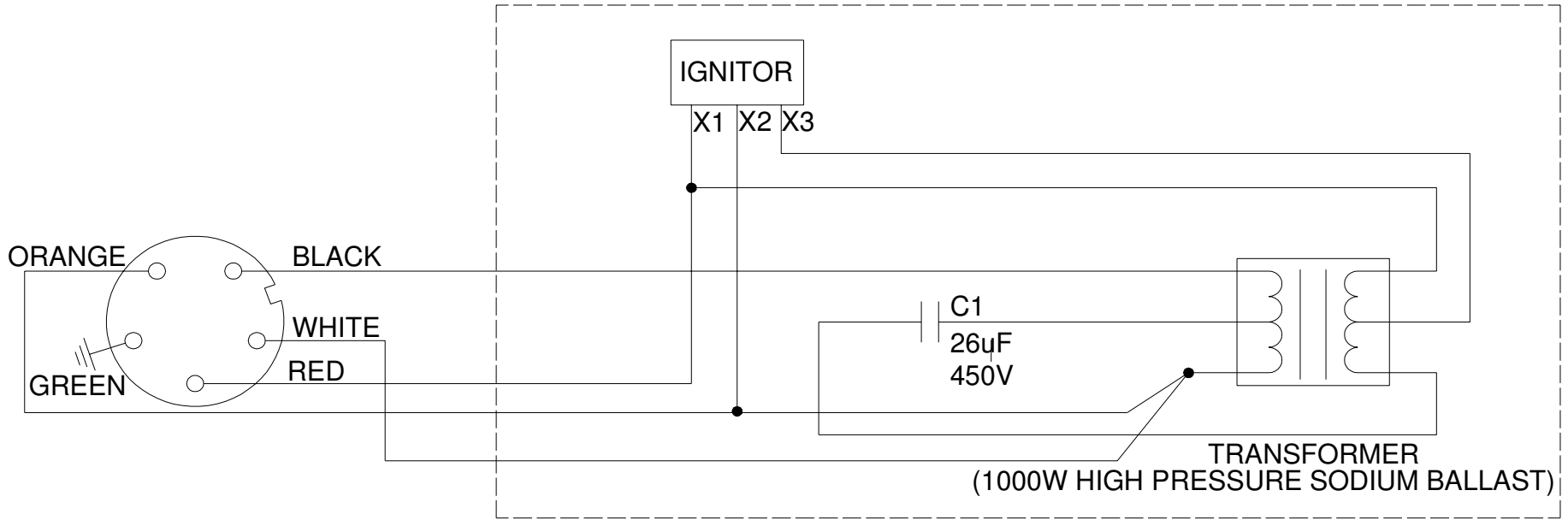

5-POLE
RECEPTACLE

<u>COLOR</u>	<u>CIRCUIT</u>
BLACK	INPUT 120V
WHITE	INPUT COMMON
RED	LAMP HOT
ORANGE	LAMP COMMON
GREEN	GROUND

REV.	DATE	ECO #	CHANGE	
TOLERANCES UNLESS OTHERWISE SPECIFIED:			<h1 style="text-align: center;">Terex-amida</h1> <p style="text-align: center;">590 HUEY Rd, ROCK HILL, S.C. Ph. (803) 324-3011 FAX 366-1101</p>	
Fractions ±1/16 Decimals .XX=±.030 .XXX=±.010 .XXXX=±.005 Degrees ±1/2°				
REMOVE ALL BURRS & SHARP EDGES			WIRING DIAGRAM - 1000HPS BALLAST	
MATL. MATL		W / JOY CONNECTOR		BORDER "A"
MAT P/N		USAGE		SCALE: NONE
PLOT: 4/30/91		DATE: 4/30/91		PART# WD2987 DWG.# 2987

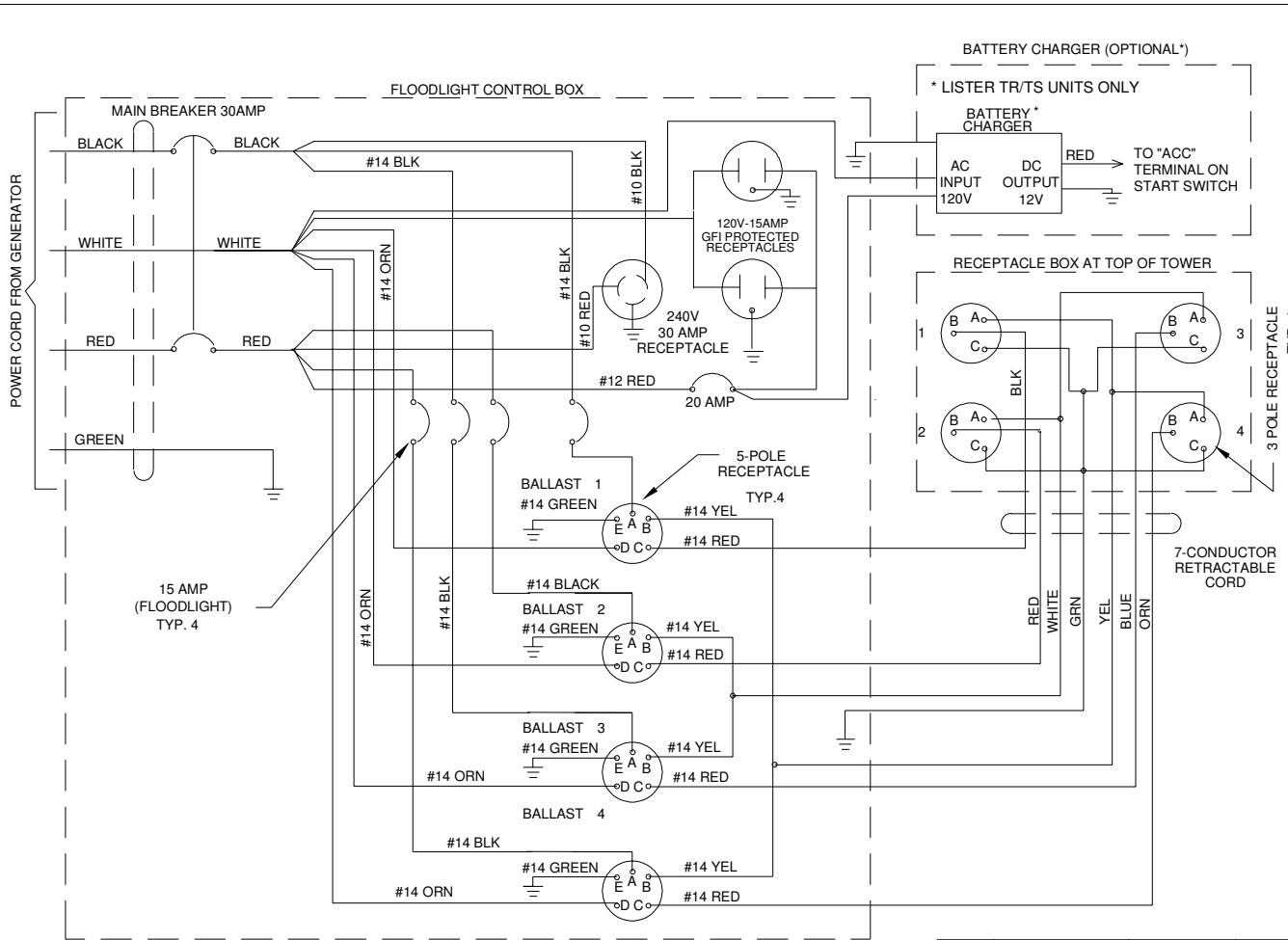

PART#	WD2763	DWG.#	2763B
ITEM#	PART#	DESCRIPTION	#REQ

REV.	DATE	ECO #	CHANGE	
TOLERANCES UNLESS OTHERWISE SPECIFIED:			Terex-amida 590 HUEY Rd, ROCK HILL, S.C. Ph. (803) 324-3011 FAX 366-1101 WD-AC CONTROL BOX, 4MH/HPS	
Fractions ±1/16				
Decimals .XX=±.030 .XXX=±.010				
.XXXX=±.005				
Degrees ±1/2°			REMOVE ALL BURRS & SHARP EDGES	
MATERIAL		AL4/AL5/LT5/SL4	BORDER "B"	
MAT P/N		USAGE	DR BY GMB	SCALE NONE
PLOT 7/9/93		DATE 7/9/93	PART# WD2763	DWG.#2763B

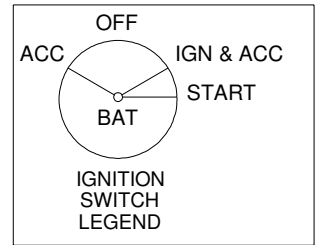
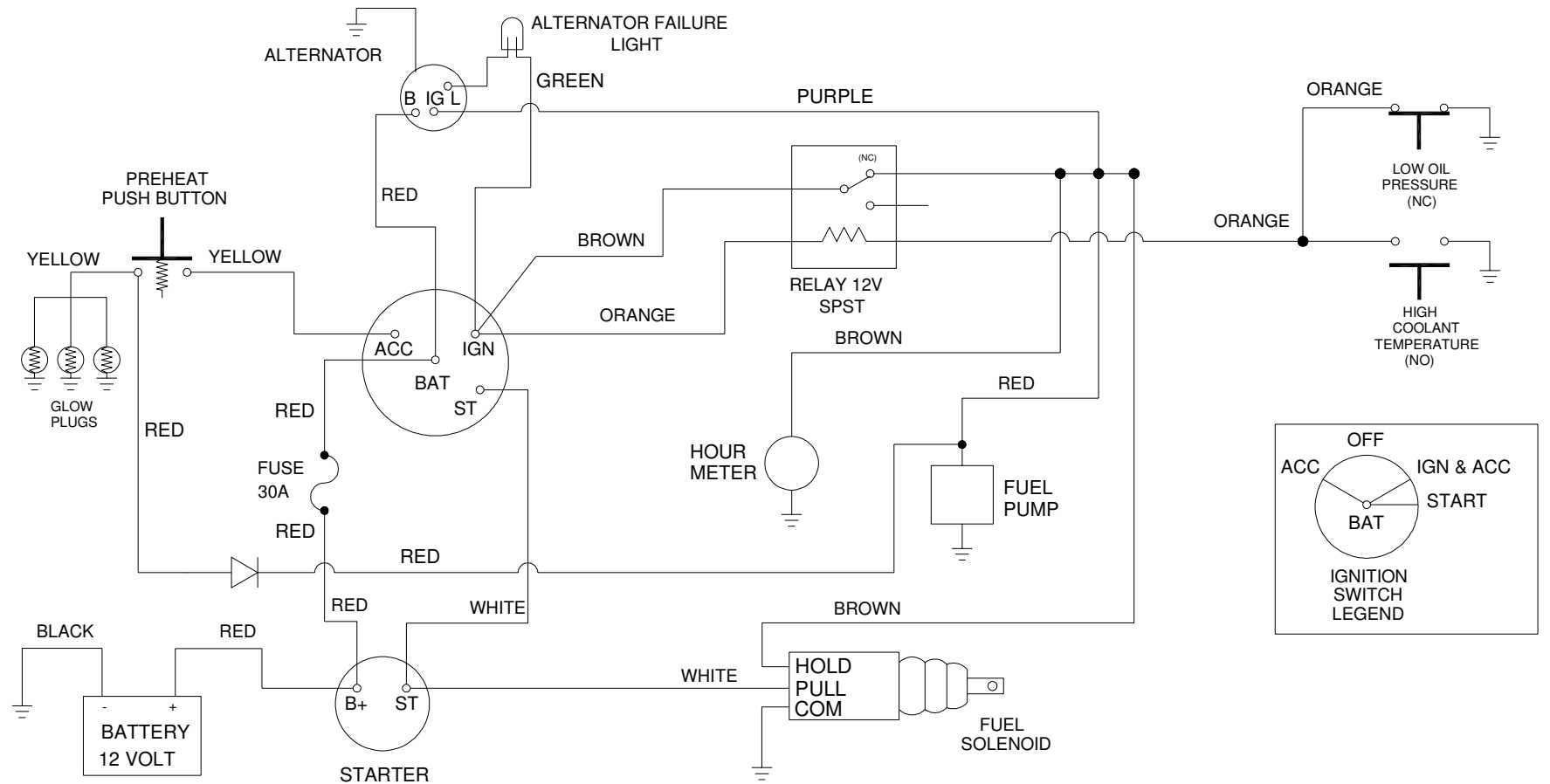

51

E	1/12/01	ECO #	ADDED DIODE FOR FUEL PUMP/ PRIME	
REV.	DATE	ECO #	CHANGE	
TOLERANCES UNLESS OTHERWISE SPECIFIED:			Terex-amida 590 HUEY Rd, ROCK HILL, S.C. Ph. (803) 324-3011 FAX 366-1101 WD - DC ENGINE WIRING, KUBOTA	
Fractions ±1/16				
Decimals .XX=±.030 .XXX=±.010				
.XXXX=±.005				
Degrees ±1/2°				
REMOVE ALL BURRS & SHARP EDGES				
MATL.		D905, AL4, AL5, TX3	BORDER "B"	
MAT. P/N	USAGE	DR BY JCS	APP BY	SCALE N/A
PLOT B 3/23/00	DATE 3/23/00	PART# WD4730	DWG.# 4730E	

**TEREX Amida Model AL4000
Light Tower – General Specifications
And Routine Maintenance**

TEREX Amida model AL4000 series light tower provides mobile; trailer mounted floodlighting for nighttime maintenance, construction, mining, and emergency work. It consists of a trailer with a diesel powered 6 kW 60Hz (50 Hz units available) generator, and a 30 foot cable actuated tower with four (4) 1000 watt floodlight fixtures. It is ideally suited for heavy-duty use and is built to meet the following specification:

DIMENSIONS

Overall length, travel position w/fixtures & tongue	179”	(4547 mm)
Overall length, tower vertical w/tongue & jacks	124”	(3150 mm)
Trailer frame length	70”	(1778 mm)
Overall height, floodlighting position	30’	(9.14 mm)
Overall height, travel position	68”	(1727 mm)
Overall width with fenders	61”	(1549 mm)
Overall width with outriggers pulled out	102”	(2591 mm)
Trailer frame width	41”	(1041 mm)
Tongue length	44”	(1118 mm)
Wheel size	15”	(381mm)
Axle Rating	3500 lb.	(1588 kg)
Tongue weight travel position	100 lb.	(45.4 kg)
Total weight no fuel	2050 lb.	(930 kg)
Fuel Capacity	30 gal.	(1141)
Unit weight with full fuel tank	2250 lb.	(1020 kg)

This section details specifications and maintenance not covered in the operators and trouble-shooting sections of this manual and the AL4000 specification sheets.

OIL / AIR SERVICE

The engine oil should initially be changed after the first 50 hours of use and then every 200 hours thereafter. The oil filter should be replaced after every 400 hours of use. The air filter element should be replaced once every year, or after six cleanings (see manufacturer’s operation manual for details).

BRAKE SYSTEM

Electrical or mechanical brakes are not standard equipment on the AL4000. Contact your dealer or the factory for option information.

MANUAL WINCH

Maintain a light film of automotive-type grease on the pinion, drum gear, and the O.D. of the drum bearing at all times. Keep the ratchet pawl pivot, pinion shaft bushings, and pinion threads lubricated with automotive engine oil at all times. **WARNING:** Before each use, check the brake friction discs for wear. If less than 1/16" thick, cracked, or broken, replace **IMMEDIATELY**. Ratchet pawl should "click" when tower is raised, and not when it is lowered. **WARNING...CAUTION:** Always be alert for any fraying of cables, and replace any damaged cables **IMMEDIATELY**. Never stand under any object lifted by the winch.

ELECTRIC WINCH

The electric winch is permanently sealed and does not need any periodic lubrication. **WARNING...CAUTION:** Always be alert for any fraying of cables, and replace any damaged cables **IMMEDIATELY**. Never stand under any object lifted by the winch.

RECEPTACLE POWER TABLE

METAL HALIDE/ HIGH PRESSURE SODIUM

STATUS	RECEPTACLE POWER AVAILABLE 120/240 VAC	
LIGHTS ON	DUPLEX W/FI	240V- 30A REC.
ALL OFF	15 AMPS*	30 AMPS*
1 OR 3	15 AMPS*	16.6 AMPS
2 OR 4	15 AMPS*	16.6 AMPS
1 AND 3	15 AMPS*	8.3 AMPS
2 AND 4	8.3 AMPS	8.3 AMPS

TUNGSTEN HALOGEN

STATUS	RECEPTACLE POWER AVAILABLE 120/240 VAC	
LIGHTS ON	DUPLEX W/FGI	240V- 30A REC.
ALL OFF	15 AMPS*	30 AMPS*
1 OR 3	15 AMPS*	17 AMPS
2 OR 4	15 AMPS*	17 AMPS
1 AND 3	15 AMPS*	10 AMPS
2 AND 4	15 AMPS*	10 AMPS

- There is more current available than listed. The rating of the duplex receptacle is 15 amps.

NOISE LEVEL

Mean SPL (sound pressure level) hemispherically at 7 meters:

62.01dBA

Sound Power Level (62.01dBA + 20 log d + 7.8):

90.0 LWA re 1 pW

D = 7 meters

MISCELLANEOUS SPECIFICATIONS

The Amida AL4000 light tower is built to NEC standards.

FASTENER TORQUE SPECIFICATIONS

All fasteners should be torqued to the following specifications in lb-ft (lb-in):

FASTENER SIZE UNF & UNC	STAINLESS STEEL*	STAINLESS STEEL* NYLOK NUT	SAE GRADE 5 PLATED (METRIC 8.8)	SAE GRADE 5 PLATED NYLOK NUT	SAE GRADE 8 PLATED (METRIC 10.9)	SAE GRADE 8 PLATED NYLOK NUT
#6	(10-12)	(8.5-10)	(14-16)			
#8	(20-22)	(17-19)	(25-28)			
#10	(26-32)	(22-27)	(40-45)			
1/4"	(75-94)	(64-80)	7-9		12-14	
5/16"	12-Nov	14-Dec	15-17		23-26	
3/8"	20-22	22-24	28-34		45-50	
7/16"	31-33	32-35	40-45		70-75	
1/2"	43-45	45-50	75-85	70-80	100-110	95-105
9/16"	57-63	60-65	80-100	75-95	145-160	135-150
5/8"	92-104	100-105	130-170	125-165	175-205	165-195
3/4"	128-135	140-150	220-240	205-225	380-420	365-405
4mm	(22-26)	(19-22)	(23-27)			
6mm	(45-50)	(38-43)	(72-78)			
8mm	12-Nov	9-10	14-16			
10mm	18-20	15-17	45-50	40-45	70-75	
12mm	42-44	36-38	56-60	50-55	95-105	
16mm			140-148			
18mm			185-200			
20mm			280-290			

* An anti-seize lubricant MUST be used on all stainless steel hardware.

WIND LOADING CHARACTERISTICS

All wind load calculations were performed with the winch at 12 o'clock, the wind coming from the direction shown with the lights flat-facing into the wind.

WIND DIRECTION	SPEED
FROM 12 O'CLOCK	78 MPH
FROM 1 & 11 O'CLOCK	83.8 MPH
FROM 2 & 10 O'CLOCK	92 MPH
FROM 3 & 9 O'CLOCK	66 MPH
FROM 4 & 8 O'CLOCK	62 MPH
FROM 5 & 7 O'CLOCK	84 MPH
FROM 6 O'CLOCK	90 MPH

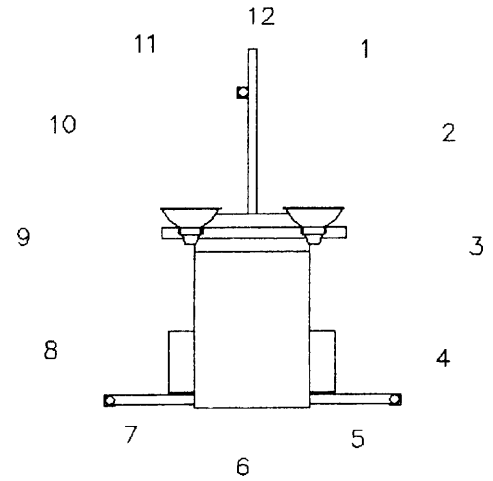

NOTE:

If optional front outriggers are used, the allowable wind loading in the 3 and 9 o'clock directions is 79 mph. In the 4 and 8 o'clock directions, the allowable wind velocity would be 94 mph.

BROKEN CABLE REPLACEMENT PROCEDURE

1. PREPARATION

- 1.1 Collapse tower to where mast is retracted, then pivot tower to horizontal position.
- 1.2 Remove the tower from the trailer and place it on a work surface such as two saw horses.

2. REMOVING TOP CABLE AND TOP MAST SECTION

- 2.1 Tie middle section and large section together by wrapping band, cable, chain, or rope around the sheave brackets on these two sections. This insures that the middle section stays inside the large section during removal of the small section.
- 2.2 Remove or lock the telescope lock pin open. This is the pin that locks the three sections together during travel.
- 2.3 Drill out the aluminum pop rivets holding the plastic guides at the top of the middle section. Using a screwdriver, remove these guides.
- 2.4 Remove the clevis pin anchoring the cable to the top of the middle section and remove the clevis pin and the sheave from the middle section.
- 2.5 Pass the free end of the cable through the sheave slot between the middle and small section, and out of the top of the tower. Pull the cable and the small section completely out of the middle section together. Be sure to keep the cable tight; if slack accumulates it is most difficult to remove.
- 2.6 Unfasten the cable by removing the bolt at the base of the small section.

3. REINSTALLING THE SMALL SECTION

- 3.1 Fasten new cable to the base of the small section.
- 3.2 Reversing the procedure described in steps 2.1 through 2.5, reinstall the small section.
- 3.3 Reinstall the plastic guides with new pop rivets. New plastic guides should be used, but the old guides can be used if their mounting position is shifted to the point where new holes can be drilled in the tower section to provide a good fit when installing new pop rivets.

4. REMOVING THE LOWER CABLE AND MIDDLE TOWER SECTION

- 4.1 Remove or lock open the telescope lock pin if not previously done in step 2.2.
- 4.2 Drill out the aluminum pop rivets holding the plastic guides at the top of the large section. Using a screwdriver, remove these guides.
- 4.3 Remove the cable from winch drum.
- 4.4 Remove the sheave clevis pin and the sheave from the top of the large section.
- 4.5 If the old cable is not frayed between the winch and the bottom mast pulley, attach a flexible "fish wire" or "snake" (wire, rope cord, etc.) to the end of the cable to be used to thread the new cable through the lower tower and pulleys. This can be done by "untwisting" the cable and inserting the wire or cord into the middle of the cable and thus letting the cable twist back tightly around the fish wire. If the old cable is frayed, cut off the frayed portion and proceed as above and then remove tower and cable as instructed in section 4.6.

- 4.6 Pass the free end of the cable through the sheave slot between the large and middle sections and out of the top of the tower. Pull the cable and the middle section completely out of the large section altogether. Be sure to keep the cable tight, if slack accumulates it is most difficult to remove.
- 4.7 If the fish wire doesn't work, it is necessary to remove the square mast section from the round mast section. Remove the pivot pin from the pivot post and lift the mast from the pivot post and place the assembly on a work surface. Remove the hex nut from the bottom of the round section, remove the "T" bolt at the top of the round section, and pull the square mast assembly out of the round section, and proceed as instructed in section 4.6.
- 4.8 Unfasten the cable by removing the bolt at the base of the middle section.

5. REINSTALLING THE LOWER CABLE AND MIDDLE SECTION

- 5.1 If the "fish wire" worked, attach the cable to the fish wire and pull through the pulleys and the round section.
- 5.2 If the square tower section was removed from the round section, thread the cable through the pulleys at the bottom of the large section and out of the tubular stud. Reinstall the large square section into the round section. Install the "T" locking bolt, and the hex nut on the bottom of the round section. The hex-locking nut should be tightened and then backed off approximately one-half turn or until the tower rotates freely.
- 5.3 Fasten the new cable to the base of the middle section.
- 5.4 Reversing the procedures detailed in sections 4.4 through 4.7, reinstall the middle section.
- 5.5 Fasten the new cable to the winch drum.
- 5.6 Reinstall the plastic shims as described in section 3.3.

LIGHT FIXTURE TROUBLESHOOTING

DANGER! Do not open fixtures while light circuit breaker is “ON”. Allow lamp to cool before touching.

****TAKE EXTRA PRECAUTIONS WHEN TROUBLESHOOTING ELECTRICAL PROBLEMS****

- A. Only use a voltmeter with two well-insulated pin probes rated for 600 volts.
- B. Treat all conductors as potentially hot.
- C. Proceed through circuits systematically, operating only one section at a time.
- D. Before disconnecting ballast, turn off circuit breaker and wait 30 seconds for capacitor to discharge.
- E. If all the lights are out and all the ballasts are receiving power, suspect burned out power cable.

SYMPTOM	CAUSES	CORRECTIVE ACTION
LAMP WILL NOT START	Check Ballast Status Light	<ul style="list-style-type: none"> a. Input lights should be on. This confirms power is going to the ballast. b. Output lights should be on. This confirms power is coming from ballasts. c. Output lights should be normal brightness. If one or more of the output lights stay extra-bright, then the lamp is not striking. d. Use this knowledge to diagnose problem. e. If ballast status light is out, but the floodlight lamp is working, suspect burned out ballast status lamp and replace
	Lamp loose in socket	Inspect lamp base to see if there is arcing at center contact button. Tighten lamp snugly. Check socket for damage. Replace if defective.
	Floodlight Plugs not tight Defective Ballast	Check plug and receptacle. Tighten if loose. Interchange ballast plugs in generator enclosure. If lamp starts, replace ballast. Check ballast wiring diagram. Check for swollen capacitors, charred wiring, core and coil, or other signs of excessive heat.
	Low Voltage	Check line voltage at ballast input. Voltage should be within 10% of nameplate rating when operating at normal load. Increase supply voltage or remove external load.
	Improper ballast	Proper HID lamps will perform erratically or fail to start on an improper ballast. The ballast nameplate data should agree with the line voltage and lamp used. Improper ballast will cause lamp to fail.
	Improper lamp operating position	Operating position should agree with lamp etch. A BUHOR lamp can be operated base up vertical to and including the horizontal and BD can be operated base down and vertical to, approaching, but not including the horizontal. A lamp operated beyond the specified position may not start.
	Lamp has been operating; cool down time insufficient	HID lamps require 4 to 8 minutes cool-down time before restarting. Switch off breaker and allow lamp to cool.

LIGHT FIXTURE TROUBLESHOOTING (cont'd)

SYMPTOM	CAUSES	CORRECTIVE ACTION
LAMP STARTS SLOWLY (ARC DOES NOT STRIKE WHEN SWITCH IS FIRST TURNED ON)	Defective Lamp	Lamp may glow for extended period of time. Replace after checking voltage and ballast.
CIRCUIT BREAKER TRIPS ON LAMP START-UP	Short circuit or ground	Checking wiring against diagram. Check for shorts or ground.
LAMP LIGHT OUTPUT LOW	Normal lamp depreciation	Replace lamp
	Dirty lamp or fixture	Clean lamp and fixture
	Defective ballast	Interchange ballast plugs in generator enclosure. If lamp returns to normal light output, replace ballast. Check for swollen capacitors, charred wiring, core and coil, or other signs of excessive heat.
	Wrong Voltage	Check voltage at ballast input. Voltage should be within 10% of nameplate rating. Check wiring connections for voltage loss. Check socket contact point.
	Improper ballast	Check ballast nameplate against lamp data.
LAMP COLORS DIFFERENT	Normal lamp depreciation	Lamp color and brightness decreases and colors change slightly as lamps age. Spot replacement with new lamps may cause noticeable differences in lamp colors. Group replacement minimizes color differences.
	Dirty fixture	Dirty fixtures will cause lamps to appear different in color. Clean fixture.
	Wrong lamp	Check data on lamps, which appear different in color. Replace with correct color lamp.
ARC TUBE DISCOLORED OR SWOLLEN	Over voltage from power supply	Check voltage at ballast. Check for current or voltage surges. Check for shorted capacitors and replace if defective.
	Improper ballast	Lamp operated on ballast designed for higher wattage lamp. Check ballast nameplate against lamp data.

LIGHT FIXTURE TROUBLESHOOTING (cont'd)

SYMPTOM	CAUSES	CORRECTIVE ACTIONS
SHORT LAMP LIFE	Lamp damaged	Check for outer bulb cracks. If air enters outer bulb, arc tube may continue to burn for 100 hours before failure. Check for bulb cracks where glass meets the base due to tightening lamp too firmly in socket. Look for broken arc tube or loose metal parts. Replace lamp.
	Improper ballast	Ballast nameplate data should agree with lamp line voltage and lamp use. If improper ballast is used, the lamp life will be shortened. A mismatch may also cause the ballast to fail.
LAMP FLICKERS AND GOES OUT INTERMITTET	Improper ballast	Improper ballasting can cause flickering or erratic operation. In the start-up period the lamp may ignite, start to warm-up and then extinguish (cycle).
	New lamp	Under certain conditions new lamps may “cycle”. Usually after three (3) tries to start at 30 to 60 second intervals, lamps will stabilize and operate satisfactorily.
	Defective lamp	Replace lamp.
	High spike ballast	Ballast produce high spike current. Measure with oscilloscope. Replace ballast as required.

TRACEABLE NUMBERED WIRING SYSTEM

(Using plug in ballasts to troubleshoot)

When troubleshooting the preceding problems, minimize down time by following the traceable numbered wiring system, always follow these steps:

STEP1: Insure all ballasts, which are numbered, are plugged into lead wires with corresponding numbers.

STEP 2: Looking at the lights from the glass side and following the diagram below, plug each fixture into the appropriately numbered plug at the top of the tower.

By adhering to the traceable numbered wiring system, troubleshooting, fixture aiming, and fixture control will follow a standard predictable pattern.

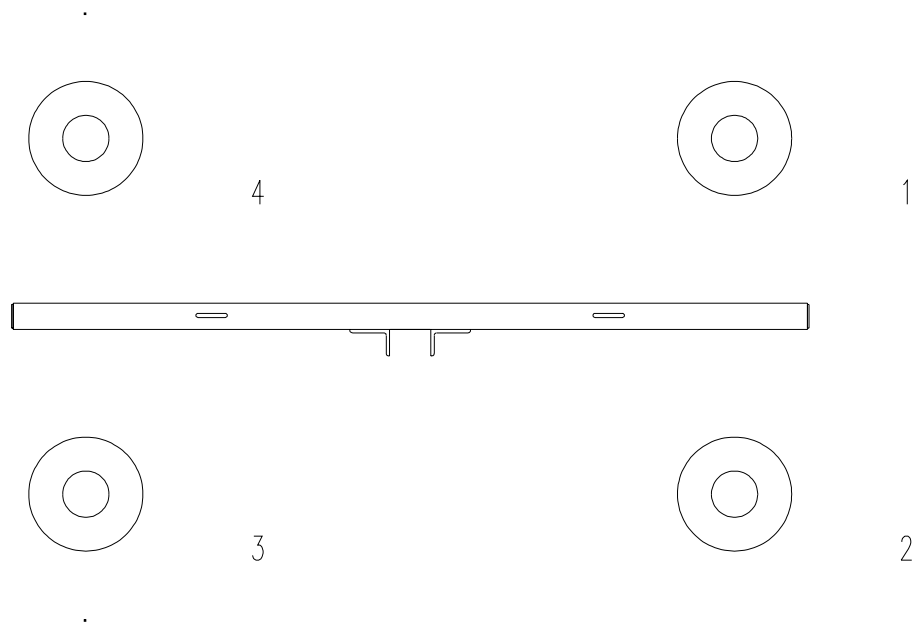

Rear Bearing Inspection Requirements

Leroy-Somer 6 & 8 kw Generators

The rear bearing on all 6 & 8 kw generators should be inspected every two (2) years or 2000 hours, whichever occurs first. The bearing should be replaced at three (3) years or 3000 hours. Careful attention to this inspection procedure will prevent total generator failure resulting from bearing or bearing carrier deterioration.

There are two areas to examine during the inspection. First is the clearance between the bearing outer case and the generator bearing carrier (NDE Bracket). The bearing should fit snugly into the carrier so that it can be rotated only with some resistance. Side to side movement should be less than .010". If the bearing can be moved easily inside the carrier or if there is visible evidence of bearing carrier wear, the housing carrier should be replaced with End Kit #836835 (which includes the carrier, bearing and O-Ring). The second area of concern is the bearing itself. If roughness can be felt when rotating the outer race of the bearing, the bearing needs to be replaced (#836828). The other area to check is to see if the outer race will rock back and forth along the bearing axis. If there is movement in this axis, replace the bearing. If neither of these conditions exist, replace the bearing retaining O-Ring (#836830) and reassemble. Note: These bearings are sealed units and cannot be field serviced.

Follow the same procedure at three (3) years or 3000 hours. At this time replace both the bearing and O-Ring as well as inspecting the bearing carrier.

LEROY-SOMERS LSA37

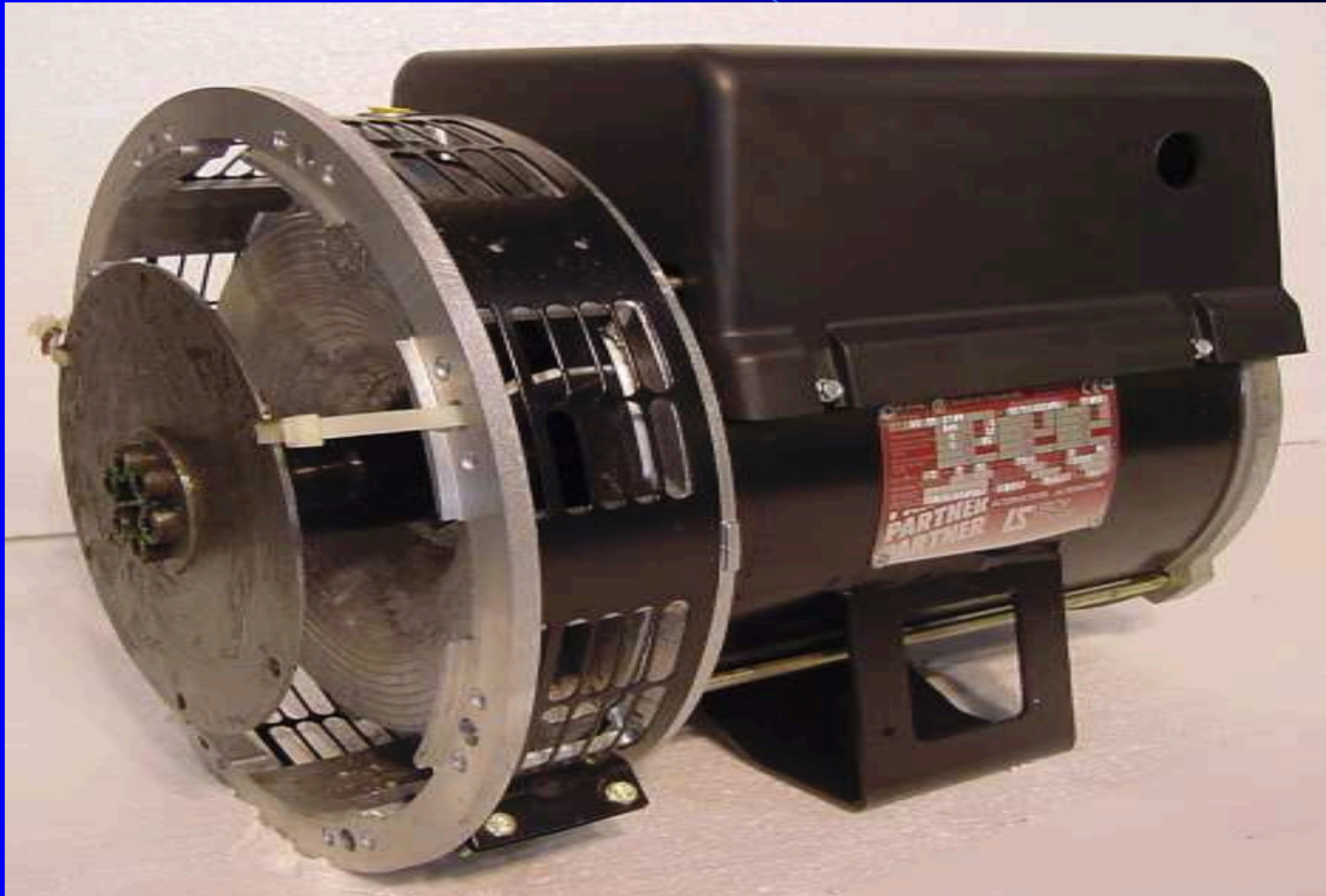

PERFORMANCE

- Brushless
- 4 Pole design
- Self excited with capacitors
- $\pm 5\%$ voltage regulation at constant speed
- Inherent overvoltage protection

PRINCIPLE OF OPERATION

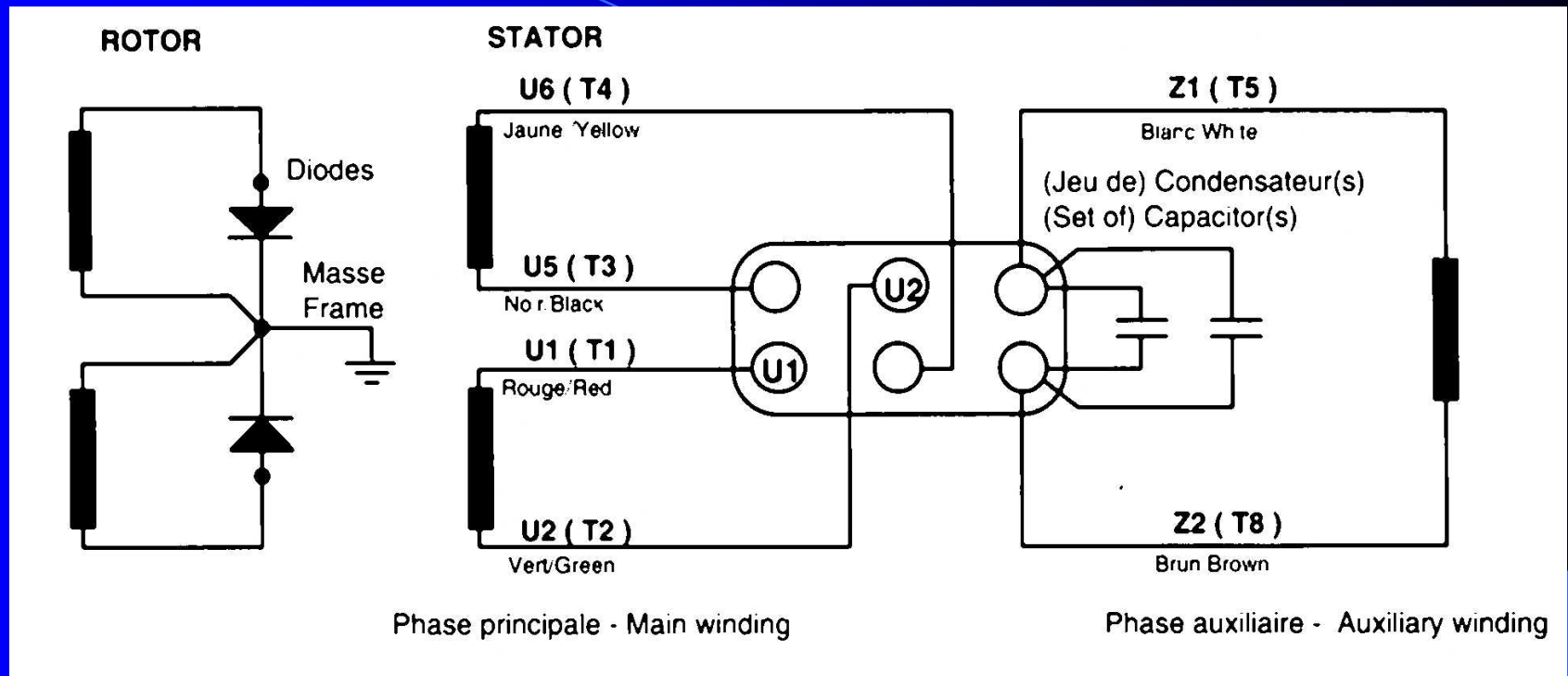

- The capacitor(s) produce the no-load excitation for the unit.
- The rotor magnetic field is produced by the current flowing through the rotating diodes and the main field winding.

WIRING

BRANCHEMENT - CONNECTION DIAGRAM

COUPLAGE PARALLELE - PARALLEL CONNECTION

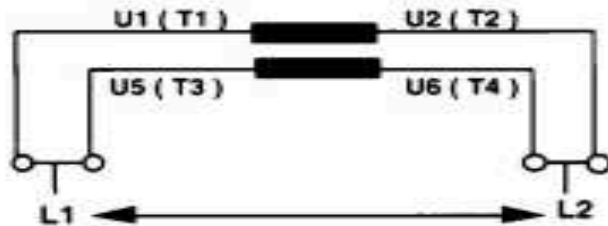

TENSION BASSE - LOWER VOLTAGE

SORTIE - OUTPUT		RELIER - CONNECT	
L1	L2		
U1 . T1 U5 . T3	U6 . T4 U2 . T2	U1 . T1	U5 . T3

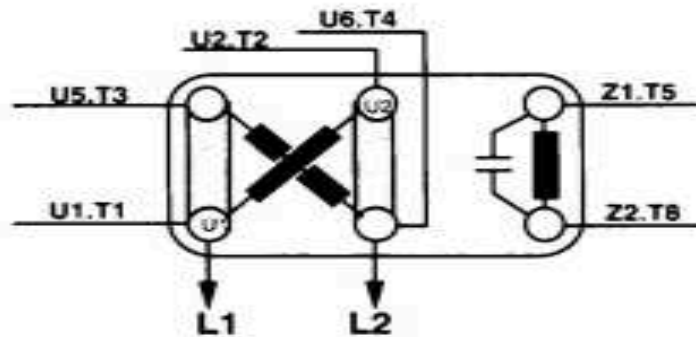

TENSION BASSE - LOWER VOLTAGE

COUPLAGE SERIE - SERIES CONNECTION

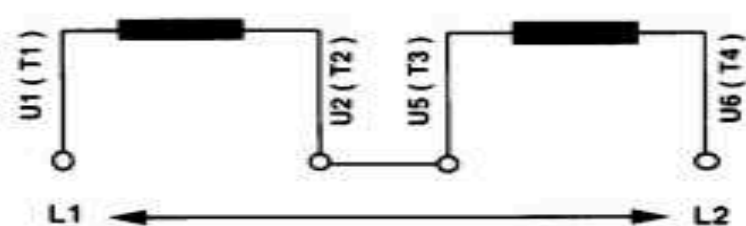

TENSION HAUTE - HIGH VOLTAGE

SORTIE - OUTPUT		RELIER - CONNECT	
L1	L2		
U1.T1	U6.T4	U2.T2	U5.T3

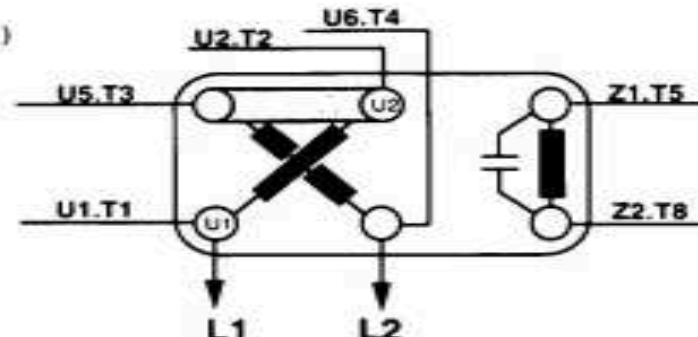

TENSION HAUTE - HIGHER VOLTAGE

AV (D.E.)

AR (N.D.E.)

TERMINAL BOX LAYOUT

Terminal
Block

Capacitor

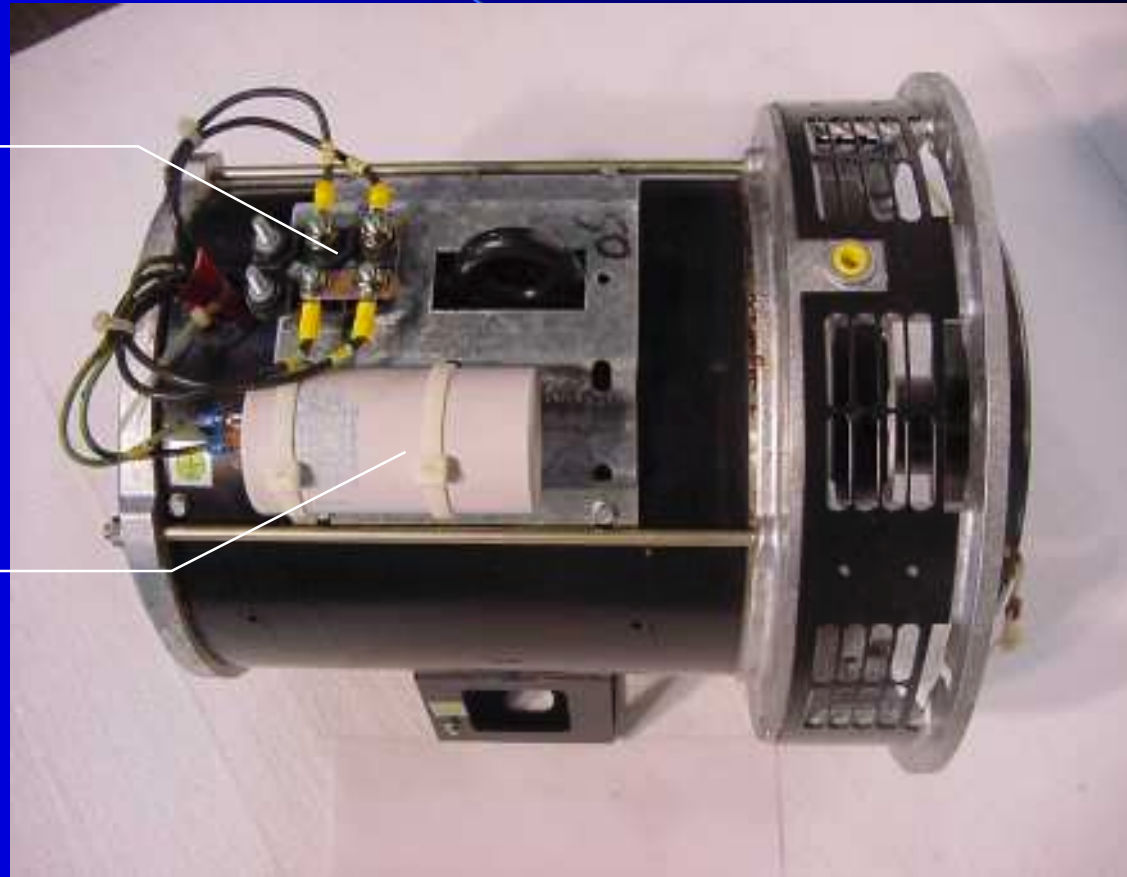

CONSTRUCTION

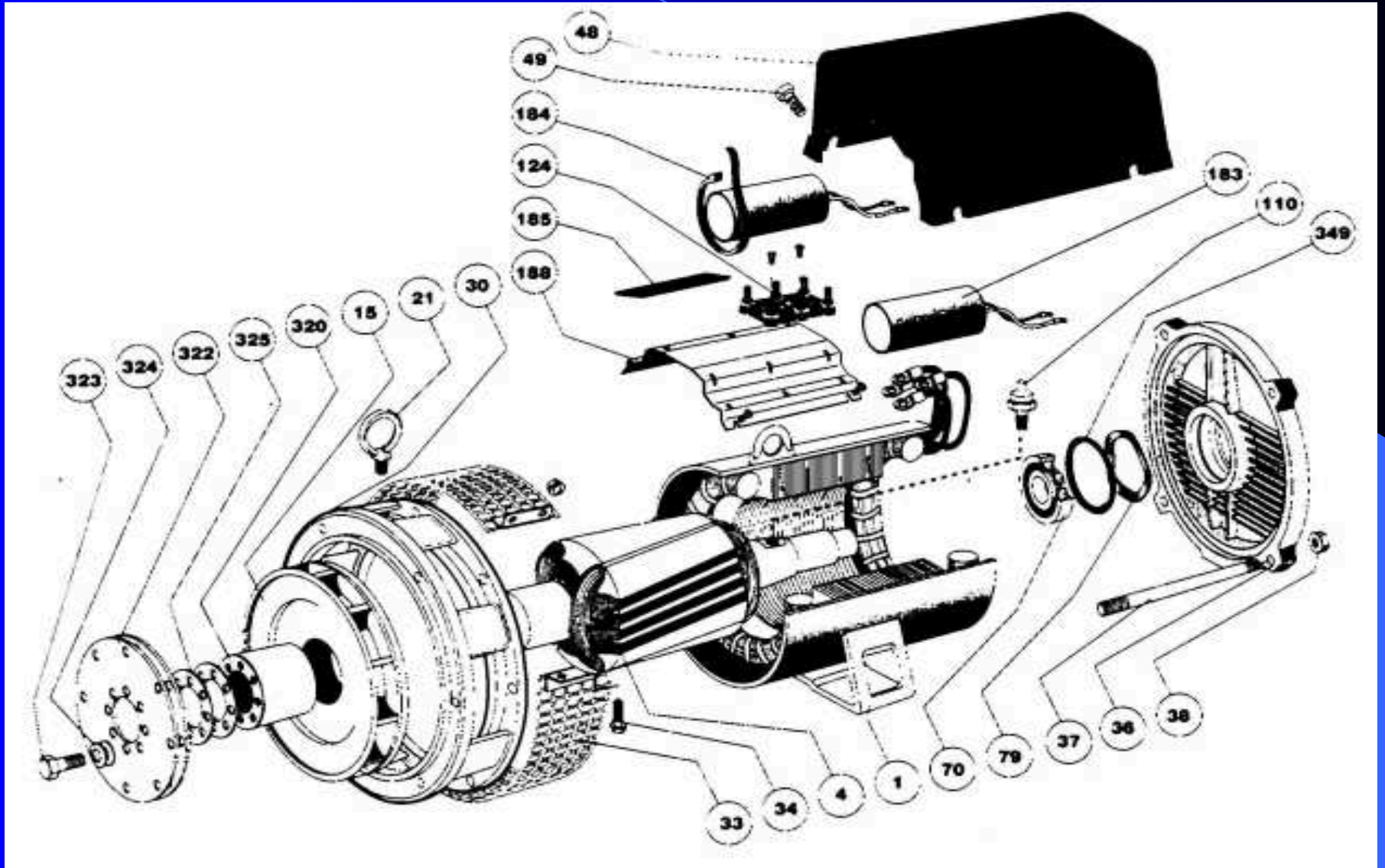

REVOLVING FIELD

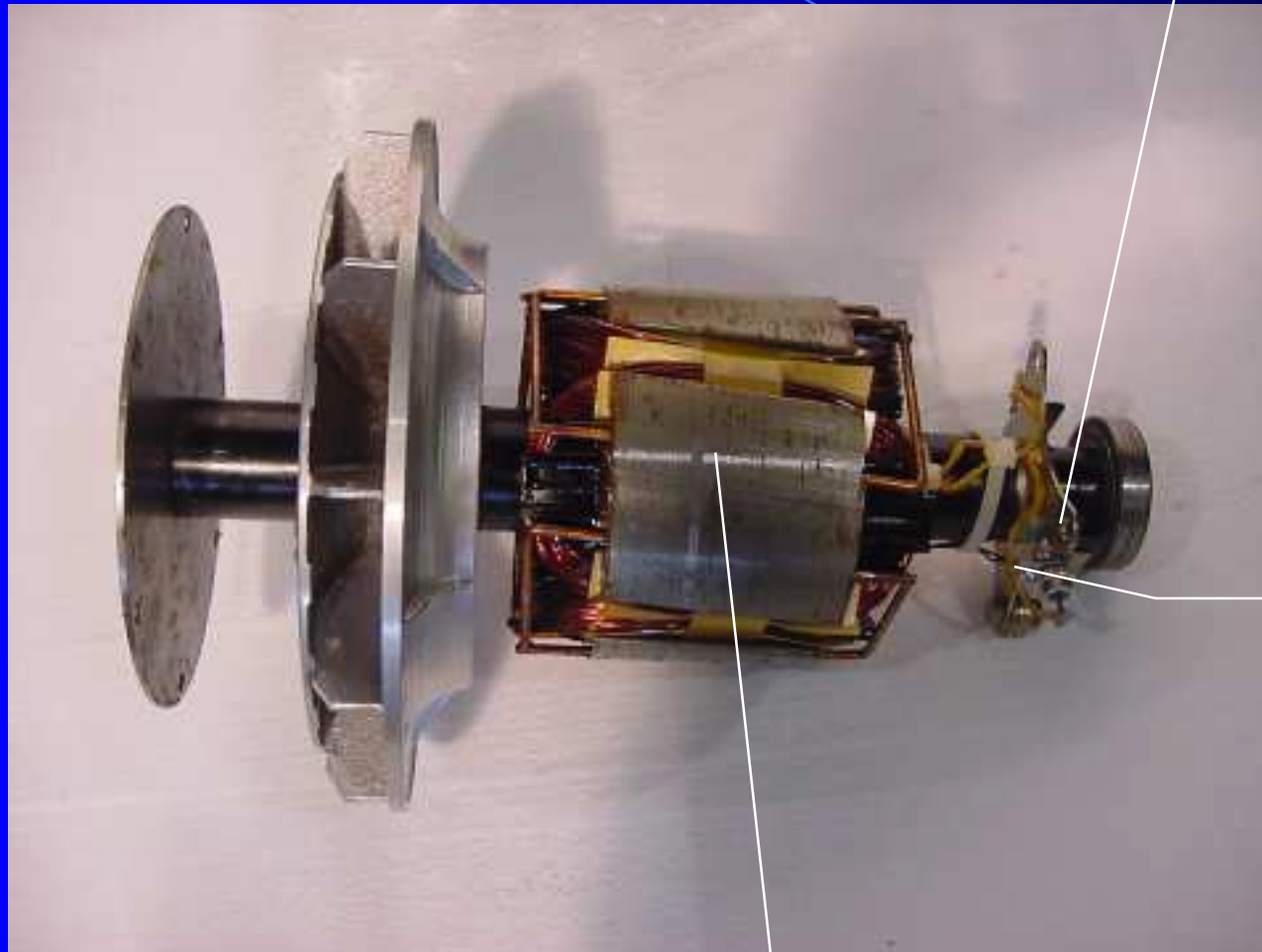

Rotating
Diodes

Balancing
weights

Revolving field

TROUBLESHOOTING TIPS

- No voltage
 - Suspect a capacitor problem (They have a limited life)
- Correct voltage at no load but incorrect under load
 - Suspect a rotating diode problem
- Wrong voltage
 - Suspect an engine RPM problem
- Note: As a general rule, it is more cost effective to replace the unit under warranty if the rotating diodes and the capacitor are good.

NO-NOs

- Do not shut down the units with the lights on.
- Make sure the engine RPM is set properly. The output voltage is proportional with the speed and a voltage too high across the capacitor terminals will shorten its life.
- Make sure the wavy washer is located properly if no end play is found on the set.

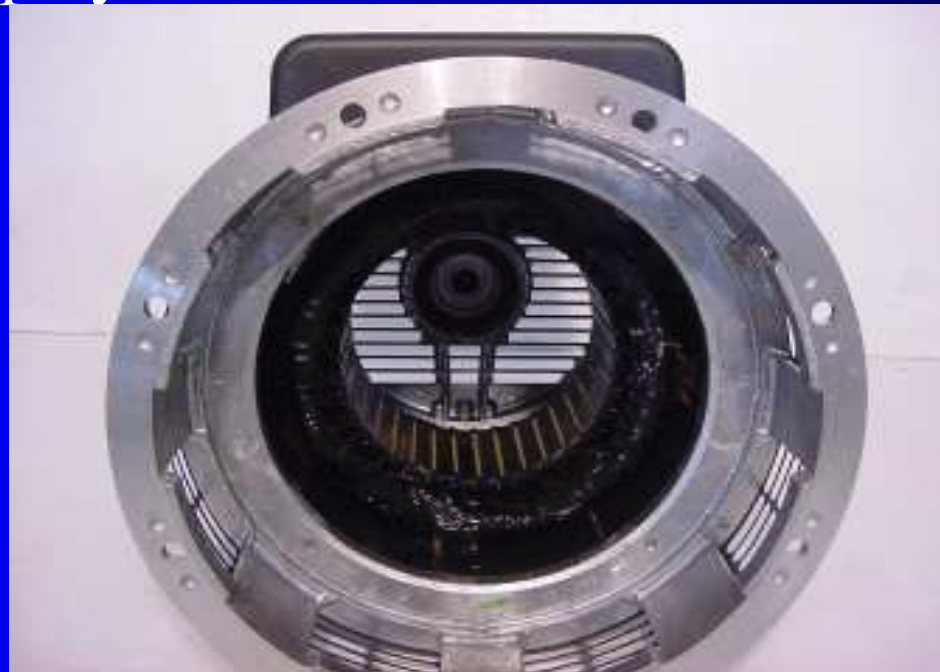

DOCUMENTATION

Technical
Catalog



Data Sheets / Outline
Drawings

Maintenance
Manuals



Parts list / Trouble
Shooting / Assembly

General
Information

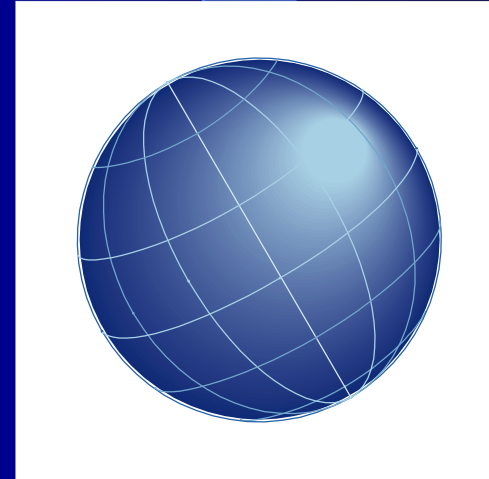

Brochures
Technical Catalog
O&M Manuals
AutoCAD drawings

www.leroy-somer.com

WARRANTY PROCEDURE

The specific language of this warranty will determine TEREX LIGHT CONSTRUCTION's obligation in connection with its product. The information presented below should be used as a general guide for implementation of policy. In the event of a component failure during the warranty period it should be repaired as soon as possible, preferably at an authorized TEREX LIGHT CONSTRUCTION service center. If component is manufactured by a company other than TEREX LIGHT CONSTRUCTION, such as Deutz, Honda, Isuzu, Leroy Somer, Lister Petter, Lombardini, Wisconsin, etc., the applicant should pursue repair and/or reimbursement through that manufacturer, and its dealer/distributor network.

To file a claim with TEREX LIGHT CONSTRUCTION, an **APPLICATION FOR WARRANTY ADJUSTMENT (AWA)** form must be completed in its entirety. Return the completed form within fourteen days of the repair to:

**ATTENTION: WARRANTY
TEREX LIGHT CONSTRUCTION
590 Huey Road
Rock Hill Industrial Park
Rock Hill, SC 29730**

TEREX LIGHT CONSTRUCTION will review the AWA form. Should we desire to inspect the defective parts, we will issue you a return authorization for the defective parts. After inspecting the defective part(s), and it is determined that warranty is due, we will then, at the discretion of TEREX LIGHT CONSTRUCTION, credit the applicants account or send replacement parts.

TEREX LIGHT CONSTRUCTION warranty reimbursements:

1. \$30.00 for each hour's labor we allow toward a repair.
2. Distributors cost of parts not more than the price currently available from TEREX LIGHT CONSTRUCTION.
3. One way surface freight charges on parts returned to TEREX LIGHT CONSTRUCTION.

Many repairs are assigned a predetermined labor schedule which is an average time in which a skilled technician should be able to make a repair. TEREX LIGHT CONSTRUCTION will reimburse not to exceed the predetermined number of hours for a particular repair.

TEREX LIGHT CONSTRUCTION does not reimburse for:

1. Travel, travel time, nor travel labor.
2. Mileage.
3. Excessive diagnostic time.
4. Repairs of defects, malfunctions, or failures resulting from accidents, abuse, misuse, modifications, alterations, improper servicing or lack of performance of required maintenance service.
5. Repairs where defective parts were not shipped back when requested by TEREX LIGHT CONSTRUCTION.
6. Regular maintenance such as parts or labor for oil changes, filter changes or filters.
7. Repairs where defective parts were not received by TEREX LIGHT CONSTRUCTION after TEREX LIGHT CONSTRUCTION issued a return authorization.

TEREX Amida
P.O. Box 3147
Rock Hill, SC 29730

MANUFACTURER'S LIMITED WARRANTY

TEREX Amida warrants to the original purchaser that goods manufactured by it will be free from defects in workmanship and material for a period of one year after invoice from TEREX Amida, provided such goods are installed, operated and maintained in accordance with TEREX Amida's written instructions.

TEREX Amida makes warranty with respect to components and accessories furnished to TEREX Amida, by third parties only to the extent of the original manufacturer's warranty to TEREX Amida. Third party components and accessories are parts such as fixtures, ballasts, engines, hydraulic pumps, fuel pumps, alternators, generators, winches, tires and electrical components. TEREX Amida makes no other warranty, express or implied, and makes no warranty of merchantability or fitness for any particular purpose.

Warranty for repair or replacement parts after warranty period shall extend for **90 days** after invoice date.

Manufacturer's liability and purchaser's sole and exclusive remedy for a failure of goods to perform as warranted for any and all other claims arising out of the purchase and use of the goods, including negligence on the part of TEREX Amida, shall be limited to the repair or replacement of goods returned, transportation prepaid to TEREX Amida. TEREX Amida shall in no event be liable for incidental or consequential damages.

No employee or representative is authorized to change this warranty in any way or grant any other warranty unless such change is made in writing and signed by an officer of TEREX Amida, at its home office.