

HC 110 | Hydraulic Crawler Crane 110 t Lifting Capacity



HC 110

HYDRAULIC CRAWLER CRANE

HC 110
HIGHLIGHTS

- ▶ 110 tons (100 mt) maximum lifting capacity
- ▶ 230 ft (70 m) maximum length of main boom
- ▶ 200 ft + 70 ft (61 m + 21 m) maximum boom and jib
- ▶ Power up / down and freefall on main and auxiliary drums
- ▶ Quiet, comfortable operator's cab with excellent viewing range
- ▶ Hydraulic counterweight removal system simplifies installation and removal
- ▶ Superior transportability – 11 ft (3.35 m) width; 11 ft 3 inch (3.43 m) height
- ▶ 105,000 lb (47 627 kg) transport weight includes sideframes, 3rd drum and boom inner

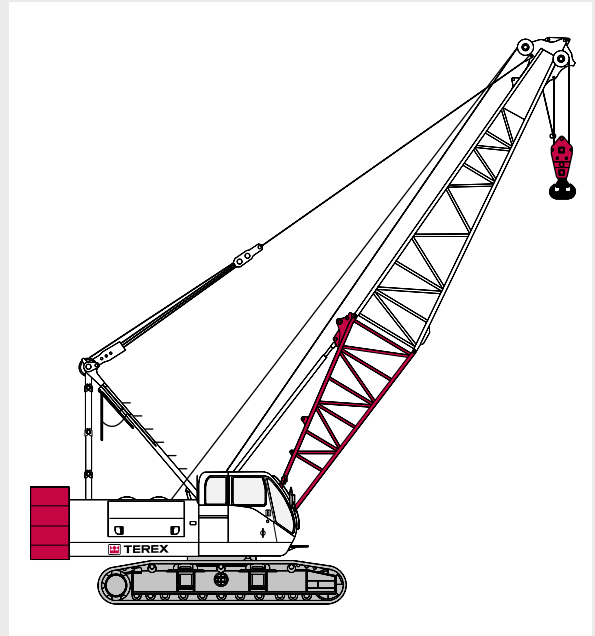

CONTENTS

Page:

Specifications

Dimensions 4

1

Main boom

Range diagram, 59HI Chord Boom 6

With 59HI Offset Tip Boom – 4 Sheave Tip, 52,900 Pounds Upper Counterweight and 23,000 Pounds Sideframe Counterweight –
Sideframes fully extended with Extenders in place 7

2

Jib

Range diagram, 59HI Boom, #9HL Jib 11

With 59HI Offset Tip Boom – 4 Sheave Tip, #9HL Jib and 52,900 Pounds Upper Counterweight and 23,000 Pounds Sideframe Counterweight –
Sideframes fully extended with Extenders in place 12

3

Technical description

Hydraulic Crawler Crane 18

4

Transport example for HC 110

..... 19

5

DIMENSIONS

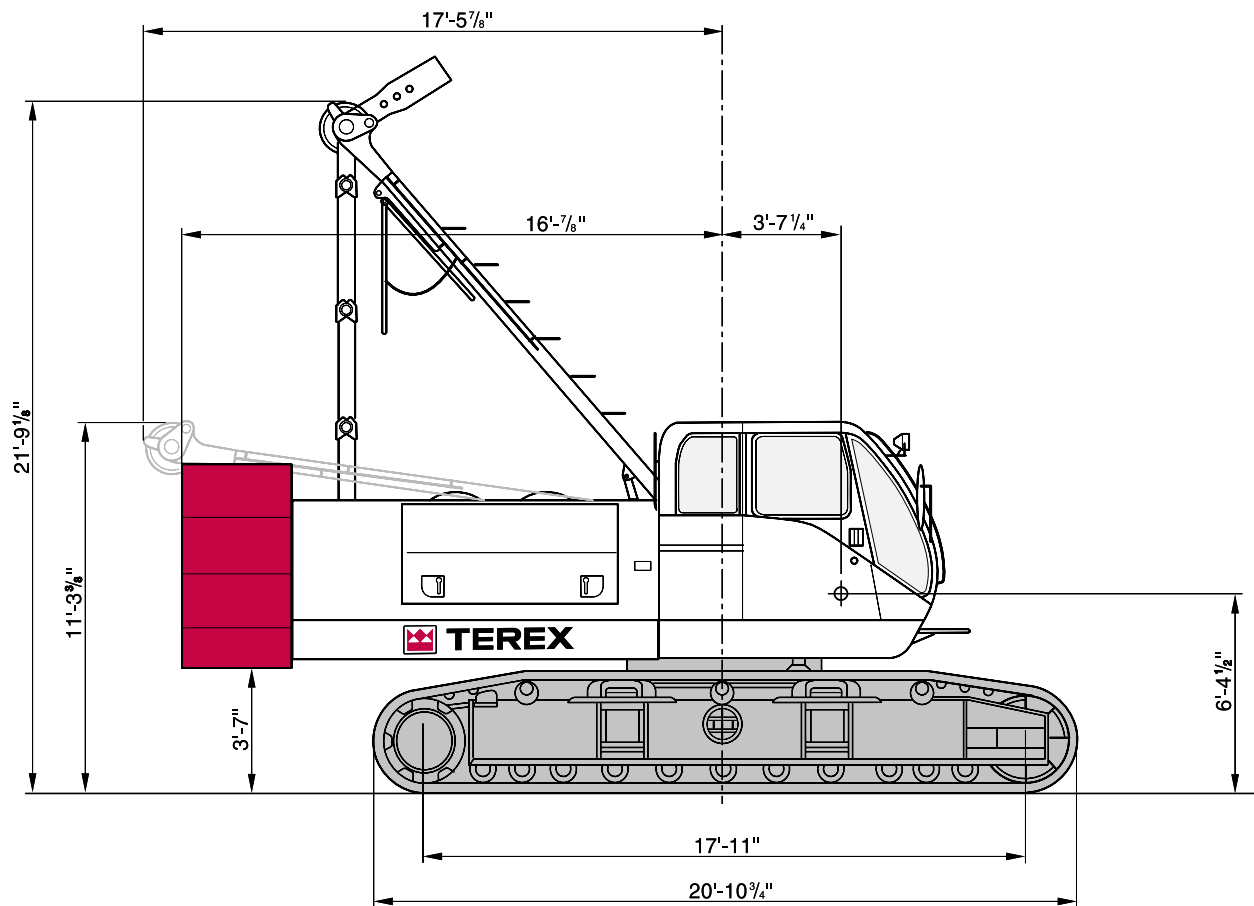

DIMENSIONS

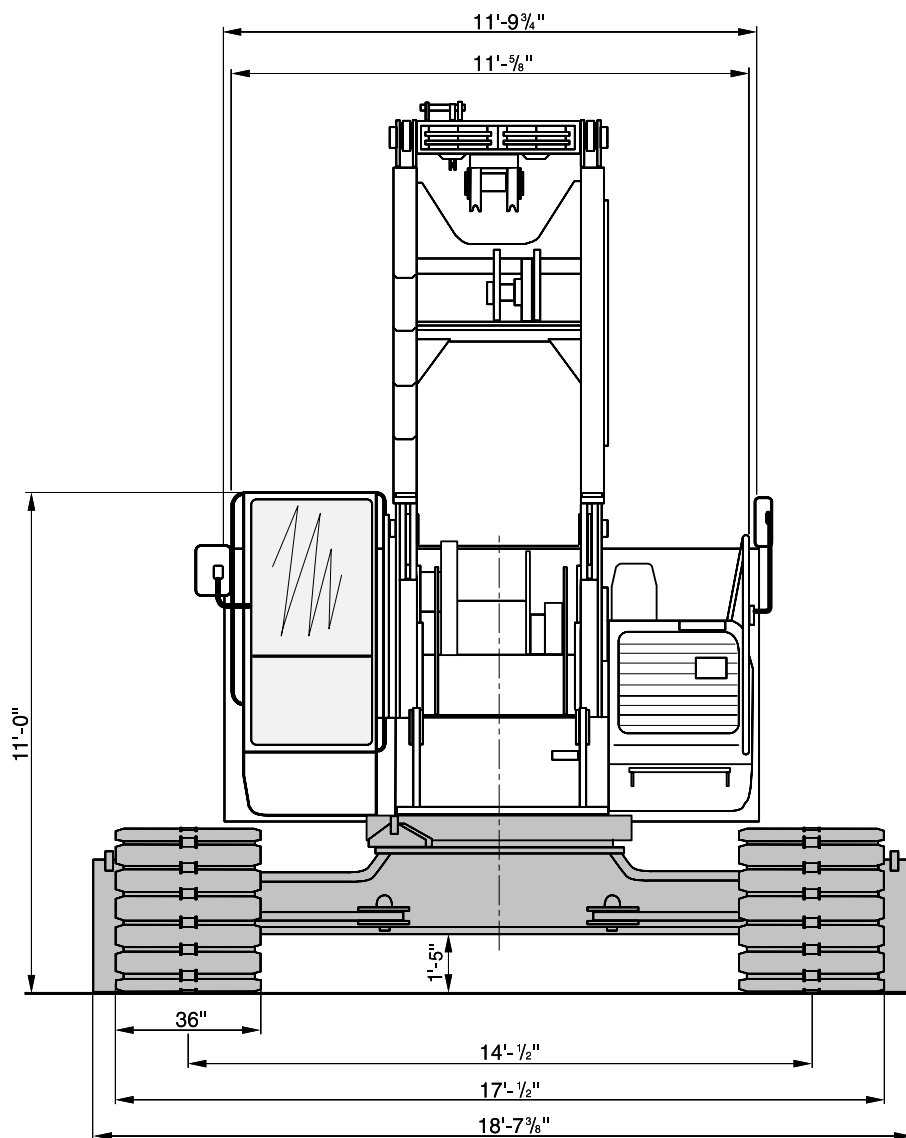

RANGE DIAGRAM, 59HI CHORD BOOM

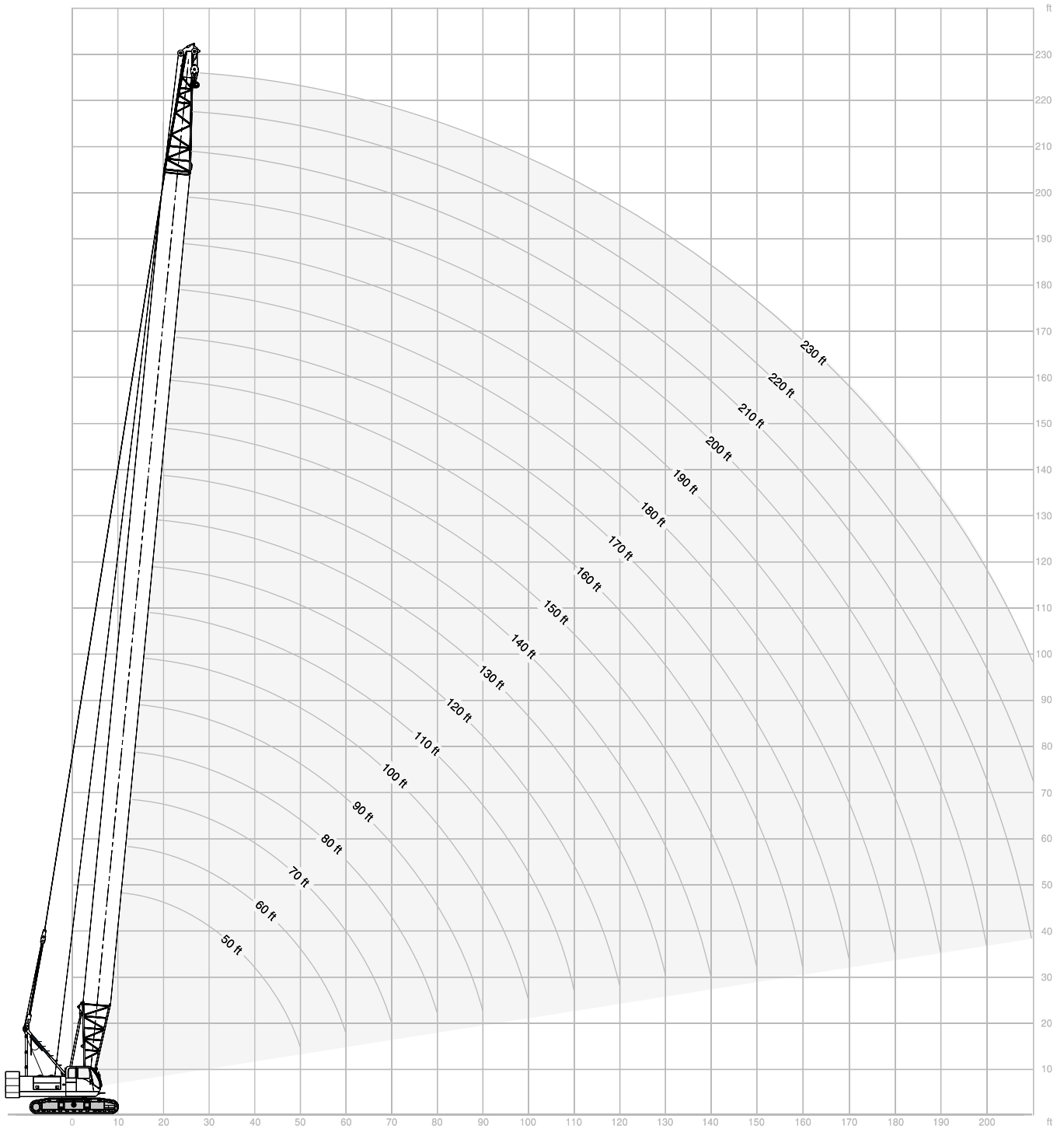

WITH 59HI OFFSET TIP BOOM - 4 SHEAVE TIP

 52,900 lb + 23,000 lb SC

360°

ANSI B 30.5

50' (15.2 m) Boom length			
Radius (Feet)	Boom Angle (Degrees)	Side Frames Extended (Pounds)	From Boom Pt. to Ground (Feet)
13	79.9	220,000*	56
15	77.6	190,080*	55
20	71.6	123,290	54
25	65.4	87,670	52
30	58.9	67,640	49
35	51.9	54,900	46
40	44.1	46,010	41
50	22.7	34,480	26

60' (18.3 m) Boom length			
Radius (Feet)	Boom Angle (Degrees)	Side Frames Extended (Pounds)	From Boom Pt. to Ground (Feet)
14	80.7	203,570*	66
15	79.7	189,950*	65
20	74.8	123,100	64
25	69.7	87,490	63
30	64.5	67,430	61
35	59.1	54,700	58
40	53.3	45,790	54
50	40.0	34,250	45
60	20.6	27,130	27

70' (21.3 m) Boom length			
Radius (Feet)	Boom Angle (Degrees)	Side Frames Extended (Pounds)	From Boom Pt. to Ground (Feet)
16	80.3	177,910*	75
20	77.0	122,950	75
25	72.8	87,320	73
30	68.4	67,250	71
35	63.9	54,530	69
40	59.2	45,620	67
50	49.0	34,050	59
60	36.9	26,960	48
70	19.0	22,070	29

80' (24.4 m) Boom length			
Radius (Feet)	Boom Angle (Degrees)	Side Frames Extended (Pounds)	From Boom Pt. to Ground (Feet)
17	80.8	161,850	85
20	78.7	122,740	85
25	75.0	87,130	84
30	71.2	67,020	82
35	67.4	54,310	80
40	63.4	45,380	78
50	55.0	33,810	72
60	45.7	26,730	64
70	34.4	21,840	52
80	17.7	18,300	31

90' (27.4 m) Boom length			
Radius (Feet)	Boom Angle (Degrees)	Side Frames Extended (Pounds)	From Boom Pt. to Ground (Feet)
19	80.6	133,440	95
20	79.9	122,580	95
25	76.7	86,970	94
30	73.4	66,860	93
35	70.0	54,150	91
40	66.6	45,210	89
50	59.4	33,630	84
60	51.6	26,570	77
70	42.9	21,670	68
80	32.3	18,120	55
90	16.7	15,440	32

100' (30.5 m) Boom length			
Radius (Feet)	Boom Angle (Degrees)	Side Frames Extended (Pounds)	From Boom Pt. to Ground (Feet)
20	80.9	122,380	105
25	78.0	86,760	104
30	75.1	66,630	103
35	72.1	53,930	102
40	69.0	44,980	100
50	62.7	33,380	95
60	56.0	26,340	89
70	48.8	21,430	82
80	40.6	17,880	71
90	30.6	15,190	57
100	15.8	13,090	34

110' (33.5 m) Boom length			
Radius (Feet)	Boom Angle (Degrees)	Side Frames Extended (Pounds)	From Boom Pt. to Ground (Feet)
22	80.7	105,050	115
25	79.1	86,580	114
30	76.5	66,410	113
35	73.8	53,720	112
40	71.0	44,760	110
50	65.4	33,160	106
60	59.5	26,130	101
70	53.2	21,220	94
80	46.4	17,650	86
90	38.6	14,960	75
100	29.1	12,860	60
110	15.1	11,180	35

KEY

 Counterweight

SC Sideframe Counterweight

WITH 59HI OFFSET TIP BOOM - 4 SHEAVE TIP

52,900 lb + 23,000 lb SC

360°

ANSI B 30.5

120' (36.6 m) Boom length

Radius (Feet)	Boom Angle (Degrees)	Side Frames Extended (Pounds)	From Boom Pt. to Ground (Feet)
24	80.5	91,640	125
25	80.1	86,370	125
30	77.6	66,180	124
35	75.2	53,490	122
40	72.7	44,530	121
50	67.6	32,910	117
60	62.3	25,890	113
70	56.7	20,970	107
80	50.8	17,410	99
90	44.3	14,720	90
100	36.9	12,600	78
110	27.9	10,910	62
120	14.4	9,540	36

130' (39.6 m) Boom length

25	80.8	86,180	135
30	78.6	65,990	134
35	76.3	53,300	133
40	74.0	44,340	131
50	69.4	32,700	128
60	64.6	25,690	124
70	59.6	20,770	118
80	54.3	17,210	112
90	48.6	14,510	104
100	42.4	12,400	94
110	35.4	10,700	82
120	26.7	9,310	65
130	13.8	8,160	37

140' (42.7 m) Boom length

27	80.7	76,660	145
30	79.4	65,750	144
35	77.3	53,070	143
40	75.2	44,100	142
50	70.9	32,450	139
60	66.5	25,450	135
70	62.0	20,530	130
80	57.2	16,960	124
90	52.2	14,260	117
100	46.8	12,140	108
110	40.8	10,440	98
120	34.0	9,050	85
130	25.7	7,890	67
140	13.3	6,920	39

150' (45.7 m) Boom length

Radius (Feet)	Boom Angle (Degrees)	Side Frames Extended (Pounds)	From Boom Pt. to Ground (Feet)
28	80.9	72,450	154
30	80.1	65,530	154
35	78.2	52,860	153
40	76.2	43,870	152
50	72.2	32,220	149
60	68.2	25,230	146
70	64.0	20,300	141
80	59.6	16,730	136
90	55.1	14,020	129
100	50.3	11,910	122
110	45.1	10,210	113
120	39.4	8,810	102
130	32.8	7,640	88
140	24.9	6,670	69
150	12.8	5,840	40

160' (48.8 m) Boom length

30	80.7	65,300	164
35	78.9	52,640	163
40	77.1	43,640	162
50	73.4	31,960	160
60	69.6	24,990	156
70	65.7	20,060	152
80	61.7	16,480	147
90	57.6	13,770	141
100	53.2	11,650	134
110	48.6	9,950	126
120	43.6	8,550	117
130	38.1	7,380	105
140	31.8	6,400	91
150	24.0	5,550	72
160	12.4	4,850	41

170' (51.8 m) Boom length

31	80.9	62,050	174
35	79.6	52,430	174
40	77.9	43,420	173
50	74.4	31,740	170
60	70.8	24,780	167
70	67.2	19,850	163
80	63.5	16,270	159
90	59.7	13,560	153
100	55.7	11,430	147
110	51.5	9,730	139
120	47.0	8,320	131
130	42.2	7,150	121
140	36.9	6,160	108
150	30.8	5,320	93
160	23.3	4,600	74
170	12.1	3,990	42

WITH 59HI OFFSET TIP BOOM - 4 SHEAVE TIP

52,900 lb + 23,000 lb SC

360°

ANSI B 30.5

180' (54.9 m) Boom length			
Radius (Feet)	Boom Angle (Degrees)	Side Frames Extended (Pounds)	From Boom Pt. to Ground (Feet)
33	80.8	56,790	184
35	80.2	52,200	184
40	78.6	43,200	183
50	75.3	31,490	180
60	71.9	24,560	178
70	68.6	19,600	174
80	65.1	16,020	170
90	61.5	13,310	165
100	57.8	11,180	159
110	54.0	9,470	152
120	49.9	8,070	144
130	45.6	6,890	135
140	41.0	5,900	124
150	35.8	5,060	112
160	29.9	4,330	96
170	22.6	3,690	76
180	11.7	3,150	43

210' (64.0 m) Boom length			
Radius (Feet)	Boom Angle (Degrees)	Side Frames Extended (Pounds)	From Boom Pt. to Ground (Feet)
38	80.8	41,260*	214
40	80.2	40,530*	213
50	77.4	30,780	211
60	74.6	23,870	209
70	71.7	18,910	206
80	68.8	15,320	202
90	65.9	12,600	198
100	62.9	10,470	193
110	59.7	8,750	188
120	56.5	7,340	182
130	53.2	6,160	174
140	49.7	5,170	166
150	46.0	4,310	157
160	42.0	3,570	147
170	37.8	2,920	135
180	33.0	2,360	121
190	27.6	1,860	104

190' (57.9 m) Boom length			
Radius (Feet)	Boom Angle (Degrees)	Side Frames Extended (Pounds)	From Boom Pt. to Ground (Feet)
34	81.0	52,440*	194
35	80.7	51,980	194
40	79.2	42,970	193
50	76.1	31,260	191
60	72.9	24,330	188
70	69.7	19,370	185
80	66.5	15,790	181
90	63.2	13,070	176
100	59.7	10,940	170
110	56.2	9,230	164
120	52.4	7,820	157
130	48.5	6,650	149
140	44.3	5,660	139
150	39.8	4,810	128
160	34.8	4,070	115
170	29.1	3,430	99
180	22.0	2,880	78
190	11.4	2,410	44

220' (67.1 m) Boom length			
Radius (Feet)	Boom Angle (Degrees)	Side Frames Extended (Pounds)	From Boom Pt. to Ground (Feet)
39	80.9	36,220*	224
40	80.7	35,920*	223
50	78.0	30,530	222
60	75.3	23,640	219
70	72.6	18,670	216
80	69.8	15,080	213
90	67.1	12,350	209
100	64.2	10,220	204
110	61.3	8,490	199
120	58.2	7,090	193
130	55.1	5,900	187
140	51.9	4,900	179
150	48.5	4,050	171
160	44.9	3,300	162
170	41.0	2,650	151
180	36.9	2,090	138
190	32.3	1,590	124

200' (61.0 m) Boom length			
Radius (Feet)	Boom Angle (Degrees)	Side Frames Extended (Pounds)	From Boom Pt. to Ground (Feet)
36	80.9	46,580*	204
40	79.7	42,730	203
50	76.8	31,010	201
60	73.8	24,090	198
70	70.8	19,130	195
80	67.7	15,540	191
90	64.6	12,820	187
100	61.4	10,690	182
110	58.0	8,980	176
120	54.6	7,570	169
130	51.0	6,390	162
140	47.2	5,390	153
150	43.1	4,540	143
160	38.8	3,800	132
170	33.9	3,170	118
180	28.3	2,610	101
190	21.5	2,120	80
200	11.1	1,700	45

230' (70.1 m) Boom length			
Radius (Feet)	Boom Angle (Degrees)	Side Frames Extended (Pounds)	From Boom Pt. to Ground (Feet)
41	80.8	31,600*	233
50	78.5	27,960*	232
60	76.0	23,410	230
70	73.4	18,440	227
80	70.8	14,840	224
90	68.1	12,110	220
100	65.4	9,970	215
110	62.6	8,250	211
120	59.8	6,830	205
130	56.8	5,660	199
140	53.8	4,660	192
150	50.6	3,800	184
160	47.3	3,060	175
170	43.8	2,410	166
180	40.1	1,840	154

NOTES TO LIFTING CAPACITY

Warning

This rating chart is invalid if the crane has been modified or altered by use of other than GENUINE AMERICAN PARTS as such modifications or alterations may affect its capacity or safe operation. See American Crane Corporation Service Bulletin #259.

Ratings in this chart are in POUNDS and do not exceed the percentage of tipping specified for this crane by ANSI B30.5. All ratings require that the crane be standing level on a firm uniformly supporting surface.

Do not lift loads in excess of those shown on this chart. Lifting loads in excess of those shown or operation not in accordance with good operating practice, including limitations shown on page 3499 of Operator's Manual, can cause tipping, structural damage or catastrophic failure.

Asterisk (*) areas on this chart indicate ratings that are limited by strength of material or factors other than stability (tipping).

„RADIUS IN FEET“ is the horizontal distance at ground level from the crane centerline of rotation to a vertical line through the center of gravity of the suspended load. When using the main boom fall with jib in place, the main fall ratings must be reduced by the jib effective weight shown on the jib rating chart plus twice the weight of all suspended blocks, slings, rope, etc., at the jib fall. See Appendix A.

When using the main boom fall with boom tip extension in place, the main fall ratings must be reduced by the weight of the boom tip extension plus twice the weight of all suspended blocks, slings, rope, etc., at the boom tip extension fall. See Appendix A.

Blocks, slings, buckets and other load carrying devices are considered part of the load. The weight of standard hoisting ropes for the rating at a given radius has been calculated as part of the boom point load and need not be considered in determining net allowable loads. See Appendix A.

This chart was developed exclusively for use with a boom only. Under no circumstances are these ratings to be interpreted for use with a jib.

Ratings shown on this chart make no allowance for such factors as out of plumb loads, wind, poor soil conditions, improper inflation of rubber tires and dynamic effects due to excessive operating speeds. The user (operator) must exercise judgment to make allowance for these conditions. See page 3499 of Operator's Manual for detailed information.

No account is taken of the wind force on the load. The user must consider this effect, which can be substantial for loads with large surface areas. In any wind it is strongly recommended that taglines be used to control the load.

BOOM HOIST LINE – 12 parts of 3/4 inch diameter IPS wire rope with a minimum breaking strength of 51,200 pounds.

PENDANT SUSPENSION LINE – 2 parts of 1-3/8 inch diameter EEIPS wire rope with a minimum breaking strength of 211,000 pounds.

MAIN LOAD LINE – 1.000 inch diameter EIPS wire rope with a minimum breaking strength of 103,400 pounds or 0.875 inch diameter EIPS wire rope with a minimum breaking strength of 79,600 pounds.

SIDEFAME POSITION DEFINITIONS

These ratings are valid for the sideframe positions as indicated below. Refer to the HC 110 Operator's Manual for additional information.

ERECTION

Erection „OVER-THE-END BLOCKED“ is with the boom over the idler end with idler tumblers blocked (See HC 110 Operator's Manual for blocking instructions). Erection „OVER-THE-SIDE“ is with the boom 90° to the sideframes. Blocks, slings and other load carrying devices must be on the ground during erection.

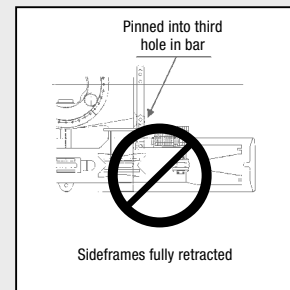
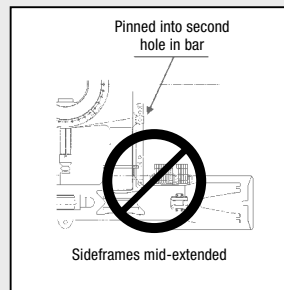
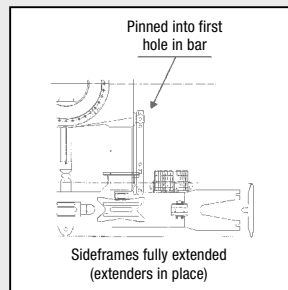

59HI OFFSET TIP BOOM MAXIMUM BOOM & JIB SELF-ERECTION DATA				
JIB	OVER-THE-END BLOCKED		OVER-THE-SIDE	
			SIDEFRAMES FULLY-EXTENDED (WITH EXTENDERS IN PLACE)	
	BOOM LENGTH (FEET)	JIB LENGTH (FEET)	BOOM LENGTH (FEET)	JIB LENGTH (FEET)
9HL	230	0	210	0
	220	0	200	0
	210	40	190	40
	200	70	180	70

LOAD HOISTING INFORMATION - 1.00" diameter EIPS wire rope			
MAXIMUM LIFTING CAPACITY - LBS.	MINIMUM PARTS OF LINE	MAXIMUM HOISTING DISTANCE - FEET	
		MAIN HOIST	AUX HOIST
220,000	8	130	
206,800	7	148	
177,250	6	173	
147,700	5	208	
118,150	4	260	NOT APPLICABLE
88,600	3	346	
59,050	2	520	
29,500	1	1040	

LOAD HOISTING INFORMATION - 7/8" diameter EIPS wire rope			
MAXIMUM LIFTING CAPACITY - LBS.	MINIMUM PARTS OF LINE	MAXIMUM HOISTING DISTANCE - FEET	
		MAIN HOIST	AUX HOIST
181,900	8		78
159,200	7		89
136,450	6		104
113,700	5		125
90,950	4	NOT APPLICABLE	156
68,200	3		208
45,450	2		313
22,700	1		626

BOOM COMPOSITION CHART - 59HI OFFSET TIP					
BOOM LENGTH (FEET)	BOOM SECTIONS				
	25' 59HI INNER	10' 59H CENTER	20' 59H CENTER	40' 59H CENTER	25' 59HI OUTER
50	1	0	0	0	1
60	1	1	0	0	1
70	1	0	1	0	1
80	1	1	1	0	1
90	1	0	0	1	1
100	1	1	0	1	1
110	1	0	1	1	1
120	1	1	1	1	1
130	1	0	0	2	1
140	1	1	0	2	1
150	1	0	1	2	1
160	1	1	1	2	1
170	1	0	0	3	1
180	1	1	0	3	1
190	1	0	1	3	1
200	1	1	1	3	1
210	1	0	0	4	1
220	1	1	0	4	1
230	1	0	1	4	1

CRAWLER CRANE
HC 110

RANGE DIAGRAM, 59HI BOOM, #9HL JIB

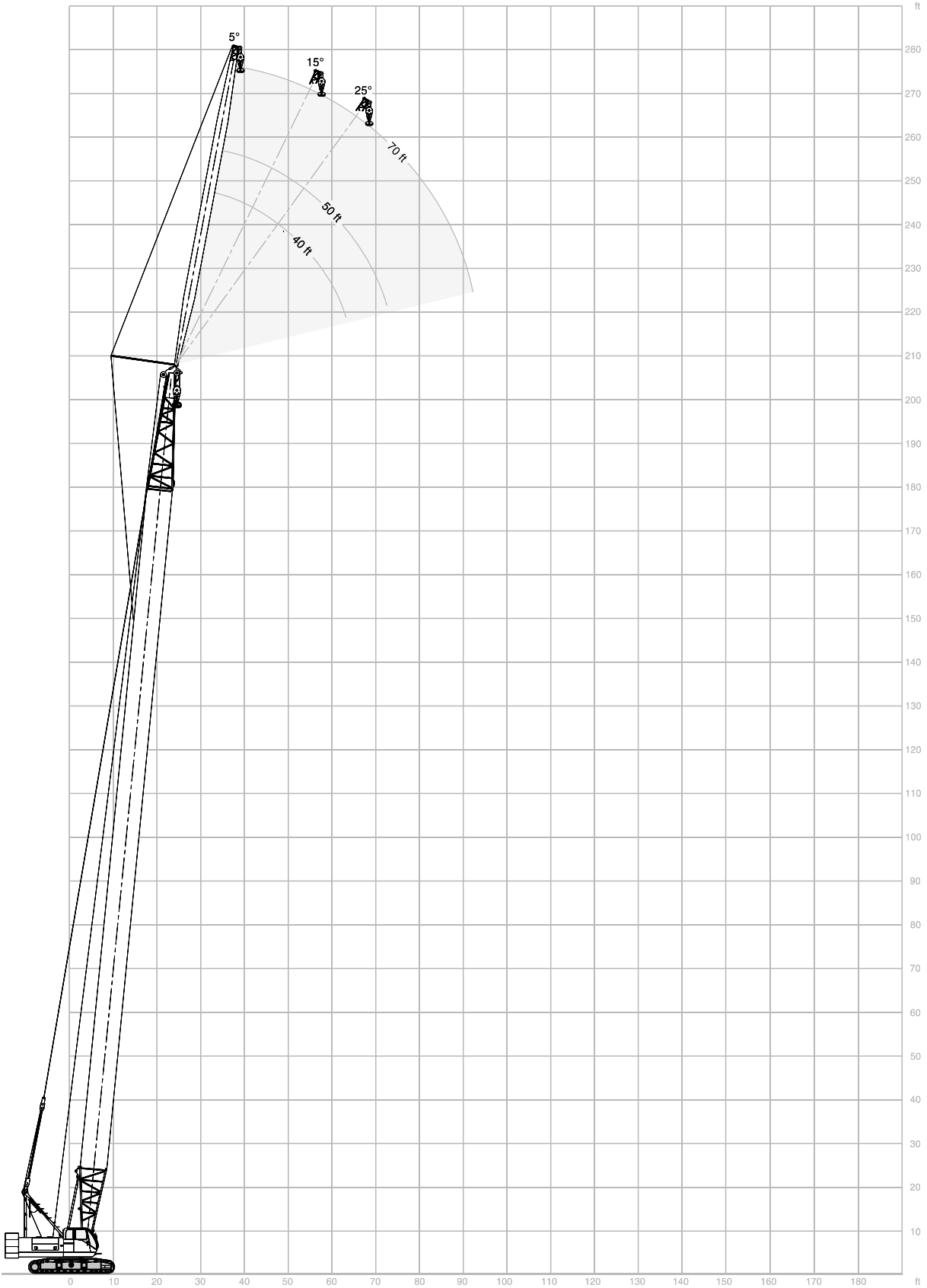



WITH 59HI OFFSET TIP BOOM - 4 SHEAVE TIP, #9HL JIB

52,900 lb + 23,000 lb SC

360°

ANSI B 30.5

40' (12.2 m) Jib length

Boom length	Jib Radius (Feet)	5.0 Deg offset		15.0 Deg offset		25.0 Deg offset	
		Boom Angle	Rating (Pounds)	Boom Angle	Rating (Pounds)	Boom Angle	Rating (Pounds)
	30	80.7	22,540*	-	-	-	-
	35	78.6	22,540*	-	-	-	-
	40	76.6	22,420*	79.3	21,270*	-	-
	50	72.3	21,780*	75.0	20,710*	77.5	19,820*
100' (30.5 m)	60	68.0	21,120*	70.7	20,150*	73.1	19,470*
	70	63.5	20,520*	66.1	19,710*	68.5	18,290*
	80	58.9	18,220	61.4	18,220	63.7	16,950*
	90	53.9	15,520	56.5	15,520	58.7	15,520
	100	48.7	13,390	51.1	13,390	53.2	13,400

	31	80.9	22,530*	-	-	-	-
	35	79.4	22,530*	-	-	-	-
	40	77.5	22,530*	80.0	21,320*	-	-
	50	73.5	21,900*	76.0	20,820*	78.4	19,920*
110' (33.5 m)	60	69.5	21,300*	72.0	20,320*	74.3	19,550*
	70	65.4	20,770*	67.9	19,840*	70.1	18,820*
	80	61.1	17,960	63.6	17,970	65.7	17,500*
	90	56.7	15,250	59.1	15,250	61.2	15,260
	100	52.0	13,130	54.3	13,130	56.3	13,140
	110	46.9	11,430	49.2	11,430	51.1	11,430

	33	80.8	22,520*	-	-	-	-
	35	80.1	22,520*	-	-	-	-
	40	78.2	22,520*	80.6	21,470*	-	-
	50	74.6	22,040*	76.9	20,920*	79.2	19,950*
120' (36.6 m)	60	70.9	21,450*	73.2	20,470*	75.4	19,620*
	70	67.0	20,970*	69.3	20,010*	71.5	19,310*
	80	63.1	17,680	65.4	17,680	67.4	17,680
	90	59.0	14,980	61.3	14,980	63.2	14,980
	100	54.7	12,850	56.9	12,850	58.8	12,850
	110	50.2	11,140	52.3	11,140	54.2	11,140
	120	45.3	9,740	47.4	9,740	49.1	9,750

	34	81.0	22,500*	-	-	-	-
	35	80.6	22,500*	-	-	-	-
	40	78.9	22,500*	-	-	-	-
	50	75.5	22,190*	77.7	20,980*	79.8	20,010*
130' (39.6 m)	60	72.0	21,610*	74.2	20,560*	76.3	19,630*
	70	68.5	21,010	70.6	20,130*	72.6	19,330*
	80	64.8	17,440	66.9	17,440	68.9	17,450
	90	61.0	14,730	63.1	14,730	65.0	14,730
	100	57.1	12,610	59.2	12,610	61.0	12,610
	110	52.9	10,900	55.0	10,900	56.8	10,900
	120	48.6	9,490	50.6	9,490	52.3	9,500
	130	43.9	8,320	45.8	8,330	47.4	8,330

	36	80.8	22,490*	-	-	-	-
	40	79.6	22,490*	-	-	-	-
	50	76.3	22,330*	78.4	21,060*	80.4	20,060*
	60	73.0	21,760*	75.1	20,620*	77.1	19,710*
140' (42.7 m)	70	69.7	20,750	71.8	20,210*	73.7	19,420*
	80	66.3	17,170	68.3	17,170	70.2	17,170
	90	62.8	14,450	64.8	14,450	66.6	14,460
	100	59.1	12,330	61.1	12,330	62.9	12,340
	110	55.3	10,620	57.3	10,620	59.0	10,630
	120	51.3	9,210	53.3	9,210	54.9	9,220
	130	47.1	8,040	49.0	8,050	50.5	8,050
	140	42.6	7,050	44.4	7,050	45.8	7,060

Boom length	Jib Radius (Feet)	5.0 Deg offset		15.0 Deg offset		25.0 Deg offset	
		Boom Angle	Rating (Pounds)	Boom Angle	Rating (Pounds)	Boom Angle	Rating (Pounds)
	38	80.7	22,470*	-	-	-	-
	40	80.1	22,470*	-	-	-	-
	50	77.1	22,470*	79.1	21,150*	80.9	20,080*
	60	74.0	21,980*	75.9	20,700*	77.8	19,800*
	70	70.8	20,490	72.8	20,350*	74.6	19,510*
	80	67.6	16,920	69.5	16,920	71.3	16,920
150' (45.7 m)	90	64.3	14,200	66.2	14,200	67.9	14,200
	100	60.9	12,070	62.8	12,080	64.5	12,080
	110	57.4	10,360	59.3	10,360	60.9	10,370
	120	53.7	8,950	55.6	8,960	57.1	8,960
	130	49.9	7,770	51.7	7,780	53.2	7,780
	140	45.8	6,780	47.5	6,780	49.0	6,780
	150	41.4	5,930	43.1	5,940	44.4	5,940

	39	80.9	22,460*	-	-	-	-
	40	80.6	22,460*	-	-	-	-
	50	77.7	22,460*	79.6	21,240*	-	-
	60	74.8	22,100*	76.7	20,780*	78.4	19,810*
	70	71.8	20,230	73.7	20,230	75.4	19,510*
	80	68.8	16,640	70.6	16,650	72.3	16,650
160' (48.8 m)	90	65.7	13,930	67.5	13,930	69.2	13,940
	100	62.5	11,800	64.3	11,800	65.9	11,800
	110	59.2	10,090	61.0	10,090	62.6	10,090
	120	55.8	8,680	57.6	8,680	59.1	8,680
	130	52.3	7,500	54.0	7,500	55.5	7,500
	140	48.5	6,510	50.2	6,510	51.6	6,510
	150	44.5	5,650	46.2	5,650	47.5	5,660
	160	40.3	4,910	41.9	4,910	43.1	4,920

	41	80.8	22,450*	-	-	-	-
	50	78.3	22,450*	80.1	21,260*	-	-
	60	75.5	22,170*	77.3	20,850*	79.0	19,890*
	70	72.7	19,990	74.5	20,000	76.1	19,610*
	80	69.8	16,410	71.6	16,410	73.2	16,410
	90	66.9	13,690	68.6	13,690	70.2	13,690
170' (51.8 m)	100	63.9	11,560	65.6	11,560	67.2	11,570
	110	60.8	9,840	62.5	9,840	64.0	9,840
	120	57.6	8,440	59.3	8,440	60.8	8,440
	130	54.3	7,260	56.0	7,260	57.4	7,260
	140	50.9	6,260	52.5	6,260	53.9	6,270
	150	47.3	5,400	48.9	5,400	50.2	5,410
	160	43.4	4,670	45.0	4,670	46.2	4,670
	170	39.2	4,010	40.8	4,020	41.9	4,020

	42	80.9	22,430*	-	-	-	-
	50	78.8	22,430*	80.6	21,360*	-	-
	60	76.2	22,300*	77.9	20,920*	79.5	19,910*
	70	73.5	19,730	75.2	19,730	76.8	19,610*
	80	70.8	16,140	72.5	16,150	74.0	16,150
	90	68.0	13,420	69.7	13,420	71.2	13,420
180' (54.9 m)	100	65.2	11,290	66.8	11,290	68.3	11,290
	110	62.3	9,570	63.9	9,580	65.4	9,580
	120	59.3	8,160	60.9	8,160	62.3	8,170
	130	56.2	6,980	57.8	6,980	59.2	6,990
	140	53.0	5,990	54.6	5,990	55.9	6,000
	150	49.6	5,130	51.2	5,140	52.5	5,140
	160	46.1	4,390	47.6	4,390	48.9	4,390
	170	42.3	3,740	43.8	3,740	45.0	3,750
	180	38.3	3,170	39.7	3,170	40.8	3,180

WITH 59HI OFFSET TIP BOOM - 4 SHEAVE TIP, #9HL JIB

52,900 lb + 23,000 lb SC

360°

ANSI B 30.5

40' (12.2 m) Jib length

Boom length	Jib Radius (Feet)	5.0 Deg offset		15.0 Deg offset		25.0 Deg offset	
		Boom Angle	Rating (Pounds)	Boom Angle	Rating (Pounds)	Boom Angle	Rating (Pounds)
	44	80.8	21,930*	-	-	-	-
	50	79.3	21,270*	81.0	19,700*	-	-
	60	76.8	20,090*	78.4	18,900*	80.0	17,680*
	70	74.2	18,990*	75.9	18,040*	77.4	17,090*
	80	71.6	15,890	73.3	15,890	74.7	15,890
	90	69.0	13,170	70.6	13,180	72.1	13,180
190' (57.9 m)	100	66.3	11,030	67.9	11,030	69.3	11,040
	110	63.6	9,320	65.1	9,320	66.5	9,320
	120	60.7	7,910	62.3	7,910	63.7	7,910
	130	57.8	6,720	59.4	6,730	60.7	6,730
	140	54.8	5,720	56.4	5,730	57.7	5,730
	150	51.7	4,870	53.2	4,880	54.5	4,880
	160	48.5	4,130	50.0	4,130	51.2	4,130
	170	45.0	3,480	46.5	3,480	47.6	3,490
	180	41.4	2,910	42.8	2,910	43.9	2,910
	190	37.4	2,400	38.8	2,410	39.7	2,410

Boom length	Jib Radius (Feet)	5.0 Deg offset		15.0 Deg offset		25.0 Deg offset	
		Boom Angle	Rating (Pounds)	Boom Angle	Rating (Pounds)	Boom Angle	Rating (Pounds)
	47	80.9	16,340*	-	-	-	-
	50	80.2	16,030*	-	-	-	-
	60	77.9	14,900*	79.4	14,170*	80.8	13,290*
	70	75.5	13,870*	77.0	13,330*	78.4	12,720*
	80	73.1	12,940*	74.6	12,510*	76.0	12,040*
	90	70.7	12,040*	72.2	11,700*	73.6	11,330*
210' (64.0 m)	100	68.3	10,530	69.8	10,530	71.1	10,530
	110	65.8	8,810	67.3	8,810	68.6	8,810
	120	63.3	7,390	64.7	7,390	66.0	7,400
	130	60.7	6,210	62.1	6,210	63.4	6,220
	140	58.0	5,210	59.4	5,210	60.7	5,210
	150	55.3	4,350	56.7	4,350	57.9	4,350
	160	52.4	3,610	53.8	3,610	55.0	3,620
	170	49.5	2,950	50.8	2,950	51.9	2,960
	180	46.4	2,380	47.7	2,390	48.8	2,390
	190	43.1	1,870	44.4	1,870	45.4	1,880

	45	81.0	19,010*	-	-	-	-
	50	79.8	18,430*	-	-	-	-
	60	77.3	17,300*	78.9	16,380*	80.4	15,320*
	70	74.9	16,270*	76.5	15,530*	77.9	14,730*
	80	72.4	15,250*	74.0	14,680*	75.4	14,040*
	90	69.9	12,910	71.5	12,910	72.9	12,910
	100	67.4	10,760	68.9	10,770	70.3	10,770
	110	64.7	9,050	66.3	9,050	67.6	9,060
200' (61.0 m)	120	62.1	7,640	63.6	7,640	64.9	7,640
	130	59.3	6,460	60.8	6,460	62.1	6,460
	140	56.5	5,460	58.0	5,460	59.3	5,460
	150	53.6	4,600	55.1	4,600	56.3	4,600
	160	50.6	3,860	52.0	3,860	53.2	3,860
	170	47.4	3,200	48.8	3,200	49.9	3,210
	180	44.0	2,620	45.4	2,630	46.5	2,630
	190	40.4	2,120	41.8	2,120	42.8	2,130
	200	36.6	1,670	37.9	1,670	38.8	1,680

50' (15.2 m) Jib length

Boom length	Jib Radius (Feet)	5.0 Deg offset		15.0 Deg offset		25.0 Deg offset	
		Boom Angle	Rating (Pounds)	Boom Angle	Rating (Pounds)	Boom Angle	Rating (Pounds)
	37	80.8	20,630*	-	-	-	-
	40	79.8	20,390*	-	-	-	-
	50	76.6	19,660*	79.2	17,950*	-	-
	60	73.3	18,970*	75.9	17,500*	78.4	16,210*
130' (39.6 m)	70	70.0	18,390*	72.6	16,990*	75.0	15,910*
	80	66.5	17,560	69.1	16,550*	71.5	15,560*
	90	63.0	14,840	65.6	14,840	67.9	14,570*
	100	59.4	12,720	61.9	12,720	64.1	12,730
	110	55.6	11,010	58.1	11,010	60.2	11,020
	120	51.6	9,600	54.0	9,600	56.1	9,610
	130	47.4	8,430	49.8	8,440	51.8	8,440

Boom length	Jib Radius (Feet)	5.0 Deg offset		15.0 Deg offset		25.0 Deg offset	
		Boom Angle	Rating (Pounds)	Boom Angle	Rating (Pounds)	Boom Angle	Rating (Pounds)
	38	81.0	20,560*	-	-	-	-
	40	80.4	20,410*	-	-	-	-
	50	77.3	19,780*	79.8	17,960*	-	-
	60	74.2	19,140*	76.7	17,560*	79.0	16,250*
140' (42.7 m)	70	71.1	18,490*	73.5	17,100*	75.8	15,920*
	80	67.9	17,290	70.3	16,690*	72.5	15,630*
	90	64.6	14,580	67.0	14,580	69.2	14,580
	100	61.2	12,440	63.6	12,450	65.7	12,450
	110	57.6	10,730	60.0	10,740	62.1	10,740
	120	54.0	9,320	56.3	9,330	58.3	9,330
	130	50.1	8,150	52.4	8,160	54.4	8,160
	140	46.0	7,160	48.3	7,160	50.1	7,170

WITH 59HI OFFSET TIP BOOM - 4 SHEAVE TIP, #9HL JIB

52,900 lb + 23,000 lb SC

360°

ANSI B 30.5

50' (15.2 m) Jib length

Boom length	Jib Radius (Feet)	5.0 Deg offset		15.0 Deg offset		25.0 Deg offset	
		Boom Angle	Rating (Pounds)	Boom Angle	Rating (Pounds)	Boom Angle	Rating (Pounds)
	40	80.9	20,440*	-	-	-	-
	50	78.0	19,840*	80.3	17,990*	-	-
	60	75.0	19,230*	77.4	17,540*	79.6	16,160*
	70	72.0	18,650*	74.4	17,150*	76.6	15,930*
150' (45.7 m)	80	69.0	17,030	71.3	16,750*	73.5	15,700*
	90	65.9	14,310	68.2	14,310	70.3	14,320
	100	62.7	12,190	65.0	12,190	67.1	12,190
	110	59.4	10,480	61.7	10,480	63.7	10,480
	120	56.0	9,070	58.3	9,070	60.2	9,070
	130	52.5	7,890	54.7	7,890	56.6	7,890
	140	48.8	6,890	50.9	6,890	52.7	6,900
	150	44.8	6,040	46.9	6,040	48.6	6,050

	42	80.7	20,290*	-	-	-	-
	50	78.5	19,850*	80.8	17,920*	-	-
	60	75.7	19,320*	78.0	17,590*	80.1	16,150*
	70	72.9	18,740*	75.2	17,180*	77.2	15,930*
	80	70.1	16,770	72.3	16,770	74.3	15,700*
	90	67.1	14,050	69.3	14,050	71.3	14,050
160' (48.8 m)	100	64.1	11,910	66.3	11,910	68.3	11,920
	110	61.0	10,200	63.2	10,200	65.1	10,210
	120	57.9	8,790	60.0	8,790	61.9	8,790
	130	54.6	7,610	56.7	7,610	58.5	7,610
	140	51.1	6,610	53.2	6,610	55.0	6,620
	150	47.5	5,760	49.5	5,760	51.2	5,770
	160	43.6	5,020	45.6	5,020	47.2	5,020

	43	80.9	20,220*	-	-	-	-
	50	79.1	19,890*	-	-	-	-
	60	76.4	19,340*	78.6	17,580*	80.6	16,110*
	70	73.7	18,760*	75.9	17,230*	77.9	15,880*
	80	71.0	16,520	73.1	16,530	75.1	15,660*
	90	68.2	13,800	70.3	13,800	72.3	13,810
170' (51.8 m)	100	65.4	11,670	67.5	11,670	69.4	11,670
	110	62.5	9,950	64.6	9,960	66.4	9,960
	120	59.5	8,540	61.5	8,540	63.4	8,550
	130	56.4	7,360	58.4	7,360	60.2	7,370
	140	53.2	6,370	55.2	6,370	56.9	6,380
	150	49.9	5,510	51.8	5,520	53.5	5,520
	160	46.3	4,770	48.3	4,770	49.8	4,770
	170	42.6	4,120	44.5	4,120	45.9	4,130

	45	80.8	20,090*	-	-	-	-
	50	79.5	19,810*	-	-	-	-
	60	77.0	19,340*	79.1	17,500*	-	-
	70	74.4	18,840*	76.5	17,200*	78.4	15,850*
	80	71.8	16,260	73.9	16,260	75.8	15,670*
	90	69.2	13,530	71.2	13,540	73.1	13,540
180' (54.9 m)	100	66.5	11,400	68.5	11,400	70.3	11,410
	110	63.8	9,690	65.8	9,690	67.5	9,690
	120	61.0	8,280	62.9	8,280	64.7	8,280
	130	58.1	7,090	60.0	7,100	61.7	7,100
	140	55.1	6,090	57.0	6,100	58.6	6,100
	150	51.9	5,230	53.8	5,240	55.4	5,240
	160	48.7	4,500	50.6	4,500	52.1	4,500
	170	45.2	3,840	47.1	3,840	48.5	3,850
	180	41.6	3,280	43.4	3,280	44.7	3,280

Boom length	Jib Radius (Feet)	5.0 Deg offset		15.0 Deg offset		25.0 Deg offset	
		Boom Angle	Rating (Pounds)	Boom Angle	Rating (Pounds)	Boom Angle	Rating (Pounds)
	46	80.9	19,870*	-	-	-	-
	50	80.0	19,680*	-	-	-	-
	60	77.6	19,240*	79.5	17,430*	-	-
	70	75.1	18,190*	77.1	16,950*	78.9	15,670*
	80	72.6	16,000	74.6	16,010	76.4	15,180*
	90	70.1	13,280	72.1	13,280	73.8	13,280
190' (57.9 m)	100	67.6	11,150	69.5	11,150	71.2	11,150
	110	64.9	9,430	66.9	9,430	68.6	9,440
	120	62.3	8,020	64.2	8,020	65.9	8,020
	130	59.5	6,840	61.4	6,840	63.1	6,840
	140	56.7	5,840	58.6	5,840	60.2	5,840
	150	53.8	4,980	55.6	4,980	57.2	4,980
	160	50.8	4,230	52.6	4,230	54.1	4,230
	170	47.6	3,580	49.4	3,580	50.8	3,590
	180	44.2	3,000	46.0	3,010	47.4	3,010
	190	40.6	2,500	42.3	2,500	43.6	2,510

	48	80.8	17,880*	-	-	-	-
	50	80.4	17,660*	-	-	-	-
	60	78.1	16,610*	80.0	15,350*	-	-
	70	75.7	15,590*	77.6	14,620*	79.4	13,570*
	80	73.3	14,650*	75.2	13,910*	77.0	13,060*
	90	70.9	13,010	72.8	13,020	74.5	12,530*
	100	68.5	10,880	70.3	10,880	72.0	10,890
	110	66.0	9,160	67.9	9,160	69.5	9,160
200' (61.0 m)	120	63.5	7,740	65.3	7,740	66.9	7,750
	130	60.9	6,570	62.7	6,570	64.3	6,580
	140	58.2	5,560	60.0	5,560	61.6	5,570
	150	55.5	4,710	57.2	4,710	58.8	4,720
	160	52.6	3,960	54.4	3,960	55.8	3,970
	170	49.7	3,310	51.4	3,310	52.8	3,320
	180	46.6	2,730	48.3	2,740	49.6	2,740
	190	43.3	2,220	44.9	2,220	46.2	2,230
	200	39.8	1,780	41.4	1,780	42.6	1,780

CRAWLER CRANE HC 110

WITH 59HI OFFSET TIP BOOM - 4 SHEAVE TIP, #9HL JIB

52,900 lb + 23,000 lb SC

360°

ANSI B 30.5

50' (18.3 m) Jib length

Boom length	Jib Radius (Feet)	5.0 Deg offset		15.0 Deg offset		25.0 Deg offset	
		Boom Angle	Rating (Pounds)	Boom Angle	Rating (Pounds)	Boom Angle	Rating (Pounds)
	42	81.0	15,360*	-	-	-	-
	50	78.8	14,930*	-	-	-	-
	60	76.0	14,330*	78.7	12,880*	-	-
	70	73.2	13,790*	75.9	12,470*	78.4	11,300*
150' (45.7 m)	80	70.3	13,300*	73.0	11,980*	75.5	10,950*
	90	67.4	12,800*	70.0	11,530*	72.5	10,620*
	100	64.4	12,230*	67.0	11,170*	69.4	10,320*
	110	61.3	10,570	63.9	10,570	66.2	10,080*
	120	58.1	9,170	60.7	9,170	63.0	9,180
	130	54.8	7,990	57.4	7,990	59.6	8,000
	140	51.4	6,990	53.9	6,990	56.0	7,000
	150	47.7	6,130	50.2	6,140	52.3	6,140

	44	80.9	15,280*	-	-	-	-
	50	79.3	14,940*	-	-	-	-
	60	76.6	14,400*	79.2	12,910*	-	-
	70	73.9	13,890*	76.5	12,570*	78.9	11,360*
	80	71.2	13,440*	73.8	12,090*	76.2	11,010*
	90	68.4	12,970*	71.0	11,690*	73.3	10,660*
160' (48.8 m)	100	65.6	12,020	68.1	11,280*	70.4	10,400*
	110	62.7	10,30	65.2	10,310	67.5	10,140*
	120	59.7	8,890	62.2	8,890	64.4	8,900
	130	56.6	7,710	59.1	7,710	61.2	7,720
	140	53.4	6,710	55.8	6,710	57.9	6,720
	150	50.1	5,850	52.5	5,860	54.5	5,860
	160	46.5	5,120	48.9	5,120	50.8	5,120

	46	80.8	15,200*	-	-	-	-
	50	79.8	15,010*	-	-	-	-
	60	77.2	14,470*	79.7	12,920*	-	-
	70	74.7	13,970*	77.1	12,610*	79.5	11,390*
	80	72.1	13,510*	74.5	12,210*	76.8	11,070*
	90	69.4	13,120*	71.9	11,790*	74.1	10,760*
170' (51.8 m)	100	66.7	11,770	69.2	11,380*	71.4	10,470*
	110	64.0	10,060	66.4	10,060	68.6	10,060
	120	61.2	8,650	63.5	8,650	65.7	8,650
	130	58.3	7,460	60.6	7,470	62.7	7,470
	140	55.3	6,460	57.6	6,470	59.6	6,470
	150	52.2	5,600	54.5	5,610	56.4	5,610
	160	48.9	4,870	51.2	4,870	53.1	4,870
	170	45.5	4,220	47.7	4,220	49.5	4,230

Boom length	Jib Radius (Feet)	5.0 Deg offset		15.0 Deg offset		25.0 Deg offset	
		Boom Angle	Rating (Pounds)	Boom Angle	Rating (Pounds)	Boom Angle	Rating (Pounds)
	47	80.9	15,170*	-	-	-	-
	50	80.2	15,030*	-	-	-	-
	60	77.8	14,540*	80.1	12,970*	-	-
	70	75.3	14,050*	77.7	12,640*	79.9	11,460*
	80	72.8	13,640*	75.2	12,320*	77.4	11,130*
	90	70.3	13,200*	72.7	11,890*	74.8	10,840*
180' (54.9 m)	100	67.8	11,510	70.1	11,510	72.2	10,560*
	110	65.2	9,790	67.5	9,790	69.5	9,800
	120	62.5	8,380	64.8	8,380	66.8	8,390
	130	59.7	7,200	62.0	7,200	64.0	7,200
	140	56.9	6,200	59.2	6,200	61.1	6,200
	150	54.0	5,340	56.2	5,340	58.1	5,340
	160	51.0	4,590	53.2	4,590	55.0	4,600
	170	47.8	3,940	49.9	3,940	51.7	3,950
	180	44.4	3,370	46.5	3,370	48.2	3,370

	49	80.8	15,040*	-	-	-	-
	50	80.6	14,990*	-	-	-	-
	60	78.3	14,550*	80.5	12,920*	-	-
	70	75.9	14,080*	78.2	12,620*	80.3	11,440*
	80	73.5	13,650*	75.8	12,330*	77.9	11,180*
	90	71.1	13,290*	73.4	12,000*	75.5	10,870*
190' (57.9 m)	100	68.7	11,250	70.9	11,250	73.0	10,610*
	110	66.2	9,530	68.4	9,530	70.4	9,530
	120	63.7	8,110	65.9	8,120	67.9	8,120
	130	61.1	6,940	63.3	6,940	65.2	6,950
	140	58.4	5,930	60.6	5,930	62.5	5,940
	150	55.7	5,080	57.8	5,080	59.7	5,090
	160	52.8	4,330	54.9	4,330	56.7	4,340
	170	49.9	3,680	51.9	3,680	53.7	3,690
	180	46.8	3,100	48.8	3,110	50.5	3,110
	190	43.5	2,600	45.5	2,600	47.1	2,610

	50	80.9	15,000*	-	-	-	-
	60	78.7	14,550*	80.9	12,920*	-	-
	70	76.5	14,090*	78.7	12,660*	80.7	11,200*
	80	74.2	13,710*	76.4	12,380*	78.4	11,200*
	90	71.9	13,120	74.1	12,090*	76.1	10,940*
	100	69.6	10,980	71.7	10,990	73.7	10,650*
200' (61.0 m)	110	67.2	9,260	69.3	9,260	71.3	9,270
	120	64.8	7,850	66.9	7,850	68.8	7,850
	130	62.3	6,660	64.4	6,670	66.3	6,670
	140	59.8	5,660	61.8	5,660	63.7	5,670
	150	57.2	4,800	59.2	4,800	61.0	4,810
	160	54.5	4,060	56.5	4,060	58.3	4,070
	170	51.7	3,400	53.7	3,410	55.4	3,410
	180	48.8	2,830	50.8	2,830	52.5	2,830
	190	45.8	2,320	47.7	2,320	49.3	2,330
	200	42.6	1,860	44.5	1,870	46.0	1,870

WITH 59HI OFFSET TIP BOOM - 4 SHEAVE TIP, #9HL JIB

52,900 lb + 23,000 lb SC

360°

ANSI B 30.5

70' (21.3 m) Jib length

Boom length	Jib Radius (Feet)	5.0 Deg offset		15.0 Deg offset		25.0 Deg offset	
		Boom Angle	Rating (Pounds)	Boom Angle	Rating (Pounds)	Boom Angle	Rating (Pounds)
	50	80.8	11,850*	-	-	-	-
	60	78.5	11,380*	-	-	-	-
	70	76.1	10,940*	78.8	9,530*	-	-
	80	73.7	10,510*	76.4	9,140*	78.9	8,120*
	90	71.3	10,010*	74.0	8,790*	76.4	7,860*
	100	68.9	9,590*	71.5	8,450*	73.9	7,650*
180' (54.9 m)	110	66.4	9,160*	69.0	8,180*	71.4	7,430*
	120	63.9	8,450	66.4	7,900*	68.8	7,250*
	130	61.3	7,270	63.8	7,270	66.1	7,060*
	140	58.6	6,270	61.1	6,270	63.4	6,280
	150	55.9	5,420	58.4	5,420	60.6	5,430
	160	53.0	4,670	55.5	4,670	57.6	4,680
	170	50.0	4,020	52.5	4,020	54.6	4,030
	180	46.9	3,440	49.4	3,450	51.4	3,450

	51	80.9	11,820*	-	-	-	-
	60	78.9	11,450*	-	-	-	-
	70	76.7	11,030*	79.2	9,580*	-	-
	80	74.4	10,640*	76.9	9,220*	79.3	8,160*
	90	72.1	10,130*	74.6	8,870*	77.0	7,920*
	100	69.7	9,710*	72.3	8,540*	74.6	7,690*
190' (57.9 m)	110	67.4	9,300*	69.9	8,250*	72.2	7,490*
	120	65.0	8,200	67.4	8,000*	69.7	7,310*
	130	62.5	7,010	64.9	7,020	67.2	7,020
	140	60.0	6,010	62.4	6,020	64.6	6,020
	150	57.4	5,150	59.8	5,150	61.9	5,160
	160	54.7	4,410	57.1	4,410	59.2	4,420
	170	51.9	3,750	54.3	3,760	56.3	3,760
	180	49.0	3,190	51.3	3,190	53.3	3,190
	190	46.0	2,670	48.3	2,670	50.2	2,680

Boom length	Jib Radius (Feet)	5.0 Deg offset		15.0 Deg offset		25.0 Deg offset	
		Boom Angle	Rating (Pounds)	Boom Angle	Rating (Pounds)	Boom Angle	Rating (Pounds)
	53	80.8	11,750*	-	-	-	-
	60	79.3	11,490*	-	-	-	-
	70	77.2	11,070*	79.6	9,620*	-	-
	80	75.0	10,680*	77.4	9,260*	79.7	8,200*
	90	72.8	10,280*	75.2	8,950*	77.5	7,940*
	100	70.5	9,820*	73.0	8,630*	75.2	7,740*
200' (61.0 m)	110	68.3	9,340	70.7	8,340*	72.9	7,540*
	120	65.9	7,930	68.3	7,930	70.5	7,350*
	130	63.6	6,750	66.0	6,750	68.1	6,760
	140	61.2	5,750	63.5	5,750	65.7	5,750
	150	58.7	4,880	61.1	4,890	63.1	4,890
	160	56.2	4,130	58.5	4,140	60.5	4,140
	170	53.6	3,480	55.9	3,490	57.8	3,490
	180	50.8	2,910	53.1	2,910	55.0	2,920
	190	48.0	2,400	50.3	2,400	52.1	2,410
	200	45.0	1,940	47.3	1,950	49.0	1,950

NOTES TO LIFTING CAPACITY

⚠ Warning

This rating chart is invalid if the crane has been modified or altered by use of other than GENUINE AMERICAN PARTS as such modifications or alterations may affect its capacity or safe operation. See American Crane Corporation Service Bulletin #259.

Ratings in this chart are in POUNDS and do not exceed the percentage of tipping specified for this crane by ANSI B30.5. All ratings require that the crane be standing level on a firm uniformly supporting surface.

Do not lift loads in excess of those shown on this chart. Lifting loads in excess of those shown or operation not in accordance with good operating practice, including limitations shown on page 3499 of Operator's Manual, can cause tipping, structural damage or catastrophic failure.

Asterisk (*) areas on this chart indicate ratings that are limited by strength of material or factors other than stability (tipping).

„RADIUS IN FEET“ is the horizontal distance at ground level from the crane centerline of rotation to a vertical line through the center of gravity of the suspended load. When using the main boom fall with jib in place, the main fall ratings must be reduced by the jib effective weight shown on the jib rating chart plus twice the weight of all suspended blocks, slings, rope, etc., at the jib fall. See Appendix A.

When using the main boom fall with boom tip extension in place, the main fall ratings must be reduced by the weight of the boom tip extension plus twice the weight of all suspended blocks, slings, rope, etc., at the boom tip extension fall. See Appendix A.

Blocks, slings, buckets and other load carrying devices are considered part of the load. The weight of standard hoisting ropes for the rating at a given radius has been calculated as part of the boom point load and need not be considered in determining net allowable loads. See Appendix A.

Ratings shown on this chart make no allowance for such factors as out of plumb loads, wind, poor soil conditions, improper inflation of rubber tires and dynamic effects due to excessive operating speeds. The user (operator) must exercise judgment to make allowance for these conditions. See page 3499 of Operator's Manual for detailed information.

No account is taken of the wind force on the load. This effect, which can be substantial for loads with large surface areas, must be considered by the user. In any wind it is strongly recommended that taglines be used to control the load.

BOOM HOIST LINE – 12 parts of 3/4 inch diameter IPS wire rope with a minimum breaking strength of 51,200 pounds.

PENDANT SUSPENSION LINE – 2 parts of 1-3/8 inch diameter EEIPS wire rope with a minimum breaking strength of 211,000 pounds.

JIB BACKSTAY AND FRONTSTAY LINES – 2 parts of 0.875 inch diameter IPS wire rope with a minimum breaking strength of 69,200 pounds.

JIB WHIP LINE – 7/8 inch diameter EIPS wire rope with a minimum breaking strength of 79,600 pounds.

SIDEFAME POSITION DEFINITIONS

These ratings are valid for the sideframe positions as indicated below.

Refer to the HC 110 Operator's Manual for additional information.

ERECTION

Erection „OVER-THE-END BLOCKED“ is with the boom over the idler end with idler tumblers blocked (See HC 110 Operator's Manual for blocking instructions). Erection „OVER-THE-SIDE“ is with the boom 90° to the sideframes. Blocks, slings and other load carrying devices must be on the ground during erection.

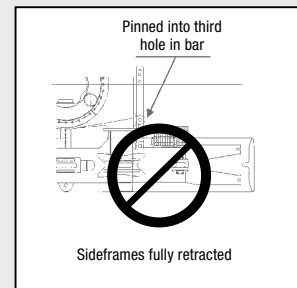
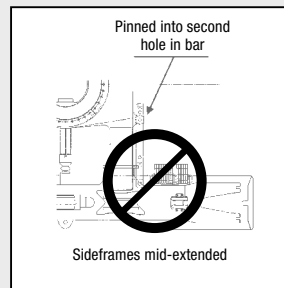
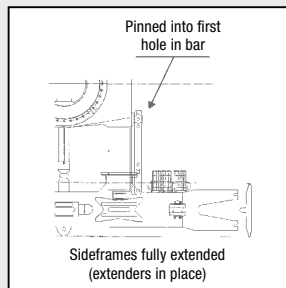

59HI OFFSET TIP BOOM MAXIMUM BOOM & JIB SELF-ERECTION DATA				
JIB	OVER-THE-END BLOCKED		OVER-THE-SIDE	
			SIDEFRAMES FULLY-EXTENDED (WITH EXTENDERS IN PLACE)	
	BOOM LENGTH (FEET)	JIB LENGTH (FEET)	BOOM LENGTH (FEET)	JIB LENGTH (FEET)
9HL	230	0	210	0
	220	0	200	0
	210	40	190	40
	200	70	180	70

BOOM LENGTH (FEET)	BOOM COMPOSITION CHART - 59HI OFFSET TIP				
	BOOM SECTIONS				
	25' 59HI INNER	10' 59HI CENTER	20' 59HI CENTER	40' 59HI CENTER	25' 59HI OUTER
100	1	1	0	1	1
110	1	0	1	1	1
120	1	1	1	1	1
130	1	0	0	2	1
140	1	1	0	2	1
150	1	0	1	2	1
160	1	1	1	2	1
170	1	0	0	3	1
180	1	1	0	3	1
190	1	0	1	3	1
200	1	1	1	3	1
210	1	0	0	4	1

LOAD HOISTING INFORMATION - 7/8" diameter EIPS wire rope			
MAXIMUM LIFTING CAPACITY - LBS.	MINIMUM PARTS OF LINE	MAXIMUM HOISTING DISTANCE - FEET	
		MAIN HOIST	AUX HOIST
22,550	1	N/A	626

9HL JIB COMPOSITION CHART								
JIB LENGTH (FEET)	20' INNER	10' CENTER	20' CENTER	20' OUTER	EFF. JIB WEIGHT (POUNDS)	JIB OFFSET "A" IN FEET & INCHES		
						5°	15°	25°
						40	1	0
50	1	1	0	1	2,350	5' 6"	11' 8"	17' 9"
60	1	0	1	1	2,750	6' 1"	13' 6"	20' 9"
70	1	1	1	1	3,700	6' 8"	15' 6"	24' 0"

TECHNICAL DESCRIPTION

HYDRAULIC CRAWLER CRANE

Maximum lifting capacity

110 tons (100 mt).

Boom systems

59HI Tubular Chord Boom, pin connected – with 4 Sheave Tip

- 230 ft maximum boom length.
- 270 ft maximum boom and jib combination length.
- 25 ft (7.6 m) inner and 25 ft (7.6 m) outer and 10 ft / 20 ft / 40 ft available inserts provide boom compositions in 10 ft (3 m) increments from 50 ft (15.2 m) to 230 ft (70 m).

Robust engine

- Cummins Model QSB 6.7 Turbocharged, after cooler, diesel engine, 4 cycle, 6 cylinders, direct fuel injection, 409 cubic inch displacement, 6.7 liters, 240 BHP@2000 rpm, 105 gallons fuel tank capacity.

Environmental operator's cab

- Designed to provide excellent viewing range and quiet, comfortable operation.
- 37 inch (0.91 m) wide cab has wide curved windows on both top and bottom.
- Easy-to-operate modular and ergonomically designed controls reduce operator fatigue and increase productivity.
- Load Moment Indicator with interactive screen. Operator can select from three display modes: loaded condition diagram, rated lifting curve or rated lifting load table.
- Adjustable operator's seat, radio, air conditioner, overhead window, sun visor, fan, overhead and front wipers and drum rotation indicators are standard.

Heavy duty carbody and crawlers

- Fabricated steel carbody is deep box constructed with square axles for the crawler side frames. Precision machined top supports anti-friction swing circle and multiple pass hydraulic swivel joint.
- Crawlers have high alloy steel tumbler yokes and rigid fabricated structures with sealed rollers.
- 36" (914 mm) crawler shoes.
- Travel mechanism is set within shoe width.
- Side frames extended or retracted by cylinders inside the carbody.
- Two travel speed settings – 0.60 / 0.87 mph (0.96 / 1.4 km/h).
- 30 % (17°) gradeability.

Powerful, high-speed hoist system

- Independent main and auxiliary load hoisting drums. Main drum is grooved for 1 inch (25 mm) diameter rope. Max line speed is 513 fpm (156 m/min), max single line pull is 40,640 lb (18 435 kg). Rated single line pull is 29,500 lb (13 381 kg). Auxiliary drum is grooved for 7/8 inch (22.4 mm) diameter rope. Max line speed is 553 fpm (168 m/min), max single line pull is 37,670 lb (17 086 kg). Rated single line pull is 22,700 lb (10 297 kg). Freefall on main and auxiliary drums.
- Each drum, including optional third, has power up/down and freefall. Load hoists are further controllable in stepless mode.
- Ample work space in front of the drums allows easy access for cable installation and maintenance.
- External contracting brake.
- Internal expanding band clutch.
- 3.0 rpm swing speed.

High capacity, dependable hydraulic system

- Open circuit system has 2 variable displacement piston pumps with system capacity of 183 gpm (692 lpm).
- Hydraulic reservoir with 79 gallons (300 l) capacity and 10 micron filtration.
- Component working range is between -4 and 203° F (-20 and 95° C).

Four piece removable counterweight

- Four piece pin connected counterweight can be assembled or disassembled easily within minutes.
- Hydraulic counterweight removal system is standard and makes the HC 110 one of the most transportable cranes in its class.
- Moves on five trucks with full boom and #9HL jib. At 17 ft, 0.5 inch (5.2 m) wide and 11 ft (3.35 m) high, the basic HC 110 will transport on a standard lowboy trailer.

Options include

- Third drum
- Third drum with free spooling
- Automotive type lights
- Hydraulic power take off
- Jib and jib inserts
- Single sheave extension
- Luffing jib
- Transportation package
- Single sheave extension
- Tagline winder

TRANSPORT EXAMPLE FOR HC 110

WITH 200 FT 59”H BOOM & 70 FT JIB AND 3RD DRUM

Loads required as follows (weights shown do not include blocking or tie-down material):

LOAD NO. 1 – Step Deck

2 x crawler side frame counterweights (11,500 each)	23,000 lbs
40’ boom center section with pendants	2,670 lbs
20 ft jib inner	890 lbs
1 x upper counterweight	4,400 lbs
TOTAL LOAD	30,960 lbs

LOAD NO. 2 – Step Deck

Middle portion of counterweight	12,100 lbs
40’ boom center section	2,670 lbs
20 ft jib outer	480 lbs
1 x upper counterweight	4,400 lbs
TOTAL LOAD	19,650 lbs

LOAD NO. 3 – Step Deck

Lower portion of counterweight	32,000 lbs
25 ft boom outer section	4,200 lbs
20’ boom center section	1,975 lbs
Main load block	1,500 lbs
Overhaul ball	650 lbs
TOTAL LOAD	40,325 lbs

LOAD NO. 4 – Step Deck

1 x 10’ boom center section	1,060 lbs
1 x 40’ boom center sections	2,670 lbs
10’ jib center section	190 lbs
20’ jib center section	385 lbs
TOTAL LOAD	4,305 lbs

LOAD NO. 5

Basic Crane:

- a) Complete upper structure
- b) Carbody and sideframes
- c) Retractable A-frame
- d) Boom inner section and boom stops
- e) Third drum

TOTAL WEIGHT OF BASIC CRANE, etc.)	105,000 lbs
---	--------------------

KEY

-  Counterweight
- SC Sideframe Counterweight

The information contained in this brochure merely consists of general descriptions and a broad compilation of performance features which might not apply precisely as described under specific application conditions or which may change as a result of further product development. The desired performance features only become binding once expressly agreed in the final contract.

Note: Data published herein is intended as a guide only and shall not be construed to warrant applicability for lifting purposes. Crane operation is subject to the computer charts and operation manual both supplied with the crane.

Subject to change without notice.

12 / 06