

**TEREX**  **CRANES**

**A300**



**simple, available and cost effective™**

[www.terex-cranes.com](http://www.terex-cranes.com)

Crane performance data	
Capacity at 3 m from slewing ring axis (CE / 85% SAE J765)	30 / 32 t
Boom length (retracted / extended)	8.0 / 24.0 m
Boom head height	26.0 m

Truck performance data <sup>(1)</sup>	
Max. travelling speed (on 14.00R24 tyres)	34 km/h
Max. travelling speed (on 16.00R25 tyres)	36 km/h
Max. theoretical ramp during operation (on 14.00R24 tyres)	119 %
Max. theoretical ramp during operation (on 16.00R25 tyres)	99 %

<sup>(1)</sup>Standard crane in operating conditions: no auxiliary winch and no extensions

Weights <sup>(2)</sup>		
1 <sup>st</sup> axle	2 <sup>nd</sup> axle	Total
11.5 t	12.9 t	24.4 t

<sup>(2)</sup>Standard crane: no auxiliary winch and no extensions, on 14.00R24 tyres

Operating speed / times <sup>(3)</sup>	
Winch (max. speed under direct pull)	77 m/min
Telescopic boom lifting / lowering	35 / 45 s
Telescopic boom extension / retraction (8.05 m to 18.75 m)	50 / 25 s
Upper structure slewing	35 s
Extension of single outrigger beam	20 s
Extension of single outrigger	25 s

<sup>(3)</sup>Average reference indicative values

Truck	
Traction/Steering	4x4x4
Frame	With twin body side member. Front tow point (back tow point on request)
Outriggers	no. 4 independent hydraulic outriggers onto hydraulic beams. Outrigger beams can be fully retracted, partially or fully extended. Outrigger controls in the operating cab
Engine	CUMMINS B5.9-C: no. 6 in-line cylinders - displacement 5.88 cu dm - water cooling - turbo supercharger. Max. power 101 kW at 2200 rpm - Max. torque 561 Nm at 1500 rpm. 97/68/CE Step 1 approved
Tank	240 l
Transmission	DANA series 20000: Powershift-type transmission with torque converter. 3 + 3 forward speeds and 3 + 3 reverse speed: slow and fast speed mode. Automatic engagement of 4WD after selecting slow speed mode
Brakes	Operating brakes: double-circuit hydro-pneumatic drum brakes on all wheels. Parking / Emergency brake: negative action onto front transmission shaft. Pneumatic spring brake
Axles	no. 2 driving / steering axles equipped with planetary gearboxes into hubs. On request: differential locks
Suspension	Stiff suspension for front axle, swinging suspension for rear axle. Rear suspension is automatically locked by hydraulic jacks if lifting boom is not aligned with centreline within front crane area
Steering	Hydrostatic steering controlled by steering wheel into the operating cab. Steering of front axle alone or both axles in concentric or crab mode.
Tyres	no. 4 14.00R24 tyres On request, no. 4 16.00R25 tubeless tyres

Upper structure	
Boom	no. 4 rectangular elements
Lifting	no. 1 double action hydraulic jack. Boom inclination: -2° to +78°
Extension	Continuous proportional extension of elements 2 and 3 through double action hydraulic jack and inner chain-driven system. Extension of element 4 through hydraulic jack by means of outer manual drift, manually locked. Extension under partial load possible
Winch	Controlled by fixed displacement hydraulic motor equipped with axial pistons and planetary gearbox. Automatic negative brake for winch lowering. Cable tensioner. Rope diameter 15 mm length 140 m. Max. lifting capacity 3800 daN
Slewing	360° non-stop rotation controlled by hydraulic motor equipped with planetary gearbox on slewing ring having double ball ring and outer toothing. Automatic negative brake
Operating cab	Sliding door. Wide visibility. Equipped with heating system. Front and upper anti-breaking window with windscreen wiper. Upper and back windows can be opened. Operator's seat position adjustable on guides . Spring suspension. Hand controls for crane control included in the instrument panel
Safety	Stop valves onto extension / lifting boom jacks and outriggers. Max. pressure valves for each hydraulic circuit. Balancing braking valve for the slewing unit. Balancing braking valve for the winch. Limit switch onto boom head for hoisting block lift. Limit switch for having three winding turns around the winch. Load limiting device with indicator for: <ul style="list-style-type: none"> <li>Boom inclination</li> <li>Boom length</li> <li>Load weight</li> <li>Max. load which can be lifted</li> </ul>

Systems	
Hydraulic system	Feeding: no. 1 double gear pump, no. 1 single gear pump and no. 1 double vane pump. Movement control: distributors controlled by hydraulic hand controls. More proportional operations can be carried out at the same time. Outrigger control: solenoid valves controlled by separate buttons. Filtering: no. 1 cartridge filter in return circuit
Electric system	24 V, 75 A generator and no. 2 132 Ah batteries. Lighting devices in compliance with current EU directives.
Pneumatic system	190 cu cm compressor, no. 2 45 l reservoirs. Auxiliary air intake and tyre inflating kit

## OPTIONS

Additional pulley onto boom head
"A" 4-m tubular jib Inclination at 10° or 25°
Lattice extension 7.6 m long
Lattice extension 7.6 m + 6.8 m long Inclination at 3°, 16° or 30°
Air conditioning in operating cab
Spare wheel
Operating kit for temperatures up to -20°C
Operating kit for temperatures up to +45°C
Heat exchanger for oil cooling-down

# Capacità di sollevamento, altezze e raggio

## Charges, hauteurs et portées

### Lifting capacities, heights and radius

### Traglasten / Hubhöhen

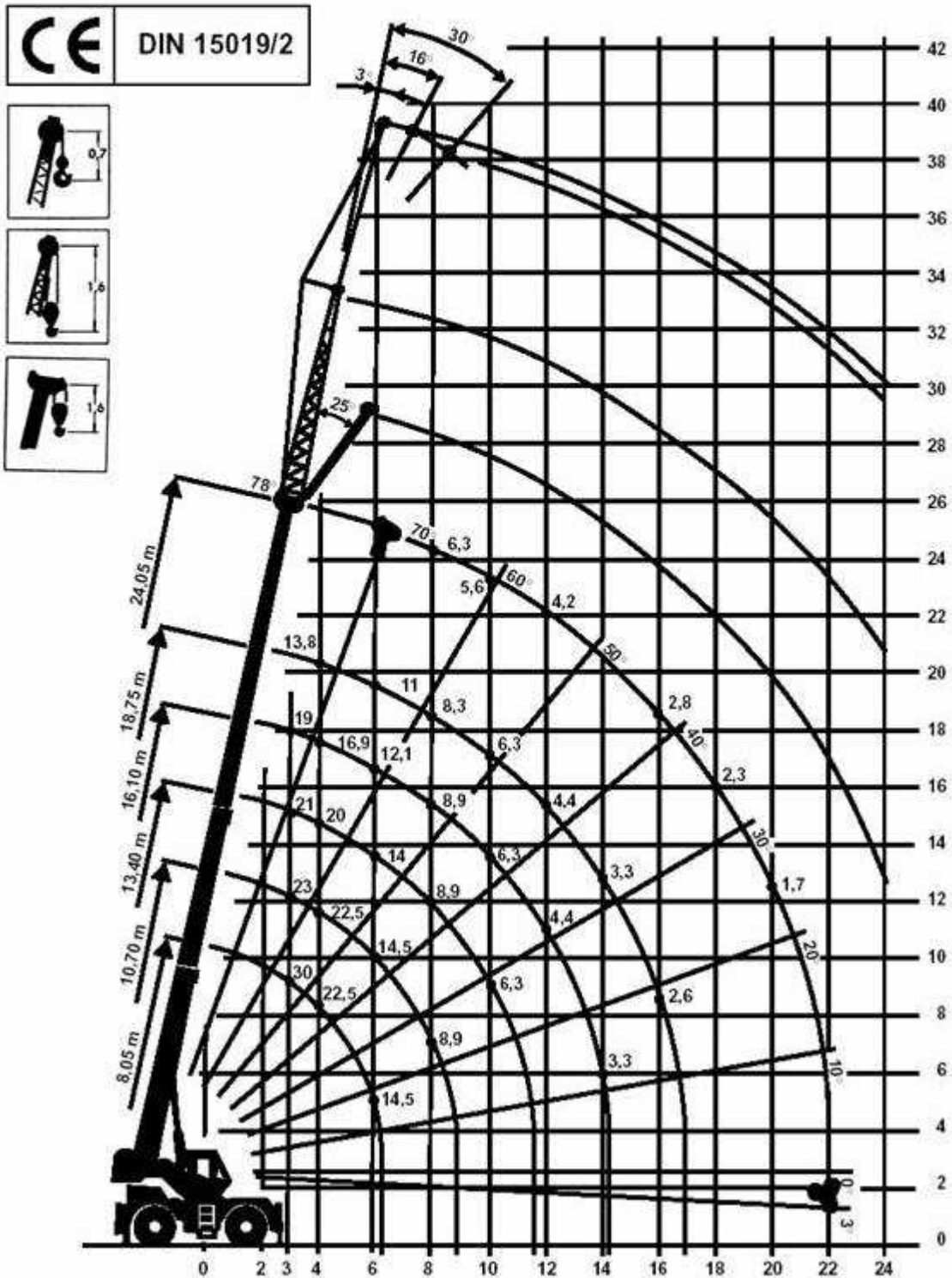

# Capacità di sollevamento, altezze e raggio

## Charges, hauteurs et portées



### Lifting capacities, heights and radius

### Traglasten / Hubhöhen

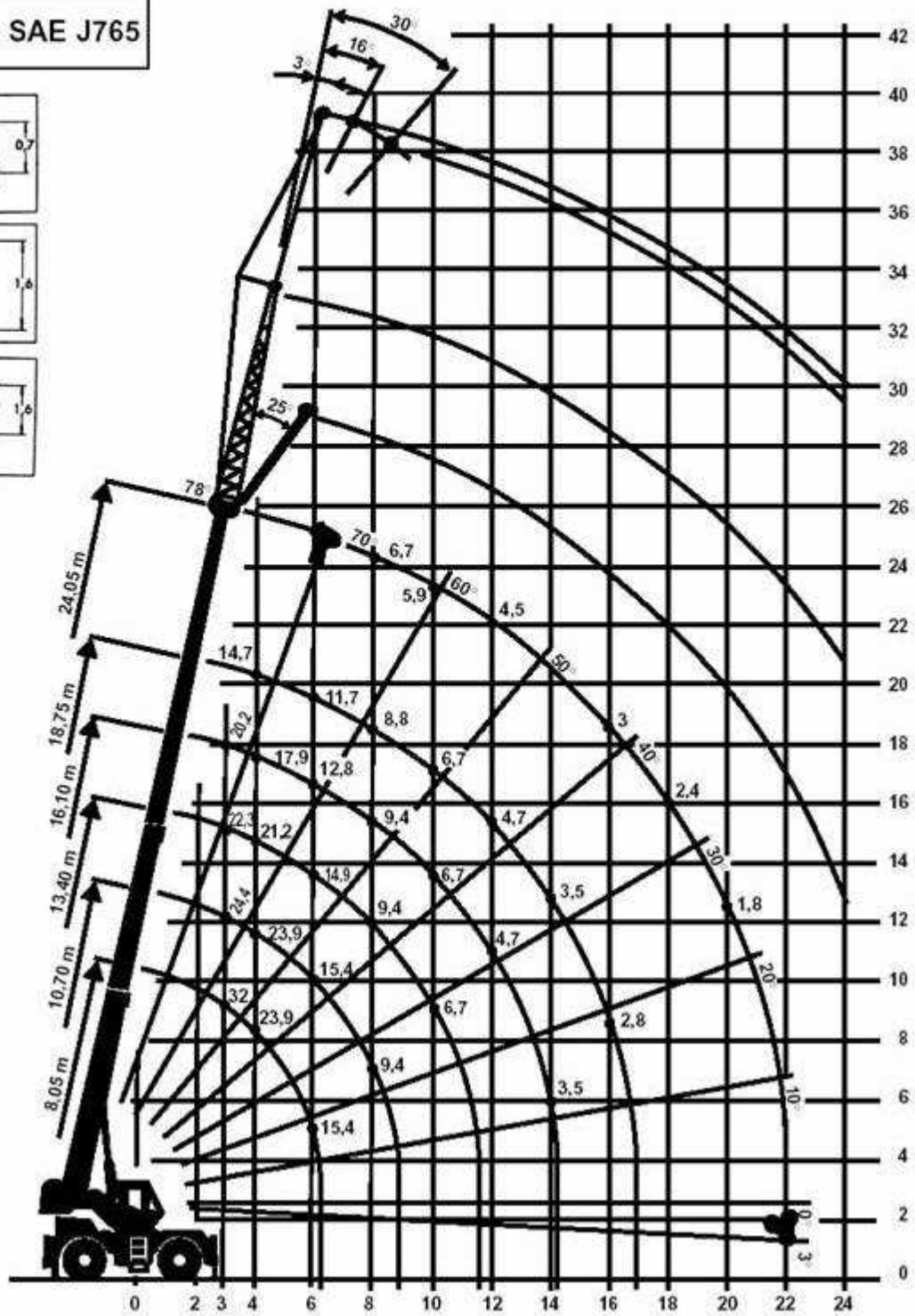

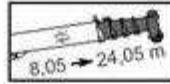
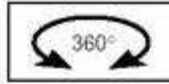
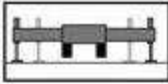
85% SAE J765





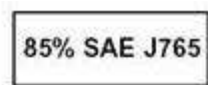
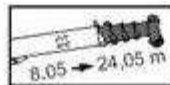
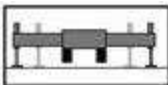











	BRACCIO PRINCIPALE / MAIN BOOM HAUPTAUSLEGER / FLECHE PRINCIPALE						
	8,05 m	10,70 m	13,40 m	16,10 m	18,75 m	24,05 m	
	DIN	DIN	DIN	DIN	DIN	DIN	
3	30,00	23,00	21,00	19,00			3
4	22,50	22,50	20,00	16,90	13,80		4
5	18,00	18,00	17,00	14,00	12,50	8,40	5
6	14,50	14,50	14,00	12,10	11,00	8,00	6
7		11,20	11,20	10,60	9,50	7,00	7
8		8,90	8,90	8,90	8,30	6,30	8
9			7,50	7,50	7,20	5,80	9
10			6,30	6,30	6,30	5,60	10
12				4,40	4,40	4,20	12
14				3,30	3,30	3,50	14
16					2,60	2,80	16
18						2,30	18
20						1,70	20
22						1,50	22
24							24
26							26
28							28









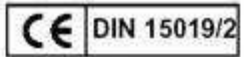
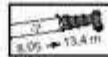
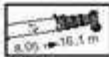





	BRACCIO PRINCIPALE / MAIN BOOM HAUPTAUSLEGER / FLECHE PRINCIPALE						
	8,05 m	10,70 m	13,40 m	16,10 m	18,75 m	24,05 m	
	85%	85%	85%	85%	85%	85%	
3	32,00	24,40	22,30	20,20			3
4	23,90	23,90	21,20	17,90	14,70		4
5	19,10	19,10	18,00	14,90	13,30	8,90	5
6	15,40	15,40	14,90	12,80	11,70	8,50	6
7		11,90	11,90	11,30	10,10	7,40	7
8		9,40	9,40	9,40	8,80	6,70	8
9			8,00	8,00	7,60	6,20	9
10			6,70	6,70	6,70	5,90	10
12				4,70	4,70	4,50	12
14				3,50	3,50	3,70	14
16					2,80	3,00	16
18						2,40	18
20						1,80	20
22						1,60	22
24							24
26							26
28							28



	14.00 R 24								STATICHE / STATIONARY / STATIQUE / STATISCH			IN TRASLAZIONE 3 KM/H / PICK AND CARRY UP TO 3 KM/H EN TRANSLATION JUSQU'À 3 KM/H / VERFAHRBAR			
	SETTORE FRONTALE / OVER FRONT / SUR L'AVANT / NACH VORNE ± 3°				SU 360° / OVER 360° / SUR 360° / BEI 360°				SETTORE FRONTALE / OVER FRONT / SUR L'AVANT / NACH VORNE ± 3°						
	8,05 m	10,70 m	13,40 m	16,10 m	8,05 m	10,70 m	13,40 m	8,05 m	10,70 m	13,40 m					
															
DIN	DIN	DIN	DIN	DIN	DIN	DIN	DIN	DIN	DIN	DIN					
3	17,50				10,80			14,50			3				
3,5	14,75				9,30			13,00			3,5				
4	12,00	12,00			7,80	7,80		11,50	11,50		4				
4,5	10,20	10,20			6,45	6,45		9,75	9,75		4,5				
5	8,40	8,40	8,40		5,10	5,10	5,10	8,00	8,00	8,00	5				
6		6,00	6,00	6,00		3,90	3,90		6,00	6,00	6				
7		5,00	5,00	5,00		2,90	2,90		5,00	5,00	7				
8			3,70	3,70			2,15			3,60	8				
9			3,10	3,10			1,60			3,00	9				
10			2,40	2,40						2,30	10				
12				1,50							12				
14				1,10							14				
16											16				



	16.00 R 25								STATICHE / STATIONARY / STATIQUE / STATISCH			IN TRASLAZIONE 3 KM/H / PICK AND CARRY UP TO 3 KM/H EN TRANSLATION JUSQU'À 3 KM/H / VERFAHRBAR			
	SETTORE FRONTALE / OVER FRONT / SUR L'AVANT / NACH VORNE ± 3°				SU 360° / OVER 360° / SUR 360° / BEI 360°				SETTORE FRONTALE / OVER FRONT / SUR L'AVANT / NACH VORNE ± 3°						
	8,05 m	10,70 m	13,40 m	16,10 m	8,05 m	10,70 m	13,40 m	8,05 m	10,70 m	13,40 m					
															
DIN	DIN	DIN	DIN	DIN	DIN	DIN	DIN	DIN	DIN	DIN					
3	16,60				10,25			13,75			3				
3,5	14,00				8,80			12,30			3,5				
4	11,40	11,40			7,40	7,40		10,90	10,90		4				
4,5	9,65	9,65			6,10	6,10		9,25	9,25		4,5				
5	7,95	7,95	7,95		4,80	4,80	4,80	7,60	7,60	7,60	5				
6		5,70	5,70	5,70		3,70	3,70		5,70	5,70	6				
7		4,75	4,75	4,75		2,75	2,75		4,75	4,75	7				
8			3,50	3,50			2,00			3,40	8				
9			2,90	2,90			1,50			2,85	9				
10			2,25	2,25						2,15	10				
12				1,40							12				
14				1,00							14				
16											16				

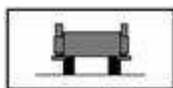

Portate su pneumatici  
Free on wheels  
Charges sur pneus  
Auf Reifen

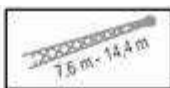

Prolunghe 7,6 m - 14,4 m  
7,6 m - 14,4 m extension  
Extension 7,6 m - 14,4 m  
Verlängerung 7,6 m - 14,4 m

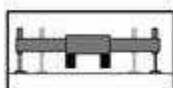

Stabilizzatori compl. estesi  
Outriggers fully extended  
Stabilisateurs en extension totale  
Abstützungen voll ausgefahren

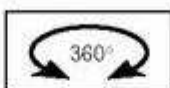

Rotazione su 360°  
Over 360° slewing  
Rotation sur 360°  
Schwenkbereich 360°

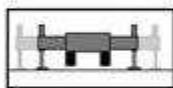

Stabilizzatori parz. estesi  
Outriggers half-extended  
Stabilisateurs en extension partielle  
Abstützungen halb ausgefahren



Settore frontale  
Over front  
Sur l'avant  
Nach vorne

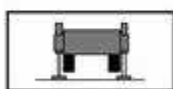

Stabilizzatori chiusi  
Outriggers unextended  
Stabilisateurs au ras du chassis  
Abstützungen nicht ausgefahren



Portata a norme CE (vedere note)  
The rated loads are in accordance with CE chart (see notes)  
Charges conformes à la réglementation CE (voir notes)  
Traglasten entsprechend E.G. Bestimmungen (Siehe Hinweise)

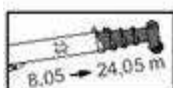

Braccio telescopico da 8,05 a 24,05 m  
Telescopic boom from 8,05 m to 24,05 m  
Flèche télescopique de 8,05 m à 24,05 m  
Hydraulischer Ausleger von 8,05 m bis 24,05 m

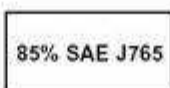

Portata a norme SAE 85% (vedere note)  
The rated loads are in accordance with SAE 85% chart (see notes)  
Charges conforme à la réglementation SAE 85%  
Traglasten entsprechend SAE Bestimmungen (Siehe Hinweise)

### Taglie di sollevamento / Hoist reeving / Mouflage / Hubrollen

N° di taglie / No. of line Nbr. de brins / Seilanzahl	1	2	3	4	5	6	7	8	9	10	11
Carico massimo in kN Max line pull in kN Charges maxi en kN Höchstlast in kN	38	76	114	152	190	228	266	304	342	380	418

Note	Notes	Notes	Hinweise
<p>I carichi indicati costituiscono i valori massimi coperti dalla garanzia del costruttore per utilizzo rispettivamente secondo le norme della Unione Europea (CE) o secondo la norma SAE J765. Sono espressi in tonnellate metriche ed includono il peso del bozzello, delle eventuali prolunghe applicate al braccio e di tutti gli accessori di sollevamento (brache, ecc.).</p> <p>Le operazioni di sollevamento nella configurazione su gomme devono essere effettuate su superficie piana e solida con la corretta pressione di gonfiaggio degli pneumatici e con l'oscillazione dell'assale posteriore bloccata qualora l'operazione non avvenga con braccio entro un settore di +/- 3° rispetto all'asse di mezzeria della autogrù.</p> <p>Le operazioni di traslazione con carico possono avvenire esclusivamente con braccio allineato all'asse di mezzeria della autogrù, perno di bloccaggio meccanico della rotazione della sovrastruttura inserito e avendo cura di mantenere il carico stesso in prossimità della autogrù senza oscillazioni.</p>	<p>The indicated loads are the maximum covered by the manufacturer's warranty for a use which complies with current EU directives (CE) or SAE J765 standard. Weights are given in metric tons. They include the weight of the block, all extensions fitted to the boom and all lifting accessories (slings and so on).</p> <p>Crane on wheels: operate the crane on a steady flat surface when hoisting loads and inflate tyres at proper pressure value. Also stop rear axle swinging if the load cannot be lifted having the arm within a +/-3° sector to the crane centreline.</p> <p>The load can be travelled only if the boom is aligned with the crane centreline, the shaft for upper structure rotation stop is fitted and the load is kept close to the crane and is not swinging.</p>	<p>Les charges indiquées constituent les valeurs maximales couvertes par la garantie du fabricant pour une utilisation conforme aux normes de l'Union Européenne ou selon la norme SAE J765. Elles sont exprimées en tonnes métriques et comprennent le poids de la moufle, des éventuelles extensions appliquées à la flèche et de tous les accessoires de levage (élingues, etc.).</p> <p>Les opérations de levage dans la configuration sur pneus doivent être effectuées sur une surface plane et solide avec une pression de gonflage des pneus correcte et l'oscillation de l'essieu bloquée si l'opération n'a pas lieu avec la flèche située dans une zone de +/- 3° par rapport à l'axe de moitié du camion-grue.</p> <p>Les opérations de translation avec charge ne peuvent être effectuées qu'avec flèche alignée dans l'axe de moitié du camion-grue, goujon de blocage mécanique de la rotation de la structure du dessus enclenché et en prenant soin de maintenir la charge à proximité du camion-grue sans oscillations.</p>	<p>Die angegebenen Lasten sind die Grenzwerte, für welche die Herstellergarantie bei Einsatz gemäß den Normen der Europäischen Union (EU) oder nach der Norm SAE J765 gültig ist. Die Grenzwerte sind in Metertonnen ausgedrückt, das Gewicht des Blocks, eventueller am Ausleger angebrachter Verlängerungen und jeglicher Hebezubehörteile (Schlingen usw.) ist inbegriffen.</p> <p>Hebearbeiten mit bereiftem Kran müssen auf einer ebenen und festen Oberfläche erfolgen; die Reifen müssen richtig befüllt und die Hinterachse festgestellt sein, wenn der Ausleger außerhalb eines Bereichs von +/- 3° im Verhältnis zur Mittelachse des fahrbaren Krans gehoben wird. Transportarbeiten mit belastetem Ausleger sind ausschließlich erlaubt, wenn der Ausleger an der Mittelachse des Krans angereicht ist, der mechanische Verriegelungszapfen, der die Drehung des Oberwagens verhindert, eingerastet ist und die Last ohne zu schwingen in Nähe des Krans behalten wird.</p>



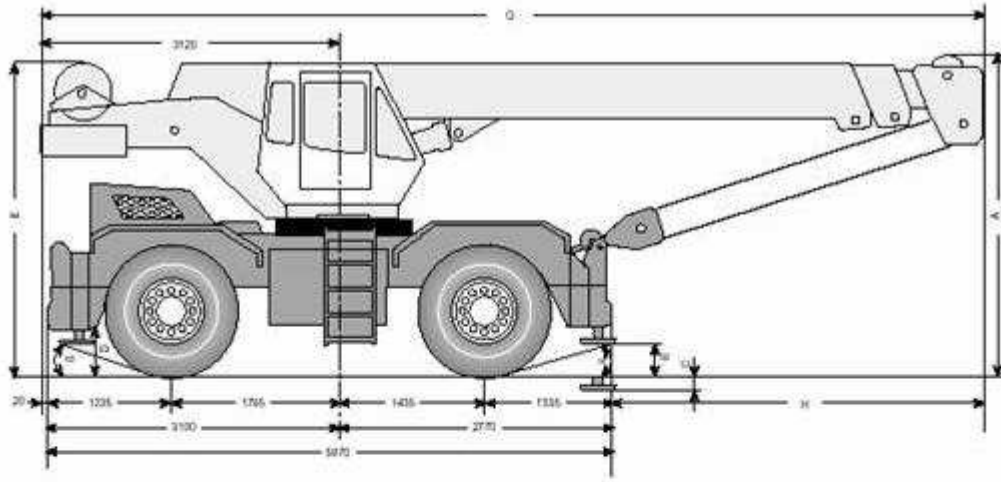

4 ruote sterzanti (quattro tra parentesi)  
 4 wheel steering ( numbers in brackets)  
 4 roues directrices (chiffres entre crochets)  
 bei Vierradlenkung (Angaben in Klammern)

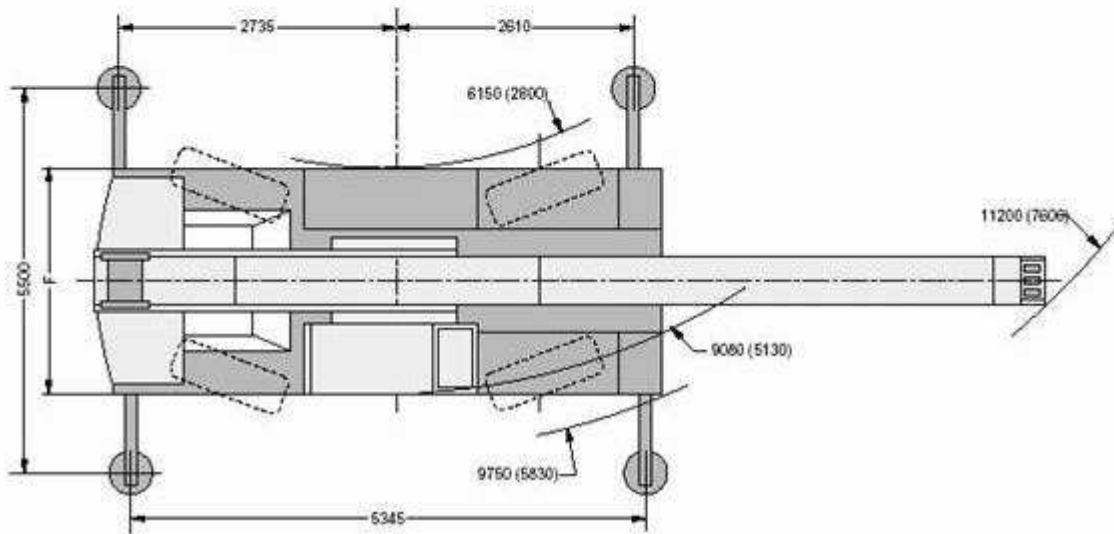

Dimensioni / Dimensions / Dimensions / Abmessungen <sup>(4)</sup>							
Pneumatici / Tyres Pneumatiques / Reifen	A	E	C	B	D	$\alpha$	$\beta$
14.00R24	3400	3200	150	360	500	21°	20°
16.00R25	3440	3240	190	400	540	21°	20°

(4) Dimensioni medie di riferimento fornite a puro titolo indicativo. Valori espressi in millimetri  
 (4) Average reference values, which are indicative only. Values are expressed in mm  
 (4) Dimensions moyennes de référence fournies à titre purement indicatif. Valeurs exprimées en millimètres  
 (4) Durchschnittsmaße; dienen ausschließlich als Richtwerte. Die Werte sind in Millimetern ausgedrückt

Note	Notes	Notes	Hinweise
Tutte le caratteristiche e le specifiche descritte possono essere soggette a variazioni senza preavviso. Tutti i dati riportati sono forniti a puro titolo informativo e non sono impegnativi dal momento che le prestazioni della macchina variano in funzione dell'utilizzo. La sola garanzia applicabile è quella fornita da TEREX Italia per i propri prodotti	All specifications and features herein described can be changed without prior advice. All indicated data are indicative only and are not binding as crane performs differently depending on its use. Only the warranty terms granted by TEREX Italia for their products can be applied.	Toutes les caractéristiques et spécifications décrites peuvent être sujettes à variations sans préavis. Toutes les données indiquées sont fournies à titre purement indicatif et n'engage pas la responsabilité du fabricant dans la mesure où les performances de la machine varient en fonction de l'utilisation. La seule garantie applicable est celle fournie par TEREX Italia pour ses propres produits.	Unangekündigte Änderungen sämtlicher Eigenschaften und Daten sind möglich. Alle Angaben sind Richtwerte und nicht verbindlich, da die Leistungen der Vorrichtung von deren Einsatz abhängen. Die einzige gültige Garantie ist jene der Firma TEREX Italia für die von dieser hergestellten Produkte.



ISO 9001 - Cert. 115/1



**TEREX ITALIA**  
Via Cassoletta 76  
40056 CREPELLANO (BO) - ITALY  
tel.: (+39) 0516501011  
fax: (+39) 051734645  
e-mail: [terexitalia@terex.it](mailto:terexitalia@terex.it)  
[www.terex.it](http://www.terex.it)



Cod. xxxxx Rev. 0 del 09/02