



TEREX®

Utilities

CAPTAIN 3039 SERIES

DIGGER DERRICK

Terex® Telelect Digger Derricks are known throughout the industry. They come with a long history featuring quality and innovative design.

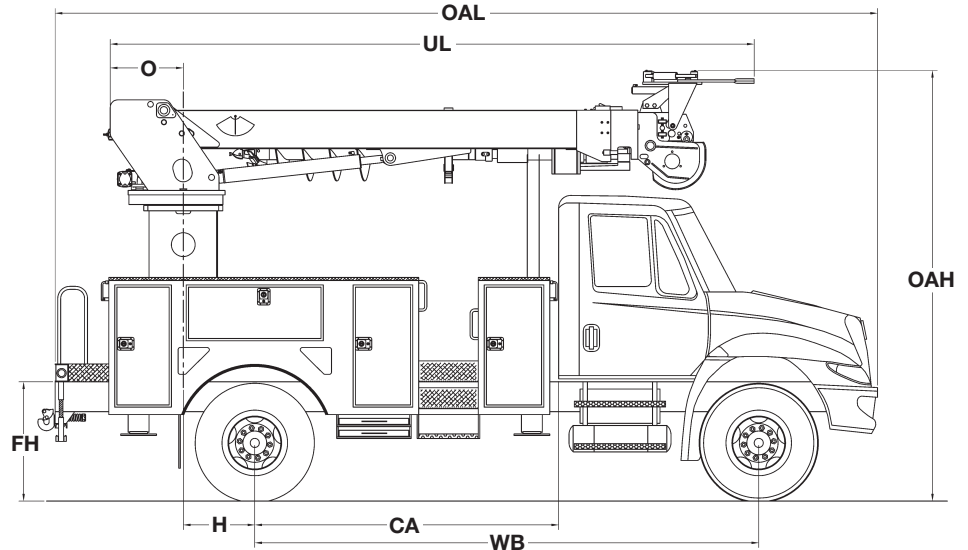

Measurements	Captain 3039
<i>(Minimum Recommendations)</i>	ORA
Frame Height (FH)	40 in. (101.6 cm)
Offset (O)	24.5 in. (62.2 cm)
Overall Height (OAH)	11' 10" (3.6 m)
Overall Length (OAL)	21' 11" (6.7 m)
Unit Length (UL)	18' 4" (5.6 m)
Center of Rotation (H)	24 in. (61 cm)
Cab to Axle (CA)	102 in. (259.1 cm)
Wheel Base (WB)	174 in. (442 cm)
Front Axle (GAWR)	7,000 lb. (3,175 kg)
Rear Axle (GAWR)	13,000 lb. (5,897 kg)
Gross Vehicle Weight Rating (GVWR)	19,000 lb. (8,618 kg)
Recommend Weight For Stability	19,000 lb. (8,618 kg)
Frame Section Modulus	18.0 in ³
Frame Yield Strength	50,000 psi
Frame RBM	900,000 in-lbs



TEREX® Utilities

500 Oakwood Drive
PO BOX 1150
Watertown, SD 57201-6150
USA

Phone: (605) 882-4000
Facsimile: (605) 882-1842
www.terexutilities.com
E-mail: sales@terexutilities.com

Distributed By:

CAPTAIN 3039 SERIES

STANDARD EQUIPMENT

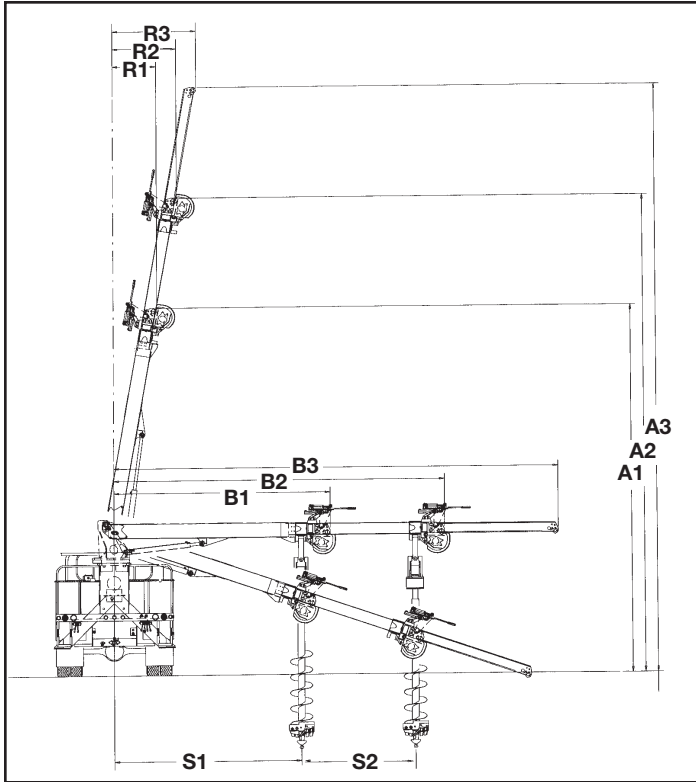

- 100 Degrees of Boom Travel (+80 to -20)
- 50 Gallon Hydraulic Oil Reservoir
- Boom Angle Indicator
- Boom Interlock
- Box Fabricated Steel Lower Boom and Intermediate
- Continuous Unrestricted Rotation
- Custom Made Zoned Load Chart
- Dual Handle Rack Controls
- Dual Lift Cylinders
- Fiberglass Hydraulic Upper Boom
- Full Pressure Hydraulic Controls
- Meets or Exceeds ANSI A10.31
- Open Center Hydraulic System
- Outrigger Moving Alarm
- Self-Aligning Swivel Ball Bushings
- Steel Hydraulic Intermediate

CAPACITIES & DIMENSIONAL DATA

Model	Maximum Capacity	Capacity @ 10 ft Radius	Load Radius			Sheave Height			Horizontal Reach			Digging Radius	
			R1	R2	R3	A1	A2	A3	B1	B2	B3	S1	S2
Captain 3039 TM Winch	24,719 lb (11,213 kg)	9,479 lb (4,300 kg)	2.7 ft (0.8 m)	4.0 ft (1.2 m)	5.4 ft (1.6 m)	25.3 ft (7.7 m)	32.7 ft (10.0 m)	40.0 ft (12.2 m)	15.0 ft (4.6 m)	22.5 ft (6.9 m)	30.0 ft (9.1 m)	12.3 ft (3.7 m)	19.8 ft (6.0 m)

OPTIONAL EQUIPMENT

- Diggers/Augers
- Fiberglass Personnel Platform
- Full Pressure Upper Controls
- Hydraulic Overload Protection (HOP)
- Material Handling Jibs
- Pole Puller
- Pole Guide
- Transferable Pole Buddy
- Various Types of Outriggers
- Auger Storage on Right Side
- Boom Tip Winch
- Command Post Operator Controls
- Hydraulic Tool Outlets at Upper Controls
- Multi-Part Line Components
- Planetary Slip Brake Rotation
- Radio Remote Controls
- Single Stick "T" Control
- Start/Stop and Throttle Advance at Top Controls
- Steel Upper 3rd & 4th (*Not Available w/Transferable Pole Buddy*)
- Turntable Mounted Winch
- Various Types of Controls

Effective Date: March 1, 2007. Product specifications and prices are subject to change without notice or obligation. The photographs and/or drawings in this document are for illustrative purposes only. Refer to the appropriate Operator's Manual for instructions on the proper use of this equipment. Failure to follow the appropriate Operator's Manual when using our equipment or to otherwise act irresponsibly may result in serious injury or death. The only warranty applicable to our equipment is the standard written warranty applicable to the particular product and sale and Terex makes no other warranty, express or implied. Products and services listed may be trademarks, service marks or trade-names of Terex Corporation and/or its subsidiaries in the USA and other countries and all rights are reserved. "Terex" is a registered trademark of Terex Corporation in the USA and many other countries. Copyright 2007 Terex Corporation.