

COMEDIL

Gru a torre "City"

"City" Tower Crane • Grue à tour "City"

"City" Turmdrehkran • Grua torre "City"

GTS 451-3

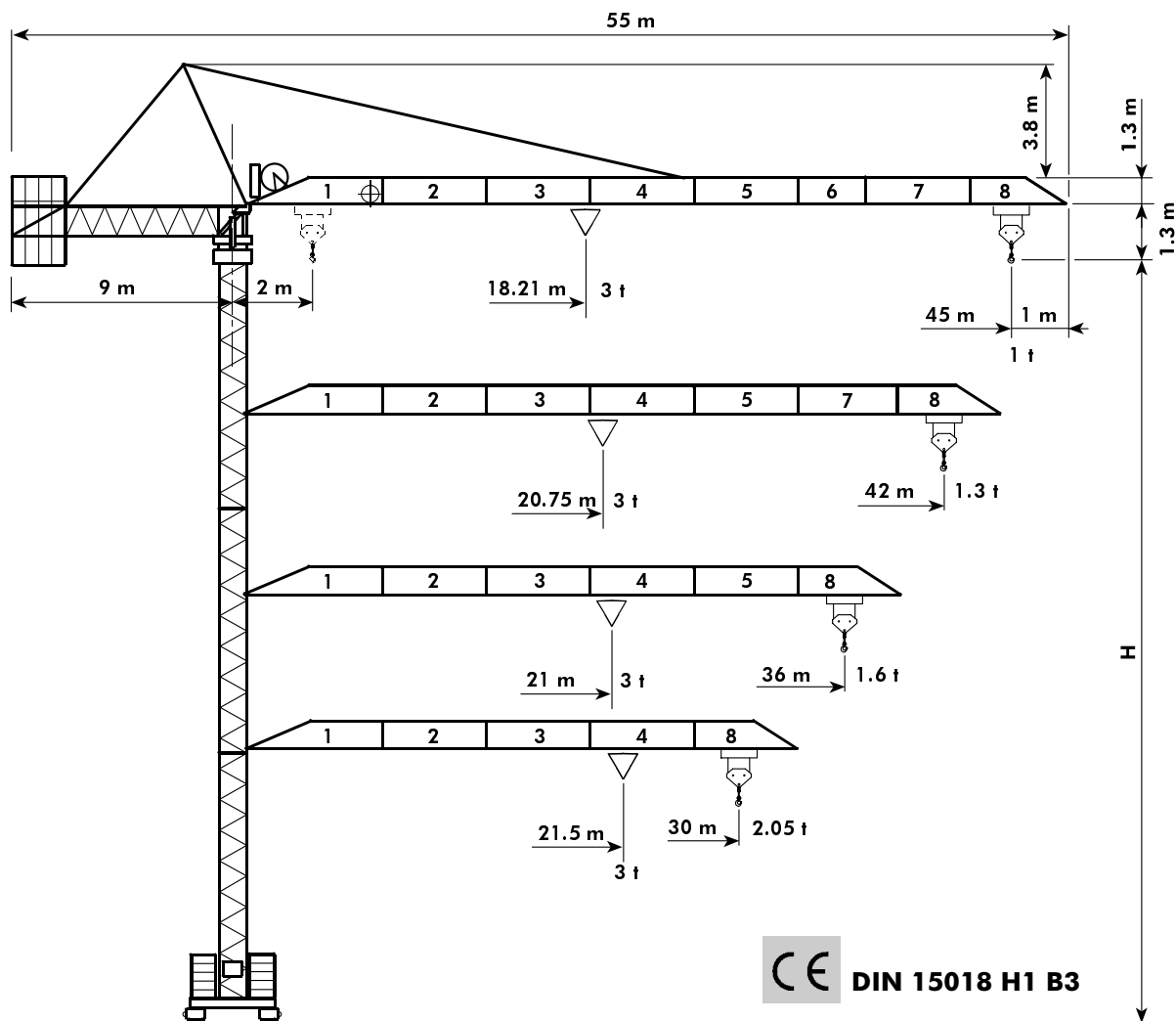

simple, available and cost effective™



Courtesy of Crane.Market

Diagramma di portata **I** **Curbes de charges** **F** **Curvas de cargas** **E**
Load Diagram **GB** **Lastkurven** **D**

GTS 451-3															
⚙	⚙	m	10	12	16	18	21	24	27	30	33	36	39	42	45
3 t - 18.21 m	t		3	3	3	3	2.55	2.19	1.9	1.68	1.49	1.34	1.2	1.09	1
3 t - 20.75 m	t		3	3	3	3	2.96	2.54	2.22	1.96	1.75	1.57	1.42	1.3	
3 t - 21 m	t		3	3	3	3	3	2.58	2.25	1.99	1.77	1.6			
3 t - 21.5 m	t		3	3	3	3	3	2.65	2.31	2.05					

Altre installazioni **I** **Autres implantations** **F** **Otras implantaciones** **E**
Other configurations **GB** **Aufstellmöglichkeiten** **D**

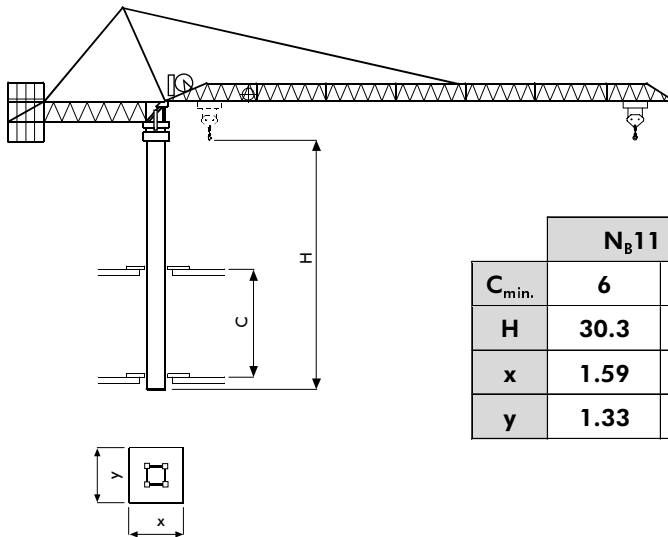

	N _B 11		S12	
C _{min.}	6	m	6.5	m
H	30.3	m	36.4	m
x	1.59	m	1.55	m
y	1.33	m	1.3	m

	"R"			
	N _B 11		S12	
A	~24	m	~30	m
B	~16	m	~18	m
C _{max}	~17	m	~25	m
H _{max}	~81.4	m	~134	m
H > H _{max}	i			

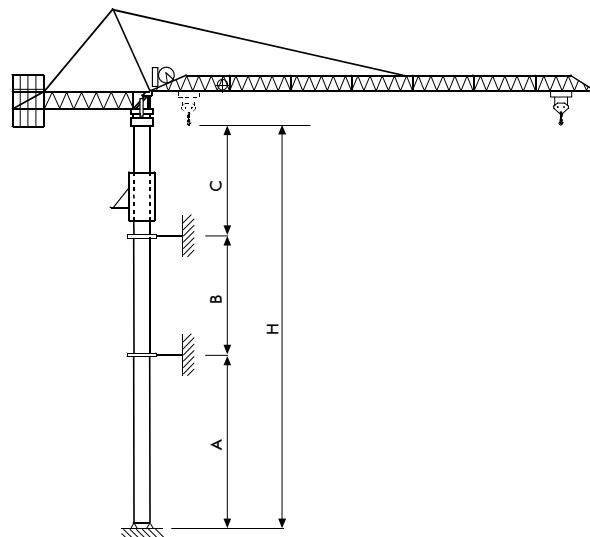

Torre Mast **I** **GB** Mât Turm **F** **D** Mástil **E**

Nb11

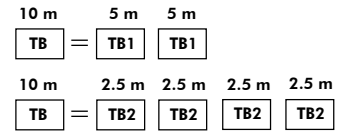
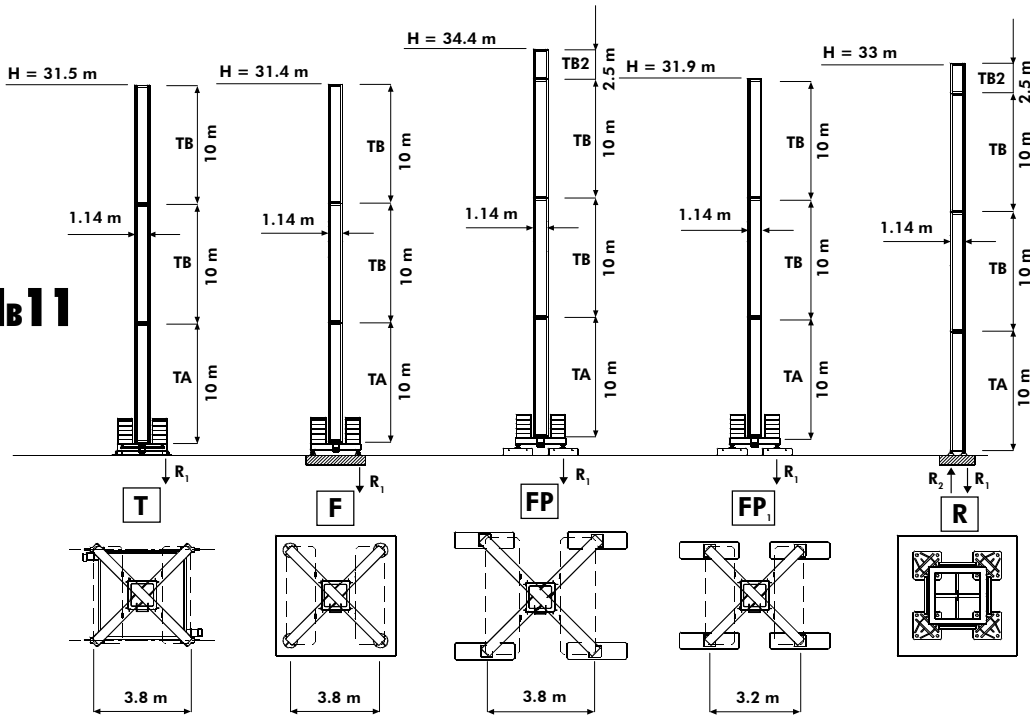

R ₁	695 kN ●	926 kN ◆
R ₂	521 kN ●	770 kN ◆
	18.8 t	

R ₁	392 kN ●	413 kN ◆	R ₁	382 kN ●	414 kN ◆	R ₁	413 kN ●	477 kN ◆	R ₁	447 kN ●	493 kN ◆
	22.5 t			22.5 t			23 t			21.3 t	

S12

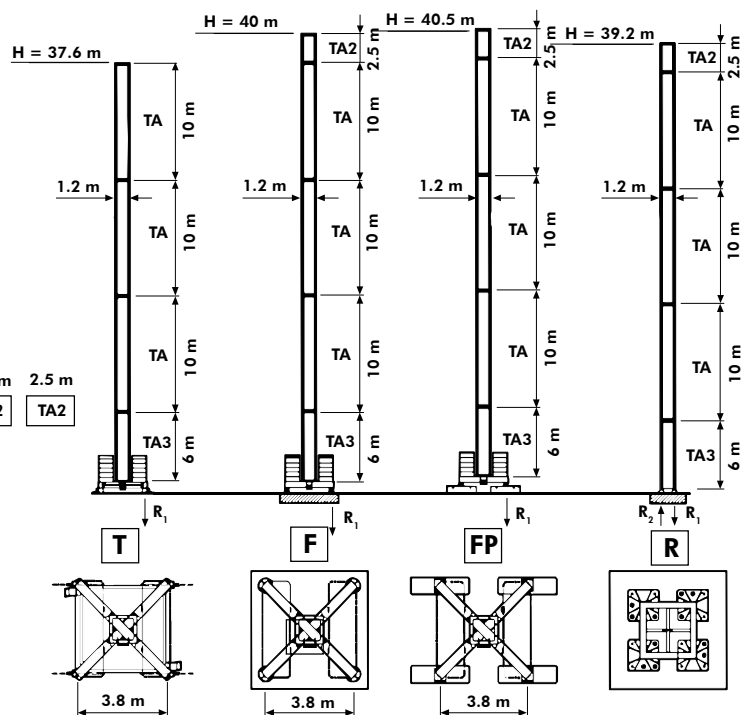
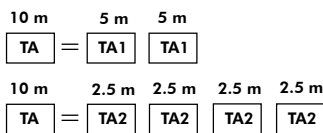

- H** Altezza massima sotto gancio **I**
- In servizio
- ◆ Fuori servizio
- A vuoto, senza zavorra, braccio max., altezza max.
- H** Max. under hook height **GB**
- In service
- ◆ Out of service
- Without load, without ballast, max. jib and max. height
- H** Hauteur maxi. sous crochet **F**
- En service
- ◆ Hors service
- A vide, sans lest, avec flèche et hauteur maximum
- H** Höchste Hackenhöhe **D**
- In Betrieb
- ◆ Außer Betrieb
- Ohne Last und Ballast, mit Maximalausleger und Maximalhöhe
- H** Maxima altura bajo gancho **E**
- En servicio
- ◆ Fuera de servicio
- Sin carga, sin lastre, con pluma y altura máxima

R ₁	747 kN ●	1162 kN ◆
R ₂	544 kN ●	985 kN ◆
	21 t	

R ₁	449 kN ●	512 kN ◆	R ₁	469 kN ●	577 kN ◆	R ₁	481 kN ●	593 kN ◆
	25 t			25 t			25 t	

Meccanismi
Mechanisms



I
GB

Mécanismes
Antriebe



F
D









Mecanismos

















E

	20 AG 30 HB 25 AG 30 HB	35 * kVA 40 * kVA	400 V - 50 Hz 400 V - 50 Hz / 460 V - 60 Hz	 87/405
--	----------------------------	----------------------	--	--

* Gru senza traslazione / Crane without travelling equipment / Grue sans translation / Krane ohne Schienenfahren / Grúa sin traslación

			m/min	t	kW	
	20 AG 30 HB (50 Hz)		6	3	15	196 m
			26	3		
			52	1.5		
	25 AG 30 HB		7	3	17.5	241 m (50 Hz) 196 m (60 Hz)
			32	3		
			63	1.5		

	DAD 2 2	0 - 23 - 46 m/min	1.1 - 2.2 kW
 	DSR 3 50	0 ⇨ 10 ⇨ 30 ⇨ 60 m/min	50 - 40 Nm
	SSR 11 50	0 ⇨ 0.8 r.p.m.	50 Nm
 	TAD 1 RP 2M3	0 - 24 m/min	2 x 3 kW
			

	Sollevamento	I	Levage	F	Elevación	E
	Traslazione carrello		Distribution		Distribución	
	Rotazione		Orientation		Orientación	
	Traslazione		Translation		Traslación	
	Direttiva sul livello acustico		Directive sur le niveau acoustique		Directiva sobre el nivel acustico	
	Consultateci		Nous consulter		Consultarnos	
	Potenza totale richiesta		Puissance totale nécessaire		Potencia necesaria	
	Alimentazione		Alimentation		Alimentación	
	Hoisting	GB	Heben	D		
	Trolleying		Katzfahren			
	Slewing		Schwenken			
	Travelling		Schienenfahren			
	Directive on noise level		Richtlinie für den Schall-Leistungspegel			
	Consult us		Auf Anfrage			
	Power requirements		Geforderte Stromstärke			
	Power supply		Stromversorgung			

AGENTE / DEALER / HÄNDLER / DISTRIBUTEUR / AGENTE