

REMIX RUBBER TIRE ASPHALT PAVER

**Features:**

- ▶ 10 ft (3.0 m) high-production mainline paver
- ▶ Patented Remix Anti-Segregation System
- ▶ Turbocharged 260 hp Tier 3 diesel engine
- ▶ Power-tilt hood with integral radiator
- ▶ Up to 30 ft (9.1 m) paving widths
- ▶ Patented Frame Raise System
- ▶ Patented Three-Point Suspension
- ▶ Fume-recovery system mitigates fumes

WORKS FOR YOU.™

SPECIFICATIONS

TRACTOR

All-welded mainframe construction
 24.5 x 32 in (622 x 813 mm) rear drive tires
 Oscillating front wheel bogie assemblies
 Two-wheel drive or front wheel assist
 Automatic hydraulic front wheel alignment
 Hydraulic power steering
 Differential lock
 Direct hydrostatic drive
 Three-Point suspension
 Adjustable spreading auger height via frame raise
 Oscillating push rollers or truck hitch
 Power tilt hood with integral radiator
 Fume-recovery system mitigates fumes
 Adjustable material retaining plates
 Operator's umbrella

SCREED

Screed assist (Stretch 20®)
 One-piece hardened steel screed plate
 Hydraulically adjustable screed vibrators
 Electric heat or oil heaters
 Manual and hydraulic power mat depth control
 Hydraulic power crown control
 Power match height adjustment
 (Stretch 20 and VersaScreed® 210)
 Vertically adjustable screed end gates
 Hydraulic screed lift with mechanical screed lock

FEED SYSTEM

Reinforced, sealed, tilting hopper wings with beveled corners
 Twin counter-rotating variable pitch Remix augers with one-piece shafts
 Independently controlled right and left feed systems
 Independently controlled delivery and spreading augers
 System interlocks stop feed when paver stops

CONTROLS

Operator swing console with spring loaded center lock and variable position cam lock
 Full instrumentation gauges
 Electric-over-hydraulic propel control steering wheel with dial-in working speed
 Lockout/tagout capable E-stop and master electrical switch



HYDRAULIC SYSTEM

Engine-mounted, enclosed, Poly Chain® belt pump drive
 Variable-displacement pumps for tractor drives, right and left feed systems and auxiliary circuits
 Fixed-displacement pump for vibrator circuit with flow control valve for frequency adjustment
 Centralized filter locations
 Remote-control solenoids with function-check LED
 Front gearbox Remix auger drive

PAVER

Paver width	10 ft 4 in (3.15 m)
Paving width (std)	10 ft (3.05 m)
Paving width (max)	30 ft (9.1 m)
Paving depth (max)	12 in (305 mm)
Paving speed (max)	290 ft/min (88 m/min)
Travel speed (max)	11.2 mph (18 km/hr)
Drive tires 12-ply	24.5 x 32 in (622 x 813 mm)
Front wheels	16 in wide x 22 in dia (406 x 559 mm)
Brakes hydrostatic steering; multiple disc parking	

WEIGHT*

Tractor	36,200 lbs (16,420 kg)
with Fastach® 10 and hydroflated tires	40,200 lbs (18,234 kg)
with VersaScreed 210 and hydroflated tires	42,200 lbs (19,142 kg)
with Stretch 20 and hydroflated tires	44,100 lbs (20,003 kg)

*Weights are based on average shipping weights.

ENGINE

Make/ Model	Cummins QSB6.7
Type	Tier 3 turbocharged diesel
Horsepower	260 hp (194 kW) @ 2200 rpm
Electrical	105 amp, 12 vdc



DIMENSIONAL INFORMATION:

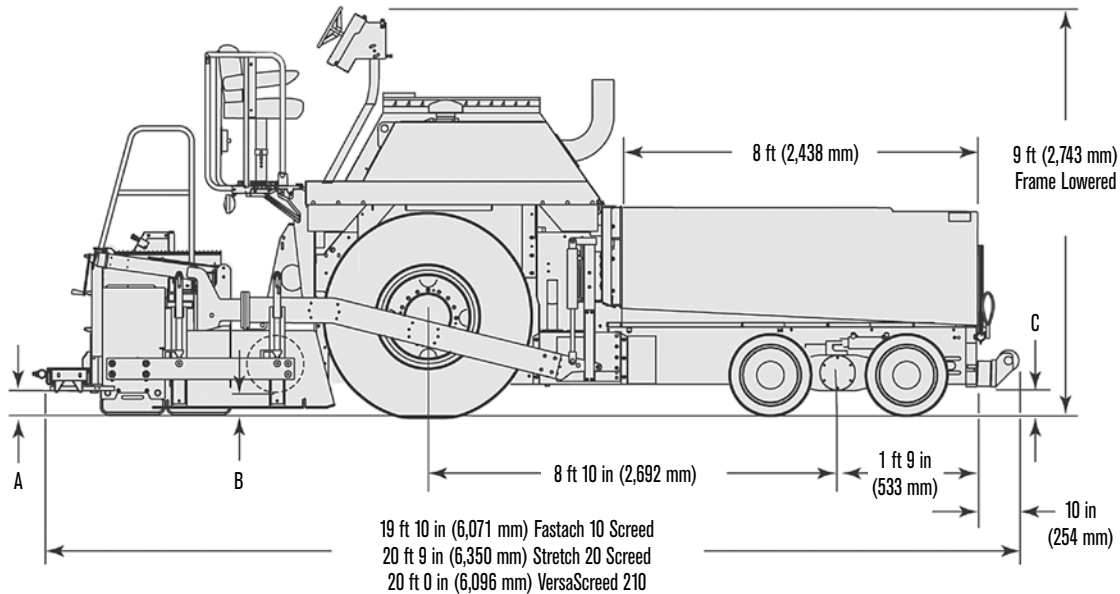

	A	B		C
	Screed Clearance	Auger Clearance Screed Up	Auger Clearance Screed Down	Frame Clearance
Frame Raised	15 1/2 in (394 mm)	9 in (229 mm)	9 1/2 in (241 mm)	6 1/2 in (165 mm)
Frame Lowered	9 in (229 mm)	3 in (76 mm)	5 in (127 mm)	8 in (203 mm)

CAPACITIES

Diesel fuel	72 gal (273 L)
Hydraulic oil	75 gal (284 L)
Cooling system	6.5 gal (25 L)

SPREADING AUGER SECTIONS

Construction	Cast, high alloy
Diameter	16 in (406 mm)
Thickness	5/8 in (16 mm)

HOPPER

Length & width	8 ft 2 in x 10 ft 4 in (2,489 x 3,150 mm)
Volume	267 ft ³ (7.56 m ³)
Capacity	16.7 tons (15 tonnes)
Feed tunnel width (each)	30 in (762 mm)
Remix augers (diameter)	12 in (305 mm)
Auger thickness	5/8 in (16 mm)
Trough liner thickness	3/8 in (9.5 mm)

SCREED

Screed plate	34 in x 10 ft (864 x 3,048 mm)
Thickness	1/2 in (12.7 mm)
Positive crown (hydraulically powered)	3 in (76 mm)
Negative crown (hydraulically powered)	1 in (25 mm)
Vibrations per minute (max)	3,000
Heaters	
Fastach 10 (two oil heaters)	178,000 BTU (total) 1.3 gph (4.9 liters/hr)
VersaScreed 210 (electric heat)	34 kW generator
Stretch 20 (four oil heaters)	274,000 BTU (total) 2.0 gph (7.6 liters/hr)
Stretch 20 (electric heat)	34 kW generator

OPTIONAL EQUIPMENT

Stretch 20 screed with electric or oil heat
VersaScreed 210 with electric heat
Fastach® 10 screed with electric or oil heat
Generation 4 proportional or sonic material feed control
Mechanical or sonic grade and slope control
Multi-foot grade reference system
Sonic averaging system
Proportional steer assist
Material feed package
Bevel guide plates
Cutoff shoes, 12 in (305 mm) and 24 in (610 mm) sections
30 ft (9,144 mm) hose reel for spray-down
Additional umbrella
500-hour filter kit

WORKS FOR YOU.™

www.terexrb.com

Effective Date: December, 2010. Product specifications and prices are subject to change without notice or obligation. The photographs and/or drawings in this document are for illustrative purposes only. Refer to the appropriate Operator's Manual for instructions on the proper use of this equipment. Failure to follow the appropriate Operator's Manual when using our equipment or to otherwise act irresponsibly may result in serious injury or death. The only warranty applicable to our equipment is the standard written warranty applicable to the particular product and sale and Terex makes no other warranty, express or implied. Products and services listed may be trademarks, service marks or trade-names of Terex Corporation and/or its subsidiaries in the USA and other countries. All rights are reserved. Terex is a registered trademark of Terex Corporation in the USA and many other countries. Copyright 2010 Terex Corporation.

Terex Roadbuilding P.O. Box 1985, Oklahoma City, OK 73101
(405) 787.6020 1-888-TEREXRB www.terexrb.com

