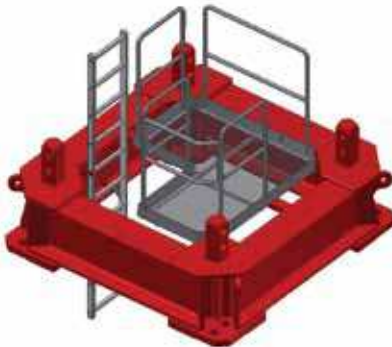
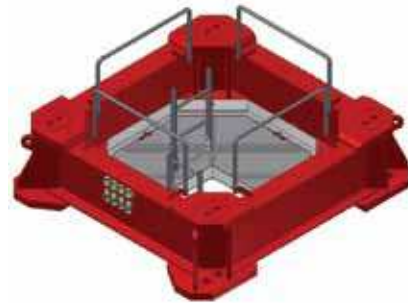

TRANSFER THE POSSIBILITIES

**HD23-TS212****HD23-TS23****TS23-H20****TS23-TS21**

Terex® Transfer Masts let you do more with less. Connect any two tower crane systems from Terex and/or our legacy brands, Peiner and Comedil, to form a new versatile and productive tower crane system – and you'll gain the benefits of both systems and more. It truly is a case of the whole being greater than the sum of the parts.

The four models shown here are the latest additions to the full Terex® Transfer Mast line, giving you even more choices to meet your exact needs.

- ▶ Improved freestanding capabilities
- ▶ Reduced assembly time – no need for anchoring collars
- ▶ Wide range of combinations using varying tower sections and upper parts help meet the exact needs of the job
- ▶ Higher return on investment through improved utilization of existing tower system sections in inventory

WORKS FOR YOU.™

The Possibilities Are Almost Endless

Because Terex® transfer masts let you combine Flat Top, Luffing Jib and Hammerhead tower cranes, you'll have more flexibility at the job site. Transfer masts can be positioned between two different tower elements or directly on the lower turntable. Connect any two tower systems from Terex and/or our legacy brands, Peiner and Comedil, to form one element to gain the benefits of both systems.



HD23-TS212 tower combination with the transfer mast positioned between the two systems. This is done to increase freestanding capabilities.



Here the transfer mast is positioned between the TS212 tower and the HD slewing unit.

EXAMPLE ▶ Hammerhead SK 415-20; Transfer Mast: HD23-TS212: Foundation Anchors

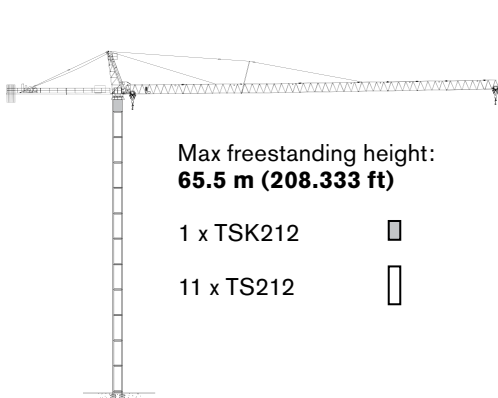

Max freestanding height:
65.5 m (208.333 ft)

- 1 x TSK212
- 11 x TS212

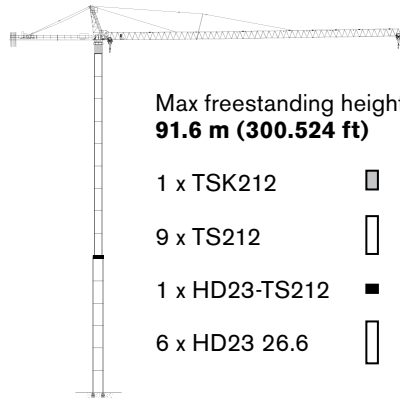

Max freestanding height:
91.6 m (300.524 ft)

- 1 x TSK212
- 9 x TS212
- 1 x HD23-TS212
- 6 x HD23 26.6

EXAMPLE ▶ Flat Top CTT 181B-8; Transfer Mast: HD23-TS21: Foundation Anchors

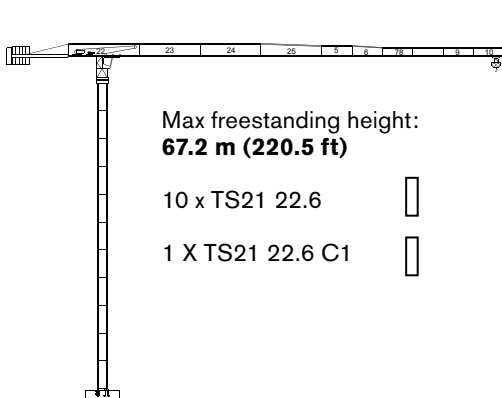

Max freestanding height:
67.2 m (220.5 ft)

- 10 x TS21 22.6
- 1 X TS21 22.6 C1

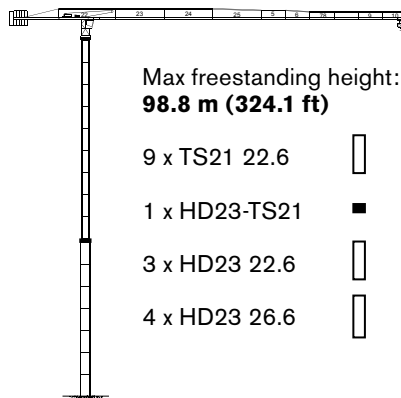

Max freestanding height:
98.8 m (324.1 ft)

- 9 x TS21 22.6
- 1 x HD23-TS21
- 3 x HD23 22.6
- 4 x HD23 26.6

www.terexcranes.com

Effective Date: December 2010. Product specifications and prices are subject to change without notice or obligation. The photographs and/or drawings in this document are for illustrative purposes only. Refer to the appropriate Operator's Manual for instructions on the proper use of this equipment. Failure to follow the appropriate Operator's Manual when using our equipment or to otherwise act irresponsibly may result in serious injury or death. The only warranty applicable to our equipment is the standard written warranty applicable to the particular product and sale. Terex makes no other warranty, express or implied. Products and services listed may be trademarks, service marks or trade-names of Terex Corporation and/or its subsidiaries in the USA and other countries. All rights are reserved. Terex is a registered trademark of Terex Corporation in the USA and many other countries. © 2010 Terex Corporation. XXXXXX-12/10



Terex Cranes, Global Marketing, Dinglerstraße 24, 66482 Zweibrücken, Germany
Tel. +49 (0) 6332 830, Email: info.cranes@terex.com, www.terexcranes.com