

AC 350

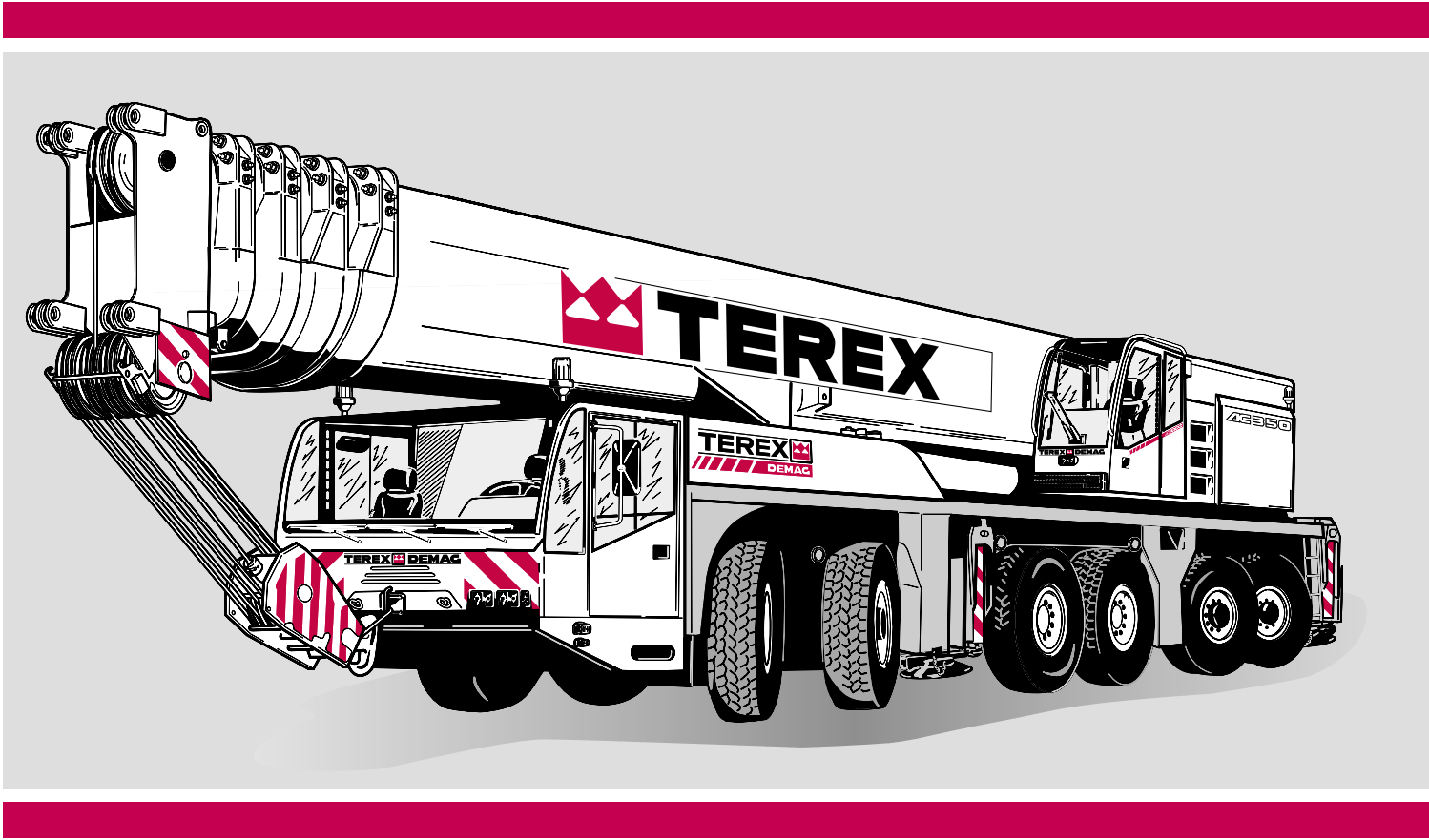

Demag AC 350

- ▶ Max. load capacity 400 t
- ▶ Sideways Superlift (SSL) for enormous capacity enhancements
- ▶ Unmatched maximum boom lengths of 413.3 ft through the combination of main boom and luffing fly jib
- ▶ Most compact 6-axle crane in its class with an overall length of just 54.8 ft

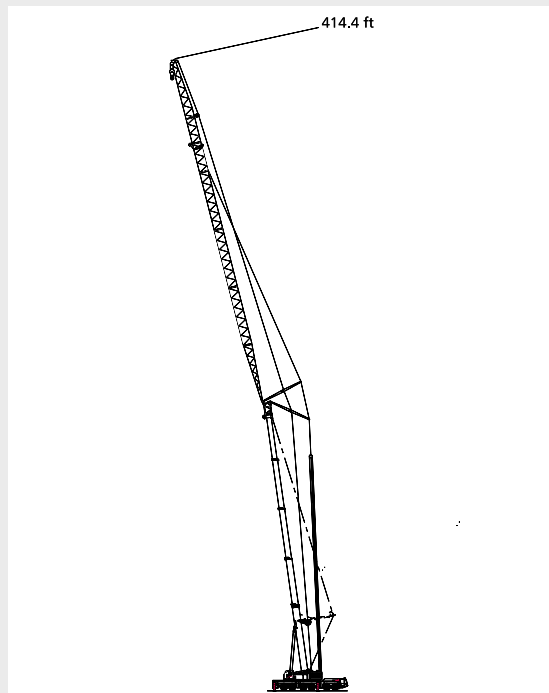
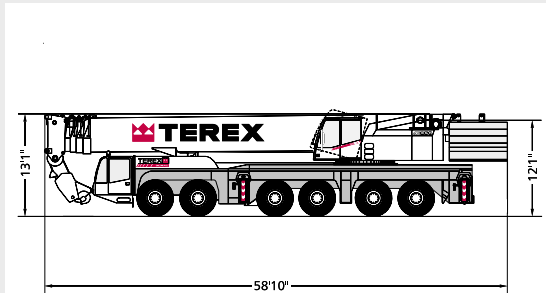
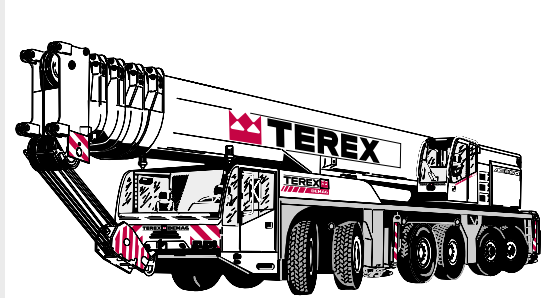

WWW. terex-cranes.com

Contents

	Page:	
Technical data		1
Dimensions	4	
Specifications	6	
Main boom		2
Working ranges with / without SSL	7	
Lifting capacities	8	
Lifting capacities with SSL	11	
Main boom extension		3
Working ranges with / without SSL	13	
Lifting capacities	14	
Lifting capacities with SSL 30°	16	
Fixed fly jib		4
Working ranges with / without SSL (LF)	18	
Lifting capacities (LF)	19	
Lifting capacities with SSL 30° (LF)	20	
Working ranges (SF) with / without SSL	21	
Lifting capacities (SF)	22	
Lifting capacities with SSL (SF)	24	
Luffing fly jib		5
Working ranges with / without SSL	25	
Lifting capacities	26	
Lifting capacities with SSL 60°	30	
Technical description		6
Carrier · Superstructure · Optional equipment	31	

Dimensions

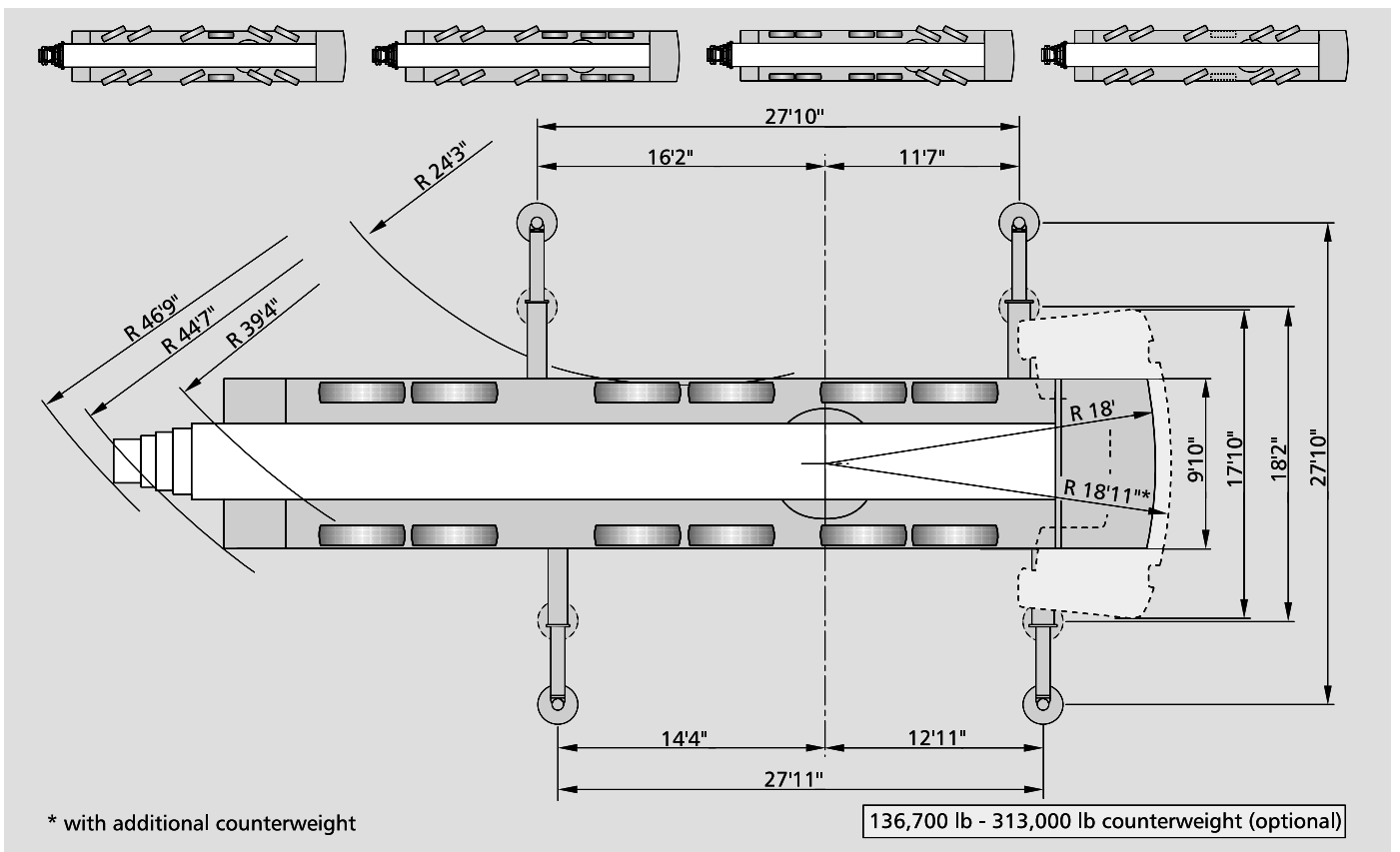
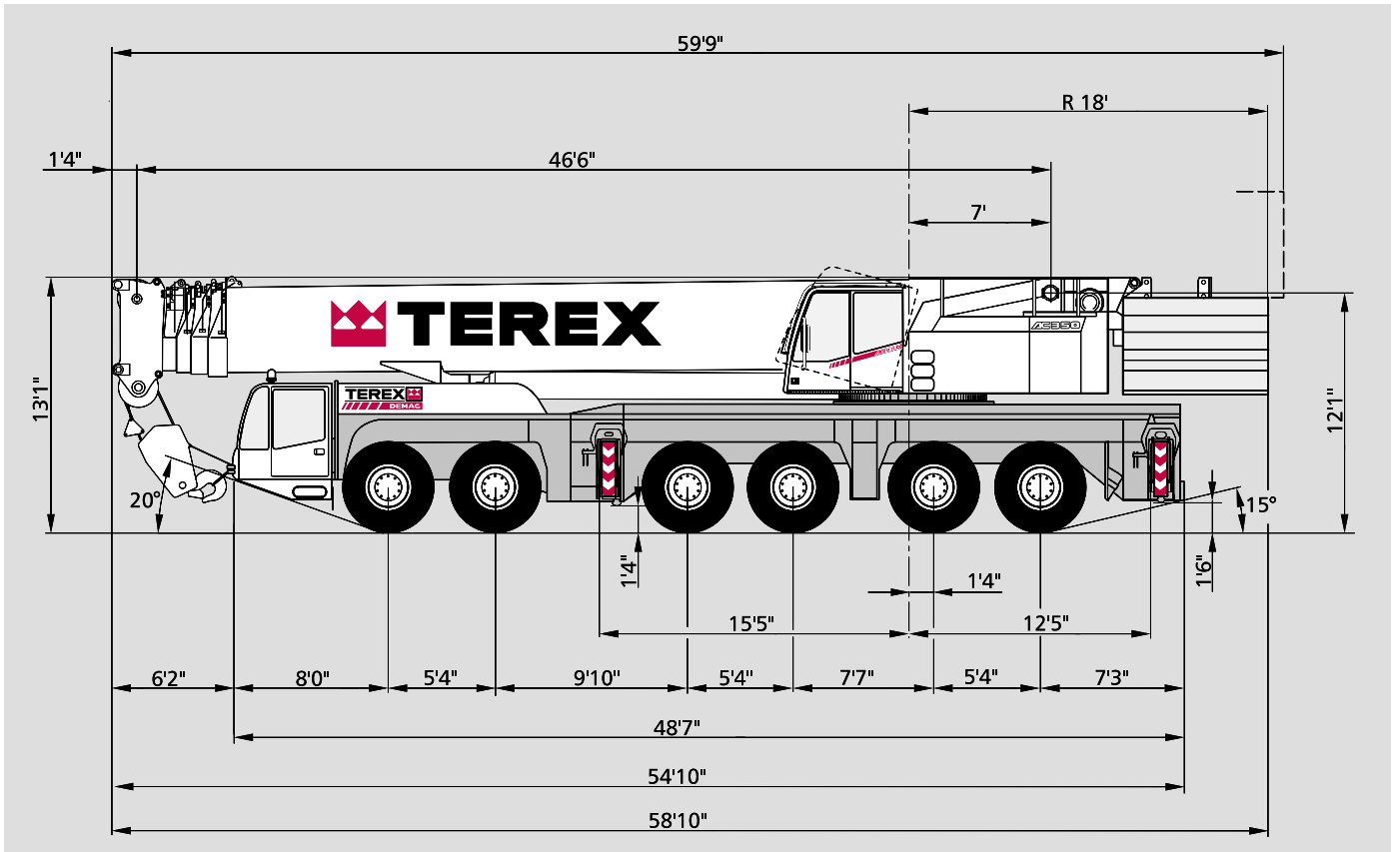

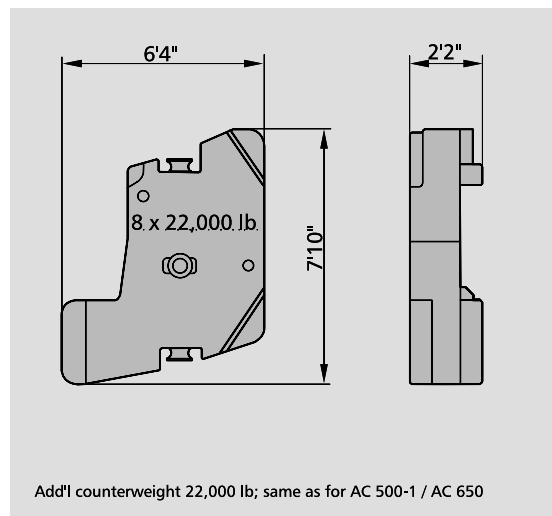
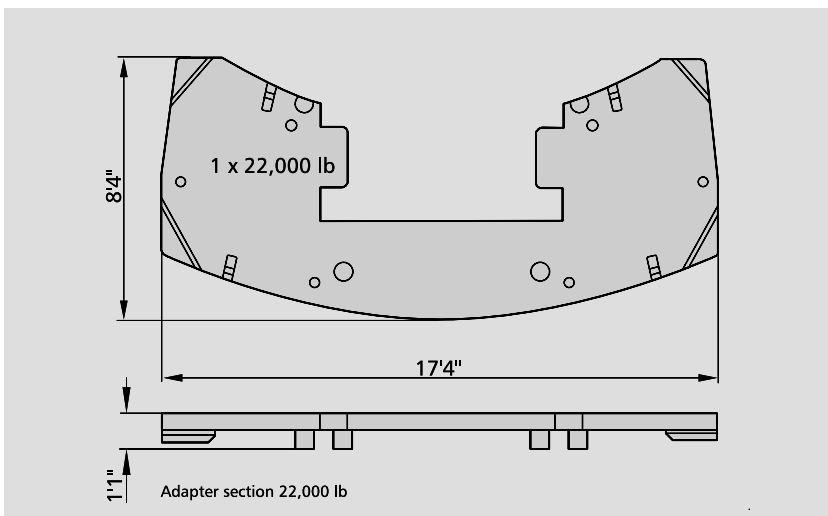
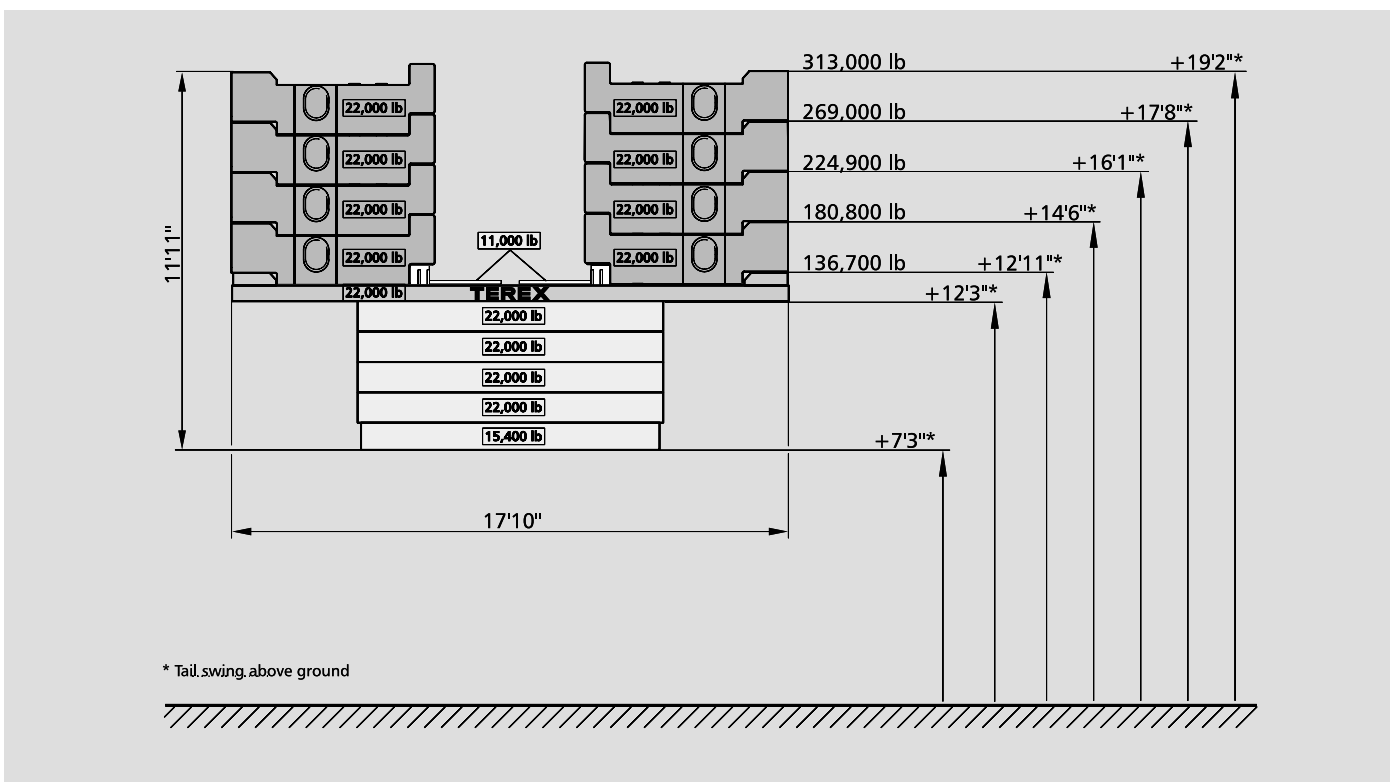
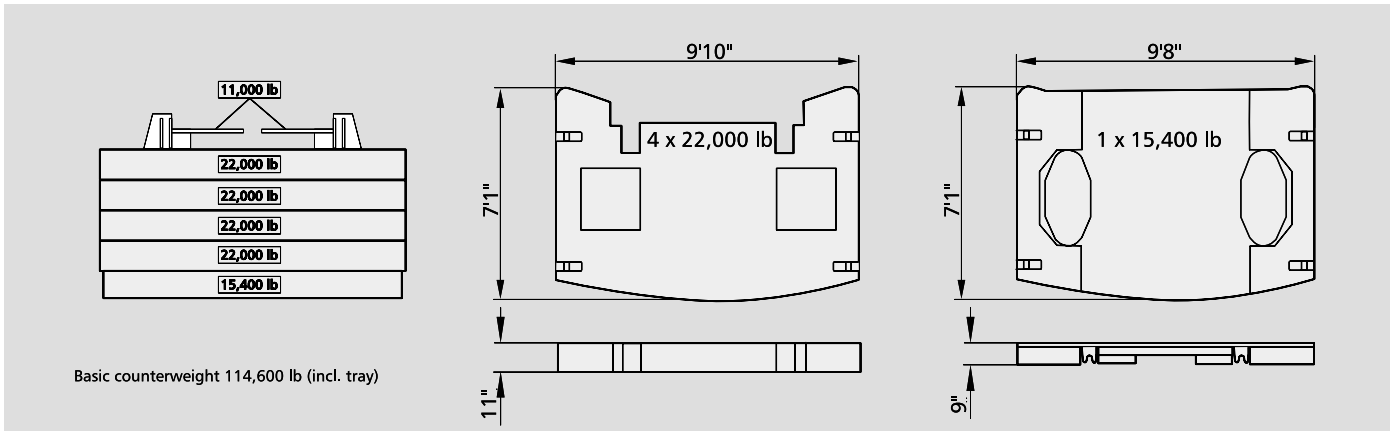

Specifications

Axle loads

Crane in travel order	
Axles	6 x 26,455 lb
Total weight	158,730 lb

Working speeds (infinitely variable)

Mechanisms	Normal speed	High speed	Max. permissible line pull	Rope diameter / Rope length
Hoist I	197 ft / min	476 ft / min	115 kN	0.91' / 1,230 ft
Hoist II	197 ft / min	508 ft / min	115 kN	0.91' / 1,857 ft
Slewing				max. 1.1 1/min
Telescoping speed				46.6 – 183.7 ft: 420 s
Boom elevation				-1,6° – +82°: 85 s

Carrier performance

Travel speed	0 .. 53 mph
Gradability	41 %
Ground clearance	1.34 ft

Hook block / Heavy-lift attachment

Type	Possible load	Number of sheaves	Weight	„D“	max. reeving	Heavy-lift attachment
250	523,6 klb	11	4,400 lb	9.8 ft	23	6 add'l sheaves
200/9	441,0 klb	9	4,400 lb	9.8 ft	19	6 add'l sheaves
200/7	355,0 klb	7	3,750 lb	9.8 ft	15	2 add'l sheaves
125	265,0 klb	5	2,645 lb	9.8 ft	11	
80	172,0 klb	3	2,315 lb	9.8 ft	7	
40	75,0 klb	1	2,315 lb	8.6 ft	3	
12,5	25,3 klb	Single line hook	1,100 lb	6.6 ft	1	

Working ranges main boom with / without SSL

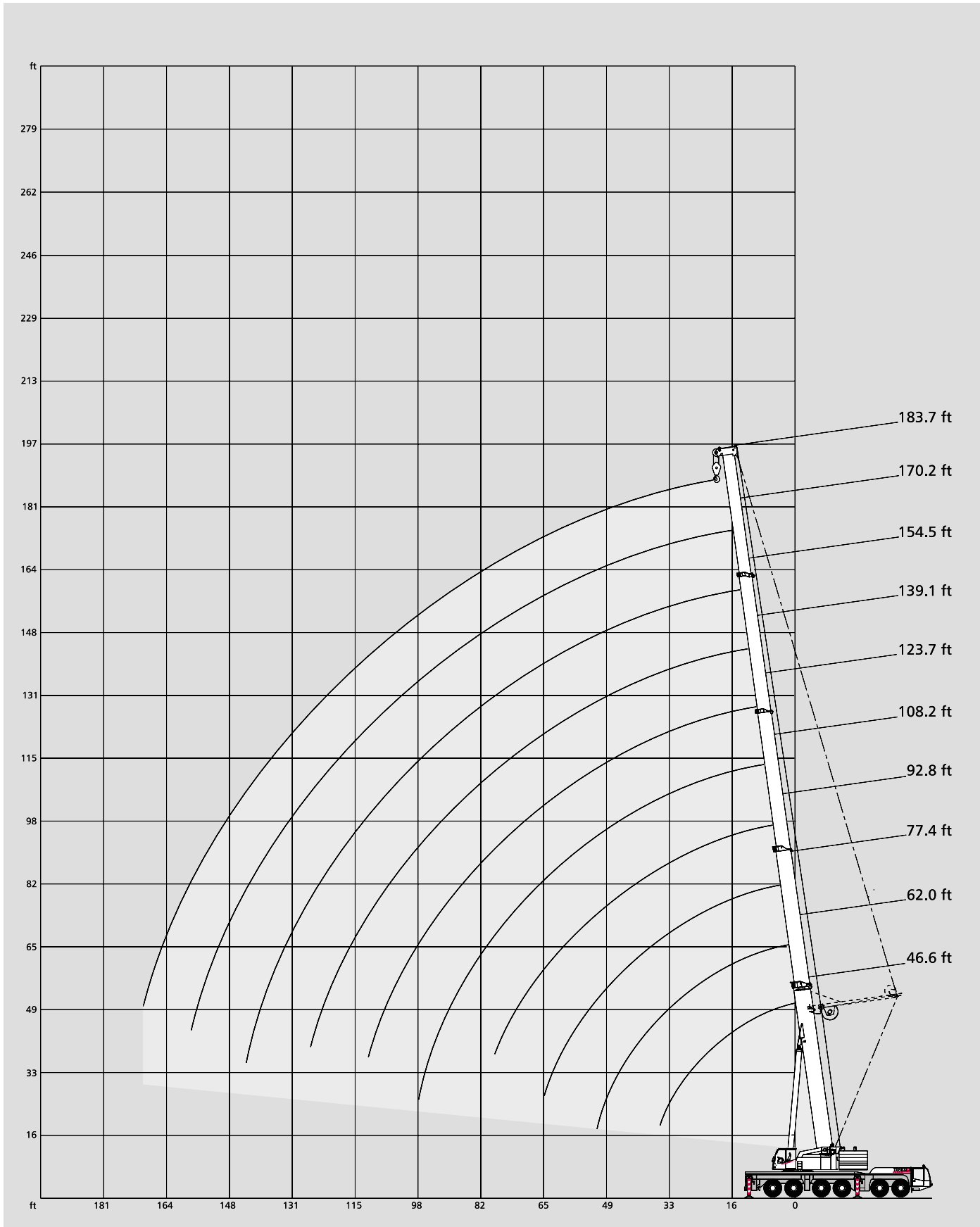

Lifting capacities main boom

313,100 lb   360°  85%

		Main boom											
Radius	ft	46.6	62.0	77.4	92.9	108.3	123.7	139.1	154.5	170.3	183.7	Radius	ft
		1,000 lb											
19		358.3*	358.3*	329.0*	277.4	235.0	-	-	-	-	-	19	
23		312.7*	312.7*	312.7*	266.6	226.9	182.9	154.2	-	-	-	23	
26		284.5*	284.5*	284.5*	254.5	216.8	176.8	148.2	128.2	-	-	26	
29		261.8	261.1	261.8	244.2	206.8	168.9	142.1	124.1	108.6	-	29	
33		233.0	234.9	234.8	228.5	193.3	158.2	134.1	118.7	103.8	88.0	33	
39		-	204.8	202.6	204.3	173.2	142.0	124.0	110.7	96.9	83.1	39	
46		-	173.6	171.7	173.9	151.9	123.3	110.1	101.5	89.4	77.5	46	
52		-	129.3	151.5	151.7	137.8	111.2	100.4	93.8	83.3	72.9	52	
59		-	-	130.2	132.4	123.5	98.6	90.2	85.3	76.7	67.7	59	
65		-	-	107.4	118.3	113.4	89.3	82.9	78.7	71.7	63.4	65	
72		-	-	-	106.3	105.7	80.2	75.3	71.3	66.2	58.9	72	
79		-	-	-	85.4	97.5	72.5	68.7	65.0	61.5	54.7	79	
85		-	-	-	-	89.4	67.0	63.5	60.2	57.7	51.5	85	
92		-	-	-	-	74.7	61.6	57.8	55.0	53.5	48.2	92	
98		-	-	-	-	55.1	57.6	53.6	51.2	50.2	45.6	98	
105		-	-	-	-	-	53.1	49.3	47.6	46.7	42.7	105	
111		-	-	-	-	-	48.5	45.9	44.3	43.7	40.3	111	
118		-	-	-	-	-	-	42.6	41.4	40.6	37.9	118	
124		-	-	-	-	-	-	39.9	39.0	38.1	35.9	124	
131		-	-	-	-	-	-	-	36.4	35.5	33.8	131	
138		-	-	-	-	-	-	-	33.8	33.0	31.6	138	
144		-	-	-	-	-	-	-	-	31.1	30.0	144	
151		-	-	-	-	-	-	-	-	29.3	28.4	151	
157		-	-	-	-	-	-	-	-	-	26.8	157	
164		-	-	-	-	-	-	-	-	-	25.1	164	

269,000 lb   360°  85%

		Main boom												
Radius	ft	46.6 ¹⁾	46.6	62.0	77.4	92.9	108.3	123.7	139.1	154.5	170.3	183.7	Radius	ft
		1,000 lb												
9.8		800.0*	-	-	-	-	-	-	-	-	-	-	9.8	
10		747.7*	518.9	385.5*	352.5*	-	-	-	-	-	-	-	10	
11		595.9*	496.0	384.2*	351.1*	-	-	-	-	-	-	-	11	
13		491.9*	452.4	379.5*	348.4*	286.5	-	-	-	-	-	-	13	
15		459.1*	414.7	373.8*	343.2*	286.2	-	-	-	-	-	-	15	
16		443.0*	397.2	369.8*	340.5*	284.9	241.1	-	-	-	-	-	16	
19		396.4*	355.3	348.9*	329.0*	277.4	235.0	190.9	-	-	-	-	19	
23		336.8*	308.3	306.1*	308.3*	266.6	226.9	182.9	154.2	-	-	-	23	
26		298.5*	280.1	279.9*	280.1*	254.5	216.8	176.8	148.2	128.2	-	-	26	
29		267.6*	257.4	257.4	257.4	244.2	206.8	168.9	142.1	124.1	108.6	-	29	
33		233.2*	228.9	230.4	230.3	228.2	193.3	158.2	134.1	118.7	103.8	88.0	33	
39		-	-	196.2	196.0	196.0	173.2	142.0	124.0	110.7	96.9	83.1	39	
46		-	-	164.9	162.9	165.1	151.9	123.3	110.1	101.5	89.4	77.5	46	
52		-	-	128.6	142.7	144.9	137.8	111.2	100.4	93.8	83.3	72.9	52	
59		-	-	-	123.6	125.8	123.5	98.6	90.2	85.3	76.7	67.7	59	
65		-	-	-	107.4	111.6	113.4	89.3	82.9	78.7	71.7	63.4	65	
72		-	-	-	-	100.3	102.3	80.2	75.3	71.3	66.2	58.9	72	
79		-	-	-	-	85.6	91.5	72.5	68.7	65.0	61.5	54.7	79	
85		-	-	-	-	-	83.5	67.0	63.5	60.2	57.7	51.5	85	
92		-	-	-	-	-	74.7	61.6	57.8	55.0	53.5	48.2	92	
98		-	-	-	-	-	55.1	57.6	53.6	51.2	50.2	45.6	98	
105		-	-	-	-	-	-	53.1	49.3	47.6	46.7	42.7	105	
111		-	-	-	-	-	-	48.5	45.9	44.3	43.7	40.3	111	
118		-	-	-	-	-	-	-	42.6	41.4	40.6	37.9	118	
124		-	-	-	-	-	-	-	39.9	39.0	38.1	35.9	124	
131		-	-	-	-	-	-	-	-	36.4	35.5	33.8	131	
138		-	-	-	-	-	-	-	-	33.8	33.0	31.6	138	
144		-	-	-	-	-	-	-	-	-	31.1	30.0	144	
151		-	-	-	-	-	-	-	-	-	29.3	28.4	151	
157		-	-	-	-	-	-	-	-	-	-	26.8	157	
164		-	-	-	-	-	-	-	-	-	-	25.1	164	

Remarks

* with special attachment ¹⁾ only over rear

224,900 lb**360°****85 %**

Main boom

Radius	ft	46.6	62.0	77.4	92.9	108.3	123.7	139.1	154.5	170.3	183.7	Radius
ft						1,000 lb						ft
10		514.0*	385.5*	352.5*	-	-	-	-	-	-	-	10
11		488.5*	384.2*	351.1*	-	-	-	-	-	-	-	11
13		443.5*	379.5*	348.4*	286.5	-	-	-	-	-	-	13
15		408.1*	373.8*	343.2*	286.2	-	-	-	-	-	-	15
16		390.6*	369.8*	340.5*	284.9	241.1	-	-	-	-	-	16
19		348.7*	343.7*	329.0*	277.4	235.0	190.9	-	-	-	-	19
23		303.9*	301.7*	301.7*	266.6	226.9	182.9	154.2	-	-	-	23
26		275.7*	275.2*	275.5*	254.5	216.8	176.8	148.2	128.2	-	-	26
29		253.0	253.0	251.1	244.2	206.8	168.9	142.1	124.1	108.6	-	29
33		220.6	221.6	221.5	221.5	193.3	158.2	134.1	118.7	103.8	88.0	33
39		-	187.4	185.2	187.3	173.2	142.0	124.0	110.7	96.9	83.1	39
46		-	156.2	154.1	156.3	151.9	123.3	110.1	101.5	89.4	77.5	46
52		-	127.9	135.8	136.1	137.8	111.2	100.4	93.8	83.3	72.9	52
59		-	-	119.1	116.9	119.2	98.6	90.2	85.3	76.7	67.7	59
65		-	-	106.4	104.0	106.6	89.3	82.9	78.7	71.7	63.4	65
72		-	-	-	89.4	92.0	80.2	75.3	71.3	66.2	58.9	72
79		-	-	-	78.0	80.3	72.5	68.7	65.0	61.5	54.7	79
85		-	-	-	-	72.0	67.0	63.5	60.2	57.7	51.5	85
92		-	-	-	-	64.1	61.6	57.8	55.0	53.5	48.2	92
98		-	-	-	-	54.4	56.5	53.6	51.2	50.2	45.6	98
105		-	-	-	-	-	51.1	49.3	47.6	46.7	42.7	105
111		-	-	-	-	-	48.5	45.9	44.3	43.7	40.3	111
118		-	-	-	-	-	-	42.1	41.4	40.6	37.9	118
124		-	-	-	-	-	-	38.7	39.0	38.1	35.9	124
131		-	-	-	-	-	-	-	36.0	35.5	33.8	131
138		-	-	-	-	-	-	-	32.7	33.0	31.6	138
144		-	-	-	-	-	-	-	-	31.1	30.0	144
151		-	-	-	-	-	-	-	-	29.0	28.4	151
157		-	-	-	-	-	-	-	-	-	26.8	157
164		-	-	-	-	-	-	-	-	-	24.9	164
170		-	-	-	-	-	-	-	-	-	-	170

2**136,700 lb****360°****85 %**

Main boom

Radius	ft	46.6	62.0	77.4	92.9	108.3	123.7	139.1	154.5	170.3	183.7	Radius
ft						1,000 lb						ft
10		496.6*	385.5*	352.5*	-	-	-	-	-	-	-	10
11		472.4*	384.2*	351.1*	-	-	-	-	-	-	-	11
13		430.1*	379.5*	348.4*	286.5	-	-	-	-	-	-	13
15		393.3*	373.8*	343.2*	286.2	-	-	-	-	-	-	15
16		378.5*	369.8*	340.5*	284.9	241.1	-	-	-	-	-	16
19		335.9*	335.0*	329.0*	277.4	235.0	190.9	-	-	-	-	19
23		286.2	286.2	286.2	266.6	226.9	182.9	154.2	-	-	-	23
26		253.9	253.9	251.9	252.4	216.8	176.8	148.2	128.2	-	-	26
29		225.4	225.4	223.2	225.4	206.8	168.9	142.1	124.1	108.6	-	29
33		192.8	194.9	195.0	194.9	190.6	158.2	134.1	118.7	103.8	88.0	33
39		-	154.6	158.7	154.6	154.3	142.0	124.0	110.7	96.9	83.1	39
46		-	123.2	121.0	123.2	121.0	116.6	110.0	101.5	89.4	77.5	46
52		-	103.4	100.4	103.4	100.8	98.9	97.1	93.8	83.3	72.9	52
59		-	-	84.5	85.2	82.6	81.4	80.8	80.7	76.7	67.7	59
65		-	-	74.4	73.5	70.8	71.9	69.3	70.3	70.3	63.4	65
72		-	-	-	62.6	59.8	61.1	58.0	59.1	60.8	58.9	72
79		-	-	-	53.6	51.1	53.3	52.9	53.3	51.9	52.4	79
85		-	-	-	-	45.0	47.6	47.8	47.4	45.9	46.1	85
92		-	-	-	-	39.1	42.2	42.2	41.3	39.8	40.0	92
98		-	-	-	-	35.1	39.6	38.8	37.1	35.5	35.7	98
105		-	-	-	-	-	35.7	34.8	33.0	31.3	31.5	105
111		-	-	-	-	-	32.2	31.4	29.4	27.8	28.0	111
118		-	-	-	-	-	-	28.2	26.2	24.5	24.7	118
124		-	-	-	-	-	-	25.6	23.4	21.7	21.9	124
131		-	-	-	-	-	-	-	21.0	19.2	19.4	131
138		-	-	-	-	-	-	-	18.4	16.7	16.9	138
144		-	-	-	-	-	-	-	-	15.0	15.3	144
151		-	-	-	-	-	-	-	-	13.2	13.2	151
157		-	-	-	-	-	-	-	-	-	11.7	157
164		-	-	-	-	-	-	-	-	-	10.3	164

AC 350

9

Courtesy of Crane Market

Lifting capacities main boom

92,600 lb



360°

85%

Main boom

Radius	ft	46.6	62.0	77.4	92.9	108.3	123.7	139.1	154.5	170.3	183.7	Radius
ft	1,000 lb											ft
10		488.0*	385.5*	352.5*	-	-	-	-	-	-	-	10
11		465.1*	384.2*	351.1*	-	-	-	-	-	-	-	11
13		421.5*	379.5*	348.4*	286.5	-	-	-	-	-	-	13
15		386.4*	372.8*	343.2*	286.2	-	-	-	-	-	-	15
16		370.2*	364.8*	340.5*	284.9	241.1	-	-	-	-	-	16
19		325.3*	323.1*	318.5*	277.4	235.0	190.9	-	-	-	-	19
23		266.3	266.3	264.1	248.6	226.7	182.9	154.2	-	-	-	23
26		230.0	232.1	223.7	210.3	200.5	176.8	148.2	128.2	-	-	26
29		203.0	203.3	200.4	181.3	174.3	161.5	142.1	124.1	108.6	-	29
33		161.8	161.8	166.2	159.9	148.9	138.0	129.2	118.4	103.8	88.0	33
39		-	126.9	124.4	127.6	118.7	110.4	104.2	100.3	96.9	83.1	39
46		-	97.2	98.7	97.6	93.4	90.8	82.3	82.5	79.2	76.8	46
52		-	78.4	79.8	78.7	81.1	78.3	74.8	72.0	67.1	65.3	52
59		-	-	64.6	66.4	65.3	63.1	65.1	60.2	55.8	54.5	59
65		-	-	56.0	56.5	55.4	55.6	55.2	52.4	48.3	47.2	65
72		-	-	-	47.6	46.3	46.9	46.0	44.0	41.1	40.3	72
79		-	-	-	40.5	39.4	39.9	39.2	37.2	35.2	34.6	79
85		-	-	-	-	34.6	35.0	34.4	32.4	30.6	30.4	85
92		-	-	-	-	30.1	30.3	29.6	27.4	25.7	26.1	92
98		-	-	-	-	28.2	26.9	26.0	24.0	22.2	22.5	98
105		-	-	-	-	-	23.8	22.9	20.7	18.9	19.1	105
111		-	-	-	-	-	20.9	20.1	17.8	16.1	16.3	111
118		-	-	-	-	-	-	17.4	15.4	13.7	13.9	118
124		-	-	-	-	-	-	15.4	13.2	11.4	11.7	124
131		-	-	-	-	-	-	-	11.3	9.5	9.7	131
138		-	-	-	-	-	-	-	9.4	7.6	7.8	138
144		-	-	-	-	-	-	-	-	6.4	6.4	144
151		-	-	-	-	-	-	-	-	5.0	5.0	151
157		-	-	-	-	-	-	-	-	-	4.0	157

48,500 lb



360°

85%

Main boom

Radius	ft	46.6	62.0	77.4	92.9	108.3	123.7	139.1	154.5	170.3	183.7	Radius
ft	1,000 lb											ft
10		481.2*	385.5*	352.5*	-	-	-	-	-	-	-	10
11		457.0*	384.2*	351.1*	-	-	-	-	-	-	-	11
13		414.7*	379.5*	348.4*	286.5	-	-	-	-	-	-	13
15		376.9*	370.9*	342.3*	286.2	-	-	-	-	-	-	15
16		358.1*	354.8*	335.6*	284.9	243.8	-	-	-	-	-	16
19		298.2*	294.2*	264.8*	239.0	217.6	197.4	-	-	-	-	19
23		237.5	222.2	204.6	191.4	169.4	151.8	138.6	-	-	-	23
26		189.1	181.9	168.3	159.1	141.2	131.0	116.4	110.1	-	-	26
29		151.9	155.6	146.4	134.3	125.5	114.9	106.7	99.8	91.4	-	29
33		113.6	122.3	120.2	109.5	106.1	96.8	93.3	84.7	77.0	73.8	33
39		-	87.3	88.8	89.6	83.0	78.9	73.9	67.0	61.1	58.6	39
46		-	62.4	66.6	67.0	66.8	62.0	58.0	52.3	47.5	45.9	46
52		-	49.3	53.1	53.5	54.1	51.5	48.2	43.2	39.0	37.9	52
59		-	-	41.7	42.1	42.6	41.5	39.3	34.9	31.1	30.2	59
65		-	-	34.8	35.1	35.7	34.6	33.4	29.4	25.8	25.2	65
72		-	-	-	28.8	29.2	28.1	27.2	24.1	20.8	20.4	72
79		-	-	-	23.8	24.3	22.9	22.1	19.9	16.8	16.4	79
85		-	-	-	-	20.6	19.3	18.4	16.2	13.8	13.5	85
92		-	-	-	-	17.1	15.8	14.9	12.9	10.9	10.5	92
98		-	-	-	-	14.7	13.4	12.5	10.3	8.5	8.5	98
105		-	-	-	-	-	11.0	10.1	8.1	6.3	6.3	105
111		-	-	-	-	-	9.2	8.3	6.1	4.3	4.5	111
118		-	-	-	-	-	-	6.4	4.4	-	-	118
124		-	-	-	-	-	-	5.0	-	-	-	124
131		-	-	-	-	-	-	-	-	-	-	131

Remarks

* with special attachment

Lifting capacities main boom with SSL

313,100 lb   **360°** **85 %**

Main boom

Radius	ft	108.3 *	123.7 *	139.1 *	154.5 *	170.3 **	183.7 **	Radius
ft					1,000 lb			ft
16	259.0	210.2	-	-	-	-	-	16
19	250.9	204.2	177.2	-	-	-	-	19
23	240.2	198.3	171.9	145.4	-	-	-	23
26	232.1	192.3	167.8	141.4	128.2	117.1	117.1	26
29	225.9	186.2	163.8	137.3	124.1	113.1	113.1	29
33	215.3	178.2	158.4	132.0	118.7	108.2	108.2	33
39	193.1	168.1	150.4	126.0	110.7	100.5	100.5	39
46	167.3	156.3	141.0	118.9	102.4	93.1	93.1	46
52	145.1	144.2	132.9	112.9	96.1	87.7	87.7	52
59	125.8	128.0	123.5	106.0	89.5	82.0	82.0	59
65	111.6	113.8	115.4	100.8	84.3	77.6	77.6	65
72	99.7	101.5	102.8	95.3	78.6	72.6	72.6	72
79	88.5	90.4	91.8	90.1	73.4	67.9	67.9	79
85	77.0	82.6	83.7	85.3	69.2	63.9	63.9	85
92	61.7	74.0	75.7	77.6	64.5	59.6	59.6	92
98	42.8	65.2	69.6	71.6	60.6	56.2	56.2	98
111	-	40.5	55.7	59.5	53.6	49.8	49.8	111
124	-	-	37.1	49.4	47.4	44.3	44.3	124
138	-	-	-	33.5	42.1	39.4	39.4	138
151	-	-	-	-	30.5	35.8	35.8	151
164	-	-	-	-	-	26.0	26.0	164

269,000 lb   **360°** **85 %**

Main boom

Radius	ft	108.3 *	123.7 *	139.1 *	154.5 *	170.3 **	183.7 **	Radius
ft					1,000 lb			ft
16	259.0	210.2	-	-	-	-	-	16
19	250.9	204.2	177.2	-	-	-	-	19
23	240.2	198.3	171.9	145.4	-	-	-	23
26	232.1	192.3	167.8	141.4	128.2	117.1	117.1	26
29	225.9	186.2	163.8	137.3	124.1	113.1	113.1	29
33	215.2	178.2	158.4	132.0	118.7	108.2	108.2	33
39	191.0	168.1	150.4	126.0	110.7	100.5	100.5	39
46	158.5	156.3	141.0	118.9	102.4	93.1	93.1	46
52	138.3	140.2	132.9	112.9	96.1	87.7	87.7	52
59	119.2	121.4	121.3	106.0	89.5	82.0	82.0	59
65	106.4	108.2	109.4	100.8	84.3	77.6	77.6	65
72	93.1	95.5	96.8	95.3	78.6	72.6	72.6	72
79	81.8	84.3	85.6	88.0	73.4	67.9	67.9	79
85	73.6	76.0	77.5	79.9	69.2	63.9	63.9	85
92	61.7	67.5	69.3	71.5	64.5	59.6	59.6	92
98	42.8	61.7	63.2	65.4	60.6	56.2	56.2	98
111	-	40.3	52.4	54.6	53.6	49.8	49.8	111
124	-	-	36.9	45.8	47.4	44.3	44.3	124
138	-	-	-	33.5	39.8	39.3	39.3	138
151	-	-	-	-	30.5	33.9	33.9	151
164	-	-	-	-	-	26.0	26.0	164

Remarks

- * SSL 0°
- ** SSL 30°



Notes to lifting capacity

Ratings are in compliance with ISO 4305 and DIN 15019.2 (test load = 1.25 x suspended load + 0.1 x dead weight of boom reduced to boom point).

Weight of hook blocks and slings is part of the load, and is to be deducted from the capacity ratings.

Crane operation with main boom is permissible up to a
wind pressure of 1.25 lb/ft²
wind speed of 32 ft

Consult operation manual for further details.

Note: Data published herein is intended as a guide only and shall not be construed to warrant applicability for lifting purposes. Crane operation is subject to the computer charts and operation manual both supplied with the crane.

Working ranges main boom extension with / without SSL

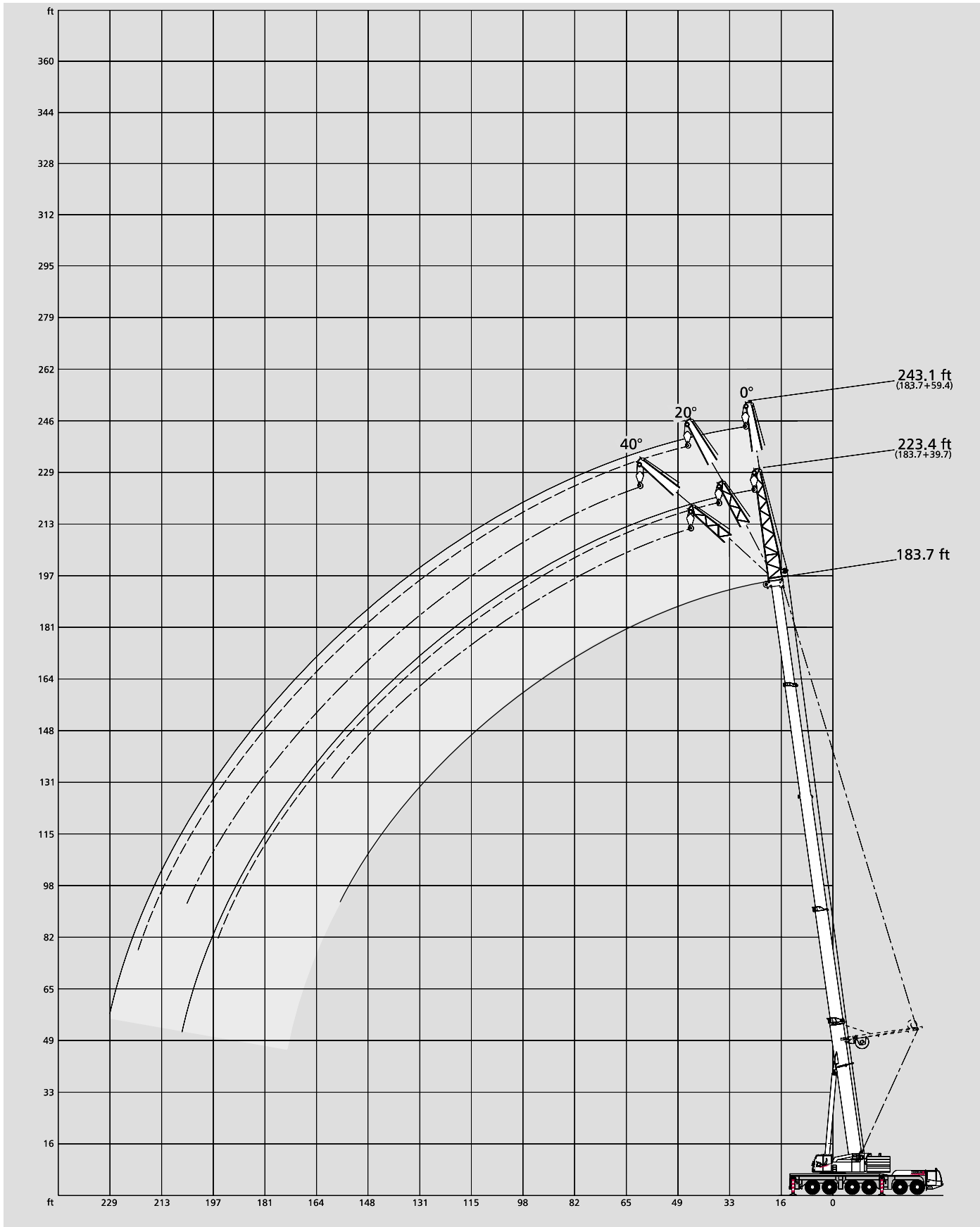

Lifting capacities main boom extension



360°

85%

170.3 ft Main boom

Radius ft	Extension 40.0 ft									Radius ft
	269,000 lb*			224,900 lb*			180,800 lb*			
	0°	20°	40°	0°	20°	40°	0°	20°	40°	
	1,000 lb									
39	61.4	-	-	61.4	-	-	61.4	-	-	39
46	58.1	-	-	58.1	-	-	58.1	-	-	46
52	55.3	39.1	-	55.3	39.1	-	55.3	39.1	-	52
59	52.0	37.2	28.6	52.0	37.2	28.6	52.0	37.2	28.6	59
65	49.4	35.8	28.0	49.4	35.8	28.0	49.4	35.8	28.0	65
72	46.1	34.4	27.3	46.1	34.4	27.3	46.1	34.4	27.3	72
79	42.8	33.0	26.8	42.8	33.0	26.8	42.8	33.0	26.8	79
85	40.2	32.0	26.2	40.2	32.0	26.2	40.2	32.0	26.2	85
92	37.6	30.8	25.7	37.6	30.8	25.7	37.6	30.8	25.7	92
98	35.4	30.0	25.3	35.4	30.0	25.3	35.4	30.0	25.3	98
111	31.6	28.2	24.7	31.6	28.2	24.7	31.6	28.2	24.7	111
124	29.0	26.9	24.0	29.0	26.9	24.0	29.0	26.9	24.0	124
138	26.8	25.5	23.8	26.8	25.5	23.8	26.8	25.5	23.8	138
151	25.1	24.0	23.5	25.1	24.0	23.5	23.3	24.0	23.5	151
164	22.9	22.2	-	22.9	22.2	-	19.4	20.0	-	164
177	20.5	20.5	-	20.5	20.5	-	16.1	16.5	-	177
187	18.7	18.9	-	18.7	18.9	-	13.8	14.3	-	187
190	18.3	-	-	18.3	-	-	13.2	-	-	190
203	-	-	-	-	-	-	-	-	-	203

170.3 ft Main boom

Radius ft	Extension 59.1 ft									Radius ft
	269,000 lb*			224,900 lb*			180,800 lb*			
	0°	20°	40°	0°	20°	40°	0°	20°	40°	
	1,000 lb									
39	38.3	-	-	38.3	-	-	38.3	-	-	39
46	37.6	-	-	37.6	-	-	37.6	-	-	46
52	36.8	-	-	36.8	-	-	36.8	-	-	52
59	36.1	-	-	36.1	-	-	36.1	-	-	59
62	35.7	30.6	-	35.7	30.6	-	35.7	30.6	-	62
65	35.3	30.2	-	35.3	30.2	-	35.3	30.2	-	65
72	34.4	29.1	-	34.4	29.1	-	34.4	29.1	-	72
79	33.4	28.1	24.4	33.4	28.1	24.4	33.4	28.1	24.4	79
85	32.4	27.3	23.8	32.4	27.3	23.8	32.4	27.3	23.8	85
92	31.2	26.6	23.3	31.2	26.6	23.3	31.2	26.6	23.3	92
98	30.4	25.8	22.9	30.4	25.8	22.9	30.4	25.8	22.9	98
111	28.1	24.5	22.2	28.1	24.5	22.2	28.1	24.5	22.2	111
124	25.9	23.4	21.8	25.9	23.4	21.8	25.9	23.4	21.8	124
138	23.5	22.0	21.1	23.5	22.0	21.1	23.5	22.0	21.1	138
151	21.5	20.7	20.2	21.5	20.7	20.2	21.5	20.7	20.2	151
164	19.8	19.4	19.4	19.8	19.4	19.4	19.8	19.4	19.4	164
170	19.2	19.0	19.0	19.2	19.0	19.0	18.4	18.8	19.0	170
177	18.5	18.3	-	18.5	18.3	-	16.7	17.8	-	177
190	17.2	17.2	-	17.2	17.2	-	13.9	14.8	-	190
203	15.7	16.1	-	15.7	16.1	-	11.5	12.2	-	203
213	14.5	-	-	14.5	-	-	10.1	-	-	213

Remarks

* counterweight



360°

85%

183.7 ft Main boom

Radius ft	Extension 40.0 ft									Radius ft
	269,000 lb*			224,900 lb*			180,800 lb*			
	0°	20°	40°	0°	20°	40°	0°	20°	40°	
46	50.4	-	-	50.4	-	-	50.4	-	-	46
52	47.8	-	-	47.8	-	-	47.8	-	-	52
56	45.9	37.6	-	45.9	37.6	-	45.9	37.6	-	56
59	44.5	36.8	-	44.5	36.8	-	44.5	36.8	-	59
65	42.1	35.4	27.8	42.1	35.4	27.8	42.1	35.4	27.8	65
72	39.3	33.7	27.3	39.3	33.7	27.3	39.3	33.7	27.3	72
79	36.9	32.3	26.6	36.9	32.3	26.6	36.9	32.3	26.6	79
85	35.1	30.9	26.2	35.1	30.9	26.2	35.1	30.9	26.2	85
92	33.2	29.7	25.5	33.2	29.7	25.5	33.2	29.7	25.5	92
98	31.8	28.5	25.1	31.8	28.5	25.1	31.8	28.5	25.1	98
111	28.7	26.3	24.0	28.7	26.3	24.0	28.7	26.3	24.0	111
124	26.1	24.5	22.9	26.1	24.5	22.9	26.1	24.5	22.9	124
138	23.7	22.6	21.8	23.7	22.6	21.8	23.7	22.6	21.8	138
151	22.0	21.3	20.7	22.0	21.3	20.7	22.0	21.3	20.7	151
164	20.5	20.0	19.8	20.5	20.0	19.8	19.1	20.0	19.8	164
177	18.9	18.7	-	18.9	18.7	-	15.9	16.5	-	177
190	17.4	17.2	-	17.4	17.2	-	13.0	13.5	-	190
200	16.1	15.8	-	16.1	15.8	-	11.2	11.4	-	200
203	15.7	-	-	15.7	-	-	10.6	-	-	203

183.7 ft Main boom

Radius ft	Extension 59.1 ft									Radius ft
	269,000 lb*			224,900 lb*			180,800 lb*			
	0°	20°	40°	0°	20°	40°	0°	20°	40°	
42	33.5	-	-	33.5	-	-	33.5	-	-	42
46	33.2	-	-	33.2	-	-	33.2	-	-	46
52	32.6	-	-	32.6	-	-	32.6	-	-	52
59	32.1	-	-	32.1	-	-	32.1	-	-	59
65	31.3	28.5	-	31.3	28.5	-	31.3	28.5	-	65
72	30.4	27.3	-	30.4	27.3	-	30.4	27.3	-	72
79	29.4	26.2	-	29.4	26.2	-	29.4	26.2	-	79
82	28.8	25.7	23.1	28.8	25.7	23.1	28.8	25.7	23.1	82
85	28.4	25.1	22.7	28.4	25.1	22.7	28.4	25.1	22.7	85
92	27.3	24.0	21.8	27.3	24.0	21.8	27.3	24.0	21.8	92
98	26.3	23.2	21.2	26.3	23.2	21.2	26.3	23.2	21.2	98
111	24.1	21.4	19.6	24.1	21.4	19.6	24.1	21.4	19.6	111
124	22.1	19.7	18.5	22.1	19.7	18.5	22.1	19.7	18.5	124
138	20.2	18.2	17.4	20.2	18.2	17.4	20.2	18.2	17.4	138
151	18.7	17.1	16.5	18.7	17.1	16.5	18.7	17.1	16.5	151
164	17.4	16.0	15.8	17.4	16.0	15.8	17.4	16.0	15.8	164
177	16.3	15.4	15.2	16.3	15.4	15.2	16.3	15.4	15.2	177
180	15.9	15.2	15.2	15.9	15.2	15.2	15.7	15.2	15.2	180
190	15.2	14.7	-	15.2	14.7	-	13.7	14.7	-	190
203	14.3	14.1	-	14.3	14.1	-	11.3	11.9	-	203
216	13.2	13.4	-	13.2	13.4	-	9.1	9.7	-	216
229	11.5	-	-	11.5	-	-	7.3	-	-	229
243	-	-	-	-	-	-	-	-	-	243

Remarks

* counterweight



Lifting capacities main boom extension with SSL 30°



360°

85%

170.3 ft Main boom

Radius ft	Extension 40.0 ft									Radius ft
	269,000 lb*			224,900 lb*			180,800 lb*			
	0°	20°	40°	0°	20°	40°	0°	20°	40°	
	1,000 lb									
33	75.3	-	-	75.3	-	-	75.3	-	-	33
39	75.3	-	-	75.3	-	-	75.3	-	-	39
46	72.9	44.2	-	72.9	44.2	-	72.9	44.2	-	46
52	69.3	42.2	-	69.3	42.2	-	69.3	42.2	-	52
56	66.8	40.9	29.9	66.8	40.9	29.9	66.8	40.9	29.9	56
59	64.8	40.1	29.7	64.8	40.1	29.7	64.8	40.1	29.7	59
65	61.4	38.5	28.9	61.4	38.5	28.9	61.4	38.5	28.9	65
72	57.4	36.8	28.2	57.4	36.8	28.2	57.4	36.8	28.2	72
79	53.6	35.2	27.5	53.6	35.2	27.5	53.6	35.2	27.5	79
85	50.6	34.0	26.9	50.6	34.0	26.9	50.6	34.0	26.9	85
92	47.3	32.8	26.4	47.3	32.8	26.4	47.3	32.8	26.4	92
98	44.9	31.8	26.0	44.9	31.8	26.0	44.9	31.8	26.0	98
111	40.3	29.8	25.1	40.3	29.8	25.1	39.6	29.8	25.1	111
124	36.5	28.2	24.5	36.5	28.2	24.5	32.5	28.2	24.5	124
138	33.2	26.8	24.2	33.2	26.8	24.2	25.9	26.8	24.2	138
151	30.8	25.7	24.0	28.4	25.7	24.0	21.1	22.4	23.1	151
164	28.6	24.9	-	23.8	24.6	-	17.2	18.0	-	164
177	26.4	24.2	-	19.8	20.5	-	13.9	14.5	-	177
187	21.6	24.0	-	17.4	17.8	-	11.6	12.1	-	187
190	20.0	-	-	16.6	-	-	11.0	-	-	190
203	-	-	-	-	-	-	-	-	-	203

170.3 ft Main boom

Radius ft	Extension 59.1 ft									Radius ft
	269,000 lb*			224,900 lb*			180,800 lb*			
	0°	20°	40°	0°	20°	40°	0°	20°	40°	
	1,000 lb									
33	47.3	-	-	47.3	-	-	47.3	-	-	33
39	46.5	-	-	46.5	-	-	46.5	-	-	39
46	45.4	-	-	45.4	-	-	45.4	-	-	46
52	44.1	-	-	44.1	-	-	44.1	-	-	52
56	43.1	34.1	-	43.1	34.1	-	43.1	34.1	-	56
59	42.5	33.5	-	42.5	33.5	-	42.5	33.5	-	59
65	40.9	32.3	-	40.9	32.3	-	40.9	32.3	-	65
69	40.0	31.5	26.0	40.0	31.5	26.0	40.0	31.5	26.0	69
72	39.2	31.1	25.8	39.2	31.1	25.8	39.2	31.1	25.8	72
79	37.8	29.9	25.1	37.8	29.9	25.1	37.8	29.9	25.1	79
85	36.4	28.9	24.7	36.4	28.9	24.7	36.4	28.9	24.7	85
92	35.0	27.9	24.2	35.0	27.9	24.2	35.0	27.9	24.2	92
98	33.8	27.1	23.6	33.8	27.1	23.6	33.8	27.1	23.6	98
111	31.1	25.8	22.7	31.1	25.8	22.7	31.1	25.8	22.7	111
124	28.9	24.5	22.0	28.9	24.5	22.0	28.9	24.5	22.0	124
138	26.8	23.3	21.5	26.8	23.3	21.5	26.8	23.3	21.5	138
151	25.3	22.4	21.1	25.3	22.4	21.1	22.2	22.4	21.1	151
164	24.0	21.8	20.9	24.0	21.8	20.9	18.3	20.0	20.9	164
174	23.1	21.3	20.9	21.5	21.3	20.9	15.6	17.1	18.0	174
177	22.9	21.3	-	20.9	21.3	-	15.0	16.3	-	177
190	21.8	20.9	-	17.7	18.7	-	12.1	13.0	-	190
203	20.1	20.7	-	14.8	15.5	-	9.5	10.4	-	203
210	15.1	-	-	13.6	-	-	8.5	-	-	210

Remarks

* counterweight



360°

85%

183.7 ft Main boom

Radius ft	Extension 40.0 ft									Radius ft
	269,000 lb*			224,900 lb*			180,800 lb*			
	0°	20°	40°	0°	20°	40°	0°	20°	40°	
46	50.4	-	-	50.4	-	-	50.4	-	-	46
52	47.8	-	-	47.8	-	-	47.8	-	-	52
56	45.9	37.6	-	45.9	37.6	-	45.9	37.6	-	56
59	44.5	36.8	-	44.5	36.8	-	44.5	36.8	-	59
65	42.1	35.4	27.8	42.1	35.4	27.8	42.1	35.4	27.8	65
72	39.3	33.7	27.3	39.3	33.7	27.3	39.3	33.7	27.3	72
79	36.9	32.3	26.6	36.9	32.3	26.6	36.9	32.3	26.6	79
85	35.1	30.9	26.2	35.1	30.9	26.2	35.1	30.9	26.2	85
92	33.2	29.7	25.5	33.2	29.7	25.5	33.2	29.7	25.5	92
98	31.8	28.5	25.1	31.8	28.5	25.1	31.8	28.5	25.1	98
111	28.7	26.3	24.0	28.7	26.3	24.0	28.7	26.3	24.0	111
124	26.1	24.5	22.9	26.1	24.5	22.9	26.1	24.5	22.9	124
138	23.7	22.6	21.8	23.7	22.6	21.8	23.7	22.6	21.8	138
151	22.0	21.3	20.7	22.0	21.3	20.7	22.0	21.3	20.7	151
164	20.5	20.0	19.8	20.5	20.0	19.8	19.1	20.0	19.8	164
177	18.9	18.7	-	18.9	18.7	-	15.9	16.5	-	177
190	17.4	17.2	-	17.4	17.2	-	13.0	13.5	-	190
200	16.1	15.8	-	16.1	15.8	-	11.2	11.4	-	200
203	15.7	-	-	15.7	-	-	10.6	-	-	203

183.7 ft Main boom

Radius ft	Extension 59.1 ft									Radius ft
	269,000 lb*			224,900 lb*			180,800 lb*			
	0°	20°	40°	0°	20°	40°	0°	20°	40°	
42	33.5	-	-	33.5	-	-	33.5	-	-	42
46	33.2	-	-	33.2	-	-	33.2	-	-	46
52	32.6	-	-	32.6	-	-	32.6	-	-	52
59	32.1	-	-	32.1	-	-	32.1	-	-	59
65	31.3	28.5	-	31.3	28.5	-	31.3	28.5	-	65
72	30.4	27.3	-	30.4	27.3	-	30.4	27.3	-	72
79	29.4	26.2	-	29.4	26.2	-	29.4	26.2	-	79
82	28.8	25.7	23.1	28.8	25.7	23.1	28.8	25.7	23.1	82
85	28.4	25.1	22.7	28.4	25.1	22.7	28.4	25.1	22.7	85
92	27.3	24.0	21.8	27.3	24.0	21.8	27.3	24.0	21.8	92
98	26.3	23.2	21.2	26.3	23.2	21.2	26.3	23.2	21.2	98
111	24.1	21.4	19.6	24.1	21.4	19.6	24.1	21.4	19.6	111
124	22.1	19.7	18.5	22.1	19.7	18.5	22.1	19.7	18.5	124
138	20.2	18.2	17.4	20.2	18.2	17.4	20.2	18.2	17.4	138
151	18.7	17.1	16.5	18.7	17.1	16.5	18.7	17.1	16.5	151
164	17.4	16.0	15.8	17.4	16.0	15.8	17.4	16.0	15.8	164
177	16.3	15.4	15.2	16.3	15.4	15.2	16.3	15.4	15.2	177
180	15.9	15.2	15.2	15.9	15.2	15.2	15.7	15.2	15.2	180
190	15.2	14.7	-	15.2	14.7	-	13.7	14.7	-	190
203	14.3	14.1	-	14.3	14.1	-	11.3	11.9	-	203
216	13.2	13.4	-	13.2	13.4	-	9.1	9.7	-	216
229	11.5	-	-	11.5	-	-	7.3	-	-	229
243	-	-	-	-	-	-	-	-	-	243

Remarks

* counterweight



Working ranges fixed fly jib (LF) with / without SSL

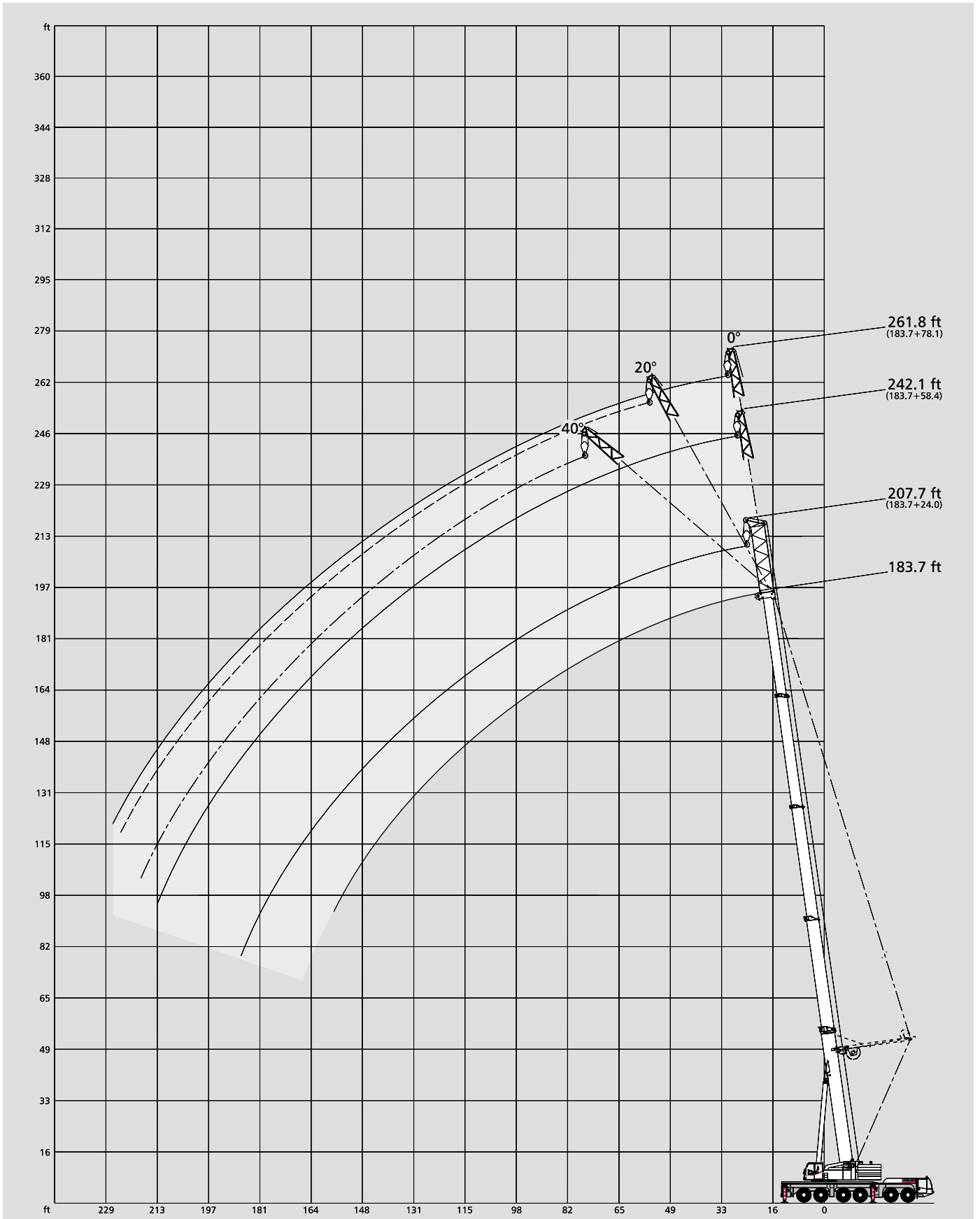

Lifting capacities fixed fly jib (LF)

224,900 lb   360° 85%

170.3 ft Main boom					
Radius ft	Fly jib				
	24.0 ft	58.7 ft	78.4 ft		
	0°	0°	0°	20°	40°
		1,000 lb			
36	70.3	-	-	-	-
39	68.1	-	-	-	-
42	65.9	48.9	-	-	-
46	63.2	47.3	-	-	-
49	61.2	46.3	37.3	-	-
52	59.3	45.1	36.3	-	-
59	55.3	42.7	34.1	-	-
65	52.1	40.7	32.5	-	-
72	48.8	38.6	30.9	-	-
75	47.3	37.8	30.2	21.8	-
79	45.7	36.5	29.4	21.3	-
85	43.3	34.9	28.0	20.7	-
92	40.7	33.2	26.8	20.0	15.6
98	38.7	31.6	25.8	19.4	15.2
111	34.7	28.7	23.8	18.1	14.7
124	31.4	26.3	22.1	17.2	14.3
138	28.1	24.0	20.4	16.5	13.8
151	25.5	22.0	19.1	15.8	13.6
164	22.7	20.5	18.0	15.2	13.4
177	20.0	19.1	16.7	14.7	13.4
190	-	17.8	15.6	14.1	13.4
203	-	16.5	14.7	13.6	-
213	-	15.2	13.9	13.2	-
216	-	-	13.7	13.0	-
223	-	-	13.2	12.5	-
229	-	-	12.8	-	-
236	-	-	-	-	-

183.7 ft Main boom					
Radius ft	Fly jib				
	24.0 ft	58.7 ft	78.4 ft		
	0°	0°	0°	20°	40°
		1,000 lb			
42	60.6	-	-	-	-
46	57.9	-	-	-	-
49	56.1	41.5	-	-	-
52	54.3	40.3	34.3	-	-
59	50.2	37.9	32.4	-	-
65	47.2	35.9	30.8	-	-
72	44.1	33.7	28.9	-	-
79	41.3	31.8	27.2	20.9	-
85	39.1	30.2	25.8	20.1	-
92	36.7	28.6	24.4	19.3	-
98	35.1	27.2	23.4	18.5	15.2
111	31.6	24.5	21.0	17.0	14.5
124	28.8	22.5	19.2	15.9	13.7
138	26.1	20.4	17.3	14.5	12.7
151	23.7	19.1	16.0	13.6	12.1
164	21.8	17.8	14.7	12.7	11.2
177	19.6	16.5	13.9	11.9	10.8
190	17.2	15.6	12.8	11.2	10.3
200	-	15.0	12.3	11.0	10.3
203	-	14.7	12.1	10.8	-
216	-	13.7	11.4	10.3	-
226	-	13.0	11.0	10.1	-
229	-	-	10.8	10.1	-
236	-	-	10.5	9.9	-
243	-	-	10.5	-	-
249	-	-	-	-	-
256	-	-	-	-	-

180,800 lb   360° 85%

170.3 ft Main boom					
Radius ft	Fly jib				
	24.0 ft	58.7 ft	78.4 ft		
	0°	0°	0°	20°	40°
		1,000 lb			
36	70.3	-	-	-	-
39	68.1	-	-	-	-
42	65.9	48.9	-	-	-
46	63.2	47.3	-	-	-
49	61.2	46.3	37.3	-	-
52	59.3	45.1	36.3	-	-
59	55.3	42.7	34.1	-	-
65	52.1	40.7	32.5	-	-
72	48.8	38.6	30.9	-	-
75	47.3	37.8	30.2	21.8	-
79	45.7	36.5	29.4	21.3	-
85	43.3	34.9	28.0	20.7	-
92	40.7	33.2	26.8	20.0	15.6
98	38.7	31.6	25.8	19.4	15.2
111	34.7	28.7	23.8	18.1	14.7
124	31.4	26.3	22.1	17.2	14.3
138	26.6	24.0	20.4	16.5	13.8
151	21.8	22.0	19.1	15.8	13.6
164	17.8	20.5	18.0	15.2	13.4
177	14.5	17.2	16.7	14.7	13.4
190	-	14.6	14.8	14.1	13.4
203	-	12.2	12.4	13.4	-
213	-	10.6	10.8	11.7	-
216	-	-	10.2	11.1	-
223	-	-	9.2	9.9	-
229	-	-	8.4	-	-
236	-	-	-	-	-

183.7 ft Main boom					
Radius ft	Fly jib				
	24.0 ft	58.7 ft	78.4 ft		
	0°	0°	0°	20°	40°
		1,000 lb			
42	60.6	-	-	-	-
46	57.9	-	-	-	-
49	56.1	41.5	-	-	-
52	54.3	40.3	34.3	-	-
59	50.2	37.9	32.4	-	-
65	47.2	35.9	30.8	-	-
72	44.1	33.7	28.9	-	-
79	41.3	31.8	27.2	20.9	-
85	39.1	30.2	25.8	20.1	-
92	36.7	28.6	24.4	19.3	-
98	35.1	27.2	23.4	18.5	15.2
111	31.6	24.5	21.0	17.0	14.5
124	28.8	22.5	19.2	15.9	13.7
138	26.1	20.4	17.3	14.5	12.7
151	21.8	19.1	16.0	13.6	12.1
164	17.8	17.8	14.7	12.7	11.2
177	14.5	16.5	13.9	11.9	10.8
190	11.7	14.1	12.8	11.2	10.3
200	-	12.3	12.1	11.0	10.3
203	-	11.7	11.9	10.8	-
216	-	9.7	9.7	10.3	-
226	-	8.4	8.4	9.0	-
229	-	-	8.0	8.8	-
236	-	-	7.2	7.7	-
243	-	-	6.3	-	-
249	-	-	-	-	-
256	-	-	-	-	-



Lifting capacities fixed fly jib (LF) with SSL 30°

313,100 lb



360°

85%

170.3 ft Main boom

Radius ft	Fly jib					
	40.0 ft			59.4 ft		
	0°	20°	40°	0°	20°	40°
	1,000 lb					
33	75.3	-	-	47.3	-	-
39	75.3	-	-	46.5	-	-
46	72.9	44.2	-	45.4	-	-
52	69.3	42.2	-	44.1	-	-
56	66.8	40.9	29.9	43.1	34.1	-
59	64.8	40.1	29.7	42.5	33.5	-
65	61.4	38.5	28.9	40.9	32.3	-
72	57.4	36.8	28.2	39.2	31.1	25.8
79	53.6	35.2	27.5	37.8	29.9	25.1
85	50.6	34.0	26.9	36.4	28.9	24.7
92	47.3	32.8	26.4	35.0	27.9	24.2
98	44.9	31.8	26.0	33.8	27.1	23.6
111	40.3	29.8	25.1	31.1	25.8	22.7
124	36.5	28.2	24.5	28.9	24.5	22.0
138	33.2	26.8	24.2	26.8	23.3	21.5
151	30.8	25.7	24.0	25.3	22.4	21.1
164	28.6	24.9	-	24.0	21.8	20.9
177	26.9	24.2	-	22.9	21.3	-
190	20.0	-	-	21.8	20.9	-
203	-	-	-	20.1	20.7	-
210	-	-	-	15.1	-	-

183.7 ft Main boom

Radius ft	Fly jib					
	40.0 ft			59.4 ft		
	0°	20°	40°	0°	20°	40°
	1,000 lb					
36	75.3	-	-	45.6	-	-
39	75.3	-	-	45.2	-	-
46	71.6	-	-	44.3	-	-
52	67.7	42.7	-	43.2	-	-
59	63.5	40.8	29.7	41.6	33.2	-
65	60.0	39.1	29.1	40.4	32.2	-
72	56.3	37.5	28.4	38.8	31.1	25.5
79	52.7	35.8	27.7	37.4	29.9	24.8
85	49.9	34.6	27.1	36.2	29.1	24.4
92	46.9	33.4	26.6	34.8	28.2	24.0
98	44.4	32.4	26.2	33.5	27.3	23.6
111	40.0	30.5	25.6	31.3	25.8	22.9
124	36.1	28.5	24.9	29.4	24.5	22.3
138	32.5	26.8	24.4	27.3	23.3	21.5
151	29.9	25.7	24.0	25.5	22.4	21.1
164	27.7	25.3	24.0	24.0	21.8	20.9
177	26.0	24.7	-	22.5	21.1	20.7
190	24.2	23.6	-	20.9	20.5	-
203	16.7	-	-	19.6	19.4	-
216	-	-	-	16.8	18.5	-
223	-	-	-	12.4	-	-

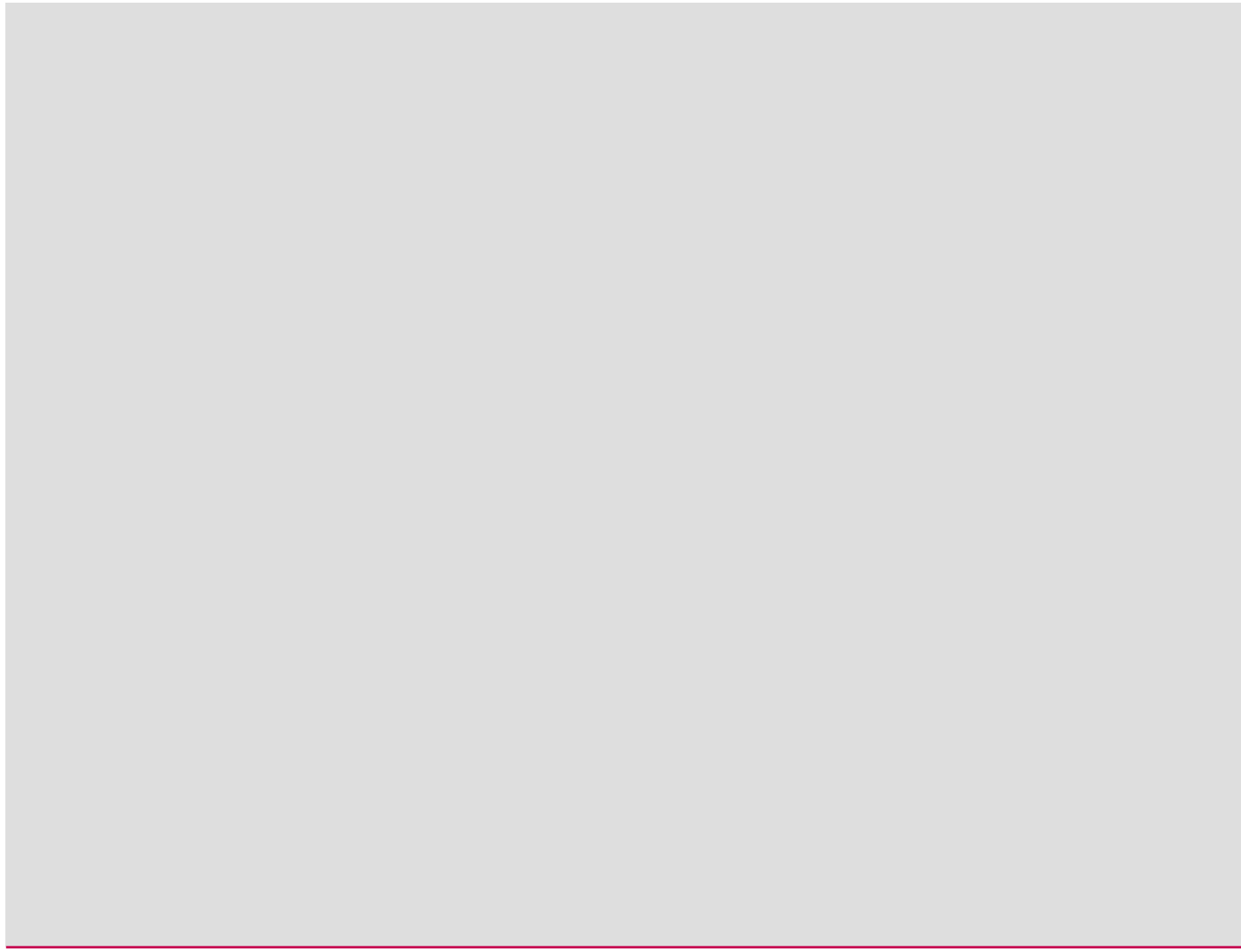

Working ranges fixed fly jib (SF) with / without SSL

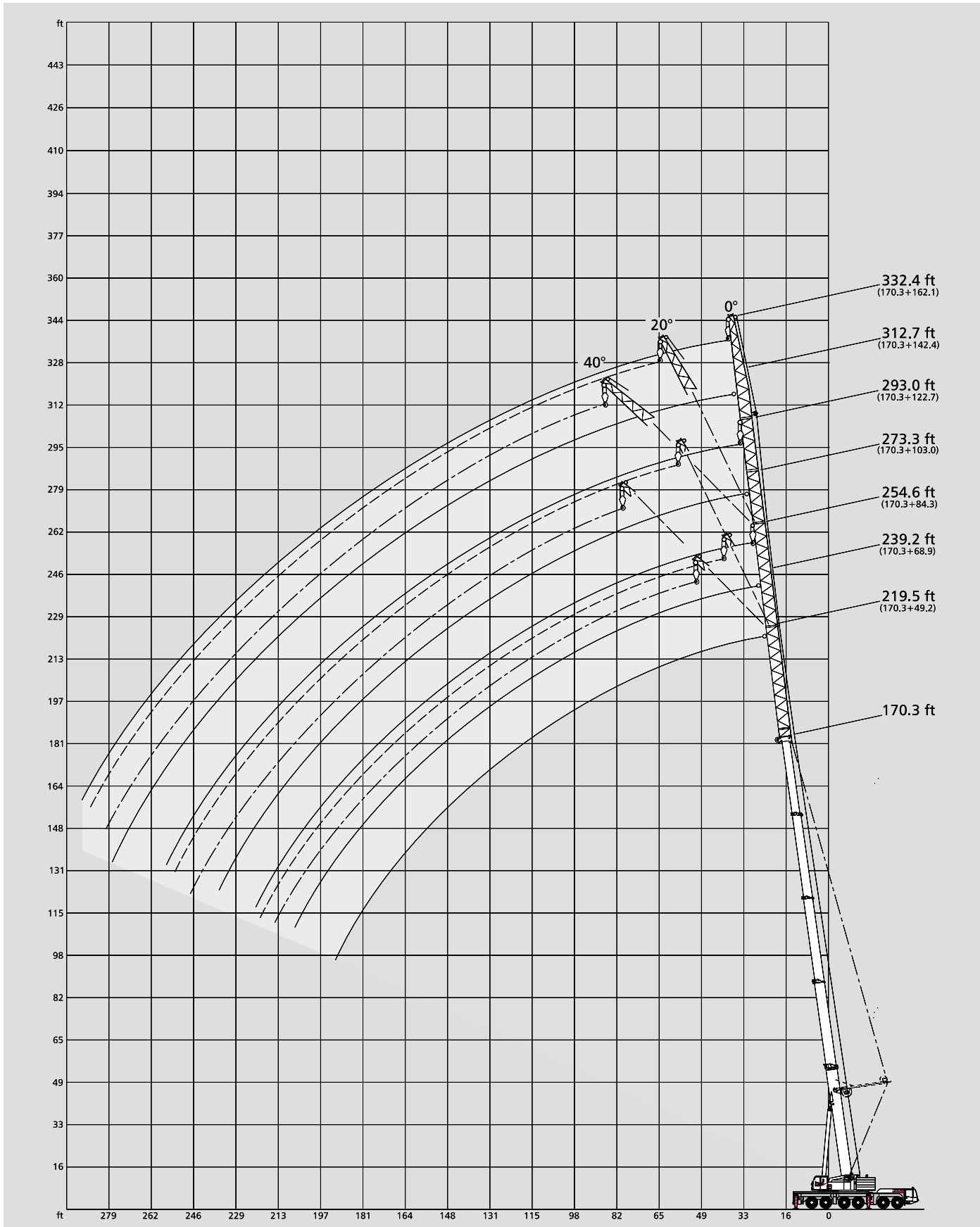

Lifting capacities fixed fly jib (SF)

224,900 lb 

 360°

85%

170.3 ft Main boom		Fly jib													
Radius ft	49.2 ft	68.9 ft	85.0 ft			103.7 ft	123.4 ft			143.1 ft	162.7 ft			Radius ft	
	0°	0°	0°	20°	40°	0°	0°	20°	40°	0°	0°	20°	40°		
	1,000 lb														
46	54.8	-	-	-	-	-	-	-	-	-	-	-	-	46	
49	53.0	45.0	-	-	-	-	-	-	-	-	-	-	-	49	
52	51.2	43.6	38.9	-	-	-	-	-	-	-	-	-	-	52	
59	47.4	40.8	36.3	-	-	31.9	-	-	-	-	-	-	-	59	
65	44.4	38.3	34.5	31.6	-	30.7	24.9	-	-	21.6	-	-	-	65	
72	41.3	35.7	32.4	30.0	-	29.3	24.0	-	-	20.9	16.3	-	-	72	
79	38.4	33.4	30.3	28.5	25.3	27.9	23.3	-	-	20.4	16.3	-	-	79	
85	36.2	31.6	28.9	27.1	24.9	26.7	22.5	-	-	19.8	16.1	-	-	85	
92	34.1	29.7	27.3	25.9	24.4	25.3	21.5	18.9	-	19.1	15.8	-	-	92	
98	32.3	28.1	25.8	24.7	23.8	24.1	20.9	18.5	-	18.5	15.4	-	-	98	
111	29.2	25.2	23.4	22.5	22.3	21.9	19.2	17.4	14.9	17.2	14.8	13.9	-	111	
124	26.3	22.8	21.2	20.3	20.5	19.7	17.5	16.3	14.5	15.7	13.7	12.6	12.8	124	
138	24.0	20.4	19.1	18.4	18.7	17.8	15.8	15.1	14.0	14.3	12.5	11.6	11.8	138	
151	22.0	18.7	17.6	16.9	17.1	16.3	14.3	14.1	13.4	13.0	11.4	10.7	11.0	151	
164	20.2	17.2	16.0	15.6	15.6	14.9	13.2	13.0	12.7	11.9	10.3	9.9	10.1	164	
177	18.5	15.8	15.0	14.5	14.5	13.9	12.1	12.1	12.1	10.8	9.2	9.2	9.2	177	
190	16.7	14.5	13.9	13.6	-	12.8	11.2	11.2	11.2	9.7	8.3	8.6	8.6	190	
203	14.8	13.4	12.8	12.8	-	11.9	10.3	10.3	10.3	9.0	7.7	7.9	7.9	203	
216	-	12.3	11.9	12.1	-	11.0	9.5	9.7	9.7	8.1	6.8	7.3	7.3	216	
229	-	-	11.2	11.7	-	10.3	8.8	9.0	9.0	7.5	6.2	6.6	6.8	229	
243	-	-	-	-	-	9.6	8.1	8.3	-	6.8	5.7	5.9	6.1	243	
256	-	-	-	-	-	9.2	7.7	7.9	-	6.3	5.0	5.2	5.7	256	
266	-	-	-	-	-	-	7.2	7.4	-	5.9	4.8	5.0	-	266	
269	-	-	-	-	-	-	7.2	-	-	5.9	4.6	4.8	-	269	
279	-	-	-	-	-	-	5.0	-	-	5.5	4.4	4.6	-	279	
282	-	-	-	-	-	-	-	-	-	5.5	4.1	4.4	-	282	
295	-	-	-	-	-	-	-	-	-	4.6	3.9	4.1	-	295	
305	-	-	-	-	-	-	-	-	-	-	3.7	3.9	-	305	
308	-	-	-	-	-	-	-	-	-	-	3.5	-	-	308	

183.7 ft Main boom		Fly jib													
Radius ft	49.2 ft	68.9 ft	85.0 ft			103.7 ft	123.4 ft			143.1 ft	162.7 ft			Radius ft	
	0°	0°	0°	20°	40°	0°	0°	20°	40°	0°	0°	20°	40°		
	1,000 lb														
49	43.7	-	-	-	-	-	-	-	-	-	-	-	-	49	
52	42.3	36.1	-	-	-	-	-	-	-	-	-	-	-	52	
56	40.6	34.5	29.7	-	-	-	-	-	-	-	-	-	-	56	
59	39.2	33.5	28.8	-	-	25.8	-	-	-	-	-	-	-	59	
65	36.8	31.5	27.2	-	-	24.3	20.5	-	-	-	-	-	-	65	
69	35.4	30.1	26.2	23.3	-	23.5	20.0	-	-	16.7	-	-	-	69	
72	34.4	29.3	25.6	22.7	-	22.9	19.6	-	-	16.5	12.1	-	-	72	
79	32.1	27.4	23.9	21.5	20.6	21.5	18.7	-	-	15.8	11.8	-	-	79	
85	30.5	25.8	22.7	20.5	19.8	20.5	17.8	-	-	15.2	11.4	-	-	85	
92	28.8	24.4	21.5	19.3	18.9	19.3	17.1	14.9	-	14.5	11.2	-	-	92	
98	27.4	23.0	20.5	18.5	18.1	18.3	16.3	14.3	-	13.9	10.8	-	-	98	
111	24.8	20.8	18.6	16.8	16.5	16.6	14.6	13.0	12.6	12.6	10.1	9.9	-	111	
124	22.8	18.8	17.0	15.5	15.2	15.0	13.0	11.9	11.5	11.5	9.3	9.0	8.6	124	
138	20.6	17.1	15.4	14.0	14.0	13.6	11.6	11.0	10.5	10.1	8.5	8.1	7.9	138	
151	19.1	15.6	14.3	13.0	13.0	12.5	10.5	9.9	9.6	9.2	7.7	7.4	7.0	151	
164	17.6	14.3	13.0	12.1	12.1	11.4	9.4	9.2	9.0	8.1	6.8	6.6	6.3	164	
177	16.3	13.2	12.1	11.2	11.4	10.8	8.8	8.3	8.3	7.5	6.1	5.9	5.7	177	
190	15.0	12.3	11.2	10.3	10.8	9.9	8.1	7.7	7.7	6.6	5.5	5.3	5.3	190	
203	13.7	11.4	10.6	9.9	-	9.2	7.5	7.0	7.2	6.1	4.8	4.6	4.6	203	
216	12.4	10.6	9.9	9.2	-	8.6	7.0	6.6	6.8	5.5	4.2	4.2	4.2	216	
229	-	9.9	9.2	8.8	-	7.9	6.4	5.9	6.4	4.8	3.7	3.7	3.7	229	
243	-	-	8.7	-	-	7.4	5.9	5.5	-	4.4	3.2	3.2	-	243	
256	-	-	-	-	-	7.0	5.5	5.2	-	3.9	-	-	-	256	
269	-	-	-	-	-	6.6	5.2	4.8	-	3.5	-	-	-	269	
279	-	-	-	-	-	-	5.0	4.8	-	-	-	-	-	279	
282	-	-	-	-	-	-	5.0	-	-	-	-	-	-	282	
289	-	-	-	-	-	-	3.9	-	-	-	-	-	-	289	
292	-	-	-	-	-	-	3.3	-	-	-	-	-	-	292	
305	-	-	-	-	-	-	-	-	-	-	-	-	-	305	

180,800 lb 



360°

85%

170.3 ft		Main boom																												
		Fly jib																												
		49.2 ft			68.9 ft			85.0 ft			103.7 ft			123.4 ft			143.1 ft			162.7 ft										
Radius	ft	0°			0°			0°			20°			40°			0°			0°			20°			40°			Radius	ft
		1,000 lb																												
46	54.8	-	-	-	-	-	-	-	-	-	-	-	-	-	-	-	-	-	-	-	-	-	-	-	-	46	46			
49	53.0	45.0	-	-	-	-	-	-	-	-	-	-	-	-	-	-	-	-	-	-	-	-	-	-	-	49	49			
52	51.2	43.6	38.9	-	-	-	-	-	-	-	-	-	-	-	-	-	-	-	-	-	-	-	-	-	-	52	52			
59	47.4	40.8	36.3	-	-	-	-	-	-	-	-	-	-	-	-	-	-	-	-	-	-	-	-	-	-	59	59			
65	44.4	38.3	34.5	31.6	-	-	-	-	-	-	-	-	-	-	-	-	-	-	-	-	-	-	-	-	-	65	65			
72	41.3	35.7	32.4	30.0	-	-	-	-	-	-	-	-	-	-	-	-	-	-	-	-	-	-	-	-	-	72	72			
79	38.4	33.4	30.3	28.5	25.3	-	-	-	-	-	-	-	-	-	-	-	-	-	-	-	-	-	-	-	-	79	79			
85	36.2	31.6	28.9	27.1	24.9	-	-	-	-	-	-	-	-	-	-	-	-	-	-	-	-	-	-	-	-	85	85			
92	34.1	29.7	27.3	25.9	24.4	-	-	-	-	-	-	-	-	-	-	-	-	-	-	-	-	-	-	-	-	92	92			
98	32.3	28.1	25.8	24.7	23.8	-	-	-	-	-	-	-	-	-	-	-	-	-	-	-	-	-	-	-	-	98	98			
111	29.2	25.2	23.4	22.5	22.3	-	-	-	-	-	-	-	-	-	-	-	-	-	-	-	-	-	-	-	-	111	111			
124	26.3	22.8	21.2	20.3	20.5	-	-	-	-	-	-	-	-	-	-	-	-	-	-	-	-	-	-	-	-	124	124			
138	24.0	20.4	19.1	18.4	18.7	-	-	-	-	-	-	-	-	-	-	-	-	-	-	-	-	-	-	-	-	138	138			
151	22.0	18.7	17.6	16.9	17.1	-	-	-	-	-	-	-	-	-	-	-	-	-	-	-	-	-	-	-	-	151	151			
164	18.0	17.2	16.0	15.6	15.6	-	-	-	-	-	-	-	-	-	-	-	-	-	-	-	-	-	-	-	-	164	164			
177	14.8	15.2	15.0	14.5	14.5	-	-	-	-	-	-	-	-	-	-	-	-	-	-	-	-	-	-	-	-	177	177			
190	11.9	12.4	13.7	13.6	-	-	-	-	-	-	-	-	-	-	-	-	-	-	-	-	-	-	-	-	-	190	190			
203	9.5	9.9	11.3	11.9	-	-	-	-	-	-	-	-	-	-	-	-	-	-	-	-	-	-	-	-	-	203	203			
216	-	8.0	9.3	9.7	-	-	-	-	-	-	-	-	-	-	-	-	-	-	-	-	-	-	-	-	-	216	216			
229	-	-	7.3	7.8	-	-	-	-	-	-	-	-	-	-	-	-	-	-	-	-	-	-	-	-	-	229	229			
243	-	-	-	-	-	-	-	-	-	-	-	-	-	-	-	-	-	-	-	-	-	-	-	-	-	243	243			
256	-	-	-	-	-	-	-	-	-	-	-	-	-	-	-	-	-	-	-	-	-	-	-	-	-	256	256			
266	-	-	-	-	-	-	-	-	-	-	-	-	-	-	-	-	-	-	-	-	-	-	-	-	-	266	266			
269	-	-	-	-	-	-	-	-	-	-	-	-	-	-	-	-	-	-	-	-	-	-	-	-	-	269	269			
279	-	-	-	-	-	-	-	-	-	-	-	-	-	-	-	-	-	-	-	-	-	-	-	-	-	279	279			

183.7 ft		Main boom																												
		Fly jib																												
		49.2 ft			68.9 ft			85.0 ft			103.7 ft			123.4 ft			143.1 ft			162.7 ft										
Radius	ft	0°			0°			0°			20°			40°			0°			0°			20°			40°			Radius	ft
		1,000 lb																												
49	43.7	-	-	-	-	-	-	-	-	-	-	-	-	-	-	-	-	-	-	-	-	-	-	-	-	49	49			
52	42.3	36.1	-	-	-	-	-	-	-	-	-	-	-	-	-	-	-	-	-	-	-	-	-	-	-	52	52			
56	40.6	34.5	29.7	-	-	-	-	-	-	-	-	-	-	-	-	-	-	-	-	-	-	-	-	-	-	56	56			
59	39.2	33.5	28.8	-	-	-	-	-	-	-	-	-	-	-	-	-	-	-	-	-	-	-	-	-	-	59	59			
65	36.8	31.5	27.2	-	-	-	-	-	-	-	-	-	-	-	-	-	-	-	-	-	-	-	-	-	-	65	65			
69	35.4	30.1	26.2	23.3	-	-	-	-	-	-	-	-	-	-	-	-	-	-	-	-	-	-	-	-	-	69	69			
72	34.4	29.3	25.6	22.7	-	-	-	-	-	-	-	-	-	-	-	-	-	-	-	-	-	-	-	-	-	72	72			
79	32.1	27.4	23.9	21.5	20.6	-	-	-	-	-	-	-	-	-	-	-	-	-	-	-	-	-	-	-	-	79	79			
85	30.5	25.8	22.7	20.5	19.8	-	-	-	-	-	-	-	-	-	-	-	-	-	-	-	-	-	-	-	-	85	85			
92	28.8	24.4	21.5	19.3	18.9	-	-	-	-	-	-	-	-	-	-	-	-	-	-	-	-	-	-	-	-	92	92			
98	27.4	23.0	20.5	18.5	18.1	-	-	-	-	-	-	-	-	-	-	-	-	-	-	-	-	-	-	-	-	98	98			
111	24.8	20.8	18.6	16.8	16.5	-	-	-	-	-	-	-	-	-	-	-	-	-	-	-	-	-	-	-	-	111	111			
124	22.8	18.8	17.0	15.5	15.2	-	-	-	-	-	-	-	-	-	-	-	-	-	-	-	-	-	-	-	-	124	124			
138	20.6	17.1	15.4	14.0	14.0	-	-	-	-	-	-	-	-	-	-	-	-	-	-	-	-	-	-	-	-	138	138			
151	19.1	15.6	14.3	13.0	13.0	-	-	-	-	-	-	-	-	-	-	-	-	-	-	-	-	-	-	-	-	151	151			
164	17.6	14.3	13.0	12.1	12.1	-	-	-	-	-	-	-	-	-	-	-	-	-	-	-	-	-	-	-	-	164	164			
177	14.3	13.2	12.1	11.2	11.4	-	-	-	-	-	-	-	-	-	-	-	-	-	-	-	-	-	-	-	-	177	177			
190	11.7	11.9	11.2	10.3	10.8	-	-	-	-	-	-	-	-	-	-	-	-	-	-	-	-	-	-	-	-	190	190			
203	9.3	9.5	10.6	9.9	-	-	-	-	-	-	-	-	-	-	-	-	-	-	-	-	-	-	-	-	-	203	203			
216	7.1	7.5	8.6	9.2	-	-	-	-	-	-	-	-	-	-	-	-	-	-	-	-	-	-	-	-	-	216	216			
229	-	5.6	6.9	7.3	-	-	-	-	-	-	-	-	-	-	-	-	-	-	-	-	-	-	-	-	-	229	229			
243	-	-	5.2	-	-	-	-	-	-	-	-	-	-	-	-	-	-	-	-	-	-	-	-	-	-	243	243			
256	-	-	-	-	-	-	-	-	-	-	-	-	-	-	-	-	-	-	-	-	-	-	-	-	-	256	256			
269	-	-	-	-	-	-	-	-	-	-	-	-	-	-	-	-	-	-	-	-	-	-	-	-	-	269	269			
279	-	-	-	-	-	-	-	-	-	-	-	-	-	-	-	-	-	-	-	-	-	-	-	-	-	279	279			

4

Lifting capacities fixed fly jib (SF) with SSL

313,100 lb



360°

85 %

170.3 ft Main boom																
Radius ft	49.2 ft		68.9 ft		85.0 ft			Fly jib 103.7 ft			123.4 ft		143.1 ft	162.7 ft		Radius ft
	0°	0°	0°	20°	40°	0°	20°	40°	0°	20°	40°	0°	0°	20°	40°	
1,000 lb																
36	80.5**	-	-	-	-	-	-	-	-	-	-	-	-	-	-	36
39	78.1**	-	-	-	-	-	-	-	-	-	-	-	-	-	-	39
42	75.7**	66.0**	56.0**	-	-	-	-	-	-	-	-	-	-	-	-	42
46	72.7**	63.6**	54.2**	-	-	44.7**	-	-	-	-	-	-	-	-	-	46
52	68.4**	60.2**	51.3**	-	-	42.5**	36.7**	-	-	-	-	-	-	-	-	52
59	64.1**	56.4**	48.3**	36.3*	-	40.1**	34.6**	-	-	33.3**	-	-	-	-	-	59
65	60.5**	53.6**	46.0**	35.5*	28.4*	38.3**	32.8**	-	-	31.4**	27.0**	-	-	-	-	65
72	56.7**	50.5**	43.4**	34.6*	28.0*	36.4**	31.1**	-	-	29.5**	25.6**	-	-	-	-	72
79	53.2**	47.7**	41.1**	33.4*	27.3*	34.5**	29.2**	21.1*	-	27.9**	23.9**	-	-	-	-	79
85	50.4**	45.3**	39.3**	32.4*	26.9*	33.1**	28.0**	20.7*	-	26.5**	22.9**	-	-	-	-	85
92	47.5**	42.7**	37.2**	31.5*	26.4*	31.4**	26.6**	20.0*	-	25.1**	21.5**	16.7*	-	-	-	92
98	45.1**	40.7**	35.6**	30.4*	26.0*	30.2**	25.4**	19.6*	15.4*	24.1**	20.7**	16.3*	-	-	-	98
111	40.5**	36.9**	32.5**	28.5*	25.3*	27.6**	23.2**	18.5*	14.7*	21.9**	18.8**	15.6*	14.5*	-	-	111
124	36.7**	33.6**	29.6**	26.7*	24.9*	25.4**	21.4**	17.4*	14.3*	20.1**	17.0**	14.8*	13.7*	-	-	124
138	33.4**	30.3**	27.0**	25.1*	24.2*	23.3**	19.8**	16.5*	14.1*	18.4**	15.6**	13.6*	12.7*	-	-	138
151	30.6**	27.9**	25.1**	24.0*	23.3*	21.8**	18.2**	15.6*	13.6*	16.9**	14.3**	12.7*	11.9*	-	-	151
164	28.2**	25.5**	23.3**	22.9*	22.4*	20.2**	16.9**	14.9*	13.4*	15.4**	13.2**	11.9*	11.2*	-	-	164
177	26.0**	23.1**	21.6**	21.8*	21.8*	18.9**	15.8**	14.1*	13.2*	14.1**	12.3**	11.0*	10.8*	-	-	177
190	21.7**	21.2**	20.3**	20.9*	21.1*	17.8**	15.0**	13.4*	12.7*	13.0**	11.4**	10.3*	10.1*	-	-	190
203	-	19.6**	18.9**	20.0*	-	17.0*	14.1**	12.8*	12.5*	12.1**	10.6**	9.9*	9.7*	-	-	203
216	-	13.7**	16.6**	18.1*	-	16.3*	13.4**	12.3*	12.3*	11.2**	9.9**	9.2*	9.2*	-	-	216
229	-	-	11.0**	12.4*	-	15.6*	12.8**	11.9*	12.1*	10.8**	9.2**	8.8*	8.8*	-	-	229
243	-	-	-	-	-	12.9*	12.3**	11.4*	-	10.1**	8.8**	8.3*	8.3*	-	-	243
256	-	-	-	-	-	6.5*	10.3**	11.2*	-	9.6**	8.3**	7.9*	7.9*	-	-	256
269	-	-	-	-	-	-	5.5**	7.9*	-	9.4**	7.9**	7.4*	-	-	-	269
282	-	-	-	-	-	-	-	-	-	6.8**	7.5**	7.2*	-	-	-	282
295	-	-	-	-	-	-	-	-	-	-	4.6**	6.6*	-	-	-	295
305	-	-	-	-	-	-	-	-	-	-	-	3.5*	-	-	-	305
315	-	-	-	-	-	-	-	-	-	-	-	-	-	-	-	315

183.7 ft Main boom																
Radius ft	49.2 ft		68.9 ft		85.0 ft			Fly jib 103.7 ft			123.4 ft		143.1 ft	162.7 ft		Radius ft
	0°	0°	0°	20°	40°	0°	20°	40°	0°	20°	40°	0°	0°	20°	40°	
1,000 lb																
39	71.4**	-	-	-	-	-	-	-	-	-	-	-	-	-	-	39
46	66.5**	57.9**	50.2**	-	-	-	-	-	-	-	-	-	-	-	-	46
52	62.9**	55.1**	48.0**	-	-	40.2**	-	-	-	-	-	-	-	-	-	52
59	58.8**	52.0**	45.6**	31.7*	-	38.5**	33.3**	-	-	-	-	-	-	-	-	59
65	55.8**	49.4**	43.6**	31.3*	-	37.2**	31.8**	-	-	30.1**	-	-	-	-	-	65
72	52.5**	46.8**	41.7**	30.6*	28.2*	35.5**	30.2**	-	-	28.6**	24.9**	-	-	-	-	72
79	49.4**	44.2**	39.6**	30.1*	27.7*	34.1**	28.6**	-	-	27.0**	23.5**	-	-	-	-	79
85	46.8**	42.2**	38.0**	29.7*	27.3*	32.7**	27.3**	19.8*	-	25.8**	22.5**	-	-	-	-	85
92	44.0**	39.8**	36.1**	28.8*	26.8*	31.0**	25.9**	19.3*	-	24.6**	21.1**	13.2*	-	-	-	92
98	42.0**	38.0**	34.5**	28.0*	26.4*	29.8**	24.9**	18.9*	-	23.4**	20.1**	13.2*	-	-	-	98
111	38.0*	34.3**	31.2**	26.5*	25.3*	27.2**	23.0**	18.1*	14.7*	21.2**	18.1**	12.7*	-	-	-	111
124	35.8*	31.0**	28.3**	24.9*	24.3*	25.0**	21.2**	17.2*	14.3*	19.2**	16.4**	12.5*	11.7*	-	-	124
138	33.6*	28.1**	25.7**	23.3*	23.1*	22.9**	19.6**	16.3*	13.8*	17.3**	14.9**	11.8*	11.2*	-	-	138
151	31.2*	26.2*	23.7**	22.0*	22.2*	21.3**	18.2**	15.4*	13.6*	16.0**	13.6**	11.2*	10.5*	-	-	151
164	28.8*	25.1*	21.8**	20.9*	21.1*	19.8**	16.9**	14.7*	13.4*	14.7**	12.7**	10.5*	9.9*	-	-	164
177	26.7*	23.8*	20.3**	20.0*	20.2*	18.5**	15.8**	14.1*	13.2*	13.6**	11.6**	9.9*	9.4*	-	-	177
190	24.3*	22.5*	19.4*	19.2*	19.4*	17.2**	14.7**	13.4*	12.7*	12.5**	10.8**	9.2*	8.8*	-	-	190
203	18.2*	20.9*	18.5*	18.3*	-	16.1**	13.9**	12.8*	12.5*	11.7**	9.9**	8.6*	8.3*	-	-	203
216	-	17.1*	17.6*	17.4*	-	15.2*	13.0**	12.3*	12.3*	11.0**	9.2**	7.9*	7.9*	-	-	216
229	-	11.1*	13.2*	14.6*	-	14.5*	12.3**	11.9*	12.1*	10.1**	8.6**	7.5*	7.5*	-	-	229
243	-	-	7.6*	9.1*	-	14.0*	11.6*	11.6*	-	9.6*	7.9**	7.0*	7.0*	-	-	243
256	-	-	-	-	-	10.5*	11.4*	11.2*	-	9.2*	7.4**	6.6*	6.6*	-	-	256
269	-	-	-	-	-	4.6*	7.7*	9.9*	-	8.8*	7.0**	6.3*	6.3*	-	-	269
282	-	-	-	-	-	-	-	5.5*	-	8.3*	6.6**	6.1*	-	-	-	282
295	-	-	-	-	-	-	-	-	-	4.9*	5.9*	5.7*	-	-	-	295
308	-	-	-	-	-	-	-	-	-	-	4.4*	5.5*	-	-	-	308
315	-	-	-	-	-	-	-	-	-	-	-	-	-	-	-	315

Remarks
 * SSL 0° ** SSL 30°

Working ranges luffing fly jib with / without SSL

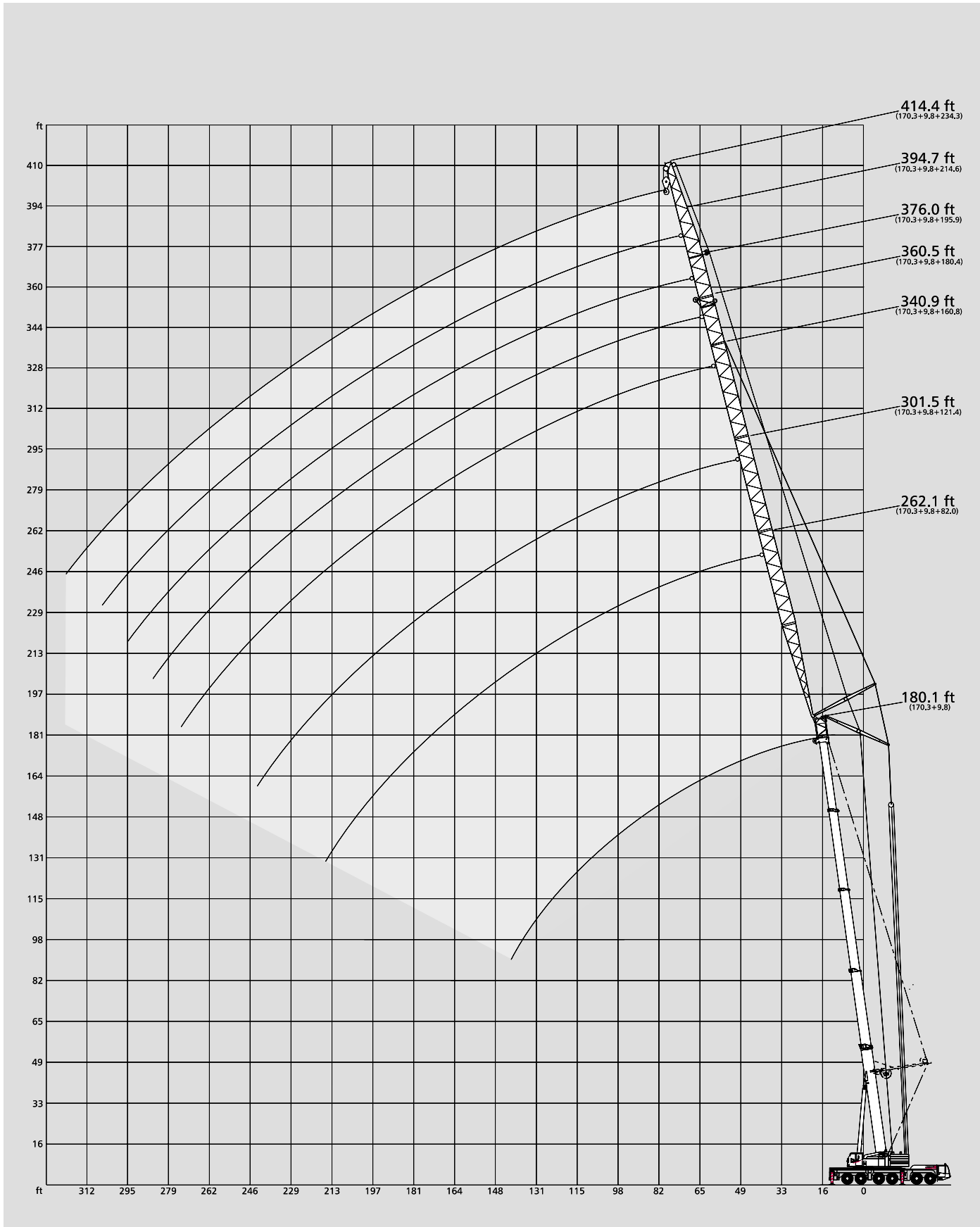

Lifting capacities luffing fly jib

269,000 lb



360°

85%

46.6 ft + 9.8 ft Main boom + adapter

Radius ft	Fly jib								Radius ft
	ft	82.0	121.4	160.8	180.5	196.5	215.2	234.9	
					1,000 lb				
39		147.8	-	-	-	-	-	-	39
46		145.4	98.3	-	-	-	-	-	46
52		139.3	96.6	60.0	-	-	-	-	52
59		132.3	94.8	59.3	46.9	-	-	-	59
65		124.2	93.2	58.9	46.5	36.8	30.2	-	65
72		112.7	91.1	58.4	46.0	36.8	29.9	22.4	72
79		92.3	89.2	57.9	45.6	36.5	29.5	22.0	79
85		-	87.3	57.3	45.2	36.3	29.3	21.8	85
92		-	82.5	56.8	44.5	36.1	29.0	21.3	92
98		-	75.6	56.4	43.9	35.9	28.8	21.1	98
111		-	56.3	55.3	42.3	35.0	28.0	20.5	111
124		-	-	53.1	40.8	34.4	27.3	19.8	124
138		-	-	45.6	36.9	33.4	26.6	19.1	138
151		-	-	34.7	33.2	31.7	25.7	18.5	151
164		-	-	-	29.9	29.9	24.4	17.6	164
177		-	-	-	-	27.3	23.3	16.9	177
190		-	-	-	-	22.3	22.5	16.3	190
203		-	-	-	-	-	21.8	15.8	203
216		-	-	-	-	-	-	15.2	216
226		-	-	-	-	-	-	14.9	226
239		-	-	-	-	-	-	-	239

62.0 ft + 9.8 ft Main boom + adapter

Radius ft	Fly jib								Radius ft
	ft	82.0	121.4	160.8	180.5	196.5	215.2	234.9	
					1,000 lb				
42		137.5	-	-	-	-	-	-	42
46		132.2	88.6	-	-	-	-	-	46
52		128.2	87.1	-	-	-	-	-	52
59		121.3	85.7	53.3	42.1	-	-	-	59
65		115.2	84.5	52.9	41.9	34.1	-	-	65
72		104.5	82.9	52.4	41.4	33.9	27.3	-	72
79		93.2	81.2	52.2	41.2	33.9	27.1	20.0	79
85		82.9	79.6	51.8	40.8	33.7	27.1	19.8	85
92		-	76.5	51.3	40.3	33.5	26.8	19.6	92
98		-	70.5	50.9	39.9	33.3	26.6	19.4	98
111		-	57.2	49.8	38.6	32.8	26.2	18.7	111
124		-	-	46.2	37.5	32.2	25.6	18.3	124
138		-	-	40.4	35.2	31.7	25.1	17.6	138
151		-	-	35.0	32.6	29.9	24.4	17.1	151
164		-	-	-	29.9	28.4	23.8	16.7	164
177		-	-	-	27.3	26.6	22.9	16.1	177
190		-	-	-	-	24.9	22.2	15.6	190
203		-	-	-	-	-	21.4	15.2	203
216		-	-	-	-	-	-	14.7	216
229		-	-	-	-	-	-	14.3	229
239		-	-	-	-	-	-	-	239

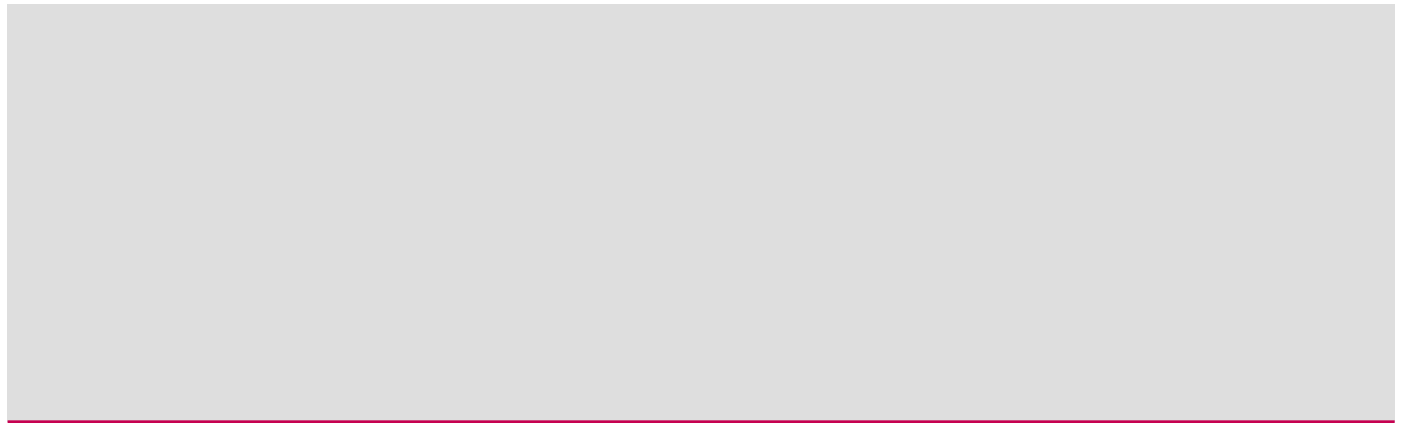

269,000 lb



360°

85 %

77.4 ft + 9.8 ft Main boom + adapter

Radius ft	ft	Fly jib							Radius ft
		82.0	121.4	160.8	180.5	196.5	215.2	234.9	
					1,000 lb				
46		123.3	-	-	-	-	-	-	46
52		117.3	77.8	-	-	-	-	-	52
59		110.2	76.7	47.1	-	-	-	-	59
65		105.6	75.7	46.7	37.0	30.8	-	-	65
72		99.5	74.5	46.5	36.8	30.8	24.6	-	72
79		93.2	73.3	46.2	36.5	30.8	24.6	18.0	79
85		87.8	72.1	46.0	36.3	30.8	24.4	17.8	85
92		-	70.9	45.6	36.1	30.8	24.4	17.6	92
98		-	67.2	45.4	35.7	30.8	24.4	17.4	98
111		-	56.6	44.7	35.0	30.4	24.0	17.2	111
124		-	45.9	42.8	34.4	30.2	23.8	16.7	124
138		-	-	38.5	33.0	29.7	23.3	16.3	138
151		-	-	34.5	31.2	28.8	23.1	15.8	151
164		-	-	-	29.3	27.5	22.4	15.6	164
177		-	-	-	27.5	26.4	22.0	15.2	177
190		-	-	-	-	25.1	21.6	14.7	190
203		-	-	-	-	-	21.1	14.3	203
216		-	-	-	-	-	-	14.1	216
229		-	-	-	-	-	-	13.6	229

108.3 ft + 9.8 ft Main boom + adapter

Radius ft	ft	Fly jib							Radius ft
		82.0	121.4	160.8	180.5	196.5	215.2	234.9	
					1,000 lb				
52		92.9	-	-	-	-	-	-	52
59		88.2	57.1	-	-	-	-	-	59
65		83.7	56.8	34.6	-	-	-	-	65
72		78.6	56.6	34.3	27.1	22.0	-	-	72
79		74.6	56.2	34.3	27.1	22.0	19.8	-	79
85		72.6	55.7	34.1	27.1	22.0	19.8	13.8	85
92		70.0	55.1	34.1	27.1	22.0	19.8	13.8	92
98		-	54.7	33.9	27.1	22.0	19.8	13.6	98
111		-	51.0	33.7	27.1	22.0	19.8	13.6	111
124		-	46.3	33.5	27.1	22.0	19.8	13.4	124
138		-	-	32.3	27.1	22.0	19.8	13.2	138
151		-	-	31.0	27.1	22.0	19.8	13.2	151
164		-	-	29.5	26.8	22.0	19.8	13.0	164
177		-	-	-	26.8	22.0	19.8	12.7	177
190		-	-	-	-	22.0	19.8	12.7	190
203		-	-	-	-	22.0	19.8	12.5	203
216		-	-	-	-	-	19.8	12.5	216
229		-	-	-	-	-	-	12.3	229
239		-	-	-	-	-	-	12.3	239



Lifting capacities luffing fly jib

269,000 lb



360°

85%

123.7 ft + 9.8 ft Main boom + adapter

Radius ft	Fly jib								Radius ft
	ft	82.0	121.4	160.8	180.5	196.5	215.2	234.9	
					1,000 lb				
59		74.7	46.9	-	-	-	-	-	59
65		72.3	46.9	-	-	-	-	-	65
72		69.3	46.9	28.2	-	-	-	-	72
79		66.2	46.9	28.2	24.0	19.8	-	-	79
85		64.2	46.7	28.2	24.0	19.8	15.6	-	85
92		62.1	46.7	28.2	24.0	19.8	15.6	11.6	92
98		-	46.5	28.2	24.0	19.8	15.6	11.6	98
111		-	45.6	28.2	24.0	19.8	15.6	11.6	111
124		-	43.9	28.2	24.0	19.8	15.6	11.6	124
138		-	-	28.2	24.0	19.8	15.6	11.6	138
151		-	-	28.2	24.0	19.8	15.6	11.6	151
164		-	-	28.2	24.0	19.8	15.6	11.6	164
177		-	-	-	24.0	19.8	15.6	11.6	177
190		-	-	-	24.0	19.8	15.6	11.6	190
203		-	-	-	-	19.8	15.6	11.6	203
216		-	-	-	-	-	15.6	11.6	216
229		-	-	-	-	-	-	11.6	229
243		-	-	-	-	-	-	11.6	243
256		-	-	-	-	-	-	-	256

139.1 ft + 9.8 ft Main boom + adapter

Radius ft	Fly jib								Radius ft
	ft	82.0	121.4	160.8	180.5	196.5	215.2	234.9	
					1,000 lb				
59		59.0	-	-	-	-	-	-	59
65		59.0	36.8	-	-	-	-	-	65
72		56.7	36.8	23.1	-	-	-	-	72
79		54.3	36.8	23.1	18.5	-	-	-	79
85		52.5	36.8	23.1	18.5	16.3	11.9	-	85
92		50.4	36.8	23.1	18.5	16.3	11.9	8.3	92
98		48.8	36.6	23.1	18.5	16.3	11.9	8.3	98
111		-	36.5	23.1	18.5	16.3	11.9	8.3	111
124		-	35.7	23.1	18.5	16.3	11.9	8.3	124
138		-	-	23.1	18.5	16.3	11.9	8.3	138
151		-	-	23.1	18.5	16.3	11.9	8.3	151
164		-	-	23.1	18.5	16.3	11.9	8.3	164
177		-	-	-	18.5	16.0	11.9	8.3	177
190		-	-	-	18.5	16.0	11.9	8.3	190
203		-	-	-	-	15.8	11.9	8.3	203
216		-	-	-	-	-	11.9	8.3	216
229		-	-	-	-	-	11.9	8.3	229
243		-	-	-	-	-	-	8.3	243
256		-	-	-	-	-	-	-	256

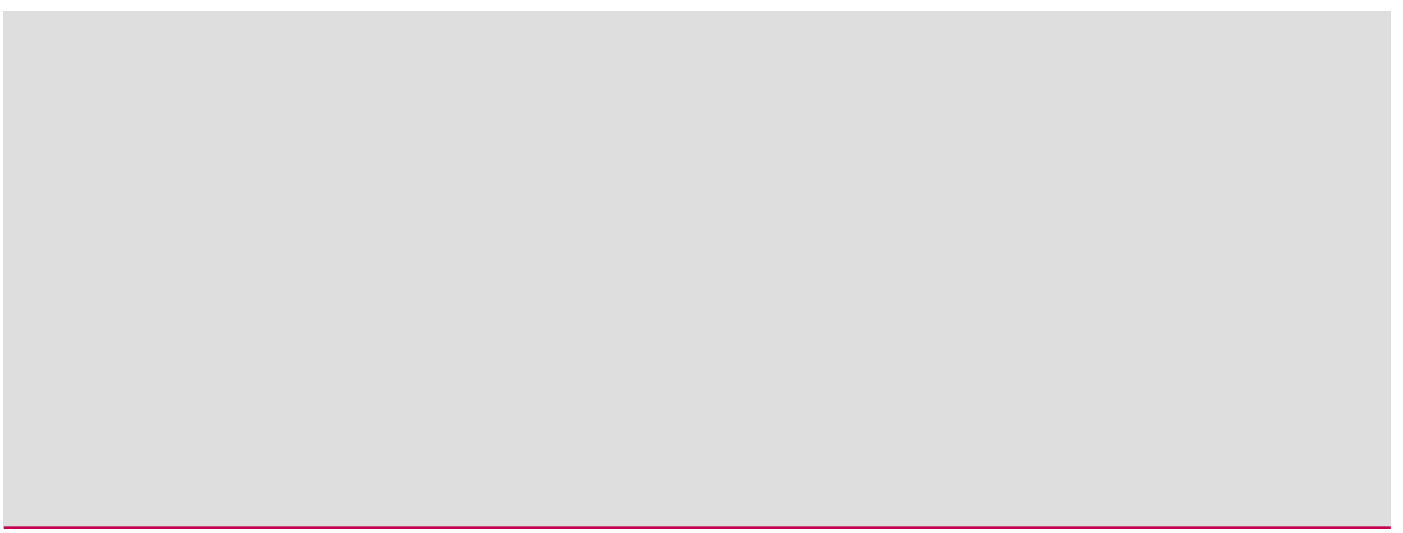

269,000 lb



360°

85 %

154.5 ft + 9.8 ft Main boom + adapter

Radius	Fly jib								Radius
	ft	82.0	121.4	160.8	180.5	196.5	215.2	234.9	
					1,000 lb				
65		44.5	26.6	-	-	-	-	-	65
72		44.1	26.6	-	-	-	-	-	72
79		43.4	26.6	18.0	-	-	-	-	79
85		42.8	26.6	18.0	14.3	11.0	-	-	85
92		41.6	26.6	18.0	14.3	11.0	7.9	-	92
98		40.4	26.6	18.0	14.3	11.0	7.9	5.0	98
111		-	26.6	18.0	14.3	11.0	7.9	5.0	111
124		-	26.6	18.0	14.3	11.0	7.9	5.0	124
138		-	26.6	18.0	14.3	11.0	7.9	5.0	138
151		-	-	18.0	14.3	11.0	7.9	5.0	151
164		-	-	18.0	14.3	11.0	7.9	5.0	164
177		-	-	18.0	14.3	11.0	7.9	5.0	177
190		-	-	-	14.3	11.0	7.9	5.0	190
203		-	-	-	-	11.0	7.9	5.0	203
216		-	-	-	-	-	7.9	5.0	216
229		-	-	-	-	-	7.9	5.0	229
243		-	-	-	-	-	-	5.0	243

170.3 ft + 9.8 ft Main boom + adapter

Radius	Fly jib								Radius
	ft	82.0	121.4	160.8	180.5	196.5	215.2	234.9	
					1,000 lb				
69		33.0	18.7	-	-	-	-	-	69
72		33.0	18.7	-	-	-	-	-	72
79		33.0	18.7	12.1	-	-	-	-	79
85		33.0	18.7	12.1	9.9	-	-	-	85
92		33.0	18.7	12.1	9.9	7.2	4.4	-	92
98		31.8	18.7	12.1	9.9	7.2	4.4	-	98
111		-	18.7	12.1	9.9	7.2	4.4	-	111
124		-	18.7	12.1	9.9	7.2	4.4	-	124
138		-	18.7	12.1	9.9	7.2	4.4	-	138
151		-	-	12.1	9.9	7.2	4.4	-	151
164		-	-	12.1	9.9	7.2	4.4	-	164
177		-	-	12.1	9.9	7.2	4.4	-	177
190		-	-	-	9.9	7.2	4.4	-	190
203		-	-	-	-	7.2	4.4	-	203
216		-	-	-	-	-	4.4	-	216
229		-	-	-	-	-	4.4	-	229
243		-	-	-	-	-	-	-	243

5

Lifting capacities luffing fly jib with SSL 60°

269,000 lb



360°

85 %

154.5 ft + 9.8 ft Main boom + adapter

Radius ft	Fly jib							Radius ft	
	ft	82.0	121.4	160.8	180.5	196.5	215.2		234.9
					1,000 lb				
65		61.4	-	-	-	-	-	-	65
69		59.0	39.2	-	-	-	-	-	69
72		57.2	38.6	-	-	-	-	-	72
79		53.6	37.6	-	-	-	-	-	79
82		52.2	37.0	28.4	-	-	-	-	82
85		51.0	36.6	28.0	-	-	-	-	85
88		49.6	36.2	27.8	24.7	21.4	-	-	88
92		48.0	35.4	27.3	24.4	21.1	-	-	92
95		46.7	35.0	27.1	24.0	20.9	16.5	-	95
98		45.5	34.6	26.7	23.8	20.7	16.5	12.3	98
111		-	32.5	25.4	22.7	19.6	15.6	11.9	111
124		-	30.5	24.3	21.6	18.5	15.0	11.2	124
138		-	28.4	22.9	20.4	17.6	14.0	10.7	138
151		-	-	21.8	19.3	16.7	13.4	10.1	151
164		-	-	20.5	18.5	15.8	12.7	9.7	164
177		-	-	19.4	17.4	14.7	12.1	9.2	177
190		-	-	-	16.3	13.9	11.4	8.8	190
203		-	-	-	-	13.0	10.8	8.1	203
216		-	-	-	-	-	10.1	7.7	216
229		-	-	-	-	-	9.3	7.2	229
243		-	-	-	-	-	-	6.8	243

170.3 ft + 9.8 ft Main boom + adapter

Radius ft	Fly jib							Radius ft	
	ft	82.0	121.4	160.8	180.5	196.5	215.2		234.9
					1,000 lb				
69		49.9	-	-	-	-	-	-	69
72		48.3	31.7	-	-	-	-	-	72
79		45.0	30.6	-	-	-	-	-	79
85		42.8	29.5	22.9	-	-	-	-	85
92		40.5	28.6	22.2	20.0	-	-	-	92
95		39.7	28.0	22.0	19.8	16.9	-	-	95
98		38.9	27.6	21.8	19.6	16.7	13.6	-	98
105		-	26.4	21.1	19.1	16.3	13.2	10.1	105
111		-	25.6	20.5	18.5	15.9	12.8	9.7	111
124		-	23.4	19.2	17.4	15.0	12.1	9.0	124
138		-	21.3	18.0	16.5	14.0	11.2	8.5	138
151		-	-	16.7	15.4	13.2	10.5	7.9	151
164		-	-	15.6	14.3	12.3	9.7	7.2	164
177		-	-	14.3	13.2	11.4	9.0	6.8	177
190		-	-	-	12.1	10.6	8.1	6.1	190
203		-	-	-	-	9.7	7.5	5.5	203
216		-	-	-	-	-	6.8	5.0	216
229		-	-	-	-	-	5.9	4.4	229
243		-	-	-	-	-	-	3.9	243

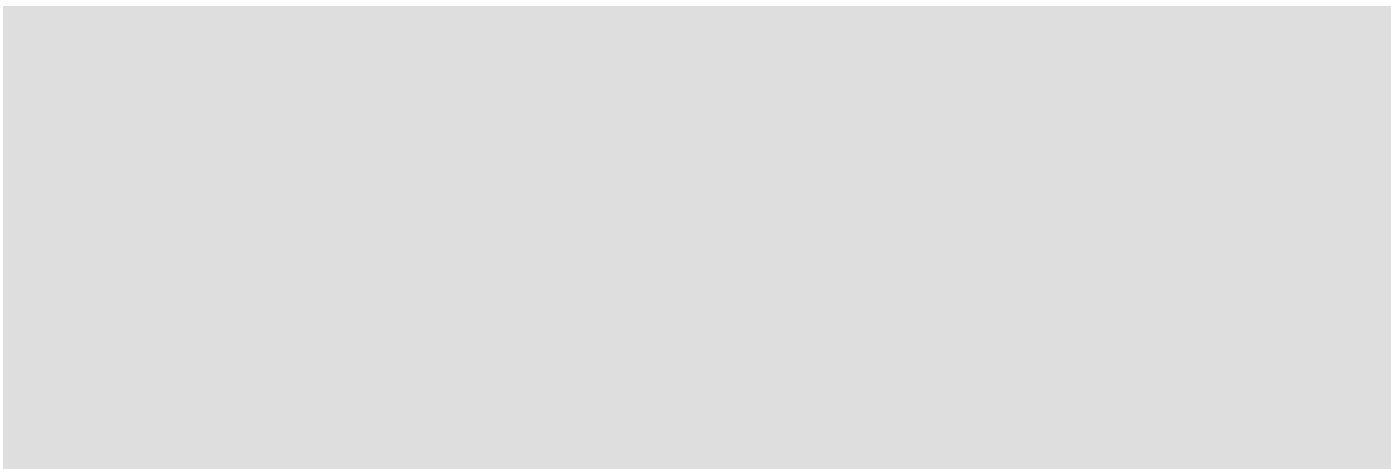

Technical description

Carrier

Drive / Steering	12 x 8 x 10.
Frame	Demag-built monobox main frame with outrigger boxes integral, of high strength fine grain structural steel.
Outriggers	4-point outrigger system, fully hydraulic horizontal and vertical extension.
Engine	Water-cooled 8-cylinder DaimlerChrysler diesel engine OM 502 LA, output 448 kW (601 hp) at 1800 1/min, torque 2700 Nm at 1200 1/min. Fuel tank capacity: 175 gallons for both carrier and superstructure.
Transmission	Allison type CLBT 755 with electronic transmission control (ATEC), torque converter and hydraulic retarder.
Axles	Axles 2, 3, 5 and 6 driven, 1, 2, 3, 5 and 6 steering. All drive axles with transverse differential lockout control, all axles hydro-pneumatically suspended and hydraulically blockable.
Wheels and tires	12 disk-type wheels 11.00-25/1.5" fitted with 16.00 R 25 tires.
Steering	Dual-circuit semiblock mechanical steering with hydraulic booster.
Brakes	to EC directives.
Electrical equipment	24 V system.
Driver's cab	Rubber-mounted low-line steel cab, ergonomic design, pneumatically suspended driver's and passenger's seat; electric window winders, heated outside mirrors, right-hand mirror electrically adjustable; dashboard with clearly arranged instrumentation and carrier controls, radio-cassette player.

Superstructure

Engine	DaimlerChrysler OM 906 LA water-cooled 6-cylinder diesel engine, rating: 205 kW (275 hp) at 2300 1/min, torque 1100 Nm at 1300 1/min. Fuel tank on carrier, 13.2 gallons additional tank on superstructure.
Hydraulic system	Powered via 7 hydraulic circuits, 4 main pumps and 3 auxiliary pumps for 4 independent control movements, servo control included.
Hoist 1	Variable-displacement axial-piston hydraulic motor, hoist drum with integral planetary gear reducer and brake.
Slew unit	Axial-piston hydraulic motor with planetary gear reducer, foot-pedal operated brake and spring-applied holding brake.
Boom elevation	One differential cylinder with pilot-controlled lowering brake valves.
Control	Electric pilot control by two 4-way self-centering hand levers.
Crane cab	Spacious all-steel comfortable cab (tiltable) with sliding door and large hinged windscreen, roof window with armoured glass, full instrumentation and crane controls, comfortable seat with ergonomic armrest mounted joystick controls, working light. Self-contained hot water heater with timer and 'Heizmatic' for sensitive heat flow control. Intermittent control window wiper, and washer.
Outrigger loading indicator	Indication of outrigger loading in upper cabin.
Main boom	Basic boom and 4 telescopic sections, fabricated from fine grain structural steel, hydraulically telescoping to full boom length, buckling-resistant Demag ovaloid cross section with diagonal self-centering slider shoes, boom head incl. parts to fit the optional jibs and foldaway extension, boom sections pinned hydraulically.
Counterweight	114,640 lb, divisible.
Safety devices	Electronic safe load indicator with easy-to-read graphic display and sealed touch-type keyboard, digital read-out for hook load, nominal load, radius, boom length and angle. Analog display to indicate capacity utilisation, and monitoring code to assist in trouble shooting. Integrated read-out for boom telescoping, display for duty charts and theoretical outrigger loading. In addition, the following safety devices have been installed: limit switches on hoist and lowering motions, pressure relief and safety holding valves, hoist rotation indicator and anemometer.

Optional equipment

Retarder	Telma retarder.
Night heater	Self-contained hot water heater for carrier cab.
Bunk bed	Carrier cab with bunk bed and roller blinds.
Air conditioning	Air conditioning for carrier cab.
Central lubrication	Central lubrication system for carrier.
Independent rear axle steering (crab steer)	The rear axles can be steered independent of the front axles. Axle 4 is raised hydraulically.
Tires	Disk-type wheels 17.00-25/1.7" fitted with 20.5 R 25 tires. Carrier width 10.2 ft.
Hoist 2	Variable-displacement axial-piston hydraulic motor, hoist drum with integral planetary gear reducer and brake.
Superlift attachment	This attachment, used to increase the crane's load moment, consists of both the boom suspension system with automatic rope length adjustment for boom telescoping and an additional counterweight of 154,324 lb or 198,416 lb. The boom suspension folds out, as required, at 0°, 30° and 60°, and can be lowered to the main boom when not needed or for road transport.
Additional counterweight	Max. 198,416 lb, to be integrated into standard counterweight, installs hydraulically without assist crane.
Main boom extension	39.7 ft and 59.4 ft, 0°, 20° and 40° offset, folding alongside basic boom.
Fixed fly jib (LF)	24.0 ft – 78.0 ft, consisting of components taken from the luffing jib.
Fixed fly jib (SF)	49.2 ft – 162.0 ft, consisting of components taken from the luffing jib.
Luffing fly jib	82.0 ft – 234.3 ft, with luffing mast, plus 9.8 ft adapter, pendant bars, electrical equipment and safety devices, the 2nd hoist is required when using the luffing fly jib.
Heavy-lift attachment 1	2 additional sheaves for duties 288,805 lb – 352,740 lb.
Heavy-lift attachment 2	6 additional sheaves for duties > 352,740 lb.
Heavy-lift attachment 3	2 pulley blocks with 11 sheaves each and connecting beam for duties > 529,109 lb.
Boom point sheave	Sheave folding to side of boom head.
Additional jack leg	For special duties with 46.6 ft main boom.
Auxiliary reeving winch	To simplify reeving of hook blocks.

Key



Counterweight



Lifting capacities on outriggers 360°

„D“

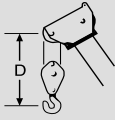

SSL:

Sideways Superlift

Notes

The information contained in this brochure merely consists of general descriptions and a broad compilation of performance features which might not apply precisely as described under specific application conditions or which may change as a result of further product development.
The desired performance features only become binding once expressly agreed in the final contract.

Subject to change without notice. · Machine operation is subject to computer charts only.

03/03

Terex Cranes Wilmington Operations

Mobile hydraulic and lattice-boom cranes
202 Raleigh St.
Wilmington, NC 28412 USA
Phone +1 910 395 8500
Fax +1 910 395 8538
Email american@american-crane.com

Order Nr. AC 350 USA B1 – 201 094 12

www.terex-cranes.com

Courtesy of Crane.Market