



**DEMAG CC6800** | Crawler Crane 1250 t Lifting Capacity



# DEMAG CC6800

## CRAWLER CRANE

# DEMAG CC6800 HIGHLIGHTS

- Excellent lifting capacities throughout all working ranges, especially with luffing fly jib
  - Max. load moment 13840 tm
  - Two redundant operating drivelines
  - Highly simplified assembly processes for short rigging times
  - Hydraulic quick-connection
  - Innovative Demag IC-1 crane control system with touchscreen
  - Superlift radius infinitely variable during operation from 15-24 m
  - Variable offset of main boom with SW and SWSL configurations
  - Powerful Quadro-Drive as standard
  - Hydraulic assisted pinning of boom sections is standard
  - PC outrigger optional
- 
- Hervorragende Tragfähigkeiten über alle Arbeitsbereiche, insbesondere am wippbaren Hilfsausleger
  - Max. Lastmoment 13840 mt
  - Zwei redundant arbeitende Antriebseinheiten
  - Enorm vereinfachte Montage und kürzeste Rüstzeiten
  - Hydraulische Schnellverbindung
  - Innovative Kransteuerung Demag IC-1 mit Touchscreen
  - Variabler Superlift-Radius verstellbar von 15-24 m
  - Variable Vorneigung Hauptausleger für SW und SWSL
  - Leistungsstarker Quadro-Antrieb serienmäßig
  - Serienmäßig hydraulisch verbolzbare Auslegerteile
  - Optionale PC-Abstützung
- 
- Excellentes capacités de levage dans tous les domaines de travail particulièrement avec volée variable
  - Couple de charge max. 13840 tm
  - Deux unités de propulsion avec redondance intégrée
  - Assemblages considérablement simplifiés et temps de montage réduit
  - Connexion rapide hydraulique entre châssis et partie tournante
  - Nouveau système de contrôle Demag IC-1 avec écran tactile
  - Rayon du Superlift variable 15-24 m
  - Flèche principale inclinable pour SW et SWSL
  - Puissant quadro en série
  - Boulonnement hydraulique des intercalaires de flèche en série
  - Base de calage variante PC en option

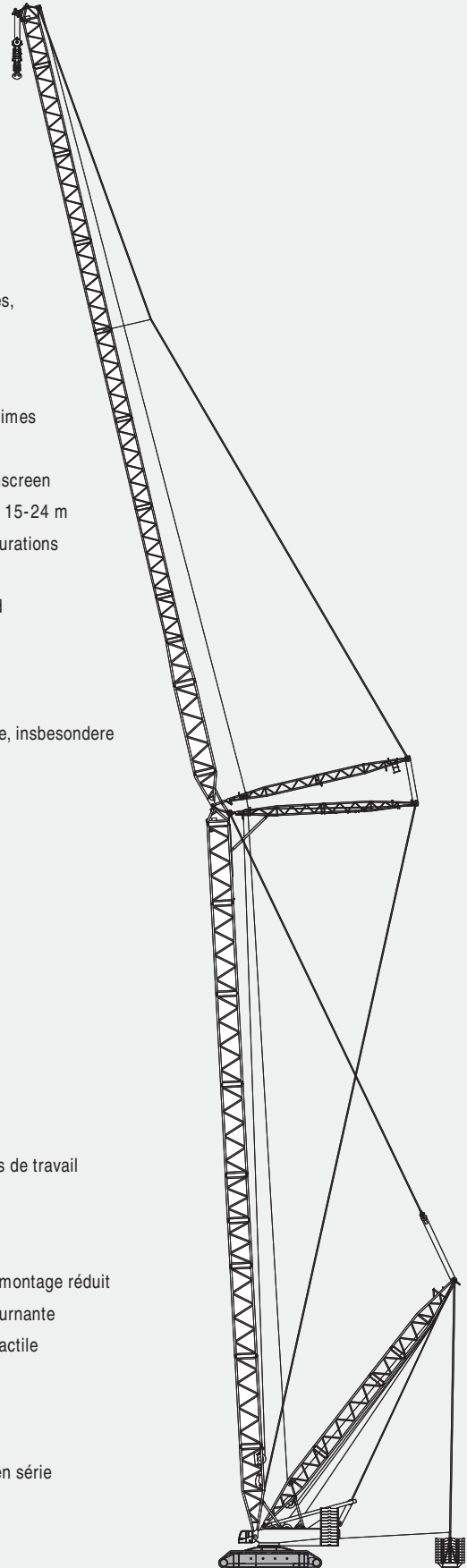

**CONTENTS · INHALT · CONTENU**

Page · Seite · Page:

**Specifications · Technische Daten · Caractéristiques**

Specifications · Technische Daten · Caractéristiques	4
Superlift configurations · Superlift-Konfigurationen · Combinaisons Superlift	9
Specifications · Technische Daten · Caractéristiques	10
Boom combinations · Ausleger-Kombinationen · Combinaisons de flèche	12

1

**Main boom · Hauptausleger · Flèche principale**

Working ranges · Arbeitsbereiche · Portées (SH, SH / LH, LH)	15
Lifting capacities · Tragfähigkeiten · Capacités de levage (SH, SH / LH, LH)	16
Working ranges with Superlift · Arbeitsbereiche mit Superlift · Portées avec Superlift (SSL, SSL / LSL)	19
Lifting capacities with Superlift · Tragfähigkeiten mit Superlift · Capacités de levage avec Superlift (SSL, SSL / LSL)	20

2

**Luffing fly jib · Wippbarer Hilfsausleger · Fléchette à volée variable**

Working ranges · Arbeitsbereiche · Portées (SW)	23
Lifting capacities · Tragfähigkeiten, Hauptausleger · Capacités de levage (SW)	24
Working ranges with SL, main boom 87° · Arbeitsbereiche mit SL, Hauptausleger 87° · Portées avec SL, flèche 87° (SWSL)	28
Lifting capacities with Superlift · Tragfähigkeiten mit Superlift · Capacités de levage avec Superlift (SWSL / SFSL 15°)	29

3

**Fixed fly jib · Starrer Hilfsausleger · Fléchette fixe**

Working ranges with SL · Arbeitsbereiche mit SL · Portées avec SL (SFVL / LFVL)	54
Lifting capacities with SL · Tragfähigkeiten mit SL · Capacités de levage avec SL (SFVL / LFVL)	55

4

**Technical description · Technische Beschreibung · Descriptif technique**

Crawler carrier · Superstructure · Optional equipment	56
Boom configurations S and L · Optional equipment	57
Raupenunterwagen · Oberwagen · Zusatzausrüstung	58
Auslegervarianten S und L · Zusatzausrüstung	59
Châssis à chenilles · Partie supérieure · Equipement optionnels	60
Combinaisons de flèche S et L · Equipement optionnels	61

5

**SPECIFICATIONS · TECHNISCHE DATEN · CARACTÉRISTIQUES**
**WORKING SPEEDS (INFINITELY VARIABLE) · ARBEITSGESCHWINDIGKEITEN (STUFENLOS  
REGELBAR) · VITESSES DE TRAVAIL (RÉGLABLES SANS PALIERS)**

Mechanisms Antriebe Mécanismes	Rope $\varnothing$ Seil- $\varnothing$ $\varnothing$ du câble	Speeds <sup>1)</sup> Geschwindigkeiten <sup>1)</sup> Vitesses <sup>1)</sup>	Single line pull Seilzug je Strang Effort sur brin simple	Length of hoist rope Länge des Hubseils Longueur du câble de levage
Hoist I+ II (H1+ H2) Hubwerk I+ II (H1+ H2) Treuil de levage I+ II (H1+ H2)	32 mm	max. 110 m / min	230 kN	1240 m
Hoist III (H3) Hubwerk III (H3) Treuil de levage III (H3)	32 mm	max. 100 m / min	230 kN	700 m
Boom derricking (W2) Wippwerk Hauptausleger (W2) Variation de flèche (W2)	32 mm	max. 110 m / min		
Boom hoist (E) Einziehwerk (E) Relevage de flèche (E)	32 mm	max. 50 m / min		
Jib luffing (W1) Wippwerk Hilfsausleger (W1) Variation de volée (W1)	32 mm	max. 105 m / min		
Slewing (rpm) Drehwerk (U/min) Orientation (tr/mn)		1,2		

<sup>1)</sup> top layer · oberste Lage · couche supérieure

**CARRIER PERFORMANCE · FAHRLEISTUNGEN · PERFORMANCES DU PORTEUR**

Travel speed · Fahrgeschwindigkeit · Vitesses de translation

max. 1,1 km/h

**SPECIFICATIONS · TECHNISCHE DATEN · CARACTÉRISTIQUES**
**HOOK BLOCK SYSTEMS · UNTERFLASCHENSYSTEME · SYSTÈMES DE CROCHET-MOUFLE**

Type Typ Type	Possible load Mögliche Traglast Charge possible	Number of sheaves Anzahl der Rollen Nombre de poulies	Number of lines Strangzahl Nombre de brins	Weight Gewicht Poids	„D“
2 x 625	1250 t	2 x 15	2 x 31	29 000 kg	7,90 m
	630 t	2 x 7	2 x 15	19 000 kg	5,90 m
	630 t	15	31	19 000 kg	5,90 m
	330 t	7	15	9 000 kg	5,90 m
1000	1000 t	2 x 11	2 x 23	18 000 kg	6,70 m
	500 t	2 x 5	2 x 11	11 000 kg	7,20 m (6,50 m*)
	500 t	11	23	8 000 kg	7,20 m (6,50 m*)
	250 t	5	11	7 600 kg (5 800 kg*)	7,20 m (6,00 m*)
800	800 t	2 x 11	2 x 19	16 000 kg	6,50 m
	500 t	2 x 5	2 x 11	11 000 kg	7,20 m (6,50 m*)
	500 t	11	23	8 000 kg	7,20 m (6,50 m*)
	250 t	5	11	7 600 kg (5 800 kg*)	7,20 m (6,00 m*)

\* with optional equipment 500 t hook  
mit optionalem 500 t Haken  
avec équipement optionnel: crochet de 500 t

**HOOK BLOCKS · UNTERFLASCHEN · CROCHET-MOUFLE**

Type Typ Type	Possible load Mögliche Traglast Charge possible	Number of sheaves Anzahl der Rollen Nombre de poulies	Number of lines Strangzahl Nombre de brins	Weight Gewicht Poids	„D“
70	70 t	1	3	3 900 kg	4,80 m
25	23 t	Single line hook / Hakengehänge / Boulet	1	1 500 kg	4,00 m

**SPECIFICATIONS · TECHNISCHE DATEN · CARACTÉRISTIQUES**

**BASIC CRANE DIMENSIONS · HAUPTABMESSUNGEN · DIMENSIONS DE LA GRUE DE BASE**

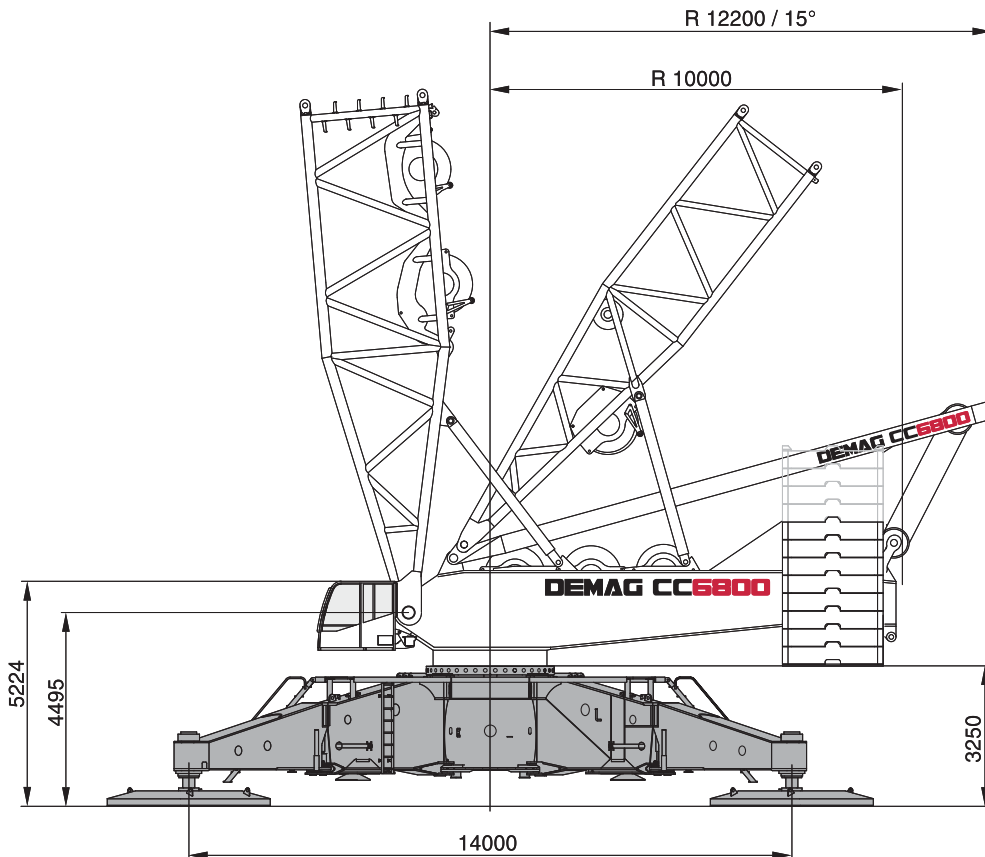
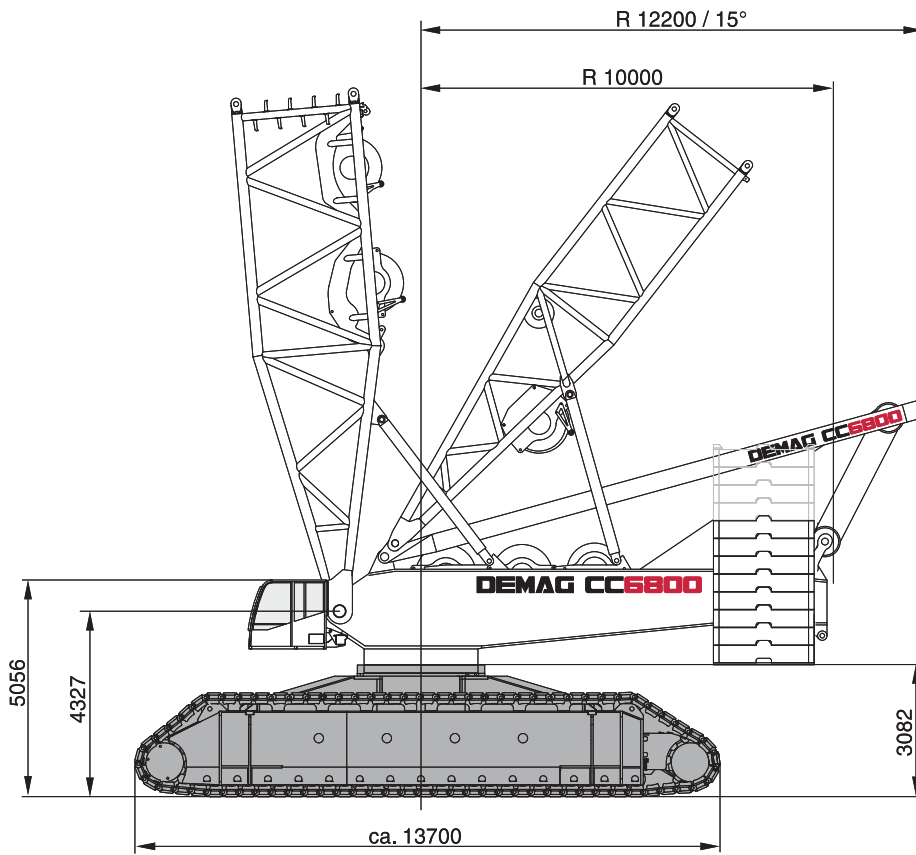

SPECIFICATIONS · TECHNISCHE DATEN · CARACTÉRISTIQUES

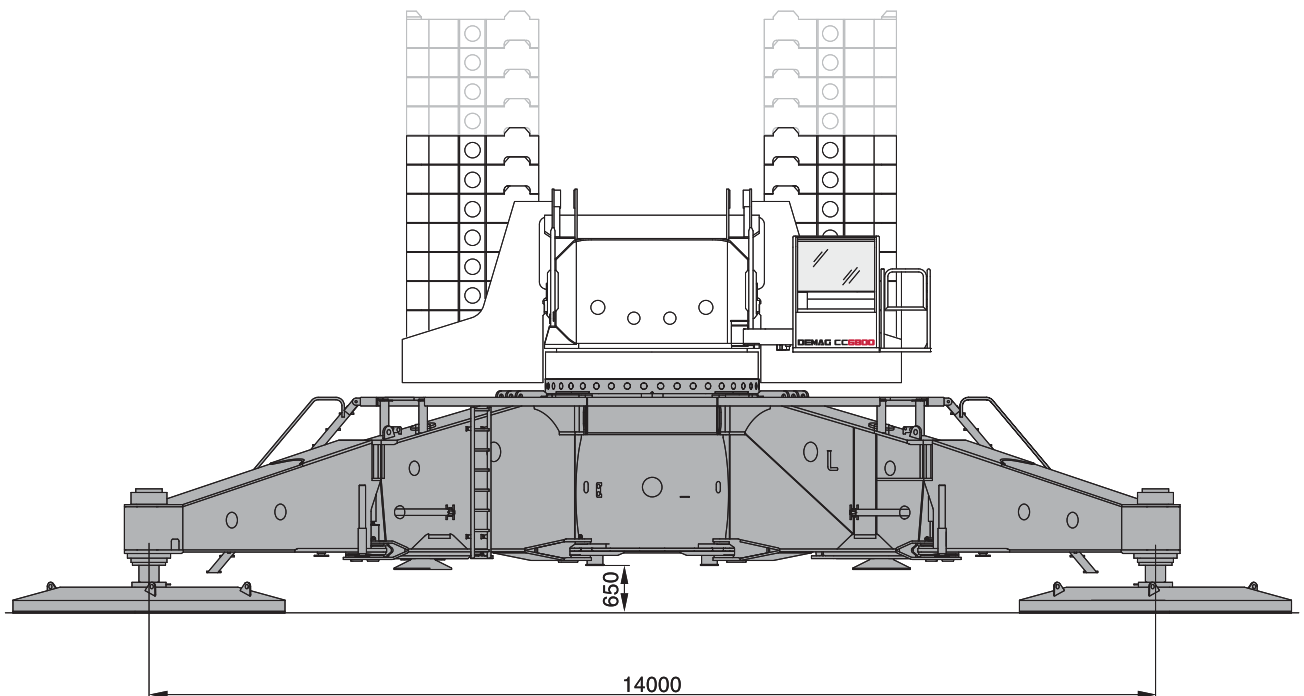
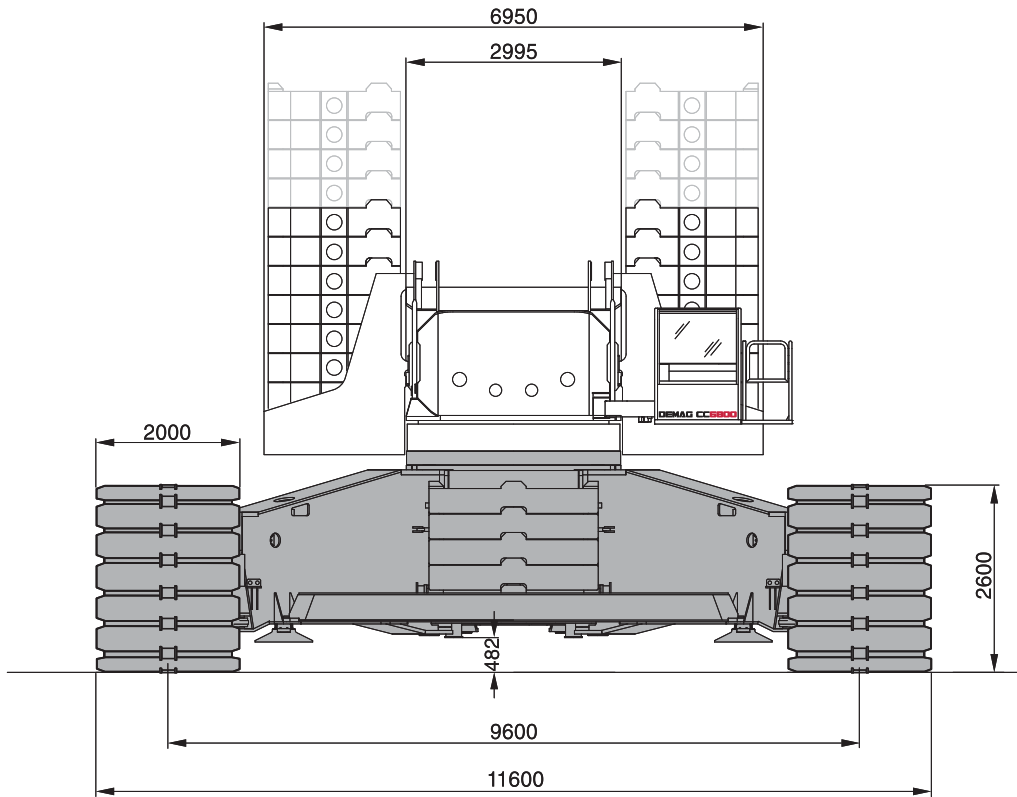

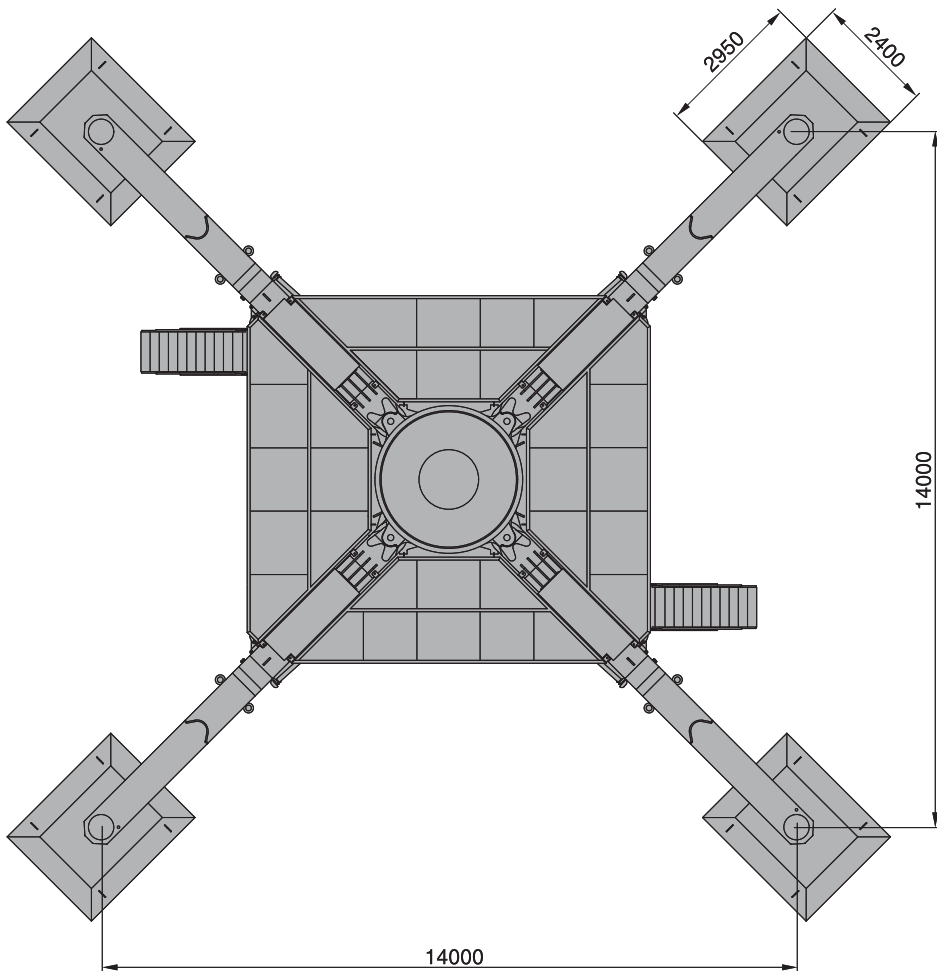
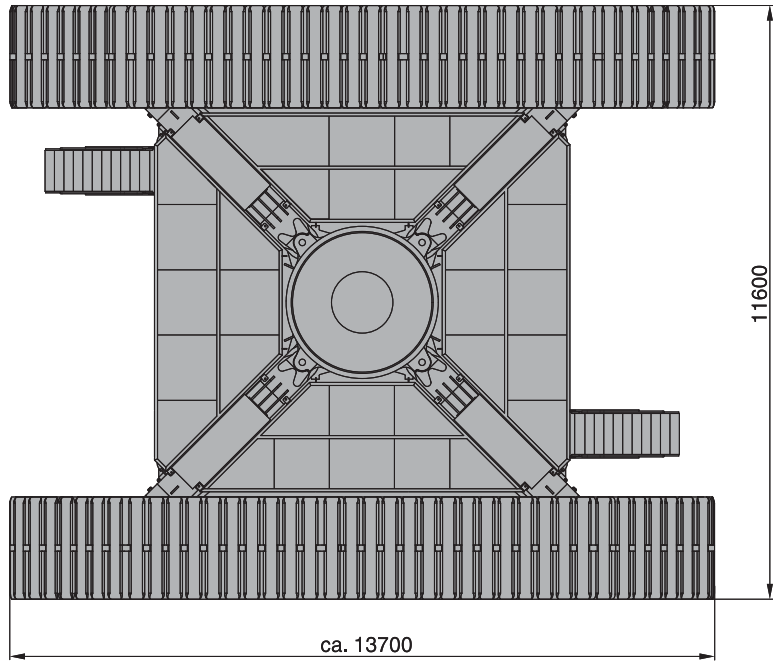



**SUPERLIFT CONFIGURATIONS · SUPERLIFT-KONFIGURATIONEN ·  
COMBINAISONS SUPERLIFT**

STANDARD SUPERLIFT ATTACHMENT · SERIENMÄSSIGE SUPERLIFTEINRICHTUNG ·  
SUPERLIFT DE SÉRIE

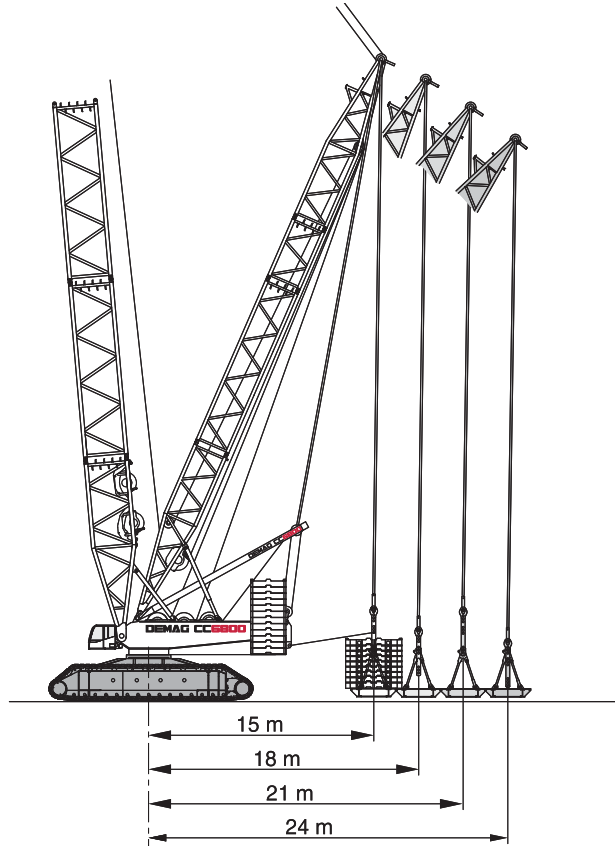

**VARIABLE SUPERLIFT ATTACHMENT · VARIABLE SUPERLIFTEINRICHTUNG · SUPERLIFT VARIABLE**

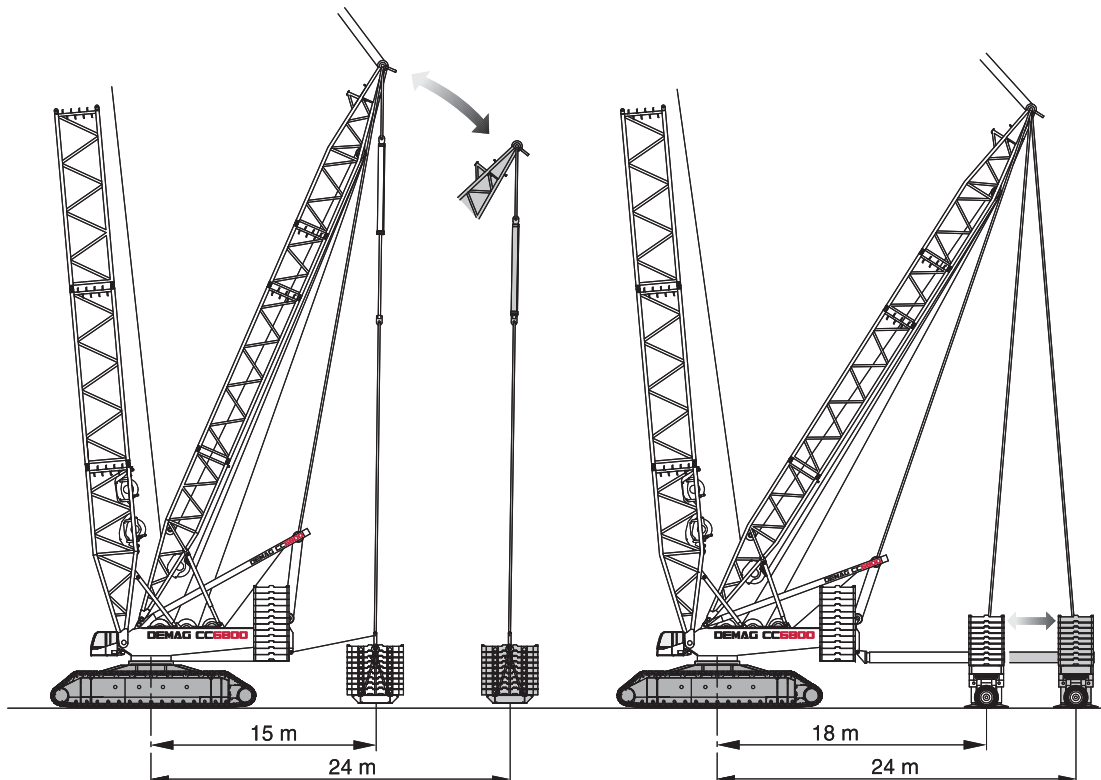

**SPECIFICATIONS · TECHNISCHE DATEN · CARACTÉRISTIQUES**

**WEIGHTS · GEWICHTE · POIDS**

Total weight incl. 170 t counterweight, 36 m boom and hook block Gesamtgewicht einschl. 170 t Gegengewicht, 36 m Hauptausleger und Unterflasche Poids avec 170 t de contrepoids, flèche de 36 m et crochet	528 t
Superstructure (with 3 winches, A-frame and quick-connection) Oberwagen (mit 3 Winden, A-Bock und Schnellverbindung) Partie supérieure (avec 3 tambours, chevalet et connexion rapide)	89 t
Superstructure without winches and A-frame Oberwagen ohne Winden und A-Bock Partie supérieure sans tambours et chevalet	53 t
Carbody with jacks and quick-connection Mittelstück mit Abstützung und Schnellverbindung Partie centrale avec appuis et connexion rapide	46 t
Crawlers with track shoes (2000 mm) Raupen mit Bodenplatten (2000 mm) Chenilles avec patins (2000 mm)	69 t
Crawlers without track shoes Raupen ohne Bodenplatten Chenilles sans patins	39 t
Counterweight Gegengewicht Contrepoids	170 t

**GROUND PRESSURE · BODENDRUCK · PRESSION AU SOL**

Ground pressure (based on total weight of 528 t) Bodendruck (bei 528 t Gesamtgewicht) Pression au sol (pour un poids total de 528 t)	13,6 N / cm <sup>2</sup>
--	--------------------------

**COUNTERWEIGHT · GEGENGEWICHT · CONTREPOIDS**

Central ballast (ZB)  
Zentralballast (ZB)  
Lest central (ZB)

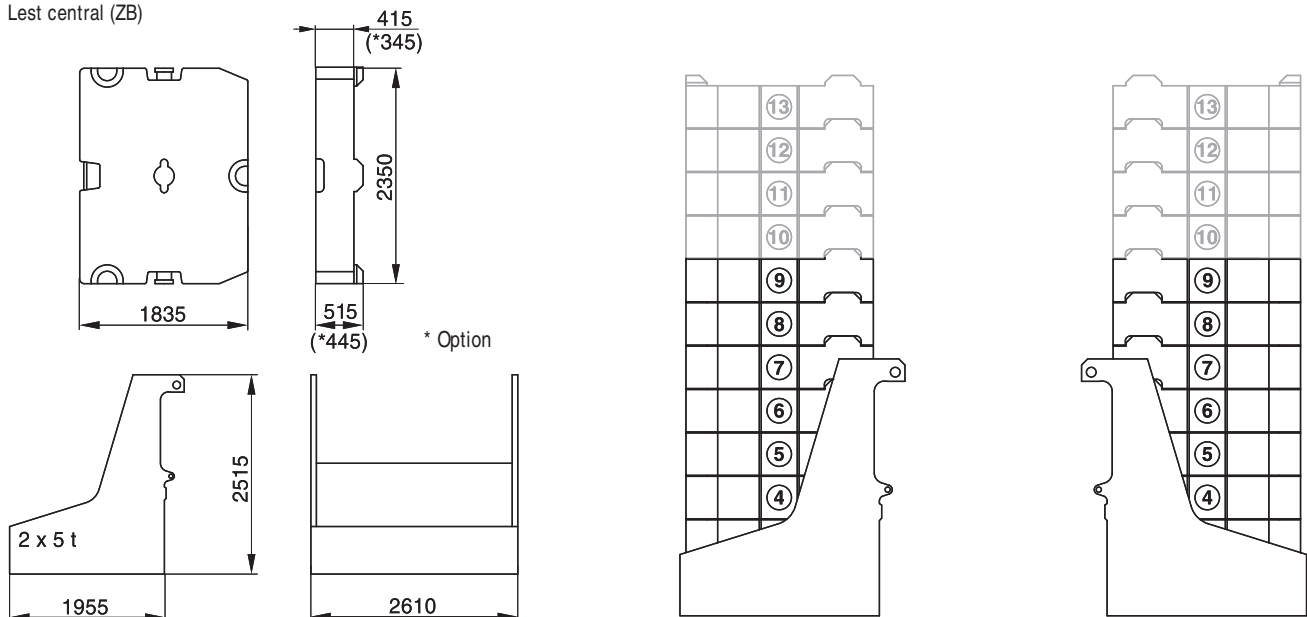

SPECIFICATIONS · TECHNISCHE DATEN · CARACTÉRISTIQUES

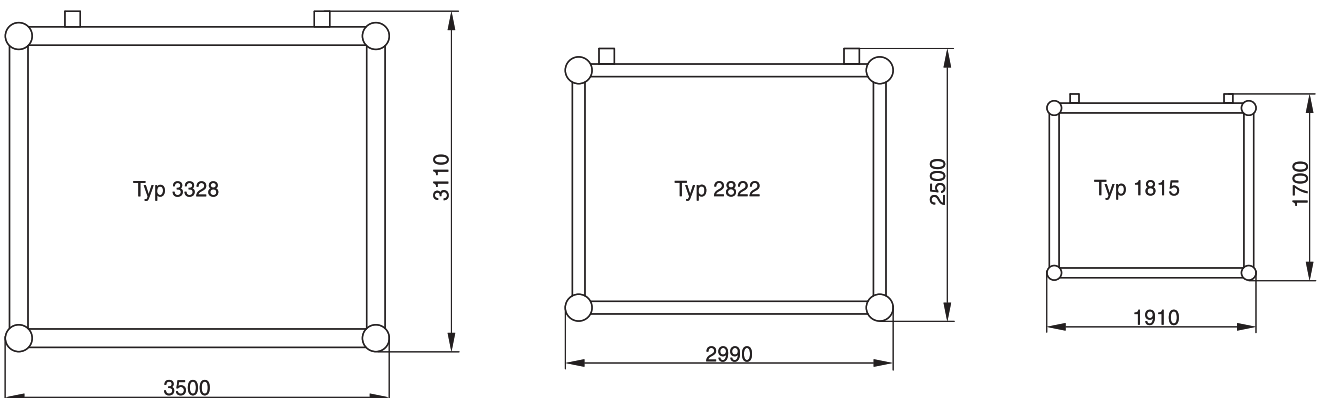
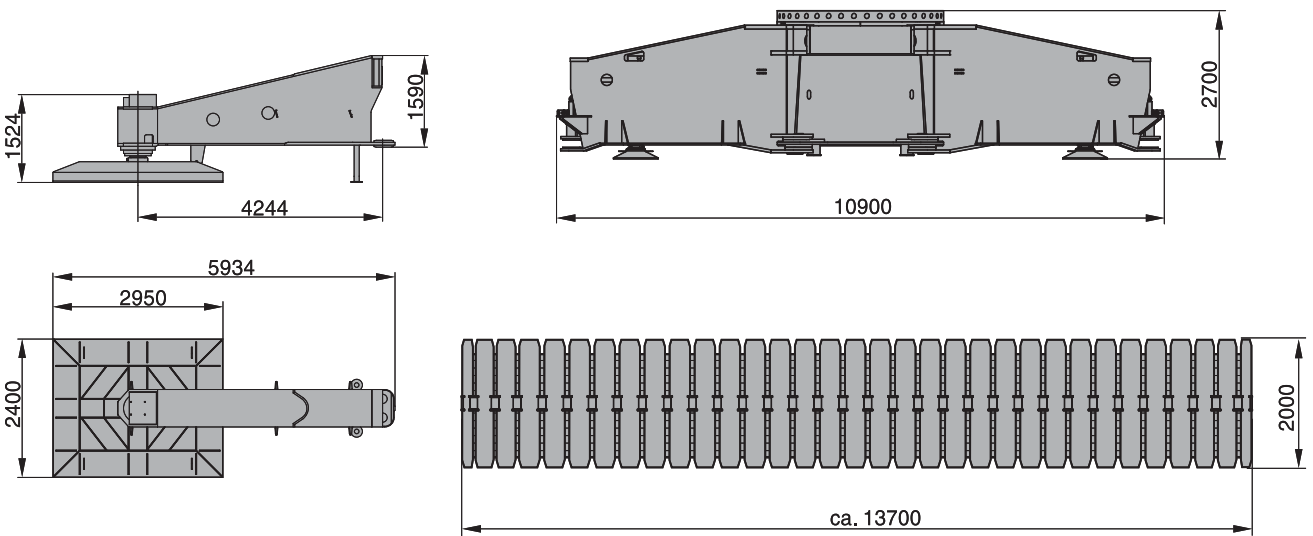
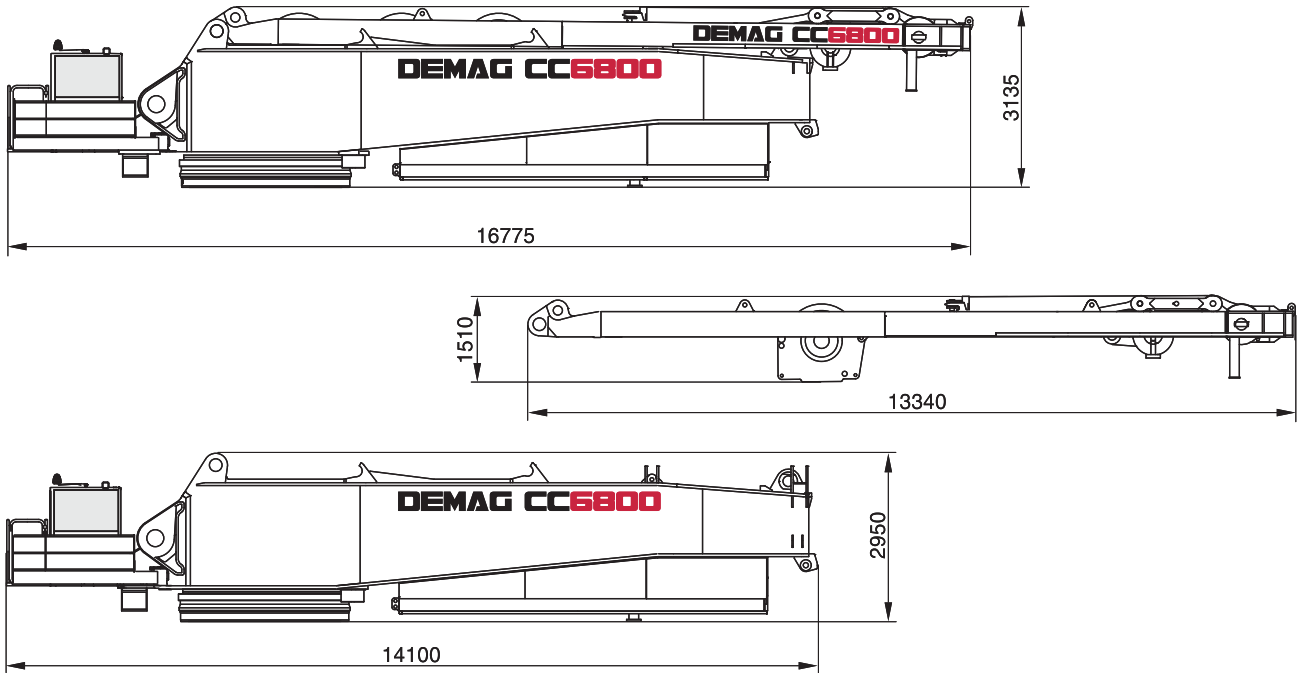

**BOOM COMBINATIONS · AUSLEGER-KOMBINATIONEN · COMBINAISONS DE FLÈCHE**

Typ 3328  
36 - 96 m

SH 96

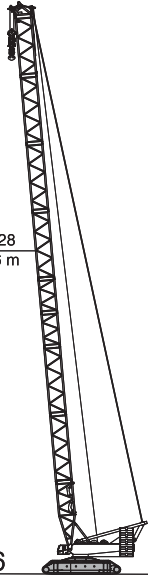

Typ 3328/2822  
48 - 114 m

SH/LH 108  
LH 114

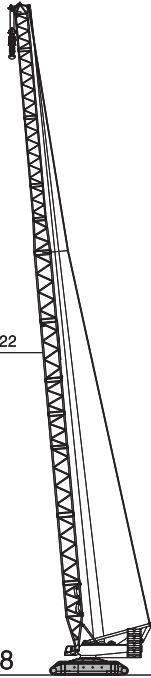

Typ 3328  
42 - 96 m

SSL 96

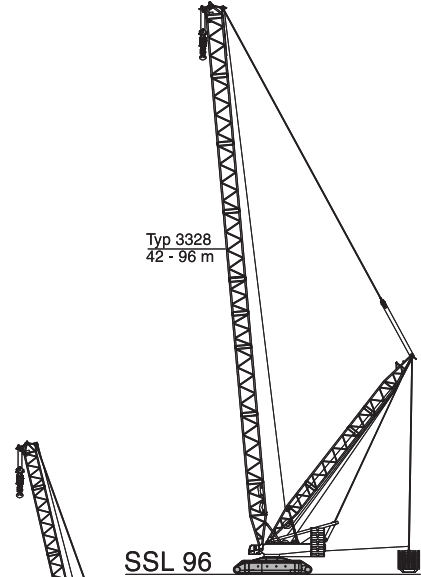

Typ 3328/2822  
102 - 150 m

SSL/LSL 150

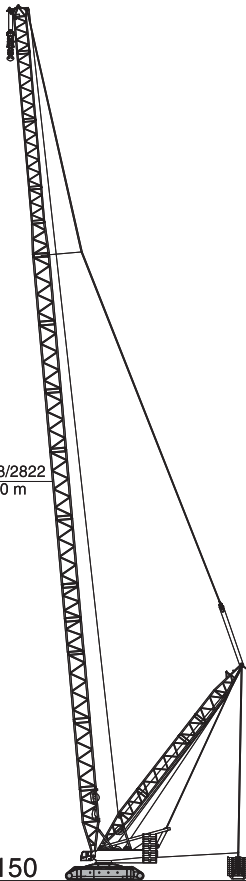

Typ 3328/2822  
30 - 60 m

SW 60+60

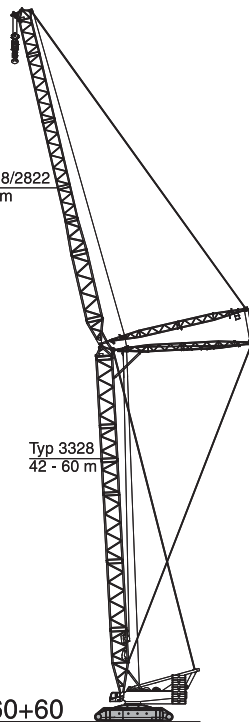

Typ 3328  
42 - 60 m

Typ 3328/2822  
30 - 108 m

SWSL 96+108

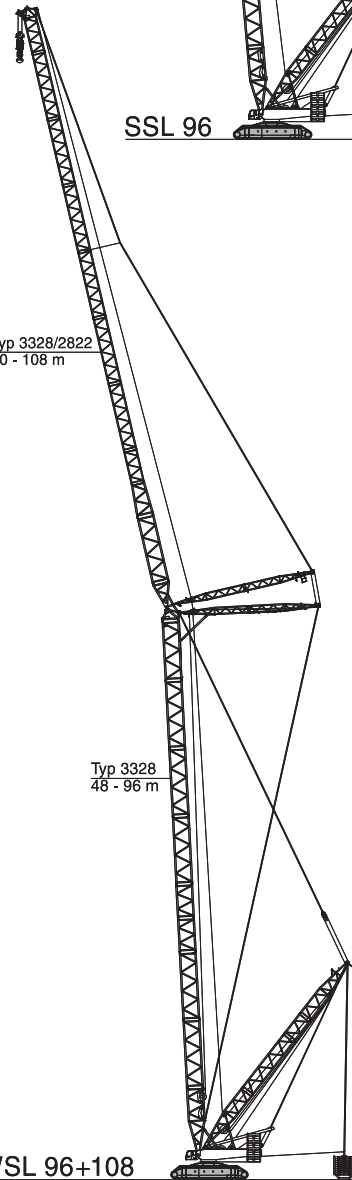

Typ 3328  
48 - 96 m

**BOOM COMBINATIONS · AUSLEGER-KOMBINATIONEN · COMBINAISONS DE FLÛCHE**

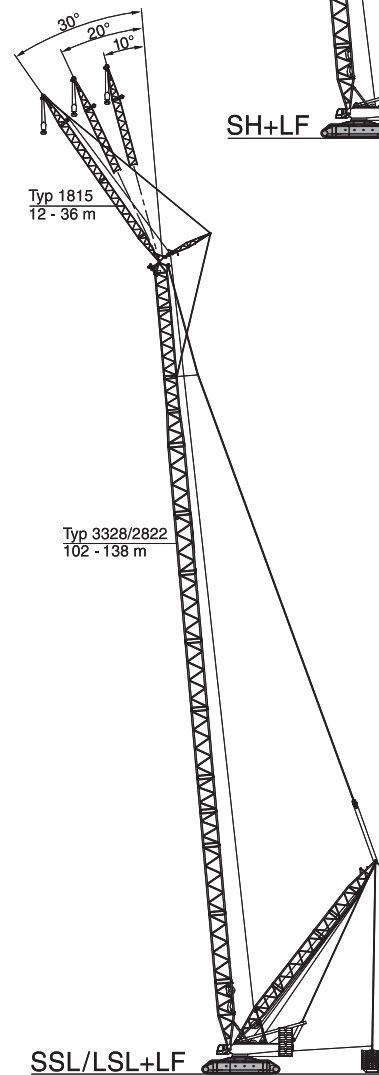
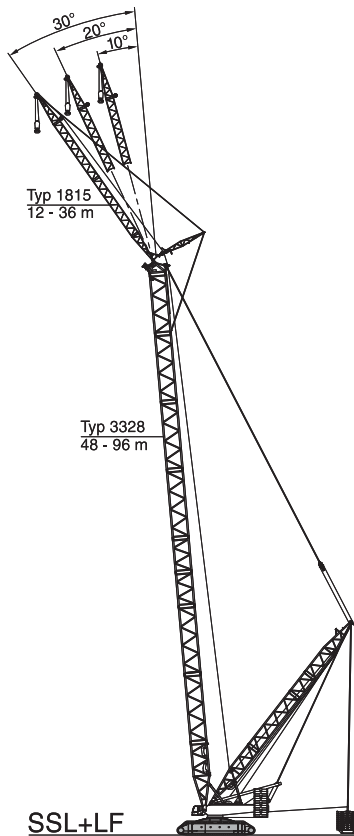
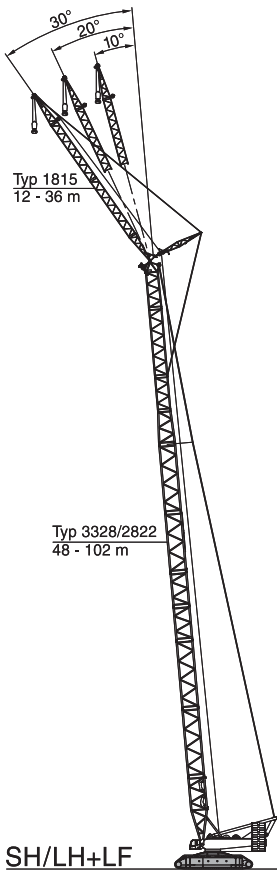
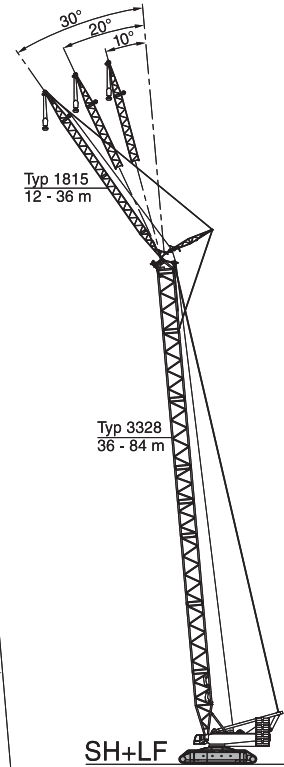
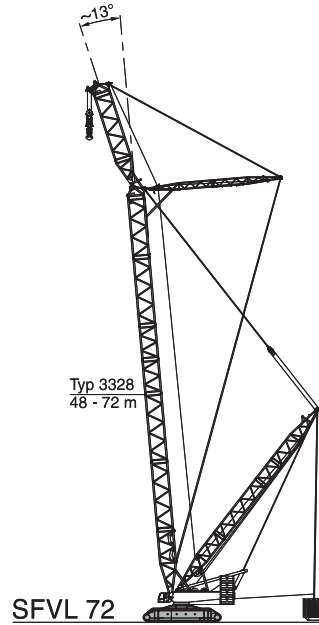
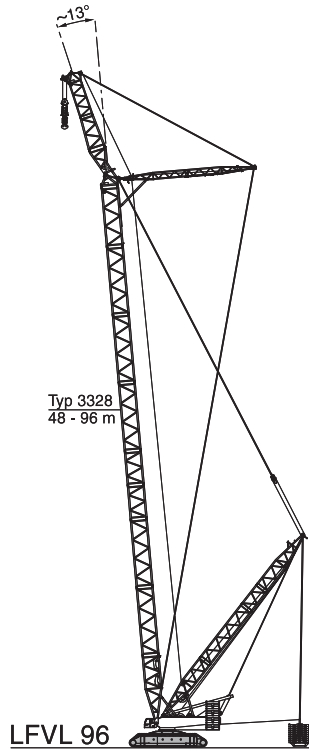

**ERECTION / LOWERING OF THE CC 6800 BOOM SYSTEMS TO THE GROUND  
 AUFRICHTEN / ABLEGEN DER CC 6800 AUSLEGERSYSTEME  
 MONTÉE / PLACEMENT SUR SOL DES SYSTÈMES DE FLÈCHE DE LA CC 6800**

☰ 170-250 t 0-80 t ZB ↔ 15-24 m

Boom combination Auslegervariante Combinaison de flèche	Fly jib Hilfsausleger Fléchette (m)	Main boom · Hauptausleger · Flèche principale														
		m	36	42	48	54	60	66	72	78	84	90	96	102	108	114
<b>SH</b>			X	X	X	X	X	X	X	[X]	[X]	[X]	[X]	-	-	-
<b>SH / LH</b>			-	-	X	X	X	X	X	X	X	X	[X]	[X]	[X]	-
<b>LH</b>			-	-	X	X	X	X	X	X	X	X	X	X	[X]	[X]
<b>SW 87°</b>	30		-	X	X	X	[X]	-	-	-	-	-	-	-	-	-
	36		-	X	X	X	[X]	-	-	-	-	-	-	-	-	-
	42		-	X	X	X	[X]	-	-	-	-	-	-	-	-	-
	48		-	X	X	X	[X]	-	-	-	-	-	-	-	-	-
	54		-	X	X	X	[X]	-	-	-	-	-	-	-	-	-
	60		-	X	X	[X]	[X]	-	-	-	-	-	-	-	-	-
	66		-	X	X	[X]	[X]	-	-	-	-	-	-	-	-	-
	72		-	X	X	[X]	-	-	-	-	-	-	-	-	-	-
	78		-	X	X	[X]	-	-	-	-	-	-	-	-	-	-
	84		-	X	X	[X]	-	-	-	-	-	-	-	-	-	-
	90		-	X	X	[X]	-	-	-	-	-	-	-	-	-	
	96		-	X	X	[X]	-	-	-	-	-	-	-	-	-	

**Remarks · Bemerkungen · Remarques**

X without assisting equipment · ohne Zusatzausrüstung · sans équipement aditionnel

[X] with additional side jack · mit seitlicher Zusatzabstützung · avec support latéral aditionnel

All Superlift combinations can be erected or lowered to the ground without assisting equipment.

Alle Varianten mit Superlift können ohne Zusatzausrüstung aufgerichtet bzw. abgelegt werden.

Montée et dépose sur sol de toutes les combinaisons avec SL sans équipement aditionnel.

**SH, SH/LH, LH** WORKING RANGES · ARBEITSBEREICHE ·  
PORTÉES

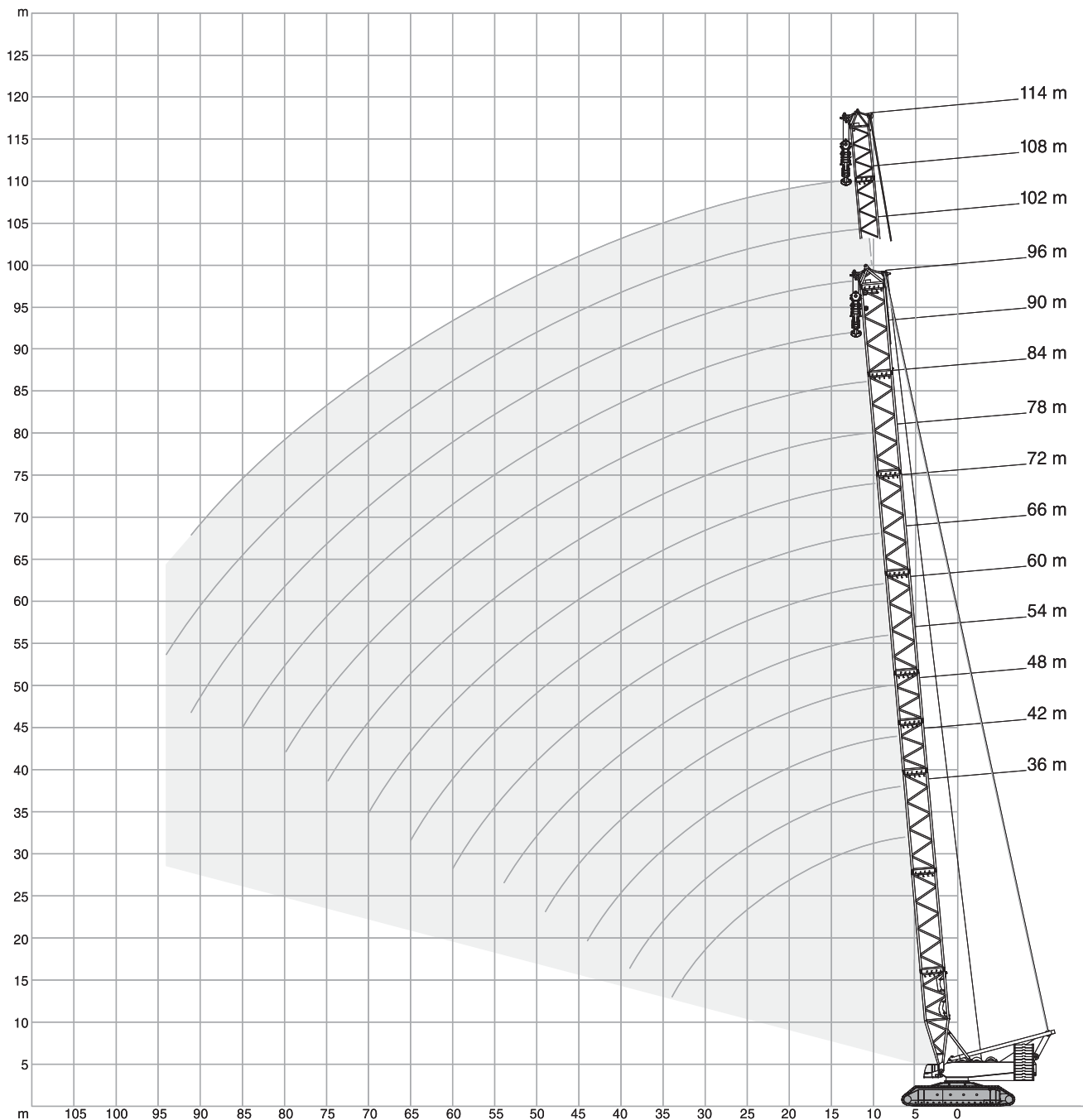

# SH LIFTING CAPACITIES · TRAGFÄHIGKEITEN · CAPACITÉS DE LEVAGE

		170-250 t 0-80 t ZB		9,60 m		360°		ISO					
m	t	36,0 m	42,0 m	48,0 m	54,0 m	60,0 m	66,0 m	72,0 m	78,0 m	84,0 m	90,0 m	96,0 m	m
		t	t	t	t	t	t	t	t	t	t	t	
7	791,0	-	-	-	-	-	-	-	-	-	-	-	7
8	696,0	691,0	681,0	-	-	-	-	-	-	-	-	-	8
9	620,0	616,0	592,0	556,0	-	-	-	-	-	-	-	-	9
10	559,0	554,0	523,0	493,0	466,0	441,0	-	-	-	-	-	-	10
11	507,0	494,0	467,0	442,0	419,0	398,0	378,0	360,0	-	-	-	-	11
12	459,0	444,0	421,0	400,0	380,0	362,0	345,0	329,0	313,0	299,0	-	-	12
13	418,0	403,0	383,0	365,0	348,0	332,0	316,0	302,0	288,0	276,0	250,0	-	13
14	383,0	368,0	351,0	335,0	319,0	306,0	292,0	279,0	266,0	255,0	243,0	-	14
16	322,0	313,0	299,0	286,0	274,0	262,0	251,0	241,0	230,0	220,0	210,0	-	16
18	267,0	265,0	259,0	249,0	238,0	229,0	219,0	210,0	201,0	192,0	184,0	-	18
20	227,0	225,0	223,0	219,0	209,0	201,0	193,0	185,0	177,0	169,0	162,0	-	20
22	197,0	194,0	192,0	190,0	186,0	179,0	171,0	164,0	157,0	150,0	143,0	-	22
24	172,0	170,0	167,0	165,0	163,0	160,0	153,0	147,0	140,0	134,0	127,0	-	24
26	153,0	150,0	148,0	146,0	144,0	142,0	138,0	132,0	126,0	120,0	114,0	-	26
28	137,0	134,0	132,0	129,0	127,0	126,0	124,0	119,0	113,0	108,0	102,0	-	28
30	124,0	121,0	118,0	116,0	114,0	112,0	111,0	108,0	102,0	97,5	92,0	-	30
34	103,0	100,0	97,0	94,5	92,5	91,0	89,0	87,0	84,0	79,5	74,5	-	34
38	-	84,0	81,0	78,5	76,0	74,5	72,0	70,0	67,5	65,5	60,5	-	38
39	-	81,0	77,7	75,2	72,5	70,7	68,5	66,2	63,7	61,7	57,5	-	39
42	-	-	69,0	66,2	63,0	61,0	58,7	56,5	53,6	51,5	48,5	-	42
44	-	-	63,5	60,5	57,0	55,0	52,5	50,5	47,9	45,9	42,6	-	44
46	-	-	-	55,7	52,4	50,3	47,7	45,5	42,9	40,8	37,3	-	46
49	-	-	-	49,4	45,9	43,5	41,0	38,6	35,7	33,7	30,4	-	49
50	-	-	-	-	43,9	41,6	39,0	36,6	33,6	31,7	28,3	-	50
54	-	-	-	-	37,0	34,5	31,5	29,2	26,3	24,1	20,6	-	54
58	-	-	-	-	-	28,6	25,5	22,9	19,8	17,7	14,3	-	58
60	-	-	-	-	-	25,9	22,7	20,1	17,0	14,8	11,4	-	60
62	-	-	-	-	-	-	20,3	17,6	14,5	12,2	8,8	-	62
63	-	-	-	-	-	-	19,1	16,4	13,3	10,9	7,5	-	63
65	-	-	-	-	-	-	17,0	14,1	11,0	8,6	-	-	65
66	-	-	-	-	-	-	-	13,1	10,0	7,5	-	-	66
68	-	-	-	-	-	-	-	11,1	7,9	-	-	-	68
70	-	-	-	-	-	-	-	9,3	-	-	-	-	70

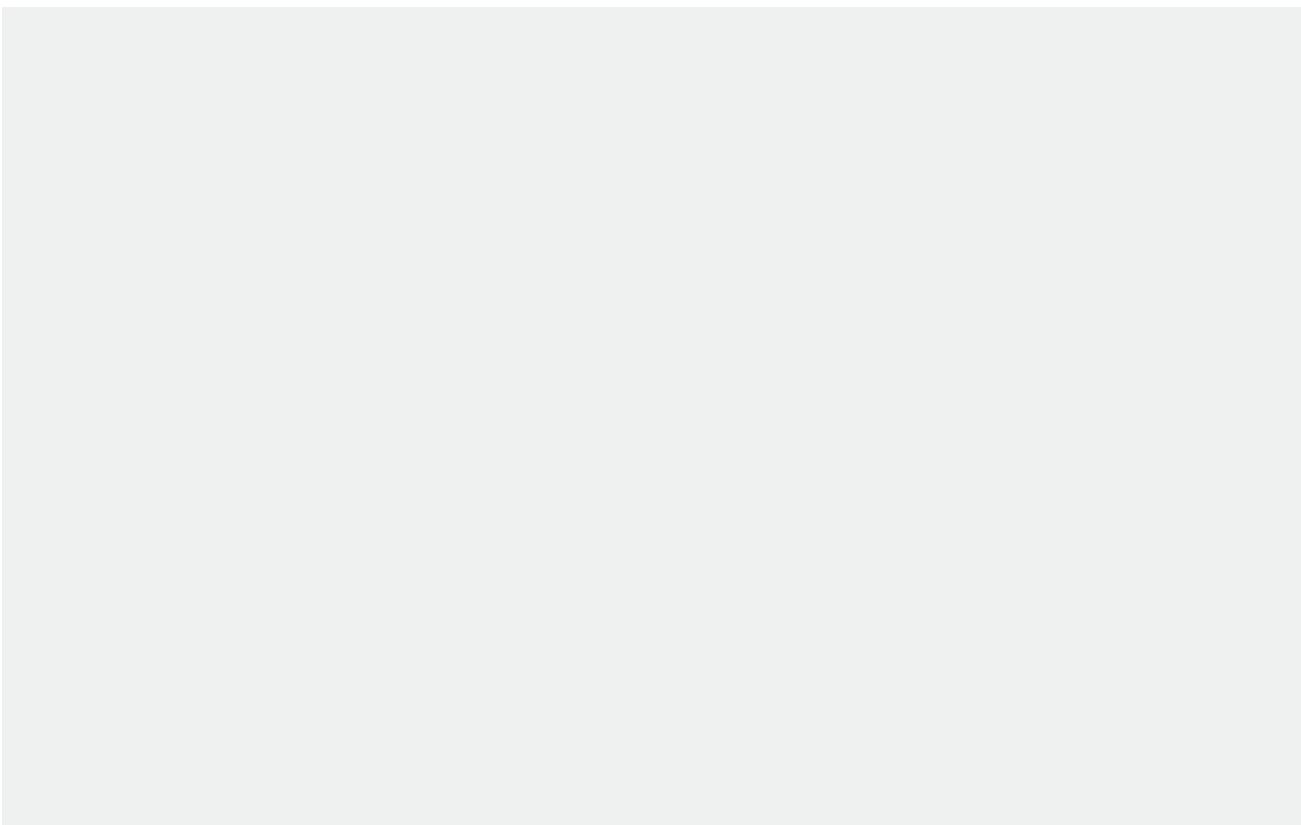



**SH/ LH LIFTING CAPACITIES · TRAGFÄHIGKEITEN · CAPACITÉS DE LEVAGE**

170-250 t 0-80 t ZB 9,60 m 360° ISO

m	Lifting Capacity (t)												m
	48,0 m	54,0 m	60,0 m	66,0 m	72,0 m	78,0 m	84,0 m	90,0 m	96,0 m	102,0 m	108,0 m		
8	506,0	-	-	-	-	-	-	-	-	-	-	-	8
9	506,0	506,0	506,0	-	-	-	-	-	-	-	-	-	9
10	506,0	501,0	474,0	451,0	429,0	-	-	-	-	-	-	-	10
11	468,0	455,0	431,5	412,0	393,0	373,0	357,0	-	-	-	-	-	11
12	430,0	409,0	389,0	373,0	357,0	342,0	328,0	315,0	300,0	-	-	-	12
13	395,0	376,5	359,0	344,5	330,5	317,5	305,0	293,0	279,5	268,0	242,0	-	13
14	360,0	344,0	329,0	316,0	304,0	293,0	282,0	271,0	259,0	250,0	241,0	-	14
16	309,0	296,0	283,0	274,0	263,0	254,0	245,0	237,0	226,0	219,0	212,0	-	16
18	269,0	258,0	248,0	240,0	232,0	224,0	217,0	210,0	200,0	194,0	188,0	-	18
20	231,0	229,0	220,0	213,0	206,0	199,0	193,0	187,0	178,0	173,0	168,0	-	20
22	203,5	201,5	196,0	192,5	186,5	180,5	175,0	169,5	161,5	156,5	152,0	-	22
24	176,0	174,0	172,0	172,0	167,0	162,0	157,0	152,0	145,0	140,0	136,0	-	24
26	158,5	156,0	154,0	154,0	151,5	148,0	143,5	139,0	132,5	128,0	124,5	-	26
28	141,0	138,0	136,0	136,0	136,0	134,0	130,0	126,0	120,0	116,0	113,0	-	28
30	128,5	125,5	123,5	123,5	123,0	122,0	119,5	116,0	110,0	106,7	104,0	-	30
34	106,7	103,7	101,7	101,5	100,7	100,5	99,5	97,7	92,5	90,0	87,5	-	34
38	90,5	87,5	85,2	85,0	84,2	83,7	82,7	82,2	78,2	76,2	74,0	-	38
42	78,2	75,3	72,6	72,5	71,5	71,0	70,0	69,3	65,6	64,1	62,5	-	42
44	73,0	70,1	67,3	67,0	66,0	65,5	64,5	63,6	59,8	58,3	57,0	-	44
46	-	65,0	62,0	61,5	60,5	60,0	59,0	58,0	54,0	52,5	51,5	-	46
49	-	59,0	56,2	55,5	54,4	53,6	52,5	51,6	47,5	46,0	44,9	-	49
50	-	-	54,3	53,5	52,3	51,5	50,3	49,5	45,3	43,9	42,7	-	50
54	-	-	47,3	46,5	45,1	44,0	42,7	41,9	37,5	36,2	35,3	-	54
58	-	-	-	40,3	38,7	37,5	36,2	35,3	31,0	29,6	28,6	-	58
59	-	-	-	39,0	37,4	36,1	34,7	34,0	29,6	28,1	27,2	-	59
62	-	-	-	-	33,6	32,3	30,9	30,1	25,5	24,2	23,2	-	62
65	-	-	-	-	30,3	28,9	27,3	26,4	22,0	20,5	19,5	-	65
66	-	-	-	-	-	27,9	26,3	25,3	21,0	19,5	18,4	-	66
70	-	-	-	-	-	24,1	22,3	21,2	16,8	15,3	14,2	-	70
74	-	-	-	-	-	-	19,0	17,8	13,3	11,8	10,7	-	74
75	-	-	-	-	-	-	18,2	17,0	12,5	10,9	9,8	-	75
78	-	-	-	-	-	-	-	14,8	10,3	8,6	7,5	-	78
80	-	-	-	-	-	-	-	13,4	8,9	7,2	6,1	-	80
81	-	-	-	-	-	-	-	-	8,2	6,5	5,4	-	81
82	-	-	-	-	-	-	-	-	7,5	5,8	-	-	82
83	-	-	-	-	-	-	-	-	6,9	5,2	-	-	83
85	-	-	-	-	-	-	-	-	5,7	-	-	-	85

2

# LH LIFTING CAPACITIES · TRAGFÄHIGKEITEN · CAPACITÉS DE LEVAGE

		170-250 t 0-80 t ZB											9,60 m		360°		ISO	
		42,0 m 48,0 m 54,0 m 60,0 m 66,0 m 72,0 m 78,0 m 84,0 m 90,0 m 96,0 m 102,0 m 108,0 m 114,0 m																
		t t t t t t t t t t t t t t																
		m t t t t t t t t t t t t t m																
8		506,0	506,0	-	-	-	-	-	-	-	-	-	-	-	-	-	-	8
9		506,0	506,0	506,0	493,0	-	-	-	-	-	-	-	-	-	-	-	-	9
10		506,0	506,0	505,0	480,0	431,0	361,0	-	-	-	-	-	-	-	-	-	-	10
11		480,0	469,5	459,0	438,0	405,0	355,0	313,0	260,0	-	-	-	-	-	-	-	-	11
12		454,0	433,0	413,0	396,0	379,0	349,0	313,0	260,0	230,0	194,0	-	-	-	-	-	-	12
13		416,0	398,0	381,0	365,5	350,5	329,5	305,5	257,5	228,0	194,0	172,0	143,0	-	-	-	-	13
14		378,0	363,0	349,0	335,0	322,0	310,0	298,0	255,0	226,0	194,0	172,0	143,0	123,0	-	-	-	14
16		323,0	312,0	301,0	290,0	280,0	270,0	260,0	246,0	219,0	188,0	170,0	141,0	123,0	-	-	-	16
18		275,0	273,0	263,0	255,0	246,0	239,0	230,0	223,0	211,0	183,0	166,0	138,0	120,0	-	-	-	18
20		235,0	234,0	233,0	227,0	220,0	213,0	205,0	200,0	193,0	177,0	162,0	134,0	117,0	-	-	-	20
22		207,5	206,5	205,5	202,5	199,0	193,5	186,5	182,0	176,0	166,0	156,0	130,5	113,5	-	-	-	22
24		180,0	179,0	178,0	178,0	178,0	174,0	168,0	164,0	159,0	155,0	150,0	127,0	110,0	-	-	-	24
26		162,0	161,5	160,0	160,0	160,0	157,5	154,0	150,5	146,0	142,5	138,0	124,5	107,5	-	-	-	26
28		144,0	144,0	142,0	142,0	142,0	141,0	140,0	137,0	133,0	130,0	126,0	122,0	105,0	-	-	-	28
30		131,5	131,5	129,5	129,5	129,0	128,5	127,5	125,5	123,0	120,5	116,5	113,0	102,5	-	-	-	30
34		110,0	109,5	108,0	107,7	107,0	106,7	105,5	105,0	104,0	102,5	99,7	97,0	93,5	-	-	-	34
38		94,3	93,2	92,0	91,5	90,7	90,2	88,7	88,7	87,7	86,7	85,2	83,7	81,2	-	-	-	38
39		91,0	89,8	88,5	88,0	87,1	86,6	85,1	85,1	84,1	83,1	81,6	80,6	78,3	-	-	-	39
42		-	81,2	79,8	79,1	78,1	77,6	76,0	76,0	75,0	74,0	72,5	72,0	70,0	-	-	-	42
44		-	76,0	74,6	73,8	72,8	72,3	70,5	70,5	69,5	68,5	67,0	66,5	64,5	-	-	-	44
46		-	-	69,5	68,5	67,5	67,0	65,0	65,0	64,0	63,0	61,5	61,0	59,0	-	-	-	46
49		-	-	63,5	62,7	61,5	61,0	59,0	59,0	57,7	56,7	55,2	54,5	52,6	-	-	-	49
50		-	-	-	60,8	59,5	59,0	57,0	57,0	55,6	54,6	53,1	52,3	50,4	-	-	-	50
54		-	-	-	54,0	52,7	52,0	49,9	49,7	48,3	47,3	45,6	44,6	42,8	-	-	-	54
58		-	-	-	-	47,1	46,0	43,8	43,3	42,0	40,9	39,0	38,0	36,1	-	-	-	58
59		-	-	-	-	45,8	44,7	42,5	42,0	40,7	39,6	37,6	36,6	34,7	-	-	-	59
62		-	-	-	-	-	41,1	38,7	38,1	36,8	35,7	33,6	32,5	30,8	-	-	-	62
65		-	-	-	-	-	37,7	35,2	34,5	33,1	31,9	30,1	29,0	27,0	-	-	-	65
66		-	-	-	-	-	-	34,2	33,5	32,0	30,8	29,0	27,9	25,9	-	-	-	66
70		-	-	-	-	-	-	30,4	29,5	28,0	26,8	24,8	23,7	21,8	-	-	-	70
74		-	-	-	-	-	-	-	26,2	24,6	23,3	21,3	20,3	18,3	-	-	-	74
75		-	-	-	-	-	-	-	25,4	23,8	22,5	20,5	19,4	17,4	-	-	-	75
78		-	-	-	-	-	-	-	-	21,5	20,3	18,3	17,1	15,1	-	-	-	78
80		-	-	-	-	-	-	-	-	20,2	18,9	16,9	15,7	13,6	-	-	-	80
82		-	-	-	-	-	-	-	-	-	17,6	15,5	14,3	12,3	-	-	-	82
85		-	-	-	-	-	-	-	-	-	15,8	13,7	12,4	10,5	-	-	-	85
86		-	-	-	-	-	-	-	-	-	-	13,1	11,9	9,9	-	-	-	86
90		-	-	-	-	-	-	-	-	-	-	11,0	9,8	7,7	-	-	-	90
91		-	-	-	-	-	-	-	-	-	-	10,6	9,3	7,2	-	-	-	91
94		-	-	-	-	-	-	-	-	-	-	-	7,9	5,7	-	-	-	94
95		-	-	-	-	-	-	-	-	-	-	-	7,4	5,3	-	-	-	95
96		-	-	-	-	-	-	-	-	-	-	-	7,0	-	-	-	-	96
98		-	-	-	-	-	-	-	-	-	-	-	-	-	-	-	-	98

**SSL, SSL/LSL** WORKING RANGES · ARBEITSBEREICHE · PORTÉES

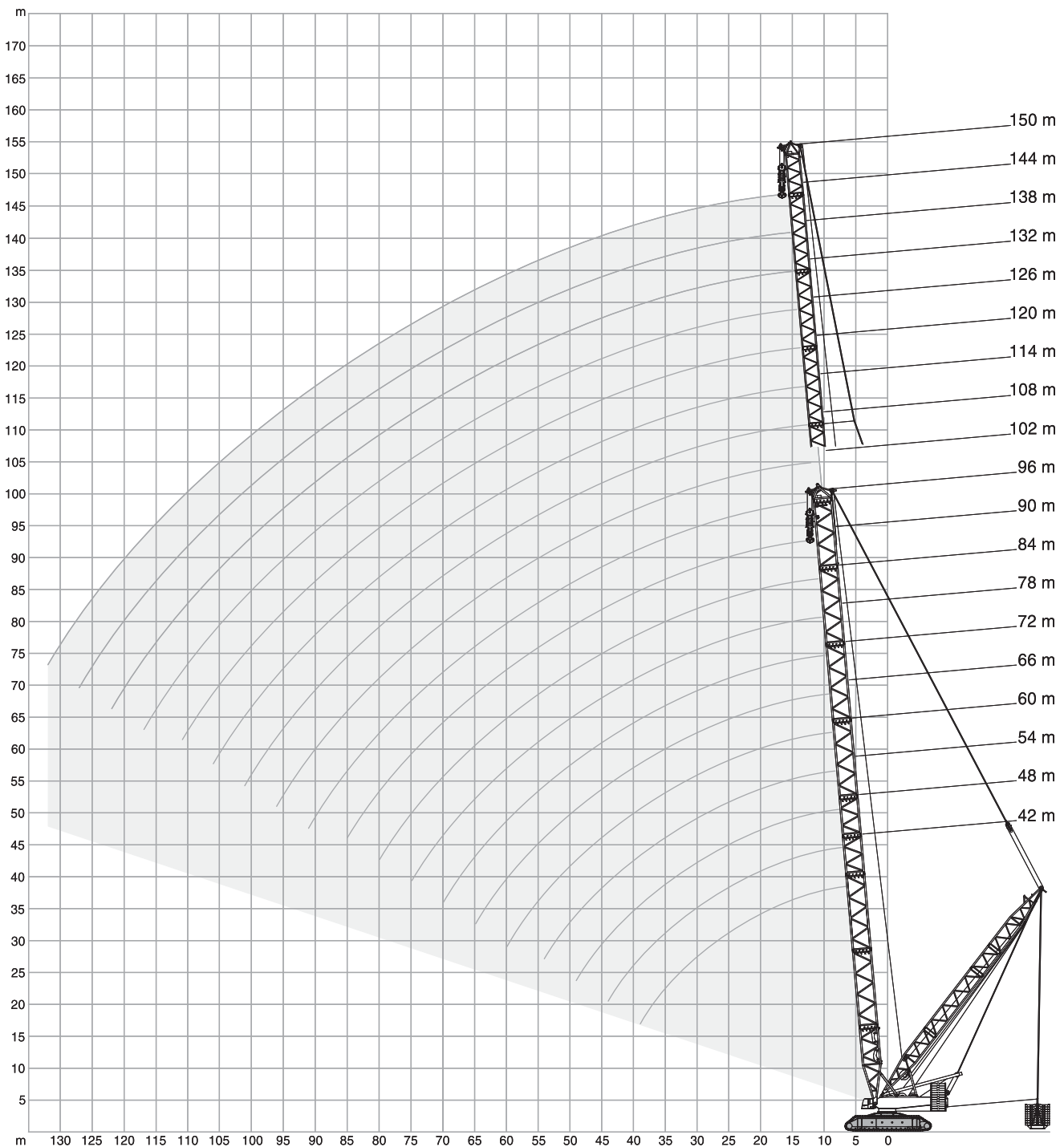

**SSL LIFTING CAPACITIES · TRAGFÄHIGKEITEN · CAPACITÉS DE LEVAGE**
 170-250 t  
  0-80 t ZB  
  15-24 m  
  9,60 m  
 360°  
  ISO

m	42 m		48 m		54 m		60 m		66 m		m		
	0 t		80t-450t		0 t		80t-450t		0 t			80t-450t	
	t	t	t	t	t	t	t	t	t	t			
8	761,0	1250,0	757,0	1186,0	-	-	-	-	-	-	8		
9	678,0	1246,0	674,0	1186,0	645,0	1037,0	-	-	-	-	9		
10	602,0	1243,0	602,0	1186,0	573,0	1037,0	542,0	959,0	514,0	841,0	10		
12	470,0	1127,0	468,0	1123,0	467,0	1037,0	445,0	959,0	424,0	841,0	12		
14	382,0	988,0	379,0	984,0	378,0	981,0	375,0	959,0	359,0	841,0	14		
16	329,0	865,0	316,0	861,0	314,0	858,0	313,0	855,0	310,0	841,0	16		
18	281,0	768,0	278,0	764,0	267,0	761,0	266,0	758,0	265,0	756,0	18		
20	244,0	690,0	241,0	686,0	239,0	683,0	229,0	680,0	228,0	678,0	20		
22	214,0	625,0	211,0	622,0	209,0	619,0	207,0	616,0	206,0	613,0	22		
24	190,0	568,0	187,0	568,0	184,0	565,0	182,0	562,0	181,0	560,0	24		
26	170,0	505,0	167,0	522,0	164,0	519,0	162,0	516,0	160,0	514,0	26		
28	153,0	451,0	150,0	483,0	147,0	480,0	144,0	477,0	143,0	474,0	28		
30	139,0	416,0	135,0	447,0	132,0	446,0	130,0	442,0	128,0	440,0	30		
34	115,0	340,0	112,0	368,0	109,0	389,0	106,0	386,0	104,0	384,0	34		
38	98,0	285,0	94,0	315,0	91,0	334,0	88,0	341,0	86,0	339,0	38		
39	94,0	269,0	90,2	301,0	87,2	320,0	84,0	331,5	82,0	329,5	39		
42	-	-	80,2	261,0	77,0	281,5	73,5	301,0	71,5	303,5	42		
44	-	-	74,0	237,0	70,5	262,0	67,0	280,0	65,0	287,0	44		
46	-	-	-	-	65,2	243,5	61,7	259,5	59,5	272,0	46		
49	-	-	-	-	58,0	214,0	54,3	229,7	51,8	248,2	49		
50	-	-	-	-	-	-	52,2	223,0	49,7	239,5	50		
54	-	-	-	-	-	-	44,1	195,0	41,6	206,0	54		
58	-	-	-	-	-	-	-	-	34,7	180,5	58		
60	-	-	-	-	-	-	-	-	31,6	170,0	60		
64	-	-	-	-	-	-	-	-	-	-	64		

m	72 m		78 m		84 m		90 m		96 m		m		
	0 t		80t-450t		0 t		80t-450t		0 t			80t-450t	
	t	t	t	t	t	t	t	t	t	t			
11	443,0	760,0	422,0	677,0	-	-	-	-	-	-	11		
12	404,0	760,0	387,0	677,0	369,0	625,0	353,0	559,0	-	-	12		
13	372,0	760,0	356,0	677,0	340,0	625,0	326,0	559,0	312,0	498,0	13		
14	343,0	760,0	329,0	677,0	315,0	625,0	302,0	559,0	289,0	498,0	14		
16	297,0	760,0	285,0	677,0	273,0	625,0	263,0	559,0	252,0	498,0	16		
18	260,0	749,0	250,0	677,0	240,0	616,0	231,0	559,0	221,0	498,0	18		
20	227,0	675,0	222,0	666,0	213,0	604,0	205,0	550,0	196,0	498,0	20		
22	197,0	611,0	196,0	608,0	190,0	595,0	183,0	539,0	175,0	490,0	22		
24	180,0	557,0	172,0	554,0	170,0	551,0	164,0	535,0	157,0	482,0	24		
26	159,0	511,0	157,0	509,0	149,0	505,0	148,0	503,0	142,0	478,0	26		
28	141,0	472,0	140,0	469,0	137,0	466,0	130,0	464,0	127,0	460,0	28		
30	126,0	437,0	124,0	435,0	122,0	432,0	120,0	429,0	116,0	426,0	30		
34	102,0	381,0	100,0	378,0	97,5	375,0	96,0	373,0	92,5	369,0	34		
38	83,5	336,0	81,5	333,0	78,5	330,0	77,0	328,0	73,0	324,0	38		
42	69,2	300,5	66,7	297,5	63,7	294,5	61,7	292,5	58,2	288,5	42		
46	57,0	270,0	54,6	267,5	51,6	264,0	49,5	262,0	45,9	258,0	46		
50	47,0	244,0	44,6	242,0	41,5	238,5	39,3	236,5	35,6	232,5	50		
54	38,6	218,5	36,1	219,5	32,9	217,0	30,6	215,0	26,9	211,0	54		
58	31,5	191,5	28,8	199,0	25,6	198,0	23,2	196,0	19,5	192,0	58		
62	25,4	166,0	22,6	177,0	19,3	181,0	16,8	179,5	13,1	175,5	62		
65	21,4	155,0	18,5	160,0	15,1	168,0	12,6	168,5	8,8	164,5	65		
66	-	-	17,3	154,3	13,9	163,0	11,3	165,0	7,5	161,0	66		
69	-	-	13,8	142,0	10,3	148,0	7,6	154,0	-	152,0	69		
70	-	-	12,7	139,0	9,2	143,0	-	149,6	-	149,0	70		
72	-	-	-	-	7,0	133,0	-	141,0	-	143,0	72		
74	-	-	-	-	-	126,3	-	132,5	-	135,5	74		
75	-	-	-	-	-	124,0	-	128,2	-	131,7	75		
78	-	-	-	-	-	-	-	115,5	-	120,5	78		
80	-	-	-	-	-	-	-	111,0	-	113,0	80		
82	-	-	-	-	-	-	-	-	-	106,0	82		
85	-	-	-	-	-	-	-	-	-	98,0	85		

**Remarks · Bemerkungen · Remarques**

Duties &gt; 1000 t only with special equipment · Werte &gt; 1000 t nur mit Sonderausrüstung · Capacités de levage &gt; 1000 t uniquement avec équipement special

**SSL/LSL LIFTING CAPACITIES · TRAGFÄHIGKEITEN · CAPACITÉS DE LEVAGE**

170-250 t 0-80 t ZB 15-24 m 9,60 m 360° ISO

m	102 m		108 m		114 m		120 m		126 m		m
	0 t	80t-450t	0 t	80t-450t	0 t	80t-450t	0 t	80t-450t	0 t	80t-450t	
	t	t	t	t	t	t	t	t	t	t	
13	308,0	450,0	294,0	405,0	-	-	-	-	-	-	13
14	288,0	450,0	275,0	405,0	265,0	364,0	256,0	330,0	-	-	14
15	268,0	450,0	256,0	405,0	248,0	364,0	239,0	330,0	231,0	296,0	15
16	252,0	450,0	241,0	405,0	233,5	364,0	225,0	330,0	218,0	296,0	16
18	223,0	450,0	213,0	405,0	207,0	364,0	199,5	330,0	193,5	296,0	18
20	199,0	450,0	189,5	405,0	184,5	364,0	178,0	330,0	173,0	296,0	20
22	179,0	442,3	170,3	405,0	165,6	364,0	160,0	330,0	156,0	296,0	22
24	161,0	441,0	153,0	405,0	149,0	364,0	144,0	330,0	140,0	296,0	24
26	147,0	433,0	139,5	394,0	136,0	359,0	131,5	329,0	127,5	296,0	26
28	133,0	432,0	126,0	394,0	123,0	359,0	119,0	328,0	115,0	296,0	28
30	122,0	417,5	114,0	389,0	112,0	355,0	109,0	325,0	105,5	293,5	30
34	100,2	378,0	93,5	368,5	92,5	347,5	88,5	317,5	86,2	288,0	34
38	81,2	332,5	76,5	328,0	75,5	326,0	71,5	311,0	70,2	282,0	38
42	66,5	296,3	61,6	292,3	60,5	291,0	58,6	289,0	57,5	268,6	42
46	53,5	265,0	48,8	261,0	47,7	259,0	45,8	257,0	44,5	256,0	46
50	43,7	240,3	39,0	236,3	37,9	235,0	35,9	233,0	34,6	231,3	50
54	34,9	218,3	30,2	214,3	29,1	213,3	27,1	211,3	25,8	209,3	54
58	27,3	199,0	22,6	195,0	21,5	194,0	19,5	192,0	18,2	190,0	58
62	21,2	183,0	16,4	179,0	15,3	178,0	13,3	176,0	12,0	174,0	62
66	15,7	168,3	10,9	164,3	9,7	163,2	7,7	161,0	6,2	160,0	66
68	13,2	161,6	8,4	157,6	7,1	156,4	5,1	154,0	-	153,5	68
69	12,0	158,3	7,2	154,3	5,9	153,0	-	151,0	-	150,2	69
70	10,8	155,0	6,0	151,0	-	150,0	-	148,0	-	147,0	70
74	6,6	143,8	-	140,3	-	139,3	-	137,3	-	135,6	74
75	5,6	141,0	-	137,6	-	136,6	-	134,6	-	132,8	75
78	-	132,3	-	130,0	-	129,3	-	127,3	-	125,3	78
82	-	121,0	-	120,0	-	120,0	-	118,0	-	116,0	82
86	-	108,3	-	108,6	-	111,3	-	109,3	-	108,0	86
90	-	95,6	-	97,5	-	101,6	-	101,0	-	100,6	90
91	-	94,0	-	94,7	-	99,0	-	99,0	-	98,9	91
94	-	-	-	86,5	-	91,0	-	93,0	-	93,5	94
96	-	-	-	83,0	-	86,0	-	88,2	-	89,5	96
98	-	-	-	-	-	81,0	-	83,6	-	85,5	98
101	-	-	-	-	-	75,0	-	76,7	-	79,4	101
102	-	-	-	-	-	-	-	74,5	-	77,3	102
106	-	-	-	-	-	-	-	67,5	-	69,0	106
110	-	-	-	-	-	-	-	-	-	61,6	110
111	-	-	-	-	-	-	-	-	-	60,5	111
114	-	-	-	-	-	-	-	-	-	-	114

2

## SSL/LSL LIFTING CAPACITIES · TRAGFÄHIGKEITEN · CAPACITÉS DE LEVAGE

170-250 t		0-80 t ZB		15-24 m		9,60 m		360°		ISO
m	132 m		138 m		144 m		150 m		m	
	0 t	80t-450t	0 t	80t-450t	0 t	80t-450t	0 t	80t-450t		
15	225,0	266,0	-	-	-	-	-	-	15	
16	212,0	266,0	205,0	239,0	-	-	-	-	16	
17	199,0	266,0	193,0	239,0	187,0	209,0	171,0	184,0	17	
18	188,5	266,0	182,5	239,0	177,0	208,5	163,0	183,5	18	
20	168,5	266,0	163,0	238,5	158,5	207,5	154,0	182,0	20	
22	151,3	266,0	146,6	238,0	143,0	206,0	139,0	180,0	22	
24	136,0	266,0	132,0	238,0	129,0	204,0	125,0	178,0	24	
26	124,0	266,0	120,5	237,5	117,5	202,5	114,0	176,0	26	
28	112,0	266,0	109,0	237,0	106,0	201,0	103,0	174,0	28	
30	102,7	265,5	99,7	235,5	97,2	199,0	94,2	172,0	30	
34	84,7	262,5	82,5	232,0	81,0	194,5	78,2	167,0	34	
38	69,5	254,5	66,2	224,0	65,2	189,0	63,2	161,0	38	
42	56,6	245,6	52,7	215,0	51,8	183,3	50,3	155,0	42	
46	43,8	235,0	42,3	206,0	41,6	178,0	40,0	149,0	46	
50	33,9	223,6	32,4	198,6	31,6	166,6	30,0	144,2	50	
54	25,1	208,3	23,6	193,3	22,8	159,0	21,2	136,6	54	
58	17,4	189,0	15,9	188,0	15,1	153,0	13,5	130,0	58	
62	11,2	173,6	9,7	172,0	8,9	148,2	7,1	125,6	62	
63	9,7	169,8	8,2	168,0	7,4	147,0	5,6	124,3	63	
64	8,2	166,0	6,7	164,0	5,9	145,0	-	123,0	64	
65	6,8	162,5	5,3	160,0	-	142,8	-	120,8	65	
66	5,5	159,0	-	156,8	-	141,6	-	118,6	66	
70	-	146,0	-	144,0	-	137,0	-	114,0	70	
74	-	135,3	-	133,3	-	130,3	-	109,3	74	
78	-	125,0	-	123,3	-	122,3	-	104,6	78	
82	-	115,0	-	114,0	-	113,0	-	100,0	82	
86	-	107,0	-	106,0	-	105,0	-	96,8	86	
90	-	99,5	-	98,0	-	97,2	-	93,1	90	
94	-	93,0	-	91,0	-	90,0	-	88,5	94	
98	-	86,3	-	85,0	-	84,0	-	82,1	98	
102	-	79,1	-	78,8	-	78,3	-	76,3	102	
106	-	71,5	-	72,5	-	73,0	-	71,0	106	
110	-	64,1	-	65,5	-	66,3	-	65,6	110	
114	-	56,9	-	58,6	-	60,0	-	60,0	114	
117	-	53,5	-	53,6	-	55,5	-	55,5	117	
118	-	-	-	52,0	-	54,0	-	54,0	118	
122	-	-	-	47,6	-	48,0	-	48,6	122	
126	-	-	-	-	-	43,2	-	43,2	126	
127	-	-	-	-	-	42,5	-	41,9	127	
130	-	-	-	-	-	-	-	38,4	130	
132	-	-	-	-	-	-	-	37,0	132	

**SW** WORKING RANGES · ARBEITSBEREICHE · PORTÉES

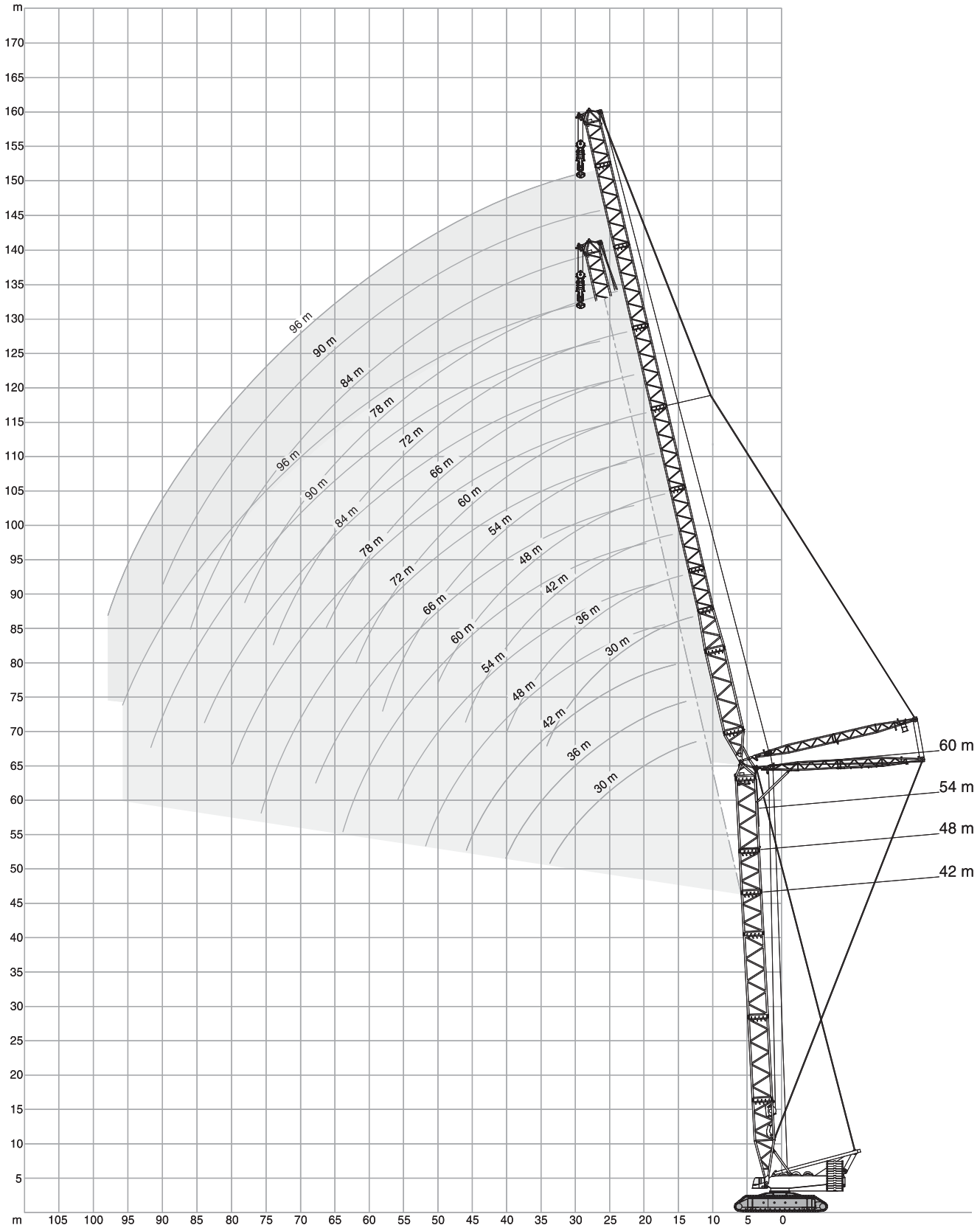

# SW LIFTING CAPACITIES · TRAGFÄHIGKEITEN · CAPACITÉS DE LEVAGE

170-250 t 0-80 t ZB 9,60 m 360° ISO

42 m

m	30 m			36 m			42 m			48 m			54 m			60 m		
	87°	75°	65°	87°	75°	65°	87°	75°	65°	87°	75°	65°	87°	75°	65°	87°	75°	65°
14	339,0	-	-	-	-	-	-	-	-	-	-	-	-	-	-	-	-	-
15	317,0	-	-	305,0	-	-	-	-	-	-	-	-	-	-	-	-	-	-
16	297,0	-	-	286,0	-	-	277,0	-	-	-	-	-	-	-	-	-	-	-
18	265,0	-	-	256,0	-	-	247,0	-	-	239,0	-	-	-	-	-	-	-	-
19	251,0	-	-	242,0	-	-	235,0	-	-	227,0	-	-	220,0	-	-	-	-	-
20	238,0	-	-	230,0	-	-	223,0	-	-	216,0	-	-	209,0	-	-	202,0	-	-
22	217,0	-	-	209,0	-	-	203,0	-	-	197,0	-	-	191,0	-	-	184,0	-	-
24	198,0	-	-	192,0	-	-	186,0	-	-	180,0	-	-	175,0	-	-	169,0	-	-
26	183,0	-	-	177,0	-	-	172,0	-	-	166,0	-	-	161,0	-	-	156,0	-	-
28	166,0	145,0	-	164,0	-	-	159,0	-	-	154,0	-	-	150,0	-	-	145,0	-	-
30	151,0	132,0	-	151,0	-	-	148,0	-	-	143,0	-	-	139,0	-	-	135,0	-	-
32	138,0	120,0	-	138,0	119,0	-	138,0	-	-	134,0	-	-	130,0	-	-	126,0	-	-
34	127,0	111,0	-	127,0	110,0	-	127,0	109,0	-	125,0	-	-	122,0	-	-	118,0	-	-
36	-	102,0	-	118,0	101,0	-	117,0	100,0	-	116,0	98,5	-	114,0	-	-	111,0	-	-
38	-	95,0	-	109,0	94,0	-	109,0	93,5	-	107,0	91,0	-	107,0	89,5	-	104,0	-	-
40	-	88,5	77,5	99,5*	87,5	-	102,0	87,0	-	100,0	84,5	-	99,5	84,0	-	98,5	-	-
42	-	83,0	72,0	-	82,0	-	95,0	81,0	-	93,5	79,0	-	93,0	78,0	-	93,0	76,0	-
44	-	-	67,5	-	76,5	66,0	89,5	76,0	-	88,0	74,0	-	87,0	73,0	-	87,0	71,5	-
46	-	-	63,5	-	72,0	62,0	82,0*	71,0	-	82,5	69,0	-	82,0	68,5	-	81,5	67,5	-
48	-	-	59,5	-	68,0	58,5	-	67,0	57,0	77,5	65,0	-	77,0	64,0	-	77,0	63,5	-
50	-	-	56,0	-	-	55,0	-	63,0	53,5	73,5	61,0	51,0	72,5	60,5	-	72,5	59,5	-
54	-	-	-	-	-	48,7	-	56,5	47,5	-	54,5	44,9	65,0	53,5	43,6	64,5	53,0	-
58	-	-	-	-	-	-	-	-	42,3	-	49,1	39,7	57,0*	48,2	38,5	58,0	47,6	37,5
62	-	-	-	-	-	-	-	-	-	-	-	35,3	-	43,3	34,1	52,5	42,5	33,1
66	-	-	-	-	-	-	-	-	-	-	-	31,6	-	39,0	30,3	-	38,0	29,3
70	-	-	-	-	-	-	-	-	-	-	-	-	-	27,0	-	-	34,2	25,9
74	-	-	-	-	-	-	-	-	-	-	-	-	-	-	-	-	-	23,0
78	-	-	-	-	-	-	-	-	-	-	-	-	-	-	-	-	-	20,4

m	66 m			72 m			78 m			84 m			90 m			96 m		
	87°	75°	65°	87°	75°	65°	87°	75°	65°	87°	75°	65°	87°	75°	65°	87°	75°	65°
22	178,0	-	-	-	-	-	-	-	-	-	-	-	-	-	-	-	-	-
24	163,0	-	-	158,0	-	-	154,0	-	-	-	-	-	-	-	-	-	-	-
26	151,0	-	-	146,0	-	-	142,0	-	-	137,0	-	-	-	-	-	-	-	-
28	140,0	-	-	135,0	-	-	132,0	-	-	127,0	-	-	124,0	-	-	114,0	-	-
30	130,0	-	-	126,0	-	-	123,0	-	-	118,0	-	-	115,0	-	-	111,0	-	-
34	113,0	-	-	110,0	-	-	107,0	-	-	103,0	-	-	100,0	-	-	97,0	-	-
38	100,0	-	-	97,0	-	-	94,5	-	-	91,0	-	-	88,5	-	-	85,0	-	-
42	89,0	-	-	86,0	-	-	84,0	-	-	81,0	-	-	78,5	-	-	75,5	-	-
44	84,5	67,5	-	81,5	-	-	79,5	-	-	76,5	-	-	74,0	-	-	71,0	-	-
46	80,0	64,0	-	77,0	61,0	-	75,0	-	-	72,0	-	-	70,0	-	-	67,0	-	-
50	71,0	57,0	-	69,5	54,0	-	67,5	52,5	-	64,5	-	-	62,5	-	-	60,0	-	-
54	63,5	51,5	-	62,0	48,7	-	61,0	47,0	-	58,0	44,1	-	56,5	42,2	-	53,5	-	-
58	57,0	45,9	-	55,5	43,7	-	55,0	42,2	-	52,5	39,3	-	51,0	37,5	-	48,3	34,7	-
62	51,0	40,8	31,2	50,0	38,9	-	49,5	37,9	-	47,8	35,1	-	46,1	33,4	-	43,5	30,6	-
66	46,5	36,3	27,4	45,2	34,4	25,3	44,6	33,5	-	43,4	31,4	-	41,7	29,7	-	39,2	27,0	-
70	40,7*	32,4	24,0	40,9	30,6	22,0	40,3	29,7	20,9	39,2	28,0	-	37,9	26,4	-	35,4	23,8	-
74	-	29,0	21,1	37,2	27,1	19,0	36,6	26,3	18,0	35,2	24,7	16,2	34,3	23,5	14,9	32,0	20,9	-
78	-	-	18,5	-	24,1	16,4	33,1	23,2	15,4	31,7	21,6	13,6	30,7	20,5	12,4	28,8	18,3	10,1
82	-	-	16,1	-	21,4	14,1	28,3*	20,6	13,1	28,5	18,9	11,4	27,5	17,8	10,1	26,0	15,9	8,0
86	-	-	-	-	-	12,1	-	18,2	11,1	25,6	16,5	9,3	24,6	15,4	8,1	23,3	13,7	6,1
90	-	-	-	-	-	10,3	-	-	9,2	-	14,4	7,5	22,0	13,2	6,2	20,6	11,7	-
94	-	-	-	-	-	-	-	-	7,6	-	12,4	5,8	-	11,3	-	18,3	9,7	-
98	-	-	-	-	-	-	-	-	-	-	-	-	-	9,5	-	14,8*	7,9	-
102	-	-	-	-	-	-	-	-	-	-	-	-	-	-	-	-	6,3	-

Remarks · Bemerkungen · Remarques: \* Main boom angle 85° · Hauptauslegerwinkel 85° · Jarret de flèche principale 85°

Main boom angle 87°, 85°, 75° and 65°, capacities for intermediate boom positions are calculated by the crane control system IC-1

Hauptauslegerwinkel 87°, 85°, 75° und 65°, Traglasten für Zwischenstellungen des Hauptauslegers werden von der Kransteuerung IC-1 berechnet

Jarret de flèche principale 87°, 85°, 75° et 65°, le système de commande de la grue IC-1 calcule les charges pour les positions intermédiaires de la flèche



**SW LIFTING CAPACITIES · TRAGFÄHIGKEITEN · CAPACITÉS DE LEVAGE**

170-250 t 0-80 tZB 9,60 m 360° ISO

48 m

m	30 m			36 m			42 m			48 m			54 m			60 m		
	87°	75°	65°	87°	75°	65°	87°	75°	65°	87°	75°	65°	87°	75°	65°	87°	75°	65°
14	t	t	t	t	t	t	t	t	t	t	t	t	t	t	t	t	t	t
15	324,0	-	-	-	-	-	-	-	-	-	-	-	-	-	-	-	-	-
16	304,0	-	-	292,0	-	-	-	-	-	-	-	-	-	-	-	-	-	-
17	286,0	-	-	275,0	-	-	-	-	-	-	-	-	-	-	-	-	-	-
18	270,0	-	-	260,0	-	-	251,0	-	-	-	-	-	-	-	-	-	-	-
19	255,0	-	-	246,0	-	-	238,0	-	-	230,0	-	-	-	-	-	-	-	-
20	242,0	-	-	234,0	-	-	226,0	-	-	219,0	-	-	212,0	-	-	-	-	-
22	230,0	-	-	222,0	-	-	215,0	-	-	208,0	-	-	202,0	-	-	-	-	-
24	209,0	-	-	202,0	-	-	196,0	-	-	190,0	-	-	184,0	-	-	178,0	-	-
26	192,0	-	-	186,0	-	-	180,0	-	-	174,0	-	-	169,0	-	-	164,0	-	-
28	177,0	-	-	171,0	-	-	166,0	-	-	161,0	-	-	156,0	-	-	151,0	-	-
30	164,0	-	-	159,0	-	-	154,0	-	-	149,0	-	-	145,0	-	-	140,0	-	-
32	150,0	126,0	-	148,0	-	-	144,0	-	-	139,0	-	-	135,0	-	-	130,0	-	-
34	138,0	116,0	-	138,0	113,0	-	134,0	-	-	130,0	-	-	126,0	-	-	122,0	-	-
36	127,0	107,0	-	127,0	106,0	-	126,0	-	-	122,0	-	-	118,0	-	-	114,0	-	-
38	114,0*	99,0	-	117,0	98,0	-	117,0	96,0	-	115,0	-	-	111,0	-	-	107,0	-	-
40	-	91,5	-	109,0	90,5	-	108,0	89,5	-	107,0	86,5	-	105,0	-	-	101,0	-	-
42	-	85,5	-	101,0	84,5	-	101,0	83,5	-	99,5	81,5	-	99,0	78,5	-	95,5	-	-
44	-	79,5	67,0	-	78,5	-	94,5	78,0	-	93,0	75,5	-	92,5	74,0	-	90,5	70,5	-
46	-	74,5	62,5	-	73,5	-	88,5	73,0	-	87,0	70,5	-	86,5	70,0	-	85,5	66,5	-
48	-	-	58,0	-	69,0	56,5	83,5	68,5	-	82,0	66,0	-	81,5	65,5	-	81,0	62,5	-
50	-	-	51,0	-	61,5	49,8	-	60,5	48,5	73,0	58,5	-	72,0	57,5	-	72,0	56,0	-
54	-	-	-	-	-	44,0	-	54,0	42,7	-	52,0	40,0	64,5	51,0	-	64,5	50,5	-
58	-	-	-	-	-	39,1	-	-	37,8	-	46,6	35,1	56,0*	45,5	33,9	57,5	44,9	-
62	-	-	-	-	-	-	-	-	33,6	-	-	31,0	-	40,6	29,8	52,0	39,9	28,8
66	-	-	-	-	-	-	-	-	-	-	-	27,5	-	36,4	26,2	-	35,6	25,3
70	-	-	-	-	-	-	-	-	-	-	-	-	-	-	23,2	-	31,9	22,2
74	-	-	-	-	-	-	-	-	-	-	-	-	-	-	20,5	-	-	19,4
78	-	-	-	-	-	-	-	-	-	-	-	-	-	-	-	-	-	17,0

3

m	66 m			72 m			78 m			84 m			90 m			96 m		
	87°	75°	65°	87°	75°	65°	87°	75°	65°	87°	75°	65°	87°	75°	65°	87°	75°	65°
22	t	t	t	t	t	t	t	t	t	t	t	t	t	t	t	t	t	t
24	172,0	-	-	-	-	-	-	-	-	-	-	-	-	-	-	-	-	-
26	158,0	-	-	153,0	-	-	-	-	-	-	-	-	-	-	-	-	-	-
28	146,0	-	-	141,0	-	-	137,0	-	-	133,0	-	-	-	-	-	-	-	-
30	135,0	-	-	131,0	-	-	127,0	-	-	123,0	-	-	120,0	-	-	-	-	-
34	126,0	-	-	122,0	-	-	119,0	-	-	114,0	-	-	111,0	-	-	107,0	-	-
38	110,0	-	-	106,0	-	-	104,0	-	-	100,0	-	-	97,5	-	-	93,5	-	-
42	97,0	-	-	94,0	-	-	91,5	-	-	88,0	-	-	85,5	-	-	82,5	-	-
46	86,5	-	-	83,5	-	-	81,5	-	-	78,0	-	-	76,0	-	-	73,0	-	-
48	77,5	59,0	-	74,5	-	-	73,0	-	-	69,5	-	-	67,5	-	-	64,5	-	-
50	73,5	55,5	-	71,0	52,5	-	69,0	-	-	66,0	-	-	64,0	-	-	61,0	-	-
54	70,0	52,5	-	67,0	49,8	-	65,5	48,0	-	62,5	-	-	60,5	-	-	57,5	-	-
58	63,0	47,3	-	60,5	44,5	-	59,0	42,8	-	56,5	39,8	-	54,5	-	-	51,5	-	-
62	56,5	42,5	-	55,0	39,8	-	53,5	38,2	-	51,0	35,3	-	49,3	33,5	-	46,6	30,7	-
66	51,0	38,2	-	49,8	35,7	-	48,8	34,2	-	46,2	31,4	-	44,5	29,6	-	41,9	26,9	-
70	46,2	33,9	23,4	44,9	32,0	21,2	44,3	30,6	-	41,9	27,8	-	40,3	26,2	-	37,7	23,5	-
74	40,2*	30,2	20,2	40,6	28,2	18,1	40,0	27,3	17,0	38,1	24,7	-	36,5	23,1	-	34,0	20,5	-
78	-	26,8	17,5	36,9	25,0	15,4	36,2	24,0	14,3	34,6	21,9	12,1	33,1	20,3	-	30,6	17,7	-
82	-	23,9	15,1	-	22,0	13,0	32,7	21,1	11,9	31,3	19,3	9,9	30,0	17,8	-	27,6	15,2	-
86	-	-	12,9	-	19,4	10,8	27,7*	18,5	9,8	28,1	16,9	8,0	27,1	15,5	-	24,8	13,0	-
90	-	-	11,0	-	-	8,9	-	16,2	7,9	25,3	14,6	6,1	24,3	13,4	-	22,3	10,9	-
94	-	-	-	-	-	7,2	-	14,2	6,2	-	12,5	-	21,7	11,4	-	20,0	9,0	-
98	-	-	-	-	-	-	-	-	-	-	10,6	-	17,7*	9,5	-	17,9	7,3	-
102	-	-	-	-	-	-	-	-	-	-	-	-	-	7,8	-	15,9	5,7	-

**Remarks · Bemerkungen · Remarques:** \* Main boom angle 85° · Hauptauslegerwinkel 85° · Jarret de flèche principale 85°

Main boom angle 87°, 85°, 75° and 65°, capacities for intermediate boom positions are calculated by the crane control system IC-1

Hauptauslegerwinkel 87°, 85°, 75° und 65°, Traglasten für Zwischenstellungen des Hauptauslegers werden von der Kransteuerung IC-1 berechnet

Jarret de flèche principale 87°, 85°, 75° et 65°, le système de commande de la grue IC-1 calcule les charges pour les positions intermédiaires de la flèche

**SW LIFTING CAPACITIES · TRAGFÄHIGKEITEN · CAPACITÉS DE LEVAGE**
 170-250 t 0-80 tZB  9,60 m 360° ISO
 54 m

m	30 m			36 m			42 m			48 m			54 m			60 m		
	87°	75°	65°	87°	75°	65°	87°	75°	65°	87°	75°	65°	87°	75°	65°	87°	75°	65°
	t	t	t	t	t	t	t	t	t	t	t	t	t	t	t	t	t	t
14	310,0	-	-	-	-	-	-	-	-	-	-	-	-	-	-	-	-	-
16	274,0	-	-	264,0	-	-	-	-	-	-	-	-	-	-	-	-	-	-
17	259,0	-	-	250,0	-	-	242,0	-	-	-	-	-	-	-	-	-	-	-
18	246,0	-	-	237,0	-	-	229,0	-	-	221,0	-	-	-	-	-	-	-	-
20	222,0	-	-	214,0	-	-	208,0	-	-	201,0	-	-	195,0	-	-	-	-	-
22	202,0	-	-	196,0	-	-	190,0	-	-	183,0	-	-	178,0	-	-	172,0	-	-
24	186,0	-	-	180,0	-	-	174,0	-	-	169,0	-	-	164,0	-	-	158,0	-	-
26	172,0	-	-	166,0	-	-	161,0	-	-	156,0	-	-	151,0	-	-	146,0	-	-
28	159,0	-	-	154,0	-	-	150,0	-	-	145,0	-	-	140,0	-	-	136,0	-	-
30	149,0	-	-	143,0	-	-	139,0	-	-	135,0	-	-	131,0	-	-	126,0	-	-
32	137,0	110,0	-	134,0	-	-	130,0	-	-	126,0	-	-	122,0	-	-	118,0	-	-
34	126,0	103,0	-	126,0	99,0	-	122,0	-	-	118,0	-	-	115,0	-	-	111,0	-	-
36	113,0*	95,0	-	116,0	93,0	-	115,0	89,5	-	111,0	-	-	108,0	-	-	104,0	-	-
38	-	88,0	-	108,0	87,0	-	108,0	84,0	-	105,0	-	-	102,0	-	-	98,5	-	-
40	-	82,0	-	101,0	81,0	-	100,0	79,5	-	99,0	75,5	-	96,5	-	-	92,5	-	-
42	-	76,5	-	91,0*	75,5	-	94,0	74,5	-	92,5	71,5	-	91,0	68,5	-	87,5	-	-
44	-	71,5	-	-	70,5	-	88,0	69,5	-	86,5	67,5	-	86,0	64,5	-	83,0	61,0	-
46	-	67,0	52,5	-	66,0	-	83,0	65,0	-	81,5	63,0	-	81,0	61,0	-	79,0	57,5	-
48	-	-	49,2	-	62,0	47,7	75,0*	61,5	-	76,5	59,0	-	76,0	58,0	-	75,0	54,5	-
50	-	-	46,0	-	58,5	44,5	-	57,5	-	72,0	55,5	-	71,5	54,5	-	71,5	51,5	-
54	-	-	40,5	-	-	39,1	-	51,5	37,7	62,0*	49,2	-	64,0	48,1	-	64,0	46,5	-
58	-	-	-	-	-	34,5	-	-	33,1	-	43,6	30,4	55,0*	42,6	29,1	57,5	41,9	-
62	-	-	-	-	-	-	-	-	29,3	-	39,0	26,6	-	37,9	25,3	51,5	37,2	24,4
66	-	-	-	-	-	-	-	-	26,0	-	-	23,3	-	33,8	22,0	-	33,1	21,1
70	-	-	-	-	-	-	-	-	-	-	-	20,5	-	-	19,2	-	29,5	18,3
74	-	-	-	-	-	-	-	-	-	-	-	-	-	-	16,7	-	26,4	15,7
78	-	-	-	-	-	-	-	-	-	-	-	-	-	-	14,7	-	-	13,5
82	-	-	-	-	-	-	-	-	-	-	-	-	-	-	-	-	-	11,6

m	66 m			72 m			78 m			84 m			90 m			96 m		
	87°	75°	65°	87°	75°	65°	87°	75°	65°	87°	75°	65°	87°	75°	65°	87°	75°	65°
	t	t	t	t	t	t	t	t	t	t	t	t	t	t	t	t	t	t
22	166,0	-	-	-	-	-	-	-	-	-	-	-	-	-	-	-	-	-
24	152,0	-	-	147,0	-	-	-	-	-	-	-	-	-	-	-	-	-	-
26	141,0	-	-	136,0	-	-	133,0	-	-	128,0	-	-	-	-	-	-	-	-
28	131,0	-	-	126,0	-	-	123,0	-	-	119,0	-	-	116,0	-	-	-	-	-
30	122,0	-	-	118,0	-	-	115,0	-	-	111,0	-	-	107,0	-	-	103,0	-	-
34	106,0	-	-	103,0	-	-	100,0	-	-	96,5	-	-	94,0	-	-	90,5	-	-
38	94,0	-	-	91,0	-	-	88,5	-	-	85,0	-	-	83,0	-	-	79,5	-	-
42	84,0	-	-	81,0	-	-	79,0	-	-	75,5	-	-	73,5	-	-	70,0	-	-
46	75,5	-	-	72,5	-	-	70,5	-	-	67,5	-	-	65,5	-	-	62,5	-	-
48	71,5	51,0	-	68,5	-	-	67,0	-	-	64,0	-	-	62,0	-	-	59,0	-	-
50	68,0	48,2	-	65,0	45,2	-	63,5	-	-	60,5	-	-	58,5	-	-	55,5	-	-
54	61,5	43,1	-	59,0	40,2	-	57,0	38,5	-	54,5	35,5	-	52,5	-	-	50,0	-	-
58	56,0	38,5	-	53,5	35,8	-	52,0	34,2	-	49,2	31,3	-	47,5	29,5	-	44,8	-	-
62	50,5	34,6	-	48,6	31,9	-	47,2	30,4	-	44,5	27,6	-	42,9	25,9	-	40,3	23,1	-
66	45,9	31,1	19,1	44,4	28,5	-	43,0	27,1	-	40,4	24,3	-	38,7	22,7	-	36,2	19,9	-
70	39,5*	27,8	16,4	40,3	25,4	13,9	39,2	24,1	-	36,6	21,4	-	35,1	19,8	-	32,6	17,1	-
74	-	24,6	13,8	36,5	22,7	11,6	35,8	21,4	10,3	33,3	18,7	-	31,7	17,2	-	29,3	14,5	-
78	-	21,8	11,6	-	19,9	9,4	32,3	18,9	8,3	30,3	16,3	-	28,7	14,8	-	26,3	12,2	-
82	-	-	9,6	-	17,4	7,5	27,0*	16,4	6,3	27,5	14,1	-	26,0	12,6	-	23,6	10,1	-
86	-	-	7,8	-	15,2	5,7	-	14,2	-	24,9	12,1	-	23,5	10,7	-	21,2	8,2	-
90	-	-	-	-	-	-	-	12,3	-	-	10,3	-	21,3	8,8	-	18,9	6,4	-
94	-	-	-	-	-	-	-	-	-	-	8,6	-	17,1*	7,2	-	16,8	-	-
98	-	-	-	-	-	-	-	-	-	-	7,0	-	-	5,6	-	15,0	-	-

**Remarks · Bemerkungen · Remarques:**

Main boom angle 87°, 85°, 75° and 65°, capacities for intermediate boom positions are calculated by the crane control system IC-1  
 Hauptauslegerwinkel 87°, 85°, 75° und 65°, Traglasten für Zwischenstellungen des Hauptauslegers werden von der Kransteuerung IC-1 berechnet  
 Jarret de flèche principale 87°, 85°, 75° et 65°, le système de commande de la grue IC-1 calcule les charges pour les positions intermédiaires de la flèche

\* Main boom angle 85° · Hauptauslegerwinkel 85° · Jarret de flèche principale 85°

**SW LIFTING CAPACITIES · TRAGFÄHIGKEITEN · CAPACITÉS DE LEVAGE**

 170-250 t 0-80 tZB 9,60 m 360° ISO

60 m

m	30 m			36 m			42 m			48 m			54 m			60 m		
	87°	75°	65°	87°	75°	65°	87°	75°	65°	87°	75°	65°	87°	75°	65°	87°	75°	65°
14	t	t	t	t	t	t	t	t	t	t	t	t	t	t	t	t	t	t
16	297,0	-	-	-	-	-	-	-	-	-	-	-	-	-	-	-	-	-
17	263,0	-	-	254,0	-	-	-	-	-	-	-	-	-	-	-	-	-	-
18	249,0	-	-	240,0	-	-	232,0	-	-	-	-	-	-	-	-	-	-	-
19	236,0	-	-	228,0	-	-	221,0	-	-	-	-	-	-	-	-	-	-	-
20	224,0	-	-	217,0	-	-	210,0	-	-	203,0	-	-	-	-	-	-	-	-
22	214,0	-	-	207,0	-	-	200,0	-	-	193,0	-	-	187,0	-	-	-	-	-
24	195,0	-	-	189,0	-	-	183,0	-	-	177,0	-	-	171,0	-	-	166,0	-	-
26	180,0	-	-	173,0	-	-	168,0	-	-	163,0	-	-	158,0	-	-	153,0	-	-
28	166,0	-	-	160,0	-	-	156,0	-	-	150,0	-	-	146,0	-	-	141,0	-	-
30	154,0	-	-	149,0	-	-	145,0	-	-	140,0	-	-	136,0	-	-	131,0	-	-
34	144,0	-	-	139,0	-	-	135,0	-	-	130,0	-	-	126,0	-	-	122,0	-	-
36	125,0	96,0	-	122,0	-	-	119,0	-	-	114,0	-	-	111,0	-	-	107,0	-	-
38	111,0*	90,0	-	115,0	86,0	-	112,0	-	-	108,0	-	-	104,0	-	-	101,0	-	-
42	-	84,0	-	107,0	81,0	-	105,0	77,5	-	102,0	-	-	98,5	-	-	95,0	-	-
44	-	72,5	-	90,0*	71,5	-	93,5	69,0	-	91,5	65,5	-	88,5	-	-	85,0	-	-
46	-	68,0	-	-	67,0	-	87,5	65,5	-	86,0	62,0	-	84,0	59,0	-	80,5	-	-
48	-	63,5	-	-	62,5	-	82,0	62,0	-	80,5	58,5	-	79,5	55,5	-	76,5	52,5	-
50	-	-	43,0	-	59,0	-	74,0*	58,0	-	76,0	55,5	-	75,5	52,5	-	72,5	49,5	-
54	-	-	40,1	-	55,5	-	-	54,5	-	71,5	52,0	-	71,0	50,0	-	69,0	46,8	-
58	-	-	35,0	-	-	33,6	-	48,1	32,2	61,0*	45,7	-	63,5	44,6	-	63,0	41,9	-
62	-	-	-	-	-	29,3	-	42,8	28,0	-	40,4	25,1	57,0	39,3	-	57,0	37,6	-
66	-	-	-	-	-	25,8	-	-	24,4	-	35,9	21,6	-	34,8	20,4	51,5	33,9	-
70	-	-	-	-	-	-	-	-	21,4	-	-	18,6	-	30,9	17,4	44,2*	30,3	16,5
74	-	-	-	-	-	-	-	-	-	-	-	16,1	-	27,6	14,8	-	26,9	13,9
78	-	-	-	-	-	-	-	-	-	-	-	13,9	-	-	12,5	-	23,8	11,6
82	-	-	-	-	-	-	-	-	-	-	-	-	-	-	10,6	-	-	9,6
86	-	-	-	-	-	-	-	-	-	-	-	-	-	-	-	-	-	7,8
	-	-	-	-	-	-	-	-	-	-	-	-	-	-	-	-	-	6,3

m	66 m		
	87°	75°	65°
24	t	t	t
26	147,0	-	-
28	136,0	-	-
30	126,0	-	-
34	117,0	-	-
38	103,0	-	-
42	91,0	-	-
46	81,0	-	-
48	73,0	-	-
50	69,0	45,8	-
54	65,5	43,2	-
58	59,5	38,4	-
62	54,0	34,3	-
66	49,5	30,6	-
70	45,3	27,3	-
74	38,5*	24,4	11,5
78	-	21,7	9,4
82	-	19,3	7,6
86	-	17,0	5,9

**Remarks · Bemerkungen · Remarques:**

Main boom angle 87°, 85°, 75° and 65°, capacities for intermediate boom positions are calculated by the crane control system IC-1  
 Hauptauslegerwinkel 87°, 85°, 75° und 65°, Traglasten für Zwischenstellungen des Hauptauslegers werden von der Kransteuerung IC-1 berechnet  
 Jarret de flèche principale 87°, 85°, 75° et 65°, le système de commande de la grue IC-1 calcule les charges pour les positions intermédiaires de la flèche

\* Main boom angle 85° · Hauptauslegerwinkel 85° · Jarret de flèche principale 85°

**SWSL** WORKING RANGES · ARBEITSBEREICHE · PORTÉES

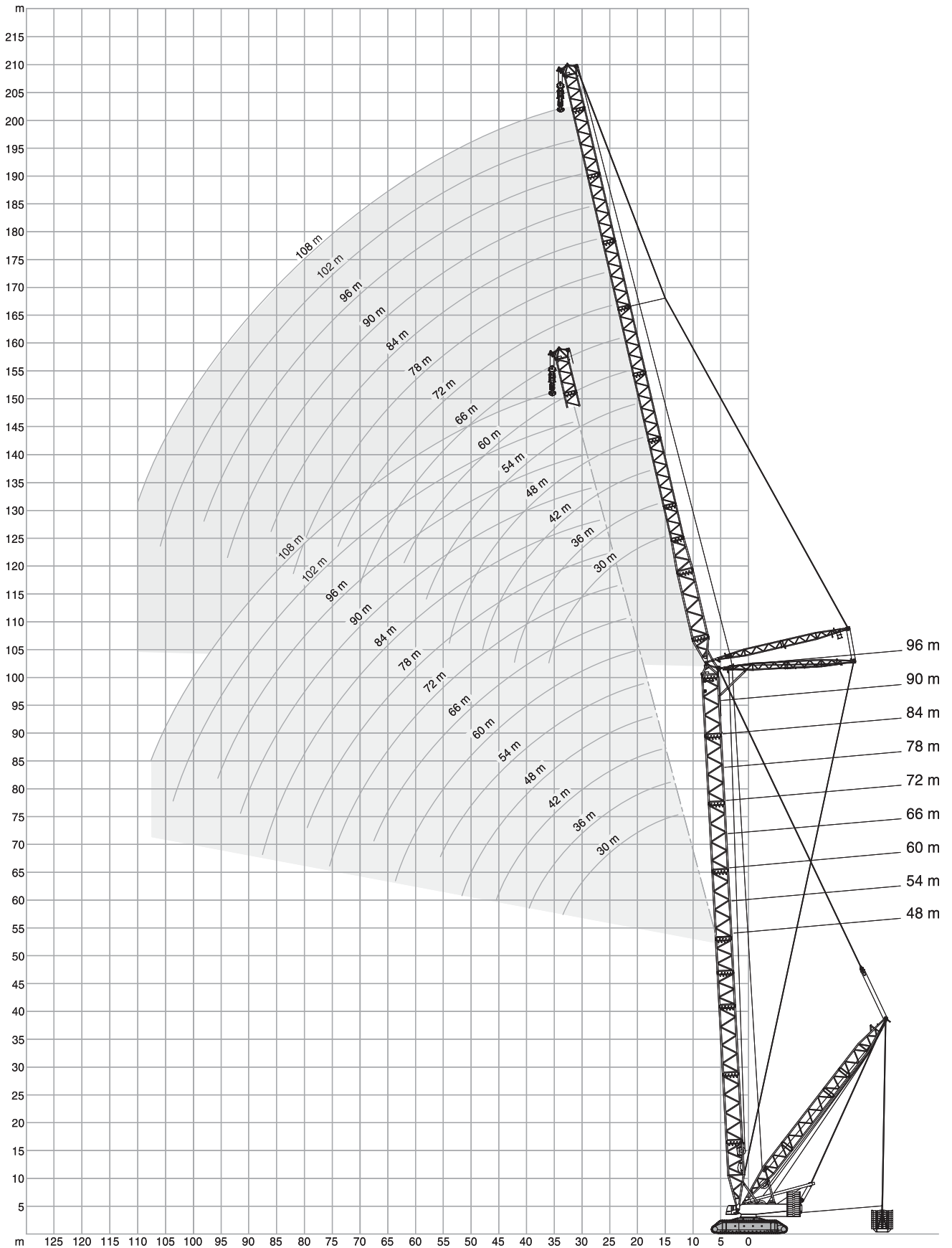

**SWSL / SFSL15° LIFTING CAPACITIES · TRAGFÄHIGKEITEN · CAPACITÉS DE LEVAGE**

48 m + 36 m

m	SWSL							SFSL
	0 t		80 t-450 t					
	85°	85°	75°	65°	55°	45°	t	
15	-	484,0*	-	-	-	-	-	
16	-	484,0*	-	-	-	-	-	
18	280,0	501,0	-	-	-	-	-	
19	266,0	501,0	-	-	-	-	467,0	
20	253,0	496,0	-	-	-	-	467,0	
22	231,0	484,0	-	-	-	-	467,0	
24	210,0	471,0	-	-	-	-	467,0	
26	190,0	436,0	-	-	-	-	467,0	
28	172,5	391,0	-	-	-	-	464,0	
30	158,0	354,0	-	-	-	-	451,0	
32	145,5	323,0	425,0	-	-	-	421,5	
34	134,5	297,0	399,0	-	-	-	392,0	
38	116,0	255,0	354,0	-	-	-	344,0	
40	108,5	238,0	329,0	-	-	-	325,0	
42	-	-	302,0	-	-	-	306,0	
46	-	-	259,0	276,0	-	-	274,0	
50	-	-	226,0	251,0	-	-	247,0	
54	-	-	-	230,0	-	-	217,0	
58	-	-	-	212,0	188,0	-	191,0	
62	-	-	-	-	173,5	-	168,0	
66	-	-	-	-	-	-	153,0	
70	-	-	-	-	-	-	133,0	
74	-	-	-	-	-	-	115,0	
78	-	-	-	-	-	-	97,0	
82	-	-	-	-	-	-	-	

48 m + 60 m

m	SWSL							SFSL
	0 t		80 t-450 t					
	85°	85°	75°	65°	55°	45°	t	
22	-	282,0*	-	-	-	-	-	
24	188,0	287,0	-	-	-	-	-	
26	173,5	287,0	-	-	-	-	-	
28	161,5	285,0	-	-	-	-	278,0	
30	150,5	284,0	-	-	-	-	278,0	
34	132,0	277,0	-	-	-	-	278,0	
38	114,5	268,0	-	-	-	-	278,0	
42	99,6	237,0	278,0	-	-	-	278,0	
46	87,4	209,0	276,0	-	-	-	271,0	
50	77,2	186,0	241,0	-	-	-	252,0	
54	68,7	166,5	212,0	-	-	-	229,0	
58	61,4	150,0	188,5	-	-	-	209,0	
62	55,0	136,0	169,0	193,0	-	-	192,0	
66	-	-	152,5	179,0	-	-	174,0	
70	-	-	138,0	166,0	-	-	156,0	
74	-	-	-	153,0	-	-	140,0	
78	-	-	-	138,5	126,0	-	125,0	
82	-	-	-	-	118,0	-	116,0	
86	-	-	-	-	111,5	-	104,0	
90	-	-	-	-	-	92,6	92,0	
94	-	-	-	-	-	87,1	80,5	
98	-	-	-	-	-	-	69,0	
102	-	-	-	-	-	-	57,5	

48 m + 48 m

m	SWSL							SFSL
	85°	85°	75°	65°	55°	45°	t	
18	-	368,0*	-	-	-	-	-	
20	-	366,0*	-	-	-	-	-	
22	217,0	378,0	-	-	-	-	-	
24	199,5	377,0	-	-	-	-	359,0	
26	184,5	374,0	-	-	-	-	359,0	
28	170,0	367,0	-	-	-	-	359,0	
30	155,5	359,0	-	-	-	-	359,0	
34	132,0	315,0	-	-	-	-	359,0	
38	113,5	269,0	351,0	-	-	-	347,0	
42	99,2	234,0	313,0	-	-	-	308,0	
46	87,3	206,0	274,0	-	-	-	276,0	
50	77,5	183,0	238,0	-	-	-	249,0	
54	-	-	209,0	227,0	-	-	226,0	
58	-	-	186,0	209,0	-	-	204,0	
62	-	-	-	193,0	-	-	181,0	
66	-	-	-	179,0	157,0	-	161,0	
70	-	-	-	-	145,5	-	143,0	
74	-	-	-	-	136,0	-	132,0	
78	-	-	-	-	-	114,5	116,0	
82	-	-	-	-	-	107,0	102,0	
86	-	-	-	-	-	-	88,0	
90	-	-	-	-	-	-	74,0	
94	-	-	-	-	-	-	-	

48 m + 72 m

m	SWSL							SFSL
	85°	85°	75°	65°	55°	45°	t	
24	-	216,0*	-	-	-	-	-	
26	-	214,0*	-	-	-	-	-	
28	151,0	216,0	-	-	-	-	-	
30	141,0	216,0	-	-	-	-	210,0	
34	123,5	213,0	-	-	-	-	210,0	
38	107,5	208,0	-	-	-	-	210,0	
42	93,4	204,0	-	-	-	-	210,0	
46	81,7	199,0	-	-	-	-	209,0	
48	76,6	192,5	205,0	-	-	-	208,0	
50	72,0	181,5	205,0	-	-	-	207,0	
54	63,8	162,5	204,0	-	-	-	201,0	
58	56,7	147,0	184,0	-	-	-	195,0	
62	50,6	133,0	165,0	-	-	-	183,0	
66	45,3	121,5	149,0	172,0	-	-	172,0	
70	40,6	111,0	135,0	160,0	-	-	161,0	
74	36,4	101,5	123,0	149,0	-	-	145,0	
78	-	-	112,5	135,5	-	-	130,0	
82	-	-	103,0	123,5	-	-	117,0	
86	-	-	-	113,0	106,5	-	106,0	
90	-	-	-	103,5	100,0	-	99,0	
94	-	-	-	-	94,9	-	89,0	
98	-	-	-	-	89,9	76,6	79,0	
102	-	-	-	-	-	72,1	69,5	
106	-	-	-	-	-	67,9	60,5	
110	-	-	-	-	-	-	51,0	
114	-	-	-	-	-	-	42,0	
118	-	-	-	-	-	-	-	

**Remarks · Bemerkungen · Remarques**

Main boom angle 87°, 85°, 75°, 65°, 55° and 45°; capacities for intermediate boom positions are calculated by the crane control system IC-1  
 Hauptauslegerwinkel 87°, 85°, 75°, 65°, 55° und 45°; Traglasten für Zwischenstellungen des Hauptauslegers werden von der Kransteuerung IC-1 berechnet  
 Jarret de flèche principale 87°, 85°, 75°, 65°, 55° et 45°; le système de commande de la grue IC-1 calcule les charges pour les positions intermédiaires de la flèche

\* Main boom angle 87° · Hauptauslegerwinkel 87° · Jarret de flèche principale 87°

# SWSL / SFSL15° LIFTING CAPACITIES · TRAGFÄHIGKEITEN · CAPACITÉS DE LEVAGE

170-250 t 0-80 t ZB 15-24 m 9,60 m 360° ISO

48 m + 84 m

m	SWSL							SFSL
	0 t		80 t-450 t					
	85°	85°	75°	65°	55°	45°	t	
26	-	164,5*	-	-	-	-	-	
28	-	164,0*	-	-	-	-	-	
30	-	162,5*	-	-	-	-	-	
32	124,5	164,0	-	-	-	-	-	
34	116,5	163,0	-	-	-	-	160,0	
38	103,0	161,0	-	-	-	-	159,0	
42	91,2	158,5	-	-	-	-	159,0	
46	79,5	156,0	-	-	-	-	159,0	
50	69,8	153,0	-	-	-	-	157,0	
54	61,6	150,0	152,5	-	-	-	156,0	
58	54,5	146,0	152,5	-	-	-	153,0	
62	48,5	132,5	152,5	-	-	-	151,0	
66	43,1	120,5	148,0	-	-	-	148,0	
70	38,4	110,0	134,0	-	-	-	146,0	
74	34,2	101,0	122,0	136,0	-	-	140,0	
78	30,5	93,2	111,5	134,5	-	-	132,0	
82	27,1	85,9	102,5	122,5	-	-	124,0	
86	24,1	79,2	94,4	112,0	-	-	112,0	
90	-	-	87,1	103,0	-	-	101,0	
94	-	-	80,3	94,8	92,6	-	93,0	
98	-	-	-	87,4	87,6	-	86,5	
102	-	-	-	80,8	83,0	-	77,5	
106	-	-	-	-	78,7	-	69,0	
110	-	-	-	-	74,6	60,9	61,0	
114	-	-	-	-	-	57,4	53,5	
118	-	-	-	-	-	54,1	46,1	
122	-	-	-	-	-	-	38,4	
126	-	-	-	-	-	-	30,5	
130	-	-	-	-	-	-	-	

48 m + 96 m

m	t	t	t	t	t	t	t
30	-	123,5*	-	-	-	-	-
34	109,5	122,5	-	-	-	-	-
38	97,1	121,0	-	-	-	-	119,0
42	86,4	119,0	-	-	-	-	118,0
46	77,2	117,0	-	-	-	-	117,0
50	67,5	115,0	-	-	-	-	117,0
54	59,2	112,5	-	-	-	-	115,0
58	52,2	110,0	110,5	-	-	-	113,0
62	46,0	108,0	110,0	-	-	-	112,0
66	40,7	105,5	109,5	-	-	-	109,0
70	36,0	103,0	108,5	-	-	-	107,0
74	31,8	100,0	107,5	-	-	-	105,0
78	28,1	91,9	106,0	-	-	-	103,0
82	24,7	84,7	101,0	96,5	-	-	101,0
86	21,7	78,1	93,1	96,5	-	-	99,5
90	18,9	72,2	85,7	96,5	-	-	97,5
94	16,3	66,8	79,1	93,3	-	-	95,0
98	14,0	61,7	73,2	86,0	-	-	87,5
102	-	-	67,7	79,5	80,6	-	81,0
106	-	-	62,6	73,5	75,9	-	75,0
110	-	-	-	68,0	71,5	-	67,5
114	-	-	-	63,0	67,5	-	60,0
118	-	-	-	-	63,8	51,2	53,0
122	-	-	-	-	60,3	48,5	46,7
126	-	-	-	-	-	46,0	40,2
130	-	-	-	-	-	43,6	33,8
134	-	-	-	-	-	-	27,3

48 m + 108 m

m	SWSL							SFSL
	0 t		80 t-450 t					
	85°	85°	75°	65°	55°	45°	t	
32	-	94,2*	-	-	-	-	-	
34	-	93,8*	-	-	-	-	-	
38	88,3	93,0	-	-	-	-	-	
42	80,8	91,6	-	-	-	-	90,5	
46	72,0	90,2	-	-	-	-	89,5	
50	64,5	88,8	-	-	-	-	89,0	
54	57,1	87,3	-	-	-	-	88,0	
58	50,0	85,8	-	-	-	-	86,5	
62	43,9	84,2	-	-	-	-	85,5	
66	38,5	82,7	82,2	-	-	-	84,0	
70	33,8	81,2	81,7	-	-	-	82,5	
74	29,6	79,7	81,2	-	-	-	81,0	
78	25,8	78,0	80,6	-	-	-	79,0	
82	22,4	75,7	80,0	-	-	-	77,5	
86	19,4	72,8	79,3	-	-	-	76,0	
90	16,6	69,8	78,7	70,6	-	-	74,5	
94	14,0	65,6	77,8	70,6	-	-	73,0	
98	11,7	60,6	71,8	70,6	-	-	71,5	
102	9,5	56,1	66,4	70,6	-	-	69,5	
106	7,6	51,9	61,4	70,6	-	-	67,5	
110	5,7	47,9	56,9	66,7	61,6	-	65,5	
114	-	-	52,6	61,7	61,6	-	63,0	
118	-	-	48,6	57,1	61,0	-	58,0	
122	-	-	-	52,9	57,5	-	52,0	
126	-	-	-	48,9	54,2	-	46,0	
130	-	-	-	-	51,2	41,0	40,2	
134	-	-	-	-	48,3	38,7	34,5	
138	-	-	-	-	-	36,6	28,9	
142	-	-	-	-	-	-	23,4	
146	-	-	-	-	-	-	17,7	
150	-	-	-	-	-	-	-	

## Remarks · Bemerkungen · Remarques

Main boom angle 87°, 85°, 75°, 65°, 55° and 45°; capacities for intermediate boom positions are calculated by the crane control system IC-1

Hauptauslegerwinkel 87°, 85°, 75°, 65°, 55° und 45°; Traglasten für Zwischenstellungen des Hauptauslegers werden von der Kransteuerung IC-1 berechnet

Jarret de flèche principale 87°, 85°, 75°, 65°, 55° et 45°; le système de commande de la grue IC-1 calcule les charges pour les positions intermédiaires de la flèche

\* Main boom angle 87°  
Hauptauslegerwinkel 87°  
Jarret de flèche principale 87°

**SWSL / SFSL15° LIFTING CAPACITIES · TRAGFÄHIGKEITEN · CAPACITÉS DE LEVAGE**

170-250 t 0-80 t ZB 15-24 m 9,60 m 360° ISO

54 m + 36 m

m	SWSL						SFSL
	0 t		80 t-450 t				
	85°	85°	75°	65°	55°	45°	t
16	-	450,0*	-	-	-	-	-
18	-	439,0*	-	-	-	-	-
19	256,0	463,0	-	-	-	-	434,0
20	244,0	458,0	-	-	-	-	434,0
22	222,0	448,0	-	-	-	-	434,0
24	205,0	437,0	-	-	-	-	434,0
26	187,5	425,0	-	-	-	-	434,0
28	170,5	401,0	-	-	-	-	430,0
30	156,0	363,0	-	-	-	-	426,0
34	132,5	303,0	394,0	-	-	-	389,0
38	114,5	260,0	350,0	-	-	-	341,0
42	99,9	226,0	312,0	-	-	-	303,0
46	-	-	274,0	-	-	-	271,0
48	-	-	254,0	259,0	-	-	257,5
50	-	-	237,0	247,0	-	-	244,0
54	-	-	-	226,0	-	-	221,0
58	-	-	-	208,0	-	-	202,0
62	-	-	-	-	177,5	-	178,0
66	-	-	-	-	164,5	-	157,0
70	-	-	-	-	-	-	138,0
74	-	-	-	-	-	-	127,0
78	-	-	-	-	-	-	110,0
82	-	-	-	-	-	-	93,5

54 m + 48 m

m	t	t	t	t	t	t	t
18	-	345,0*	-	-	-	-	-
20	-	343,0*	-	-	-	-	-
22	209,0	352,0	-	-	-	-	-
24	192,5	351,0	-	-	-	-	336,0
26	178,0	348,0	-	-	-	-	336,0
28	165,5	342,0	-	-	-	-	336,0
30	153,5	335,0	-	-	-	-	336,0
34	130,0	321,0	-	-	-	-	333,0
38	112,0	278,0	-	-	-	-	330,0
40	104,0	258,0	328,0	-	-	-	317,5
42	97,5	241,0	310,0	-	-	-	305,0
46	85,8	212,0	279,0	-	-	-	273,0
50	76,0	188,0	254,0	-	-	-	246,0
54	67,8	166,5	222,0	-	-	-	223,0
58	-	-	197,0	205,0	-	-	203,0
62	-	-	175,5	190,0	-	-	186,0
66	-	-	-	176,5	-	-	170,0
70	-	-	-	165,0	148,5	-	151,0
74	-	-	-	-	138,5	-	135,0
78	-	-	-	-	130,0	-	119,0
82	-	-	-	-	-	108,5	110,0
86	-	-	-	-	-	102,0	97,5
90	-	-	-	-	-	-	84,5
94	-	-	-	-	-	-	75,0
98	-	-	-	-	-	-	-

**Remarks · Bemerkungen · Remarques**

Main boom angle 87°, 85°, 75°, 65°, 55° and 45°; capacities for intermediate boom positions are calculated by the crane control system IC-1

Hauptauslegerwinkel 87°, 85°, 75°, 65°, 55° und 45°; Traglasten für Zwischenstellungen des Hauptauslegers werden von der Kransteuerung IC-1 berechnet

Jarret de flèche principale 87°, 85°, 75°, 65°, 55° et 45°; le système de commande de la grue IC-1 calcule les charges pour les positions intermédiaires de la flèche

\* Main boom angle 87° · Hauptauslegerwinkel 87° · Jarret de flèche principale 87°

54 m + 60 m

m	SWSL						SFSL
	0 t		80 t-450 t				
	85°	85°	75°	65°	55°	45°	t
22	-	265,0*	-	-	-	-	-
24	-	264,0*	-	-	-	-	-
26	167,5	270,0	-	-	-	-	-
28	156,0	269,0	-	-	-	-	262,0
30	145,5	268,0	-	-	-	-	262,0
34	128,0	262,0	-	-	-	-	262,0
38	113,0	254,0	-	-	-	-	262,0
42	98,1	245,0	-	-	-	-	260,0
44	91,8	229,0	265,0	-	-	-	257,5
46	86,0	215,0	263,0	-	-	-	257,0
50	75,9	191,5	256,0	-	-	-	248,0
54	67,5	171,0	226,0	-	-	-	227,0
58	60,2	154,5	200,0	-	-	-	207,0
62	54,0	139,5	178,5	190,5	-	-	189,0
66	-	-	160,5	177,0	-	-	174,0
70	-	-	145,5	164,5	-	-	160,0
74	-	-	132,0	154,0	-	-	147,0
78	-	-	-	144,5	128,5	-	132,0
82	-	-	-	136,0	120,5	-	119,0
86	-	-	-	-	113,0	-	106,0
90	-	-	-	-	106,0	-	97,0
94	-	-	-	-	-	88,4	88,0
98	-	-	-	-	-	83,3	77,0
102	-	-	-	-	-	-	66,5
106	-	-	-	-	-	-	61,0

54 m + 72 m

m	t	t	t	t	t	t	t
24	-	204,0*	-	-	-	-	-
26	-	203,0*	-	-	-	-	-
28	145,5	206,0	-	-	-	-	-
30	136,0	205,0	-	-	-	-	-
34	119,5	202,0	-	-	-	-	200,0
38	105,5	199,0	-	-	-	-	200,0
42	91,9	195,0	-	-	-	-	200,0
46	80,3	190,5	-	-	-	-	200,0
50	70,7	186,0	196,5	-	-	-	200,0
54	62,6	167,5	196,0	-	-	-	194,0
58	55,6	151,0	194,5	-	-	-	189,0
62	49,6	137,0	174,5	-	-	-	184,0
66	44,3	124,5	157,0	-	-	-	174,0
70	39,7	114,0	142,0	158,5	-	-	160,0
74	35,5	104,5	129,5	148,5	-	-	148,0
78	-	-	118,0	139,0	-	-	137,0
82	-	-	108,0	131,0	-	-	124,0
86	-	-	99,4	121,5	107,0	-	112,0
90	-	-	-	111,0	100,5	-	100,0
94	-	-	-	102,0	94,8	-	90,0
98	-	-	-	-	89,4	-	83,5
102	-	-	-	-	84,3	73,1	75,5
106	-	-	-	-	-	68,9	66,5
110	-	-	-	-	-	65,0	58,0
114	-	-	-	-	-	-	51,5
118	-	-	-	-	-	-	45,0
122	-	-	-	-	-	-	-

# SWSL / SFSL15° LIFTING CAPACITIES · TRAGFÄHIGKEITEN · CAPACITÉS DE LEVAGE

170-250 t 0-80 t ZB 15-24 m 9,60 m 360° ISO

54 m + 84 m

m	SWSL							SFSL
	0 t		80 t-450 t					
	85°	85°	75°	65°	55°	45°	t	
26	-	157,0*	-	-	-	-	-	
28	-	156,5*	-	-	-	-	-	
30	-	155,0*	-	-	-	-	-	
32	120,0	156,5	-	-	-	-	-	
34	112,5	155,5	-	-	-	-	-	
38	99,7	154,0	-	-	-	-	152,0	
42	88,9	151,5	-	-	-	-	152,0	
46	78,2	149,5	-	-	-	-	152,0	
50	68,5	146,5	-	-	-	-	151,0	
54	60,4	144,0	146,5	-	-	-	150,0	
58	53,4	141,5	146,5	-	-	-	148,0	
62	47,4	136,0	146,5	-	-	-	146,0	
66	42,1	124,0	146,0	-	-	-	143,0	
70	37,5	113,5	141,5	-	-	-	141,0	
74	33,4	104,0	128,5	-	-	-	139,0	
78	29,7	95,7	117,5	130,5	-	-	136,0	
82	26,3	88,2	107,5	128,5	-	-	128,0	
86	23,3	81,4	99,1	120,5	-	-	118,0	
90	-	-	91,3	110,5	-	-	107,0	
94	-	-	84,3	101,5	-	-	97,0	
98	-	-	77,7	93,6	86,3	-	87,5	
102	-	-	-	86,4	81,3	-	78,5	
106	-	-	-	79,8	76,7	-	72,5	
110	-	-	-	-	72,4	-	66,0	
114	-	-	-	-	68,5	58,2	58,5	
118	-	-	-	-	-	54,9	51,0	
122	-	-	-	-	-	51,8	44,5	
126	-	-	-	-	-	-	40,7	
130	-	-	-	-	-	-	33,4	

54 m + 96 m

m	t	t	t	t	t	t	t
30	-	118,5*	-	-	-	-	-
34	105,5	117,0	-	-	-	-	-
38	93,5	116,0	-	-	-	-	114,0
42	83,2	114,5	-	-	-	-	113,0
46	74,3	112,5	-	-	-	-	113,0
50	66,2	110,5	-	-	-	-	112,0
54	58,0	108,5	-	-	-	-	111,0
58	51,0	106,5	-	-	-	-	110,0
62	45,0	104,0	106,0	-	-	-	108,0
66	39,7	102,0	106,0	-	-	-	107,0
70	35,1	99,9	105,5	-	-	-	105,0
74	30,9	97,0	104,5	-	-	-	103,0
78	27,2	93,2	103,5	-	-	-	101,0
82	23,9	87,1	102,5	-	-	-	99,0
86	20,9	80,4	97,8	92,8	-	-	97,0
90	18,1	74,3	90,1	92,8	-	-	95,5
94	15,6	68,7	83,1	92,8	-	-	93,5
98	13,3	63,5	76,8	92,2	-	-	91,5
102	-	-	71,1	85,1	-	-	83,5
106	-	-	65,8	78,6	73,6	-	75,5
110	-	-	-	72,8	69,5	-	68,0
114	-	-	-	67,4	65,9	-	62,5
118	-	-	-	62,4	62,6	-	57,5
122	-	-	-	-	59,5	48,4	51,0
126	-	-	-	-	56,6	45,5	44,6
130	-	-	-	-	-	42,8	38,4
134	-	-	-	-	-	40,3	34,1
138	-	-	-	-	-	-	29,5
142	-	-	-	-	-	-	23,1
146	-	-	-	-	-	-	-

54 m + 108 m

m	SWSL							SFSL
	0 t		80 t-450 t					
	85°	85°	75°	65°	55°	45°	t	
32	-	90,3*	-	-	-	-	-	
34	-	89,9*	-	-	-	-	-	
38	84,8	89,0	-	-	-	-	-	
42	77,6	88,0	-	-	-	-	86,5	
46	69,1	86,8	-	-	-	-	86,0	
50	61,9	85,5	-	-	-	-	85,5	
54	55,5	84,2	-	-	-	-	85,0	
58	48,9	82,8	-	-	-	-	83,5	
62	42,8	81,3	-	-	-	-	82,5	
66	37,5	79,9	79,1	-	-	-	81,5	
70	32,8	78,4	78,9	-	-	-	80,0	
74	28,7	77,0	78,6	-	-	-	78,5	
78	25,0	75,5	78,2	-	-	-	77,0	
82	21,6	73,3	77,7	-	-	-	75,5	
86	18,6	70,3	77,2	-	-	-	74,0	
90	15,8	67,3	76,7	67,7	-	-	72,5	
94	13,3	64,3	76,0	67,7	-	-	71,0	
98	11,0	61,3	75,1	67,7	-	-	70,0	
102	8,9	57,8	69,8	67,7	-	-	68,0	
106	6,9	53,5	64,6	67,7	-	-	67,0	
110	5,1	49,4	59,8	67,7	-	-	64,5	
114	-	-	55,4	66,1	59,0	-	62,5	
118	-	-	51,2	61,3	59,0	-	58,5	
122	-	-	-	56,7	57,1	-	53,5	
126	-	-	-	52,5	54,2	-	49,7	
130	-	-	-	48,6	51,4	-	43,8	
134	-	-	-	-	48,9	37,2	38,2	
138	-	-	-	-	46,5	34,8	32,7	
142	-	-	-	-	-	32,5	28,0	
146	-	-	-	-	-	-	25,2	
150	-	-	-	-	-	-	19,8	
154	-	-	-	-	-	-	14,2	
158	-	-	-	-	-	-	-	

### Remarks · Bemerkungen · Remarques

Main boom angle 87°, 85°, 75°, 65°, 55° and 45°; capacities for intermediate boom positions are calculated by the crane control system IC-1

Hauptauslegerwinkel 87°, 85°, 75°, 65°, 55° und 45°; Traglasten für Zwischenstellungen des Hauptauslegers werden von der Kransteuerung IC-1 berechnet

Jarret de flèche principale 87°, 85°, 75°, 65°, 55° et 45°; le système de commande de la grue IC-1 calcule les charges pour les positions intermédiaires de la flèche

\* Main boom angle 87°

Hauptauslegerwinkel 87°

Jarret de flèche principale 87°



# SWSL / SFSL15° LIFTING CAPACITIES · TRAGFÄHIGKEITEN · CAPACITÉS DE LEVAGE

170-250 t  
 0-80 tZB  
 15-24 m  
 9,60 m  
 360°  
 ISO

60 m + 36 m

m	SWSL							SFSL
	0 t		80 t-450 t					t
	85°	85°	75°	65°	55°	45°		
16	-	412,0*	-	-	-	-	-	
18	-	402,0*	-	-	-	-	-	
19	246,0	427,0	-	-	-	-	-	
20	234,0	427,0	-	-	-	-	396,0	
22	214,0	419,0	-	-	-	-	396,0	
24	197,5	410,0	-	-	-	-	396,0	
26	182,5	400,0	-	-	-	-	396,0	
28	168,0	383,0	-	-	-	-	396,0	
30	153,5	370,0	-	-	-	-	392,0	
34	130,5	309,0	-	-	-	-	386,0	
36	121,0	285,0	366,0	-	-	-	362,0	
38	112,5	264,0	346,0	-	-	-	338,0	
42	98,2	230,0	309,0	-	-	-	300,0	
46	-	-	278,0	-	-	-	268,0	
50	-	-	250,0	-	-	-	241,0	
53	-	-	-	226,0	-	-	223,7	
54	-	-	-	221,0	-	-	218,0	
58	-	-	-	204,0	-	-	198,0	
62	-	-	-	189,0	-	-	181,0	
66	-	-	-	-	164,5	-	164,0	
70	-	-	-	-	153,5	-	145,0	
74	-	-	-	-	-	-	128,0	
78	-	-	-	-	-	-	114,0	
82	-	-	-	-	-	-	103,0	
86	-	-	-	-	-	-	88,5	
90	-	-	-	-	-	-	76,5	
94	-	-	-	-	-	-	-	

60 m + 48 m

m	t	t	t	t	t	t	t
19	-	320,0*	-	-	-	-	-
20	-	318,0*	-	-	-	-	-
22	201,0	331,0	-	-	-	-	-
24	185,5	329,0	-	-	-	-	310,0
26	171,5	327,0	-	-	-	-	310,0
28	159,5	323,0	-	-	-	-	310,0
30	149,0	317,0	-	-	-	-	310,0
34	127,5	304,0	-	-	-	-	310,0
38	110,0	283,0	-	-	-	-	307,0
41	99,1	254,5	315,0	-	-	-	302,5
42	95,7	246,0	306,0	-	-	-	302,0
46	84,1	217,0	276,0	-	-	-	270,0
50	74,5	192,5	250,0	-	-	-	243,0
54	66,3	171,5	229,0	-	-	-	220,0
58	-	-	207,0	201,0	-	-	200,0
62	-	-	185,0	186,0	-	-	183,0
66	-	-	-	173,0	-	-	167,0
70	-	-	-	161,0	-	-	154,0
74	-	-	-	151,0	138,5	-	140,0
78	-	-	-	-	130,0	-	125,0
82	-	-	-	-	122,0	-	111,0
86	-	-	-	-	-	98,8	99,0
90	-	-	-	-	-	93,4	91,0
94	-	-	-	-	-	-	79,5
98	-	-	-	-	-	-	68,0

60 m + 60 m

m	SWSL							SFSL
	0 t		80 t-450 t					t
	85°	85°	75°	65°	55°	45°		
22	-	248,0*	-	-	-	-	-	
24	-	247,0*	-	-	-	-	-	
26	161,5	254,0	-	-	-	-	-	
28	150,0	254,0	-	-	-	-	244,0	
30	140,0	254,0	-	-	-	-	244,0	
34	123,5	250,0	-	-	-	-	244,0	
38	109,5	243,0	-	-	-	-	244,0	
42	96,4	236,0	-	-	-	-	244,0	
46	84,4	221,0	250,0	-	-	-	242,0	
50	74,5	196,0	248,0	-	-	-	234,0	
54	66,1	175,5	231,0	-	-	-	224,0	
58	59,0	158,0	211,0	-	-	-	204,0	
62	52,8	143,0	188,5	-	-	-	186,0	
66	47,3	128,0	169,0	173,0	-	-	171,0	
70	-	-	152,5	161,0	-	-	157,0	
74	-	-	138,5	150,5	-	-	145,0	
78	-	-	-	141,5	-	-	134,0	
82	-	-	-	133,0	120,5	-	123,0	
86	-	-	-	125,0	113,0	-	110,0	
90	-	-	-	-	106,0	-	99,0	
94	-	-	-	-	100,0	-	88,0	
98	-	-	-	-	-	81,9	80,5	
102	-	-	-	-	-	77,6	72,0	
106	-	-	-	-	-	-	62,5	
110	-	-	-	-	-	-	53,0	

60 m + 72 m

m	t	t	t	t	t	t	t
24	-	193,0*	-	-	-	-	-
26	-	192,0*	-	-	-	-	-
28	140,0	195,5	-	-	-	-	-
30	131,0	195,5	-	-	-	-	-
34	115,0	193,5	-	-	-	-	188,0
38	102,0	190,5	-	-	-	-	188,0
42	90,2	187,0	-	-	-	-	188,0
46	78,8	183,0	-	-	-	-	188,0
50	69,3	179,0	-	-	-	-	188,0
54	61,3	171,5	186,0	-	-	-	186,0
58	54,4	154,5	185,5	-	-	-	180,0
62	48,5	140,0	184,5	-	-	-	175,0
66	43,2	127,5	165,5	-	-	-	171,0
70	38,6	116,5	149,5	-	-	-	157,0
74	34,5	106,5	135,5	145,0	-	-	145,0
78	-	-	123,5	136,0	-	-	134,0
82	-	-	113,0	127,5	-	-	124,0
86	-	-	103,5	120,5	-	-	115,0
90	-	-	-	113,5	100,5	-	104,0
94	-	-	-	107,5	94,7	-	94,0
98	-	-	-	100,0	89,2	-	84,0
102	-	-	-	-	84,2	-	75,0
106	-	-	-	-	79,6	68,0	68,5
110	-	-	-	-	-	64,1	62,0
114	-	-	-	-	-	60,5	54,0
118	-	-	-	-	-	-	46,2
122	-	-	-	-	-	-	40,6

**Remarks · Bemerkungen · Remarques:** \* Main boom angle 87° · Hauptauslegerwinkel 87° · Jarret de flèche principale 87°  
 Main boom angle 87°, 85°, 75°, 65°, 55° and 45°; capacities for intermediate boom positions are calculated by the crane control system IC-1  
 Hauptauslegerwinkel 87°, 85°, 75°, 65°, 55° und 45°; Traglasten für Zwischenstellungen des Hauptauslegers werden von der Kransteuerung IC-1 berechnet  
 Jarret de flèche principale 87°, 85°, 75°, 65°, 55° et 45°; le système de commande de la grue IC-1 calcule les charges pour les positions intermédiaires de la flèche

# SWSL / SFSL15° LIFTING CAPACITIES · TRAGFÄHIGKEITEN · CAPACITÉS DE LEVAGE

170-250 t 0-80 t ZB 15-24 m 9,60 m 360° ISO

60 m + 84 m

m	SWSL						SFSL
	0 t		80 t-450 t				
	85°	85°	75°	65°	55°	45°	t
28	-	148,5*	-	-	-	-	-
30	-	147,5*	-	-	-	-	-
32	115,5	149,0	-	-	-	-	-
34	108,0	149,0	-	-	-	-	-
38	95,9	147,5	-	-	-	-	144,0
42	85,5	145,5	-	-	-	-	144,0
46	76,6	143,5	-	-	-	-	144,0
50	67,1	141,0	-	-	-	-	144,0
54	59,1	138,5	-	-	-	-	144,0
58	52,2	136,5	140,0	-	-	-	143,0
62	46,3	134,0	139,5	-	-	-	140,0
66	41,0	127,0	139,5	-	-	-	138,0
70	36,5	116,0	139,0	-	-	-	135,0
74	32,4	106,5	135,0	-	-	-	133,0
78	28,7	97,9	123,0	124,0	-	-	131,0
82	25,4	90,2	112,5	124,0	-	-	125,0
86	22,4	83,2	103,5	118,0	-	-	116,0
90	-	-	95,4	111,5	-	-	107,0
94	-	-	88,0	105,5	-	-	99,5
98	-	-	81,2	99,7	86,0	-	90,5
102	-	-	-	92,0	81,0	-	81,5
106	-	-	-	84,9	76,5	-	73,0
110	-	-	-	-	72,2	-	65,0
114	-	-	-	-	68,3	-	59,5
118	-	-	-	-	64,6	53,9	54,5
122	-	-	-	-	-	50,8	47,6
126	-	-	-	-	-	47,9	40,8
130	-	-	-	-	-	-	34,2
134	-	-	-	-	-	-	30,8

60 m + 96 m

m	SWSL						SFSL
	0 t		80 t-450 t				
	85°	85°	75°	65°	55°	45°	t
30	-	112,5*	-	-	-	-	-
34	-	111,0*	-	-	-	-	-
36	95,4	112,0	-	-	-	-	-
38	89,7	111,5	-	-	-	-	-
42	79,8	110,0	-	-	-	-	108,0
46	71,3	108,5	-	-	-	-	108,0
50	64,0	106,5	-	-	-	-	108,0
54	56,7	105,0	-	-	-	-	107,0
58	49,8	103,0	-	-	-	-	106,0
62	43,8	101,0	101,5	-	-	-	105,0
66	38,6	99,0	101,5	-	-	-	103,0
70	34,0	97,0	101,5	-	-	-	101,0
74	29,9	94,6	101,5	-	-	-	100,0
78	26,3	91,5	100,5	-	-	-	98,0
82	23,0	88,3	99,7	-	-	-	96,5
86	20,0	82,2	98,5	88,7	-	-	94,5
90	17,3	76,0	94,1	88,7	-	-	93,0
94	14,8	70,3	86,8	88,7	-	-	91,0
98	12,6	65,0	80,2	88,7	-	-	89,0
102	-	-	74,2	88,7	-	-	86,0
106	-	-	68,7	83,7	-	-	78,0
110	-	-	63,5	77,5	69,0	-	70,5
114	-	-	-	71,7	65,1	-	63,0
118	-	-	-	66,4	61,4	-	56,0
122	-	-	-	-	58,0	-	51,0
126	-	-	-	-	54,8	44,5	47,0
130	-	-	-	-	51,8	41,8	41,1
134	-	-	-	-	-	39,3	35,1
138	-	-	-	-	-	37,0	29,3
142	-	-	-	-	-	-	25,8
146	-	-	-	-	-	-	20,8

## Remarks · Bemerkungen · Remarques

Main boom angle 87°, 85°, 75°, 65°, 55° and 45°; capacities for intermediate boom positions are calculated by the crane control system IC-1

Hauptauslegerwinkel 87°, 85°, 75°, 65°, 55° und 45°; Traglasten für Zwischenstellungen des Hauptauslegers werden von der Kransteuerung IC-1 berechnet

Jarret de flèche principale 87°, 85°, 75°, 65°, 55° et 45°; le système de commande de la grue IC-1 calcule les charges pour les positions intermédiaires de la flèche

\* Main boom angle 87° · Hauptauslegerwinkel 87° · Jarret de flèche principale 87°

# SWSL / SFSL15<sup>o</sup> LIFTING CAPACITIES · TRAGFÄHIGKEITEN · CAPACITÉS DE LEVAGE

170-250 t  
 0-80 t ZB  
 15-24 m  
 9,60 m  
 360°  
 ISO

60 m + 108 m

m	SWSL						SFSL
	0 t		80 t-450 t				
	85°	85°	75°	65°	55°	45°	t
32	-	84,4*	-	-	-	-	-
34	-	84,1*	-	-	-	-	-
38	79,3	83,2	-	-	-	-	-
42	74,3	82,4	-	-	-	-	-
46	66,1	81,2	-	-	-	-	80,5
50	59,1	80,0	-	-	-	-	80,0
54	53,0	78,8	-	-	-	-	79,5
58	47,6	77,5	-	-	-	-	78,5
62	41,7	76,1	-	-	-	-	77,5
66	36,4	74,7	73,4	-	-	-	76,0
70	31,8	73,4	73,3	-	-	-	75,0
74	27,7	72,0	73,1	-	-	-	73,5
78	24,0	70,7	72,9	-	-	-	72,5
82	20,7	68,7	72,6	-	-	-	71,0
86	17,7	66,0	72,1	-	-	-	69,5
90	15,0	63,1	71,5	-	-	-	68,5
94	12,5	60,3	71,0	62,6	-	-	67,0
98	10,3	57,4	70,2	62,6	-	-	65,5
102	8,2	54,5	68,9	62,6	-	-	64,0
106	6,2	51,7	66,9	62,6	-	-	63,0
110	-	48,8	62,5	62,6	-	-	61,5
114	-	-	57,9	62,6	-	-	59,0
118	-	-	53,6	62,6	54,4	-	56,5
122	-	-	49,5	60,5	54,3	-	54,0
126	-	-	-	56,0	51,9	-	48,3
130	-	-	-	51,9	48,9	-	43,4
134	-	-	-	-	46,1	-	39,8
138	-	-	-	-	43,4	33,8	34,9
142	-	-	-	-	41,1	31,5	29,6
146	-	-	-	-	-	29,4	24,5
150	-	-	-	-	-	27,4	20,1
154	-	-	-	-	-	-	17,0
158	-	-	-	-	-	-	12,1

66 m + 36 m

m	SWSL							SFSL
	85°	85°	75°	65°	55°	45°		t
16	-	379,0*	-	-	-	-	-	-
18	-	374,0*	-	-	-	-	-	-
20	225,0	389,0	-	-	-	-	-	368,0
22	206,0	385,0	-	-	-	-	-	368,0
24	190,0	378,0	-	-	-	-	-	368,0
26	176,0	369,0	-	-	-	-	-	368,0
28	164,0	360,0	-	-	-	-	-	363,0
30	151,5	351,0	-	-	-	-	-	363,0
34	128,5	316,0	-	-	-	-	-	356,0
38	110,5	269,0	341,0	-	-	-	-	335,0
42	96,6	233,0	305,0	-	-	-	-	297,0
46	-	-	275,0	-	-	-	-	265,0
50	-	-	250,0	-	-	-	-	238,0
54	-	-	229,0	217,0	-	-	-	215,0
58	-	-	-	200,0	-	-	-	195,0
62	-	-	-	185,0	-	-	-	178,0
66	-	-	-	-	-	-	-	162,0
70	-	-	-	-	151,0	-	-	149,0
74	-	-	-	-	141,5	-	-	134,0
78	-	-	-	-	-	-	-	118,0
82	-	-	-	-	-	-	-	104,0
86	-	-	-	-	-	-	-	94,5
90	-	-	-	-	-	-	-	82,5
94	-	-	-	-	-	-	-	69,5
98	-	-	-	-	-	-	-	-
102	-	-	-	-	-	-	-	-

66 m + 48 m

m	SWSL						SFSL
	0 t		80 t-450 t				
	85°	85°	75°	65°	55°	45°	t
19	-	297,0*	-	-	-	-	-
20	-	297,0*	-	-	-	-	-
22	-	293,0*	-	-	-	-	-
24	178,5	305,0	-	-	-	-	290,0
26	165,5	303,0	-	-	-	-	290,0
28	154,0	299,0	-	-	-	-	290,0
30	144,0	294,0	-	-	-	-	290,0
34	126,0	283,0	-	-	-	-	290,0
38	108,0	272,0	-	-	-	-	283,0
42	94,1	250,0	302,0	-	-	-	280,0
46	82,6	220,0	273,0	-	-	-	268,0
50	73,0	196,0	248,0	-	-	-	240,0
54	65,0	173,0	226,0	-	-	-	217,0
58	-	-	208,0	-	-	-	197,0
62	-	-	193,0	182,0	-	-	180,0
66	-	-	174,0	169,0	-	-	164,0
70	-	-	-	157,5	-	-	151,0
74	-	-	-	147,5	-	-	139,0
78	-	-	-	-	128,5	-	128,0
82	-	-	-	-	120,5	-	115,0
86	-	-	-	-	113,5	-	103,0
90	-	-	-	-	-	88,9	91,0
94	-	-	-	-	-	84,1	81,5
98	-	-	-	-	-	-	74,0
102	-	-	-	-	-	-	63,5
106	-	-	-	-	-	-	53,0
110	-	-	-	-	-	-	-

66 m + 60 m

m	SWSL							SFSL
	85°	85°	75°	65°	55°	45°		t
22	-	233,0*	-	-	-	-	-	-
24	-	232,0*	-	-	-	-	-	-
26	155,5	238,0	-	-	-	-	-	-
28	144,5	238,0	-	-	-	-	-	229,0
30	135,0	237,0	-	-	-	-	-	229,0
34	119,0	234,0	-	-	-	-	-	229,0
38	106,0	228,0	-	-	-	-	-	229,0
42	94,9	221,0	-	-	-	-	-	226,0
46	83,0	214,0	-	-	-	-	-	224,0
48	77,9	210,0	235,0	-	-	-	-	223,0
50	73,2	202,0	233,0	-	-	-	-	222,0
54	64,9	186,5	228,0	-	-	-	-	213,0
58	57,8	168,5	210,0	-	-	-	-	201,0
62	51,7	150,0	194,0	-	-	-	-	184,0
66	46,3	127,0	180,0	-	-	-	-	168,0
70	-	-	166,5	157,5	-	-	-	154,0
74	-	-	152,0	147,5	-	-	-	142,0
78	-	-	133,5	138,0	-	-	-	131,0
82	-	-	-	130,0	-	-	-	121,0
86	-	-	-	122,5	112,0	-	-	112,0
90	-	-	-	-	105,0	-	-	102,0
94	-	-	-	-	99,2	-	-	91,5
98	-	-	-	-	93,7	-	-	81,5
102	-	-	-	-	-	73,5	-	71,5
106	-	-	-	-	-	69,8	-	66,0
110	-	-	-	-	-	-	-	58,0
114	-	-	-	-	-	-	-	49,3
118	-	-	-	-	-	-	-	41,9

Remarks · Bemerkungen · Remarques  
 see page 34 · siehe Seite 34 · voir page 34

# SWSL / SFSL15° LIFTING CAPACITIES · TRAGFÄHIGKEITEN · CAPACITÉS DE LEVAGE

170-250 t 0-80 t ZB 15-24 m 9,60 m 360° ISO

66 m + 72 m

m	SWSL						SFSL
	0 t		80 t-450 t				
	85°	85°	75°	65°	55°	45°	t
24	-	182,5*	-	-	-	-	-
26	-	182,0*	-	-	-	-	-
28	-	180,5*	-	-	-	-	-
30	126,0	184,5	-	-	-	-	-
34	110,5	182,5	-	-	-	-	178,0
38	98,1	180,0	-	-	-	-	178,0
42	87,7	177,0	-	-	-	-	178,0
46	77,5	173,5	-	-	-	-	178,0
50	68,1	169,5	-	-	-	-	178,0
54	60,1	166,0	177,0	-	-	-	177,0
58	53,3	161,0	176,5	-	-	-	171,0
62	47,4	151,0	175,5	-	-	-	167,0
66	42,2	137,5	174,0	-	-	-	163,0
70	37,7	124,0	162,0	-	-	-	155,0
74	33,6	109,0	149,5	141,5	-	-	143,0
78	29,9	93,0	136,5	132,5	-	-	131,0
82	-	-	125,0	124,5	-	-	121,0
86	-	-	114,5	117,5	-	-	112,0
90	-	-	-	111,0	-	-	104,0
94	-	-	-	105,0	93,5	-	96,5
98	-	-	-	99,6	88,1	-	86,5
102	-	-	-	-	83,1	-	77,5
106	-	-	-	-	78,5	-	69,0
110	-	-	-	-	74,2	61,5	61,0
114	-	-	-	-	-	58,4	56,0
118	-	-	-	-	-	55,6	49,9
122	-	-	-	-	-	-	42,5
126	-	-	-	-	-	-	35,0
130	-	-	-	-	-	-	30,7

66 m + 84 m

m	t	t	t	t	t	t
28	-	141,0*	-	-	-	-
30	-	140,0*	-	-	-	-
32	110,5	141,5	-	-	-	-
34	104,0	141,5	-	-	-	-
38	92,1	140,0	-	-	-	137,0
42	82,1	138,5	-	-	-	137,0
46	73,6	136,5	-	-	-	137,0
50	65,8	134,5	-	-	-	137,0
54	57,9	132,0	-	-	-	137,0
58	51,1	130,0	133,5	-	-	137,0
62	45,2	127,5	133,5	-	-	135,0
66	40,0	125,5	133,5	-	-	132,0
70	35,5	123,5	133,0	-	-	129,0
74	31,5	115,0	132,5	-	-	127,0
78	27,8	105,5	132,0	-	-	125,0
82	24,6	95,8	124,0	118,5	-	122,0
86	21,6	84,7	114,0	115,0	-	113,0
90	-	-	105,0	108,5	-	105,0
94	-	-	97,3	102,5	-	97,5
98	-	-	89,7	97,4	-	90,5
102	-	-	-	92,3	79,8	83,5
106	-	-	-	87,7	75,3	75,0
110	-	-	-	83,4	71,1	67,5
114	-	-	-	-	67,2	60,0
118	-	-	-	-	63,5	53,0
122	-	-	-	-	60,1	48,1
126	-	-	-	-	-	46,3
130	-	-	-	-	-	43,5
134	-	-	-	-	-	43,7
138	-	-	-	-	-	30,8
142	-	-	-	-	-	25,8

66 m + 96 m

m	SWSL						SFSL
	0 t		80 t-450 t				
	85°	85°	75°	65°	55°	45°	t
30	-	107,0*	-	-	-	-	-
34	-	106,0*	-	-	-	-	-
36	91,3	106,5	-	-	-	-	-
38	86,0	106,5	-	-	-	-	-
42	76,4	105,0	-	-	-	-	104,0
46	68,3	103,5	-	-	-	-	103,0
50	61,2	102,0	-	-	-	-	103,0
54	55,1	100,5	-	-	-	-	103,0
58	48,7	98,8	-	-	-	-	102,0
62	42,8	96,9	97,8	-	-	-	101,0
66	37,6	95,1	97,8	-	-	-	100,0
70	33,1	93,2	97,8	-	-	-	98,0
74	29,0	91,1	97,7	-	-	-	96,5
78	25,4	88,7	97,2	-	-	-	95,0
82	22,2	86,1	96,5	-	-	-	93,5
86	19,2	83,5	95,4	-	-	-	91,5
90	16,5	81,0	94,5	85,1	-	-	90,0
94	14,1	74,5	93,5	85,1	-	-	88,5
98	11,8	65,9	88,9	85,0	-	-	86,5
102	-	-	82,4	85,0	-	-	84,5
106	-	-	76,4	85,0	-	-	78,0
110	-	-	70,4	81,1	67,8	-	71,5
114	-	-	-	77,1	63,9	-	64,5
118	-	-	-	73,4	60,3	-	58,0
122	-	-	-	69,9	56,9	-	51,5
126	-	-	-	-	53,7	-	45,5
130	-	-	-	-	50,8	40,2	40,7
134	-	-	-	-	-	37,7	37,1
138	-	-	-	-	-	35,4	31,6
142	-	-	-	-	-	33,2	26,1
146	-	-	-	-	-	-	20,6
150	-	-	-	-	-	-	16,7
154	-	-	-	-	-	-	-

## Remarks · Bemerkungen · Remarques

Main boom angle 87°, 85°, 75°, 65°, 55° and 45°; capacities for intermediate boom positions are calculated by the crane control system IC-1

Hauptauslegerwinkel 87°, 85°, 75°, 65°, 55° und 45°; Traglasten für Zwischenstellungen des Hauptauslegers werden von der Kransteuerung IC-1 berechnet

Jarret de flèche principale 87°, 85°, 75°, 65°, 55° et 45°; le système de commande de la grue IC-1 calcule les charges pour les positions intermédiaires de la flèche

\* Main boom angle 87°  
Hauptauslegerwinkel 87°  
Jarret de flèche principale 87°

**SWSL / SFSL15° LIFTING CAPACITIES · TRAGFÄHIGKEITEN · CAPACITÉS DE LEVAGE**

66 m + 108 m

m	SWSL						SFSL
	0 t		80 t-450 t				
	85°	85°	75°	65°	55°	45°	t
32	-	80,2*	-	-	-	-	-
34	-	80,2*	-	-	-	-	-
38	75,8	79,3	-	-	-	-	-
42	70,9	78,8	-	-	-	-	-
46	63,1	77,9	-	-	-	-	77,0
50	56,3	76,8	-	-	-	-	76,5
54	50,4	75,8	-	-	-	-	76,0
58	45,2	74,6	-	-	-	-	75,5
62	40,6	73,3	-	-	-	-	74,5
66	35,4	72,0	-	-	-	-	73,5
70	30,9	70,7	70,3	-	-	-	72,5
74	26,8	69,5	70,3	-	-	-	71,5
78	23,2	68,2	70,2	-	-	-	70,5
82	19,9	66,5	70,1	-	-	-	69,0
86	17,0	64,2	69,8	-	-	-	67,5
90	14,3	61,7	69,3	-	-	-	66,5
94	11,8	59,3	68,9	-	-	-	65,0
98	9,6	56,8	68,2	59,9	-	-	64,0
102	7,5	54,3	67,4	59,9	-	-	62,5
106	5,6	51,9	66,0	59,9	-	-	61,5
110	-	49,4	64,4	59,9	-	-	60,0
114	-	-	62,7	59,9	-	-	58,0
118	-	-	60,2	59,9	-	-	56,0
122	-	-	55,3	59,9	51,9	-	53,5
126	-	-	-	59,9	50,7	-	49,6
130	-	-	-	59,4	47,8	-	43,9
134	-	-	-	55,2	45,0	-	38,4
138	-	-	-	-	42,4	-	34,0
142	-	-	-	-	39,9	29,9	30,7
146	-	-	-	-	-	27,9	26,2
150	-	-	-	-	-	25,9	21,4
154	-	-	-	-	-	24,1	16,5
158	-	-	-	-	-	-	11,7
162	-	-	-	-	-	-	8,7
166	-	-	-	-	-	-	-

**Remarks · Bemerkungen · Remarques**

Main boom angle 87°, 85°, 75°, 65°, 55° and 45°; capacities for intermediate boom positions are calculated by the crane control system IC-1  
 Hauptauslegerwinkel 87°, 85°, 75°, 65°, 55° und 45°; Traglasten für Zwischenstellungen des Hauptauslegers werden von der Kransteuerung IC-1 berechnet

Jarret de flèche principale 87°, 85°, 75°, 65°, 55° et 45°; le système de commande de la grue IC-1 calcule les charges pour les positions intermédiaires de la flèche

\* Main boom angle 87°  
 Hauptauslegerwinkel 87°  
 Jarret de flèche principale 87°

72 m + 36 m

m	SWSL						SFSL
	0 t		80 t-450 t				
	85°	85°	75°	65°	55°	45°	t
16	-	346,0*	-	-	-	-	-
18	-	343,0*	-	-	-	-	-
20	216,0	355,0	-	-	-	-	336,0
22	198,0	353,0	-	-	-	-	336,0
24	182,5	347,0	-	-	-	-	336,0
26	169,5	339,0	-	-	-	-	336,0
28	157,5	331,0	-	-	-	-	336,0
30	147,5	323,0	-	-	-	-	331,0
34	126,0	307,0	-	-	-	-	327,0
38	108,5	274,0	-	-	-	-	324,0
40	101,0	254,0	317,0	-	-	-	308,5
42	94,7	237,0	301,0	-	-	-	293,0
44	88,5	222,0	286,0	-	-	-	277,0
46	-	-	271,0	-	-	-	261,0
50	-	-	247,0	-	-	-	234,0
54	-	-	226,0	-	-	-	211,0
58	-	-	-	195,5	-	-	191,0
62	-	-	-	180,5	-	-	174,0
66	-	-	-	168,0	-	-	159,0
70	-	-	-	-	-	-	145,0
74	-	-	-	-	136,5	-	133,0
78	-	-	-	-	128,0	-	121,0
82	-	-	-	-	-	-	107,0
86	-	-	-	-	-	-	94,5
90	-	-	-	-	-	-	83,0
94	-	-	-	-	-	-	75,5
98	-	-	-	-	-	-	63,5

72 m + 48 m

m	t	t	t	t	t	t	t
19	-	274,0*	-	-	-	-	-
20	-	274,0*	-	-	-	-	-
22	-	270,0*	-	-	-	-	-
24	171,5	281,0	-	-	-	-	266,0
26	159,0	279,0	-	-	-	-	266,0
28	148,0	276,0	-	-	-	-	266,0
30	138,5	271,0	-	-	-	-	266,0
34	122,0	262,0	-	-	-	-	266,0
38	106,0	251,0	-	-	-	-	262,0
42	92,1	241,0	-	-	-	-	259,0
44	86,2	230,0	279,0	-	-	-	255,0
46	80,8	223,0	269,0	-	-	-	253,0
50	71,3	198,5	244,0	-	-	-	237,0
54	63,4	178,0	223,0	-	-	-	214,0
58	-	-	205,0	-	-	-	194,0
62	-	-	190,0	-	-	-	177,0
66	-	-	176,5	165,0	-	-	161,0
70	-	-	-	153,5	-	-	147,0
74	-	-	-	144,0	-	-	135,0
78	-	-	-	135,0	-	-	124,0
82	-	-	-	-	117,0	-	115,0
86	-	-	-	-	110,5	-	104,0
90	-	-	-	-	104,0	-	93,0
94	-	-	-	-	-	-	82,5
98	-	-	-	-	-	-	72,0
102	-	-	-	-	-	-	65,5
106	-	-	-	-	-	-	57,5
110	-	-	-	-	-	-	47,9
114	-	-	-	-	-	-	-

3

# SWSL / SFSL15° LIFTING CAPACITIES · TRAGFÄHIGKEITEN · CAPACITÉS DE LEVAGE

170-250 t 0-80 t ZB 15-24 m 9,60 m 360° ISO

72 m + 60 m

m	SWSL							SFSL
	0 t		80 t-450 t					
	85°	85°	75°	65°	55°	45°	t	
22	-	217,0*	-	-	-	-	-	
24	-	216,0*	-	-	-	-	-	
26	149,0	221,0	-	-	-	-	-	
28	139,0	221,0	-	-	-	-	212,0	
30	129,5	220,0	-	-	-	-	212,0	
34	114,5	217,0	-	-	-	-	212,0	
38	101,5	212,0	-	-	-	-	212,0	
42	91,4	205,0	-	-	-	-	212,0	
46	81,3	199,0	-	-	-	-	209,0	
50	71,6	192,5	220,0	-	-	-	207,0	
54	63,5	181,5	217,0	-	-	-	199,0	
58	56,5	170,5	207,0	-	-	-	193,0	
62	50,4	153,5	191,0	-	-	-	181,0	
66	45,1	131,0	177,5	-	-	-	165,0	
70	-	-	165,0	153,0	-	-	151,0	
74	-	-	154,5	143,0	-	-	139,0	
78	-	-	143,0	134,5	-	-	128,0	
82	-	-	-	126,5	-	-	118,0	
86	-	-	-	119,0	-	-	109,0	
90	-	-	-	112,5	102,0	-	100,0	
94	-	-	-	-	96,5	-	93,0	
98	-	-	-	-	91,0	-	83,0	
102	-	-	-	-	86,0	-	73,5	
106	-	-	-	-	-	64,5	64,5	
110	-	-	-	-	-	61,3	57,5	
114	-	-	-	-	-	-	52,0	
118	-	-	-	-	-	-	44,2	
122	-	-	-	-	-	-	36,0	
126	-	-	-	-	-	-	-	

72 m + 72 m

m	t	t	t	t	t	t	t
26	-	170,5*	-	-	-	-	-
28	-	169,5*	-	-	-	-	-
30	120,5	172,5	-	-	-	-	-
34	106,0	171,5	-	-	-	-	167,0
38	94,2	169,5	-	-	-	-	167,0
42	84,1	166,5	-	-	-	-	167,0
46	75,6	163,0	-	-	-	-	167,0
50	66,6	159,5	-	-	-	-	167,0
54	58,7	156,0	167,0	-	-	-	166,0
58	52,0	152,5	166,0	-	-	-	162,0
62	46,2	147,5	165,5	-	-	-	157,0
66	41,1	139,5	164,5	-	-	-	153,0
70	36,6	126,5	159,5	-	-	-	149,0
74	32,5	111,5	149,0	-	-	-	140,0
78	28,9	95,9	140,0	129,0	-	-	129,0
82	-	-	130,0	121,0	-	-	118,0
86	-	-	119,0	114,0	-	-	109,0
90	-	-	105,5	107,5	-	-	101,0
94	-	-	-	102,0	-	-	93,5
98	-	-	-	96,7	85,4	-	86,5
102	-	-	-	91,7	80,5	-	78,5
106	-	-	-	-	76,0	-	70,0
110	-	-	-	-	71,8	-	62,5
114	-	-	-	-	67,9	53,4	54,5
118	-	-	-	-	-	50,7	48,5
122	-	-	-	-	-	48,2	44,2
126	-	-	-	-	-	-	37,5
130	-	-	-	-	-	-	30,6
134	-	-	-	-	-	-	24,6
138	-	-	-	-	-	-	-

72 m + 84 m

m	SWSL							SFSL
	0 t		80 t-450 t					
	85°	85°	75°	65°	55°	45°	t	
28	-	132,0*	-	-	-	-	-	
30	-	131,5*	-	-	-	-	-	
34	99,5	133,0	-	-	-	-	-	
38	88,1	131,5	-	-	-	-	129,0	
42	78,5	130,0	-	-	-	-	129,0	
46	70,4	128,5	-	-	-	-	129,0	
50	63,4	126,5	-	-	-	-	129,0	
54	56,5	124,0	-	-	-	-	129,0	
58	49,8	122,0	-	-	-	-	129,0	
62	43,9	120,0	125,5	-	-	-	129,0	
66	38,9	117,5	125,5	-	-	-	124,0	
70	34,4	115,5	125,0	-	-	-	121,0	
74	30,4	113,5	124,5	-	-	-	119,0	
78	26,8	107,5	124,0	-	-	-	117,0	
82	23,6	97,7	123,5	-	-	-	114,0	
86	20,7	86,6	118,5	111,5	-	-	110,0	
90	18,0	74,7	109,0	105,5	-	-	102,0	
94	-	-	100,5	99,7	-	-	94,5	
98	-	-	93,2	94,4	-	-	87,5	
102	-	-	83,0	89,5	-	-	81,0	
106	-	-	-	85,0	72,6	-	75,0	
110	-	-	-	80,8	68,5	-	68,0	
114	-	-	-	76,9	64,7	-	60,5	
118	-	-	-	-	61,1	-	53,5	
122	-	-	-	-	57,8	-	47,3	
126	-	-	-	-	-	42,1	41,2	
130	-	-	-	-	-	40,0	37,3	
134	-	-	-	-	-	38,0	32,3	
138	-	-	-	-	-	-	26,4	
142	-	-	-	-	-	-	20,5	
146	-	-	-	-	-	-	15,7	

## Remarks · Bemerkungen · Remarques

Main boom angle 87°, 85°, 75°, 65°, 55° and 45°; capacities for intermediate boom positions are calculated by the crane control system IC-1

Hauptauslegerwinkel 87°, 85°, 75°, 65°, 55° und 45°; Traglasten für Zwischenstellungen des Hauptauslegers werden von der Kransteuerung IC-1 berechnet

Jarret de flèche principale 87°, 85°, 75°, 65°, 55° et 45°; le système de commande de la grue IC-1 calcule les charges pour les positions intermédiaires de la flèche

\* Main boom angle 87°  
Hauptauslegerwinkel 87°  
Jarret de flèche principale 87°

**SWSL / SFSL15° LIFTING CAPACITIES · TRAGFÄHIGKEITEN · CAPACITÉS DE LEVAGE**

170-250 t 0-80 t ZB 15-24 m 9,60 m 360° ISO

72 m + 96 m

72 m + 108 m

m	SWSL							SFSL
	0 t		80 t-450 t					
	85°	85°	75°	65°	55°	45°	t	
30	-	101,5*	-	-	-	-	-	
34	-	100,5*	-	-	-	-	-	
36	87,2	101,0	-	-	-	-	-	
38	82,0	101,0	-	-	-	-	-	
42	72,8	100,0	-	-	-	-	98,5	
46	65,0	98,9	-	-	-	-	98,5	
50	58,3	97,6	-	-	-	-	98,5	
54	52,4	96,0	-	-	-	-	98,5	
58	47,2	94,2	-	-	-	-	97,5	
62	41,5	92,4	-	-	-	-	97,0	
66	36,4	90,7	93,2	-	-	-	96,0	
70	32,0	88,9	93,2	-	-	-	94,5	
74	28,0	87,0	93,2	-	-	-	92,5	
78	24,4	85,1	93,1	-	-	-	91,0	
82	21,2	83,1	92,5	-	-	-	89,5	
86	18,3	81,2	91,9	-	-	-	88,0	
90	15,7	79,2	90,9	80,9	-	-	87,0	
94	13,2	75,9	90,2	80,9	-	-	85,0	
98	11,0	67,4	89,4	80,7	-	-	83,5	
102	8,9	58,1	85,3	80,7	-	-	81,5	
106	-	-	79,1	80,7	-	-	75,5	
110	-	-	73,4	78,3	-	-	69,5	
114	-	-	65,2	74,5	61,3	-	64,5	
118	-	-	-	70,8	57,8	-	58,0	
122	-	-	-	67,5	54,5	-	51,5	
126	-	-	-	64,4	51,4	-	45,9	
130	-	-	-	-	48,5	-	40,1	
134	-	-	-	-	45,8	34,3	34,5	
138	-	-	-	-	-	32,4	30,9	
142	-	-	-	-	-	30,5	27,0	
146	-	-	-	-	-	28,6	21,8	
150	-	-	-	-	-	-	16,7	
154	-	-	-	-	-	-	11,4	
158	-	-	-	-	-	-	7,6	
162	-	-	-	-	-	-	-	

m	SWSL							SFSL
	0 t		80 t-450 t					
	85°	85°	75°	65°	55°	45°	t	
34	-	76,3*	-	-	-	-	-	
38	-	75,2*	-	-	-	-	-	
40	71,2	75,4	-	-	-	-	-	
42	67,4	75,2	-	-	-	-	-	
46	59,9	74,3	-	-	-	-	73,5	
50	53,4	73,4	-	-	-	-	73,0	
54	47,7	72,4	-	-	-	-	72,5	
58	42,7	71,3	-	-	-	-	72,5	
62	38,3	70,2	-	-	-	-	71,5	
66	34,2	68,9	-	-	-	-	70,5	
70	29,7	67,7	67,0	-	-	-	70,0	
74	25,7	66,5	67,0	-	-	-	69,0	
78	22,2	65,2	67,0	-	-	-	67,5	
82	18,9	63,8	67,0	-	-	-	66,5	
86	16,0	61,9	66,9	-	-	-	65,0	
90	13,4	59,8	66,6	-	-	-	64,0	
94	11,0	57,7	66,3	-	-	-	63,0	
98	8,7	55,7	66,0	56,9	-	-	62,0	
102	6,7	53,6	65,3	56,9	-	-	60,5	
106	-	51,5	64,5	56,9	-	-	59,5	
110	-	49,4	63,3	56,8	-	-	58,0	
114	-	-	62,0	56,8	-	-	57,0	
118	-	-	60,9	56,8	-	-	55,0	
122	-	-	57,9	56,7	49,0	-	52,5	
126	-	-	51,1	56,7	48,3	-	49,5	
130	-	-	-	56,7	45,4	-	43,9	
134	-	-	-	55,6	42,7	-	38,5	
138	-	-	-	53,1	40,2	-	33,4	
142	-	-	-	-	37,8	-	28,5	
146	-	-	-	-	35,5	25,2	26,0	
150	-	-	-	-	-	23,3	21,8	
154	-	-	-	-	-	-	21,6	
158	-	-	-	-	-	-	19,9	
162	-	-	-	-	-	-	8,1	
166	-	-	-	-	-	-	-	

3

**Remarks · Bemerkungen · Remarques**

Main boom angle 87°, 85°, 75°, 65°, 55° and 45°; capacities for intermediate boom positions are calculated by the crane control system IC-1  
 Hauptauslegerwinkel 87°, 85°, 75°, 65°, 55° und 45°; Traglasten für Zwischenstellungen des Hauptauslegers werden von der Kransteuerung IC-1 berechnet  
 Jarret de flèche principale 87°, 85°, 75°, 65°, 55° et 45°; le système de commande de la grue IC-1 calcule les charges pour les positions intermédiaires de la flèche

\* Main boom angle 87° · Hauptauslegerwinkel 87° · Jarret de flèche principale 87°

# SWSL / SFSL15° LIFTING CAPACITIES · TRAGFÄHIGKEITEN · CAPACITÉS DE LEVAGE

170-250 t 0-80 tZB 15-24 m 9,60 m 360° ISO

78 m + 36 m

m	SWSL							SFSL
	0 t		80 t-450 t					
	85°	85°	75°	65°	55°	45°	t	
17	-	313,0*	-	-	-	-	-	
18	-	313,0*	-	-	-	-	-	
20	-	308,0*	-	-	-	-	-	
22	190,0	321,0	-	-	-	-	307,0	
24	175,5	317,0	-	-	-	-	307,0	
26	162,5	312,0	-	-	-	-	307,0	
28	151,5	305,0	-	-	-	-	307,0	
30	142,0	298,0	-	-	-	-	307,0	
34	124,0	284,0	-	-	-	-	303,0	
38	106,5	271,0	-	-	-	-	299,0	
40	99,4	259,0	312,0	-	-	-	293,0	
42	92,8	241,0	296,0	-	-	-	290,0	
44	86,7	225,0	282,0	-	-	-	274,0	
46	-	-	268,0	-	-	-	258,0	
50	-	-	243,0	-	-	-	231,0	
54	-	-	222,0	-	-	-	208,0	
58	-	-	205,0	190,5	-	-	188,0	
62	-	-	-	176,5	-	-	171,0	
66	-	-	-	164,0	-	-	156,0	
70	-	-	-	153,0	-	-	142,0	
74	-	-	-	-	-	-	130,0	
78	-	-	-	-	123,5	-	119,0	
82	-	-	-	-	116,0	-	109,0	
86	-	-	-	-	-	-	97,0	
90	-	-	-	-	-	-	85,0	
94	-	-	-	-	-	-	74,0	
98	-	-	-	-	-	-	66,5	
102	-	-	-	-	-	-	57,5	
106	-	-	-	-	-	-	-	

78 m + 60 m

m	SWSL							SFSL
	0 t		80 t-450 t					
	85°	85°	75°	65°	55°	45°	t	
22	-	201,0*	-	-	-	-	-	
24	-	200,0*	-	-	-	-	-	
26	-	198,5*	-	-	-	-	-	
28	133,0	205,0	-	-	-	-	-	
30	124,5	204,0	-	-	-	-	196,0	
34	110,0	200,0	-	-	-	-	196,0	
38	97,9	196,0	-	-	-	-	196,0	
42	87,8	190,5	-	-	-	-	196,0	
46	79,3	184,5	-	-	-	-	195,0	
50	70,1	179,0	203,0	-	-	-	194,0	
54	62,0	173,5	201,0	-	-	-	188,0	
58	55,1	165,5	200,0	-	-	-	181,0	
62	49,2	156,5	188,5	-	-	-	175,0	
66	43,9	134,5	174,5	-	-	-	162,0	
70	-	-	163,0	-	-	-	149,0	
74	-	-	152,0	138,5	-	-	136,0	
78	-	-	142,5	130,0	-	-	125,0	
82	-	-	-	122,5	-	-	115,0	
86	-	-	-	116,0	-	-	106,0	
90	-	-	-	109,5	-	-	98,0	
94	-	-	-	103,5	92,5	-	90,0	
98	-	-	-	-	87,8	-	83,0	
102	-	-	-	-	82,9	-	74,5	
106	-	-	-	-	78,4	-	66,0	
110	-	-	-	-	-	57,5	58,0	
114	-	-	-	-	-	54,3	50,0	
118	-	-	-	-	-	-	45,4	
122	-	-	-	-	-	-	39,0	
126	-	-	-	-	-	-	31,5	

78 m + 48 m

m	t	t	t	t	t	t	t
19	-	252,0*	-	-	-	-	-
20	-	252,0*	-	-	-	-	-
22	-	249,0*	-	-	-	-	-
24	164,5	257,0	-	-	-	-	-
26	152,5	256,0	-	-	-	-	245,0
28	142,0	253,0	-	-	-	-	245,0
30	133,0	250,0	-	-	-	-	245,0
34	117,5	242,0	-	-	-	-	245,0
38	104,0	233,0	-	-	-	-	245,0
42	90,2	224,0	-	-	-	-	242,0
46	79,0	215,0	255,0	-	-	-	238,0
50	69,7	201,0	241,0	-	-	-	228,0
54	61,8	180,0	220,0	-	-	-	211,0
58	-	-	202,0	-	-	-	191,0
62	-	-	187,5	-	-	-	174,0
66	-	-	174,0	160,5	-	-	158,0
70	-	-	-	149,5	-	-	145,0
74	-	-	-	140,0	-	-	132,0
78	-	-	-	131,5	-	-	121,0
82	-	-	-	123,5	-	-	111,0
86	-	-	-	-	105,5	-	102,0
90	-	-	-	-	100,0	-	94,5
94	-	-	-	-	94,9	-	84,0
98	-	-	-	-	-	-	74,0
102	-	-	-	-	-	-	64,5
106	-	-	-	-	-	-	57,0
110	-	-	-	-	-	-	51,0
114	-	-	-	-	-	-	42,7
118	-	-	-	-	-	-	-
122	-	-	-	-	-	-	-

78 m + 72 m

m	t	t	t	t	t	t	t
26	-	159,5*	-	-	-	-	-
28	-	158,5*	-	-	-	-	-
30	115,5	161,5	-	-	-	-	-
34	101,5	161,0	-	-	-	-	156,0
38	90,2	159,0	-	-	-	-	156,0
42	80,6	156,5	-	-	-	-	156,0
46	72,4	153,5	-	-	-	-	156,0
50	65,1	150,0	-	-	-	-	156,0
54	57,3	146,5	-	-	-	-	156,0
58	50,7	143,5	156,5	-	-	-	154,0
62	44,9	139,5	156,0	-	-	-	148,0
66	39,9	136,0	154,5	-	-	-	144,0
70	35,5	128,5	153,5	-	-	-	140,0
74	31,5	114,0	147,0	-	-	-	137,0
78	27,9	98,6	137,5	-	-	-	126,0
82	-	-	129,5	118,0	-	-	116,0
86	-	-	122,0	111,0	-	-	107,0
90	-	-	112,0	104,5	-	-	98,5
94	-	-	-	99,1	-	-	91,0
98	-	-	-	93,9	-	-	83,5
102	-	-	-	89,0	77,3	-	77,0
106	-	-	-	-	72,9	-	70,5
110	-	-	-	-	68,9	-	63,0
114	-	-	-	-	65,1	-	55,5
118	-	-	-	-	-	-	48,6
122	-	-	-	-	-	43,5	41,8
126	-	-	-	-	-	41,3	37,4
130	-	-	-	-	-	-	32,4
134	-	-	-	-	-	-	26,1
138	-	-	-	-	-	-	19,7



**SWSL / SFSL15° LIFTING CAPACITIES · TRAGFÄHIGKEITEN · CAPACITÉS DE LEVAGE**

170-250 t 0-80 t ZB 15-24 m 9,60 m 360° ISO

78 m + 84 m

m	SWSL						SFSL
	0 t		80 t-450 t				
	85°	85°	75°	65°	55°	45°	t
28	-	124,5*	-	-	-	-	-
30	-	124,0*	-	-	-	-	-
34	95,1	125,0	-	-	-	-	-
38	84,2	124,0	-	-	-	-	121,0
42	75,0	123,0	-	-	-	-	121,0
46	67,2	121,5	-	-	-	-	121,0
50	60,5	119,5	-	-	-	-	121,0
54	54,6	117,5	-	-	-	-	121,0
58	48,4	115,5	-	-	-	-	121,0
62	42,7	113,5	119,5	-	-	-	121,0
66	37,7	111,5	119,0	-	-	-	118,0
70	33,3	109,5	119,0	-	-	-	115,0
74	29,3	107,0	118,0	-	-	-	112,0
78	25,8	105,0	118,0	-	-	-	110,0
82	22,7	99,4	117,0	-	-	-	108,0
86	19,8	88,4	117,0	105,5	-	-	106,0
90	17,2	76,7	113,0	102,0	-	-	100,0
94	-	-	104,0	96,6	-	-	92,0
98	-	-	96,4	91,4	-	-	85,0
102	-	-	87,8	86,7	-	-	78,5
106	-	-	-	82,3	-	-	72,0
110	-	-	-	78,2	65,5	-	66,5
114	-	-	-	74,4	61,8	-	60,5
118	-	-	-	-	58,3	-	54,0
122	-	-	-	-	55,1	-	47,6
126	-	-	-	-	52,1	-	41,5
130	-	-	-	-	-	35,5	35,5
134	-	-	-	-	-	33,6	31,3
138	-	-	-	-	-	31,8	27,4
142	-	-	-	-	-	-	21,9
146	-	-	-	-	-	-	16,4
150	-	-	-	-	-	-	10,8
154	-	-	-	-	-	-	-

78 m + 96 m

m	SWSL						SFSL
	0 t		80 t-450 t				
	85°	85°	75°	65°	55°	45°	t
30	-	95,9*	-	-	-	-	-
34	-	95,2*	-	-	-	-	-
36	83,2	95,9	-	-	-	-	-
38	78,1	95,9	-	-	-	-	-
42	69,4	94,9	-	-	-	-	93,0
46	61,9	93,8	-	-	-	-	93,0
50	55,4	92,5	-	-	-	-	93,0
54	49,7	91,1	-	-	-	-	93,0
58	44,7	89,4	-	-	-	-	92,5
62	40,3	87,8	-	-	-	-	92,0
66	35,3	86,1	88,7	-	-	-	91,5
70	30,9	84,4	88,7	-	-	-	90,5
74	26,9	82,8	88,7	-	-	-	88,5
78	23,4	81,2	88,7	-	-	-	87,0
82	20,2	79,6	88,2	-	-	-	85,5
86	17,4	78,0	87,7	-	-	-	84,5
90	14,8	76,4	86,8	-	-	-	83,0
94	12,4	74,8	86,4	77,0	-	-	81,5
98	10,2	68,8	85,8	76,7	-	-	80,5
102	8,2	59,7	84,3	76,7	-	-	79,0
106	-	-	81,8	76,7	-	-	73,0
110	-	-	75,8	75,1	-	-	67,5
114	-	-	69,0	71,3	-	-	62,0
118	-	-	-	67,8	54,9	-	57,0
122	-	-	-	64,5	51,7	-	51,5
126	-	-	-	61,5	48,7	-	45,7
130	-	-	-	-	45,9	-	40,0
134	-	-	-	-	43,2	-	34,6
138	-	-	-	-	40,8	29,0	29,3
142	-	-	-	-	-	27,5	26,3
146	-	-	-	-	-	25,6	22,2
150	-	-	-	-	-	23,8	17,4
154	-	-	-	-	-	-	12,6
158	-	-	-	-	-	-	7,7
162	-	-	-	-	-	-	-

3

**Remarks · Bemerkungen · Remarques**

Main boom angle 87°, 85°, 75°, 65°, 55° and 45°; capacities for intermediate boom positions are calculated by the crane control system IC-1  
 Hauptauslegerwinkel 87°, 85°, 75°, 65°, 55° und 45°; Traglasten für Zwischenstellungen des Hauptauslegers werden von der Kransteuerung IC-1 berechnet  
 Jarret de flèche principale 87°, 85°, 75°, 65°, 55° et 45°; le système de commande de la grue IC-1 calcule les charges pour les positions intermédiaires de la flèche

\* Main boom angle 87° · Hauptauslegerwinkel 87° · Jarret de flèche principale 87°

# SWSL / SFSL15° LIFTING CAPACITIES · TRAGFÄHIGKEITEN · CAPACITÉS DE LEVAGE

170-250 t 0-80 t ZB 15-24 m 9,60 m 360° ISO

78 m + 108 m

m	SWSL						SFSL
	80 t-450 t						
	0 t	85°	85°	75°	65°	55°	45°
34	-	72,1*	-	-	-	-	-
38	-	71,4*	-	-	-	-	-
40	67,3	71,5	-	-	-	-	-
42	63,9	71,4	-	-	-	-	-
46	56,7	70,7	-	-	-	-	69,5
50	50,5	69,8	-	-	-	-	69,5
54	45,0	68,9	-	-	-	-	69,0
58	40,2	67,9	-	-	-	-	69,0
62	35,9	66,8	-	-	-	-	68,5
66	32,1	65,6	-	-	-	-	67,5
70	28,6	64,5	-	-	-	-	67,0
74	24,7	63,3	63,8	-	-	-	66,0
78	21,2	62,1	63,8	-	-	-	65,0
82	18,0	60,8	63,8	-	-	-	63,5
86	15,1	59,3	63,8	-	-	-	62,5
90	12,5	57,6	63,7	-	-	-	61,5
94	10,1	55,9	63,5	-	-	-	60,5
98	7,9	54,2	63,3	-	-	-	59,5
102	5,9	52,5	62,8	54,2	-	-	58,5
106	-	50,8	62,4	54,2	-	-	57,5
110	-	49,1	61,7	54,1	-	-	56,0
114	-	46,2	60,7	54,1	-	-	55,0
118	-	-	59,9	54,1	-	-	54,0
122	-	-	59,2	54,0	-	-	51,5
126	-	-	54,2	54,0	45,5	-	48,6
130	-	-	-	54,0	42,7	-	43,3
134	-	-	-	52,9	40,1	-	38,1
138	-	-	-	50,4	37,6	-	33,1
142	-	-	-	-	35,3	-	28,2
146	-	-	-	-	33,1	-	24,1
150	-	-	-	-	31,0	20,3	21,6
154	-	-	-	-	-	18,7	17,2
158	-	-	-	-	-	17,1	12,9
162	-	-	-	-	-	15,5	8,7
166	-	-	-	-	-	-	-

## Remarks · Bemerkungen · Remarques

Main boom angle 87°, 85°, 75°, 65°, 55° and 45°; capacities for intermediate boom positions are calculated by the crane control system IC-1

Hauptauslegerwinkel 87°, 85°, 75°, 65°, 55° und 45°; Traglasten für Zwischenstellungen des Hauptauslegers werden von der Kransteuerung IC-1 berechnet

Jarret de flèche principale 87°, 85°, 75°, 65°, 55° et 45°; le système de commande de la grue IC-1 calcule les charges pour les positions intermédiaires de la flèche

\* Main boom angle 87°  
Hauptauslegerwinkel 87°  
Jarret de flèche principale 87°

84 m + 36 m

m	SWSL						SFSL
	80 t-450 t						
	0 t	85°	85°	75°	65°	55°	45°
17	-	285,0*	-	-	-	-	-
18	-	285,0*	-	-	-	-	-
20	-	281,0*	-	-	-	-	-
22	181,5	292,0	-	-	-	-	279,0
24	168,0	288,0	-	-	-	-	279,0
26	156,0	284,0	-	-	-	-	279,0
28	145,5	278,0	-	-	-	-	279,0
30	136,0	273,0	-	-	-	-	279,0
34	120,5	261,0	-	-	-	-	277,0
38	104,5	251,0	-	-	-	-	272,0
42	90,7	240,0	287,0	-	-	-	268,0
44	84,8	229,0	277,0	-	-	-	261,5
46	-	-	264,0	-	-	-	255,0
50	-	-	239,0	-	-	-	228,0
54	-	-	219,0	-	-	-	205,0
58	-	-	201,0	-	-	-	185,0
62	-	-	-	171,0	-	-	168,0
66	-	-	-	159,5	-	-	152,0
70	-	-	-	148,5	-	-	139,0
74	-	-	-	-	-	-	127,0
78	-	-	-	-	117,5	-	116,0
82	-	-	-	-	110,5	-	106,0
86	-	-	-	-	105,0	-	97,0
90	-	-	-	-	-	-	86,0
94	-	-	-	-	-	-	75,5
98	-	-	-	-	-	-	65,0
102	-	-	-	-	-	-	57,5
106	-	-	-	-	-	-	50,5
110	-	-	-	-	-	-	41,1

84 m + 48 m

m	t	t	t	t	t	t	t
20	-	229,0*	-	-	-	-	-
22	-	227,0*	-	-	-	-	-
24	157,0	233,0	-	-	-	-	-
26	146,0	233,0	-	-	-	-	224,0
28	136,0	231,0	-	-	-	-	224,0
30	127,5	228,0	-	-	-	-	224,0
34	112,5	221,0	-	-	-	-	224,0
38	100,5	214,0	-	-	-	-	224,0
42	88,1	206,0	-	-	-	-	221,0
46	77,0	199,5	-	-	-	-	218,0
48	72,2	196,0	230,0	-	-	-	213,5
50	67,9	192,5	230,0	-	-	-	211,0
54	60,1	180,0	216,0	-	-	-	204,0
58	-	-	199,0	-	-	-	188,0
62	-	-	184,0	-	-	-	170,0
66	-	-	171,0	-	-	-	155,0
70	-	-	159,5	144,5	-	-	141,0
74	-	-	-	135,5	-	-	129,0
78	-	-	-	127,5	-	-	118,0
82	-	-	-	120,0	-	-	108,0
86	-	-	-	-	-	-	99,5
90	-	-	-	-	94,6	-	91,0
94	-	-	-	-	89,7	-	83,5
98	-	-	-	-	-	-	74,0
102	-	-	-	-	-	-	65,0
106	-	-	-	-	-	-	56,5
110	-	-	-	-	-	-	48,6
114	-	-	-	-	-	-	43,9
118	-	-	-	-	-	-	36,5
122	-	-	-	-	-	-	28,6

**SWSL / SFSL15° LIFTING CAPACITIES · TRAGFÄHIGKEITEN · CAPACITÉS DE LEVAGE**

170-250 t 0-80 t ZB 15-24 m 9,60 m 360° ISO

84 m + 60 m

m	SWSL						SFSL
	0 t		80 t-450 t				
	85°	85°	75°	65°	55°	45°	t
24	-	184,0*	-	-	-	-	-
26	-	182,5*	-	-	-	-	-
28	127,0	187,5	-	-	-	-	-
30	119,0	187,0	-	-	-	-	180,0
34	105,0	184,0	-	-	-	-	180,0
38	93,6	179,5	-	-	-	-	180,0
42	84,0	175,0	-	-	-	-	180,0
46	75,8	170,0	-	-	-	-	180,0
50	68,4	165,0	-	-	-	-	177,0
54	60,4	160,0	185,5	-	-	-	174,0
58	53,6	155,5	183,0	-	-	-	169,0
62	47,7	150,5	181,5	-	-	-	163,0
66	42,6	138,0	172,0	-	-	-	159,0
70	-	-	160,0	-	-	-	146,0
74	-	-	149,5	-	-	-	133,0
78	-	-	140,0	125,5	-	-	122,0
82	-	-	132,0	118,0	-	-	112,0
86	-	-	-	111,5	-	-	103,0
90	-	-	-	105,5	-	-	95,0
94	-	-	-	100,0	-	-	87,0
98	-	-	-	-	82,6	-	80,0
102	-	-	-	-	78,4	-	73,5
106	-	-	-	-	74,4	-	66,0
110	-	-	-	-	-	-	58,0
114	-	-	-	-	-	50,0	50,5
118	-	-	-	-	-	47,1	43,2
122	-	-	-	-	-	-	38,0
126	-	-	-	-	-	-	33,0
130	-	-	-	-	-	-	26,1
134	-	-	-	-	-	-	19,1
138	-	-	-	-	-	-	-

84 m + 72 m

m	SWSL						SFSL
	0 t		80 t-450 t				
	85°	85°	75°	65°	55°	45°	t
26	-	147,5*	-	-	-	-	-
28	-	147,0*	-	-	-	-	-
30	-	145,5*	-	-	-	-	-
32	103,0	150,0	-	-	-	-	-
34	97,0	149,0	-	-	-	-	144,0
38	86,0	147,0	-	-	-	-	144,0
42	76,8	144,5	-	-	-	-	144,0
46	69,0	141,5	-	-	-	-	144,0
50	62,3	138,5	-	-	-	-	144,0
54	55,8	135,0	-	-	-	-	144,0
58	49,2	132,0	147,0	-	-	-	142,0
62	43,6	128,5	145,5	-	-	-	139,0
66	38,6	125,5	145,5	-	-	-	134,0
70	34,2	122,0	143,0	-	-	-	131,0
74	30,3	116,0	142,0	-	-	-	128,0
78	26,8	101,0	135,0	-	-	-	123,0
82	-	-	127,0	113,5	-	-	113,0
86	-	-	119,5	107,0	-	-	104,0
90	-	-	113,0	101,0	-	-	95,5
94	-	-	102,5	95,7	-	-	88,0
98	-	-	-	90,7	-	-	81,0
102	-	-	-	86,0	-	-	74,0
106	-	-	-	81,6	68,9	-	68,0
110	-	-	-	-	65,0	-	62,0
114	-	-	-	-	61,3	-	55,0
118	-	-	-	-	58,0	-	48,3
122	-	-	-	-	-	-	41,7
126	-	-	-	-	-	36,5	35,4
130	-	-	-	-	-	34,3	31,2
134	-	-	-	-	-	-	26,7
138	-	-	-	-	-	-	20,8
142	-	-	-	-	-	-	14,9
146	-	-	-	-	-	-	-

**Remarks · Bemerkungen · Remarques**

Main boom angle 87°, 85°, 75°, 65°, 55° and 45°; capacities for intermediate boom positions are calculated by the crane control system IC-1

Hauptauslegerwinkel 87°, 85°, 75°, 65°, 55° und 45°; Traglasten für Zwischenstellungen des Hauptauslegers werden von der Kransteuerung IC-1 berechnet

Jarret de flèche principale 87°, 85°, 75°, 65°, 55° et 45°; le système de commande de la grue IC-1 calcule les charges pour les positions intermédiaires de la flèche

\* Main boom angle 87° · Hauptauslegerwinkel 87° · Jarret de flèche principale 87°

3

# SWSL / SFSL15<sup>o</sup> LIFTING CAPACITIES · TRAGFÄHIGKEITEN · CAPACITÉS DE LEVAGE

170-250 t 0-80 t ZB 15-24 m 9,60 m 360° ISO

84 m + 84 m

m	SWSL							SFSL
	0 t		80 t-450 t					
	85°	85°	75°	65°	55°	45°	t	
28	-	117,0*	-	-	-	-	-	
30	-	116,5*	-	-	-	-	-	
34	90,5	117,5	-	-	-	-	-	
38	80,1	117,0	-	-	-	-	114,0	
42	71,3	115,5	-	-	-	-	114,0	
46	63,8	114,0	-	-	-	-	114,0	
50	57,3	112,5	-	-	-	-	114,0	
54	51,7	110,5	-	-	-	-	114,0	
58	46,7	108,5	-	-	-	-	114,0	
62	41,3	106,5	112,5	-	-	-	114,0	
66	36,4	104,5	112,5	-	-	-	112,0	
70	32,0	102,5	112,0	-	-	-	109,0	
74	28,2	100,0	111,0	-	-	-	106,0	
78	24,7	98,0	111,0	-	-	-	103,0	
82	21,6	95,8	111,0	-	-	-	101,0	
86	18,8	90,1	110,0	-	-	-	99,5	
90	16,2	78,6	109,5	97,8	-	-	97,0	
94	-	-	105,0	92,4	-	-	89,5	
98	-	-	99,5	87,4	-	-	82,0	
102	-	-	92,1	82,8	-	-	75,5	
106	-	-	80,8	78,6	-	-	69,5	
110	-	-	-	74,7	-	-	63,5	
114	-	-	-	71,0	57,9	-	58,5	
118	-	-	-	67,7	54,5	-	52,5	
122	-	-	-	-	51,4	-	46,7	
126	-	-	-	-	48,5	-	40,8	
130	-	-	-	-	45,8	-	35,0	
134	-	-	-	-	-	29,7	29,5	
138	-	-	-	-	-	28,2	26,3	
142	-	-	-	-	-	26,8	21,9	
146	-	-	-	-	-	-	16,7	
150	-	-	-	-	-	-	11,6	
154	-	-	-	-	-	-	6,4	

84 m + 96 m

m	SWSL							SFSL
	0 t		80 t-450 t					
	85°	85°	75°	65°	55°	45°	t	
32	-	88,9*	-	-	-	-	-	
34	-	88,2*	-	-	-	-	-	
38	74,1	88,6	-	-	-	-	-	
42	65,7	87,8	-	-	-	-	86,0	
46	58,5	86,8	-	-	-	-	86,0	
50	52,3	85,6	-	-	-	-	86,0	
54	46,9	84,3	-	-	-	-	86,0	
58	42,1	82,7	-	-	-	-	85,5	
62	37,8	81,0	-	-	-	-	85,0	
66	34,0	79,4	-	-	-	-	84,5	
70	29,6	77,8	81,7	-	-	-	84,0	
74	25,8	76,1	81,7	-	-	-	82,0	
78	22,3	74,5	81,7	-	-	-	79,5	
82	19,2	72,9	81,6	-	-	-	78,5	
86	16,4	71,2	80,8	-	-	-	77,0	
90	13,8	69,6	80,3	-	-	-	76,0	
94	11,5	67,9	79,3	-	-	-	74,5	
98	9,3	66,3	78,7	70,7	-	-	73,5	
102	7,3	61,3	77,8	70,3	-	-	72,0	
106	-	-	76,8	70,3	-	-	70,5	
110	-	-	75,3	70,3	-	-	64,5	
114	-	-	72,6	67,8	-	-	59,0	
118	-	-	-	64,4	-	-	54,0	
122	-	-	-	61,2	47,9	-	49,7	
126	-	-	-	58,3	45,1	-	44,4	
130	-	-	-	55,5	42,4	-	38,9	
134	-	-	-	-	39,8	-	33,7	
138	-	-	-	-	37,5	-	28,6	
142	-	-	-	-	35,2	23,6	24,2	
146	-	-	-	-	-	21,8	21,5	
150	-	-	-	-	-	20,1	16,9	
154	-	-	-	-	-	18,5	12,4	
158	-	-	-	-	-	-	7,9	

## Remarks · Bemerkungen · Remarques

Main boom angle 87°, 85°, 75°, 65°, 55° and 45°; capacities for intermediate boom positions are calculated by the crane control system IC-1

Hauptauslegerwinkel 87°, 85°, 75°, 65°, 55° und 45°; Traglasten für Zwischenstellungen des Hauptauslegers werden von der Kransteuerung IC-1 berechnet

Jarret de flèche principale 87°, 85°, 75°, 65°, 55° et 45°; le système de commande de la grue IC-1 calcule les charges pour les positions intermédiaires de la flèche

\* Main boom angle 87° · Hauptauslegerwinkel 87° · Jarret de flèche principale 87°

**SWSL / SFSL15° LIFTING CAPACITIES · TRAGFÄHIGKEITEN · CAPACITÉS DE LEVAGE**

170-250 t 0-80 t ZB 15-24 m 9,60 m 360° ISO

84 m + 108 m

90 m + 36 m

m	SWSL							SFSL
	0 t		80 t-450 t					
	85°	85°	75°	65°	55°	45°	t	
34	-	68,0*	-	-	-	-	-	
38	-	67,3*	-	-	-	-	-	
40	63,2	67,5	-	-	-	-	-	
42	60,3	67,5	-	-	-	-	-	
46	53,4	66,8	-	-	-	-	65,5	
50	47,4	66,0	-	-	-	-	65,5	
54	42,2	65,2	-	-	-	-	65,5	
58	37,6	64,2	-	-	-	-	65,0	
62	33,5	63,1	-	-	-	-	65,0	
66	29,8	62,0	-	-	-	-	64,0	
70	26,5	60,9	-	-	-	-	63,5	
74	23,5	59,8	60,4	-	-	-	63,0	
78	20,1	58,7	60,4	-	-	-	62,0	
82	16,9	57,5	60,4	-	-	-	60,5	
86	14,1	56,3	60,4	-	-	-	59,5	
90	11,5	54,9	60,4	-	-	-	58,5	
94	9,2	53,6	60,3	-	-	-	57,5	
98	7,1	52,2	60,2	-	-	-	56,5	
102	5,1	50,9	59,6	51,1	-	-	55,5	
106	-	49,5	59,4	50,9	-	-	54,5	
110	-	48,2	59,2	50,9	-	-	53,5	
114	-	46,8	58,5	50,9	-	-	52,5	
118	-	-	58,2	50,9	-	-	51,5	
122	-	-	57,8	50,7	-	-	50,0	
126	-	-	57,1	50,7	-	-	46,0	
130	-	-	-	50,7	39,1	-	41,8	
134	-	-	-	49,9	36,6	-	36,8	
138	-	-	-	47,5	34,2	-	31,9	
142	-	-	-	45,2	32,0	-	27,1	
146	-	-	-	-	29,9	-	22,6	
150	-	-	-	-	27,9	-	19,1	
154	-	-	-	-	26,0	15,0	15,7	
158	-	-	-	-	-	13,5	12,1	
162	-	-	-	-	-	12,0	8,1	
166	-	-	-	-	-	10,7	-	

m	SWSL							SFSL
	0 t		80 t-450 t					
	85°	85°	75°	65°	55°	45°	t	
17	-	260,0*	-	-	-	-	-	
18	-	260,0*	-	-	-	-	-	
20	-	256,0*	-	-	-	-	-	
22	174,0	264,0	-	-	-	-	254,0	
24	161,0	262,0	-	-	-	-	254,0	
26	149,5	258,0	-	-	-	-	254,0	
28	139,5	254,0	-	-	-	-	254,0	
30	130,5	249,0	-	-	-	-	254,0	
34	115,5	239,0	-	-	-	-	254,0	
38	102,0	230,0	-	-	-	-	251,0	
42	88,6	223,0	-	-	-	-	248,0	
44	82,8	219,0	258,0	-	-	-	241,5	
46	-	-	257,0	-	-	-	238,0	
50	-	-	236,0	-	-	-	225,0	
54	-	-	216,0	-	-	-	202,0	
58	-	-	198,5	-	-	-	182,0	
62	-	-	-	-	-	-	164,0	
66	-	-	-	154,0	-	-	149,0	
70	-	-	-	144,0	-	-	135,0	
74	-	-	-	135,0	-	-	123,0	
78	-	-	-	-	-	-	112,0	
82	-	-	-	-	104,5	-	103,0	
86	-	-	-	-	99,1	-	94,0	
90	-	-	-	-	-	-	86,0	
94	-	-	-	-	-	-	76,0	
98	-	-	-	-	-	-	66,0	
102	-	-	-	-	-	-	56,5	
106	-	-	-	-	-	-	48,8	
110	-	-	-	-	-	-	43,6	
114	-	-	-	-	-	-	35,2	
118	-	-	-	-	-	-	-	

3

**Remarks · Bemerkungen · Remarques**

Main boom angle 87°, 85°, 75°, 65°, 55° and 45°; capacities for intermediate boom positions are calculated by the crane control system IC-1  
 Hauptauslegerwinkel 87°, 85°, 75°, 65°, 55° und 45°; Traglasten für Zwischenstellungen des Hauptauslegers werden von der Kransteuerung IC-1 berechnet  
 Jarret de flèche principale 87°, 85°, 75°, 65°, 55° et 45°; le système de commande de la grue IC-1 calcule les charges pour les positions intermédiaires de la flèche

\* Main boom angle 87° · Hauptauslegerwinkel 87° · Jarret de flèche principale 87°

# SWSL / SFSL15° LIFTING CAPACITIES · TRAGFÄHIGKEITEN · CAPACITÉS DE LEVAGE

 170-250 t  
 
 0-80 t ZB  
 
 15-24 m  
 
 9,60 m  
 
 360°  
 
 ISO

 90 m + 48 m

m	SWSL						SFSL
	0 t		80 t-450 t				
	85°	85°	75°	65°	55°	45°	t
20	-	209,0*	-	-	-	-	-
22	-	208,0*	-	-	-	-	-
24	-	206,0*	-	-	-	-	-
26	139,5	213,0	-	-	-	-	204,0
28	130,5	211,0	-	-	-	-	204,0
30	122,0	208,0	-	-	-	-	204,0
34	108,0	203,0	-	-	-	-	204,0
38	96,4	196,0	-	-	-	-	204,0
42	86,0	189,0	-	-	-	-	204,0
46	75,1	183,0	-	-	-	-	202,0
48	70,4	180,0	210,0	-	-	-	198,0
50	66,0	177,5	210,0	-	-	-	197,0
54	58,4	171,5	205,0	-	-	-	189,0
58	-	-	196,0	-	-	-	183,0
62	-	-	181,0	-	-	-	167,0
66	-	-	168,0	-	-	-	152,0
70	-	-	156,5	139,0	-	-	138,0
74	-	-	-	130,5	-	-	126,0
78	-	-	-	122,5	-	-	115,0
82	-	-	-	115,5	-	-	105,0
86	-	-	-	109,0	-	-	96,0
90	-	-	-	-	88,9	-	88,0
94	-	-	-	-	84,3	-	80,5
98	-	-	-	-	80,0	-	73,5
102	-	-	-	-	-	-	65,0
106	-	-	-	-	-	-	56,5
110	-	-	-	-	-	-	48,8
114	-	-	-	-	-	-	41,2
118	-	-	-	-	-	-	36,4
122	-	-	-	-	-	-	30,5
126	-	-	-	-	-	-	23,3

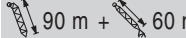
 90 m + 60 m

m	SWSL						SFSL
	0 t		80 t-450 t				
	85°	85°	75°	65°	55°	45°	t
24	-	169,0*	-	-	-	-	-
26	-	167,5*	-	-	-	-	-
28	121,5	171,5	-	-	-	-	-
30	113,5	171,5	-	-	-	-	165,0
34	100,5	168,5	-	-	-	-	165,0
38	89,5	164,5	-	-	-	-	165,0
42	80,3	160,0	-	-	-	-	165,0
46	72,4	155,5	-	-	-	-	165,0
50	65,7	150,5	-	-	-	-	165,0
54	58,9	146,5	169,5	-	-	-	163,0
58	52,2	142,5	168,0	-	-	-	157,0
62	46,4	138,5	164,5	-	-	-	152,0
66	41,3	134,5	162,0	-	-	-	147,0
70	-	-	157,5	-	-	-	143,0
74	-	-	147,0	-	-	-	130,0
78	-	-	138,0	120,5	-	-	119,0
82	-	-	129,5	113,5	-	-	109,0
86	-	-	-	107,0	-	-	100,0
90	-	-	-	101,0	-	-	92,0
94	-	-	-	96,1	-	-	84,5
98	-	-	-	91,3	-	-	77,0
102	-	-	-	-	73,5	-	70,5
106	-	-	-	-	69,8	-	64,5
110	-	-	-	-	66,3	-	57,5
114	-	-	-	-	-	-	50,0
118	-	-	-	-	-	42,7	43,3
122	-	-	-	-	-	40,2	36,6
126	-	-	-	-	-	-	31,9
130	-	-	-	-	-	-	27,1
134	-	-	-	-	-	-	20,8
138	-	-	-	-	-	-	14,4

### Remarks · Bemerkungen · Remarques

Main boom angle 87°, 85°, 75°, 65°, 55° and 45°; capacities for intermediate boom positions are calculated by the crane control system IC-1  
 Hauptauslegerwinkel 87°, 85°, 75°, 65°, 55° und 45°; Traglasten für Zwischenstellungen des Hauptauslegers werden von der Kransteuerung IC-1 berechnet  
 Jarret de flèche principale 87°, 85°, 75°, 65°, 55° et 45°; le système de commande de la grue IC-1 calcule les charges pour les positions intermédiaires de la flèche

\* Main boom angle 87° · Hauptauslegerwinkel 87° · Jarret de flèche principale 87°

**SWSL / SFSL15° LIFTING CAPACITIES · TRAGFÄHIGKEITEN · CAPACITÉS DE LEVAGE**

170-250 t 0-80 t ZB 15-24 m 9,60 m 360° ISO

90 m + 72 m

90 m + 84 m

m	SWSL						SFSL
	0 t		80 t-450 t				
	85°	85°	75°	65°	55°	45°	t
26	-	135,5*	-	-	-	-	-
28	-	135,0*	-	-	-	-	-
30	-	134,0*	-	-	-	-	-
32	98,4	137,5	-	-	-	-	-
34	92,3	137,0	-	-	-	-	132,0
38	81,9	135,5	-	-	-	-	132,0
42	73,1	133,0	-	-	-	-	132,0
46	65,6	130,0	-	-	-	-	132,0
50	59,2	127,0	-	-	-	-	132,0
54	53,5	123,5	-	-	-	-	132,0
58	47,8	120,5	134,5	-	-	-	132,0
62	42,2	117,5	134,5	-	-	-	129,0
66	37,3	114,5	133,0	-	-	-	125,0
70	33,0	112,0	132,5	-	-	-	121,0
74	29,2	109,0	129,5	-	-	-	119,0
78	25,7	103,0	128,0	-	-	-	116,0
82	-	-	124,5	-	-	-	110,0
86	-	-	117,5	102,5	-	-	101,0
90	-	-	111,0	97,0	-	-	93,0
94	-	-	105,0	91,7	-	-	85,0
98	-	-	-	86,8	-	-	78,0
102	-	-	-	82,3	-	-	71,5
106	-	-	-	78,2	-	-	65,5
110	-	-	-	74,5	60,8	-	59,5
114	-	-	-	-	57,3	-	54,0
118	-	-	-	-	54,1	-	47,4
122	-	-	-	-	51,1	-	41,2
126	-	-	-	-	-	-	35,1
130	-	-	-	-	-	30,5	29,2
134	-	-	-	-	-	29,0	26,1
138	-	-	-	-	-	-	21,0
142	-	-	-	-	-	-	15,6
146	-	-	-	-	-	-	10,2

m	SWSL						SFSL
	0 t		80 t-450 t				
	85°	85°	75°	65°	55°	45°	t
28	-	108,5*	-	-	-	-	-
30	-	108,5*	-	-	-	-	-
34	86,0	109,5	-	-	-	-	-
38	76,0	109,0	-	-	-	-	106,0
42	67,7	108,0	-	-	-	-	106,0
46	60,5	106,5	-	-	-	-	106,0
50	54,3	105,0	-	-	-	-	106,0
54	48,9	102,5	-	-	-	-	106,0
58	44,1	100,5	-	-	-	-	106,0
62	39,9	98,7	-	-	-	-	106,0
66	35,1	96,5	105,5	-	-	-	106,0
70	30,8	94,4	105,0	-	-	-	102,0
74	27,0	92,3	105,0	-	-	-	99,5
78	23,6	90,2	104,0	-	-	-	96,5
82	20,6	88,1	103,5	-	-	-	94,5
86	17,8	86,0	102,0	-	-	-	93,0
90	15,2	80,4	101,0	-	-	-	91,0
94	-	-	100,0	88,3	-	-	87,0
98	-	-	97,5	83,5	-	-	79,5
102	-	-	92,5	79,0	-	-	73,0
106	-	-	85,7	74,9	-	-	67,0
110	-	-	-	71,1	-	-	61,0
114	-	-	-	67,6	-	-	55,5
118	-	-	-	64,4	50,6	-	50,5
122	-	-	-	61,3	47,6	-	45,5
126	-	-	-	-	44,8	-	39,7
130	-	-	-	-	42,2	-	34,2
134	-	-	-	-	39,8	-	28,8
138	-	-	-	-	-	24,4	24,2
142	-	-	-	-	-	22,6	20,9
146	-	-	-	-	-	20,9	16,4
150	-	-	-	-	-	-	11,7
154	-	-	-	-	-	-	6,9

3

**Remarks · Bemerkungen · Remarques**

Main boom angle 87°, 85°, 75°, 65°, 55° and 45°; capacities for intermediate boom positions are calculated by the crane control system IC-1  
 Hauptauslegerwinkel 87°, 85°, 75°, 65°, 55° und 45°; Traglasten für Zwischenstellungen des Hauptauslegers werden von der Kransteuerung IC-1 berechnet  
 Jarret de flèche principale 87°, 85°, 75°, 65°, 55° et 45°; le système de commande de la grue IC-1 calcule les charges pour les positions intermédiaires de la flèche

\* Main boom angle 87° · Hauptauslegerwinkel 87° · Jarret de flèche principale 87°

# SWSL / SFSL15° LIFTING CAPACITIES · TRAGFÄHIGKEITEN · CAPACITÉS DE LEVAGE

170-250 t 0-80 t ZB 15-24 m 9,60 m 360° ISO

90 m + 96 m

m	SWSL						SFSL
	0 t		80 t-450 t				
	85°	85°	75°	65°	55°	45°	t
32	-	83,2*	-	-	-	-	-
34	-	82,9*	-	-	-	-	-
38	70,1	83,1	-	-	-	-	-
42	62,1	82,6	-	-	-	-	80,5
46	55,2	81,7	-	-	-	-	80,5
50	49,3	80,6	-	-	-	-	80,5
54	44,1	79,3	-	-	-	-	80,5
58	39,5	77,8	-	-	-	-	80,5
62	35,4	76,3	-	-	-	-	80,0
66	31,7	74,7	-	-	-	-	79,5
70	28,4	73,2	77,1	-	-	-	79,5
74	24,6	71,7	77,1	-	-	-	78,0
78	21,2	70,1	77,1	-	-	-	76,0
82	18,1	68,6	77,1	-	-	-	73,5
86	15,4	67,1	76,4	-	-	-	72,5
90	12,9	65,6	76,0	-	-	-	71,0
94	10,5	64,1	75,6	-	-	-	70,0
98	8,4	62,6	74,4	66,6	-	-	68,5
102	6,5	61,1	73,8	66,2	-	-	67,0
106	-	-	73,1	66,2	-	-	66,0
110	-	-	71,5	66,2	-	-	62,0
114	-	-	70,7	64,3	-	-	56,5
118	-	-	67,4	61,1	-	-	51,5
122	-	-	-	58,0	-	-	47,2
126	-	-	-	55,2	41,2	-	42,8
130	-	-	-	52,5	38,7	-	37,6
134	-	-	-	50,0	36,3	-	32,4
138	-	-	-	-	34,0	-	27,5
142	-	-	-	-	31,8	-	22,7
146	-	-	-	-	29,8	-	18,6
150	-	-	-	-	-	15,6	15,1
154	-	-	-	-	-	14,1	11,7
158	-	-	-	-	-	12,7	7,5
162	-	-	-	-	-	-	-
166	-	-	-	-	-	-	-
170	-	-	-	-	-	-	-
174	-	-	-	-	-	-	-

90 m + 108 m

m	SWSL						SFSL
	0 t		80 t-450 t				
	85°	85°	75°	65°	55°	45°	t
34	-	63,7*	-	-	-	-	-
38	-	63,2*	-	-	-	-	-
40	59,0	63,3	-	-	-	-	-
42	56,7	63,3	-	-	-	-	-
46	50,1	62,8	-	-	-	-	61,5
50	44,4	62,1	-	-	-	-	61,5
54	39,4	61,3	-	-	-	-	61,5
58	35,0	60,4	-	-	-	-	61,0
62	31,0	59,4	-	-	-	-	61,0
66	27,5	58,3	-	-	-	-	60,5
70	24,3	57,3	-	-	-	-	60,0
74	21,4	56,2	56,9	-	-	-	59,5
78	18,8	55,1	56,9	-	-	-	59,0
82	15,9	54,1	56,9	-	-	-	57,5
86	13,1	53,0	56,9	-	-	-	56,0
90	10,6	52,0	56,9	-	-	-	55,0
94	8,3	50,9	56,8	-	-	-	54,0
98	6,2	49,8	56,8	-	-	-	53,0
102	-	48,8	56,3	-	-	-	52,5
106	-	47,7	56,3	47,9	-	-	51,5
110	-	46,7	56,1	47,9	-	-	50,5
114	-	45,6	55,6	47,9	-	-	50,0
118	-	-	54,9	47,9	-	-	49,2
122	-	-	54,6	47,6	-	-	48,0
126	-	-	54,3	47,6	-	-	43,5
130	-	-	52,9	47,6	-	-	39,4
134	-	-	-	46,9	32,9	-	35,1
138	-	-	-	44,6	30,7	-	30,4
142	-	-	-	42,4	28,5	-	25,8
146	-	-	-	-	26,5	-	21,3
150	-	-	-	-	24,6	-	17,1
154	-	-	-	-	22,8	-	12,9
158	-	-	-	-	21,1	9,1	9,8
162	-	-	-	-	-	7,8	6,7
166	-	-	-	-	-	6,6	-
170	-	-	-	-	-	5,4	-
174	-	-	-	-	-	-	-

## Remarks · Bemerkungen · Remarques

Main boom angle 87°, 85°, 75°, 65°, 55° and 45°; capacities for intermediate boom positions are calculated by the crane control system IC-1  
 Hauptauslegerwinkel 87°, 85°, 75°, 65°, 55° und 45°; Traglasten für Zwischenstellungen des Hauptauslegers werden von der Kransteuerung IC-1 berechnet  
 Jarret de flèche principale 87°, 85°, 75°, 65°, 55° et 45°; le système de commande de la grue IC-1 calcule les charges pour les positions intermédiaires de la flèche

\* Main boom angle 87° · Hauptauslegerwinkel 87° · Jarret de flèche principale 87°



**SWSL / SFSL15<sup>0</sup> LIFTING CAPACITIES · TRAGFÄHIGKEITEN · CAPACITÉS DE LEVAGE**

m	SWSL						SFSL
	0 t		80 t-450 t				
	85°	85°	75°	65°	55°	45°	
t	t	t	t	t	t	t	
18	-	234,0*	-	-	-	-	-
20	-	232,0*	-	-	-	-	-
22	165,5	238,0	-	-	-	-	230,0
24	153,5	238,0	-	-	-	-	230,0
26	142,5	234,0	-	-	-	-	230,0
28	133,0	230,0	-	-	-	-	230,0
30	125,0	226,0	-	-	-	-	230,0
34	110,5	217,0	-	-	-	-	230,0
38	99,0	209,0	-	-	-	-	230,0
42	86,4	202,0	-	-	-	-	227,0
46	75,3	195,0	230,0	-	-	-	221,0
50	-	-	226,0	-	-	-	211,0
54	-	-	212,0	-	-	-	198,0
58	-	-	195,0	-	-	-	178,0
62	-	-	180,0	-	-	-	161,0
66	-	-	-	147,5	-	-	146,0
70	-	-	-	138,0	-	-	132,0
74	-	-	-	129,5	-	-	120,0
78	-	-	-	122,0	-	-	109,0
82	-	-	-	-	-	-	99,5
86	-	-	-	-	92,7	-	90,5
90	-	-	-	-	87,8	-	82,0
94	-	-	-	-	-	-	74,5
98	-	-	-	-	-	-	65,5
102	-	-	-	-	-	56,8	56,5
106	-	-	-	-	-	53,5	48,2
110	-	-	-	-	-	-	40,2
114	-	-	-	-	-	-	36,1
118	-	-	-	-	-	-	28,4
122	-	-	-	-	-	-	-
126	-	-	-	-	-	-	-

m	SWSL						SFSL
	0 t		80 t-450 t				
	85°	85°	75°	65°	55°	45°	
t	t	t	t	t	t	t	
20	-	190,0*	-	-	-	-	-
22	-	190,0*	-	-	-	-	-
24	-	187,5*	-	-	-	-	-
26	133,0	193,0	-	-	-	-	186,0
28	124,0	192,0	-	-	-	-	186,0
30	116,5	190,0	-	-	-	-	186,0
34	103,0	184,5	-	-	-	-	186,0
38	92,0	178,0	-	-	-	-	186,0
42	82,8	172,0	-	-	-	-	186,0
46	73,0	166,0	-	-	-	-	183,0
50	64,1	161,0	189,0	-	-	-	181,0
54	56,5	155,5	187,5	-	-	-	176,0
58	-	-	182,0	-	-	-	169,0
62	-	-	177,5	-	-	-	164,0
66	-	-	165,0	-	-	-	149,0
70	-	-	153,5	-	-	-	135,0
74	-	-	143,5	125,0	-	-	123,0
78	-	-	-	117,0	-	-	112,0
82	-	-	-	110,5	-	-	102,0
86	-	-	-	104,0	-	-	93,0
90	-	-	-	98,9	-	-	84,5
94	-	-	-	-	78,3	-	77,0
98	-	-	-	-	74,2	-	70,0
102	-	-	-	-	70,6	-	63,0
106	-	-	-	-	-	-	55,5
110	-	-	-	-	-	-	47,9
114	-	-	-	-	-	-	40,7
118	-	-	-	-	-	-	33,8
122	-	-	-	-	-	-	30,3
126	-	-	-	-	-	-	23,8
130	-	-	-	-	-	-	17,3

**3**
**Remarks · Bemerkungen · Remarques**

Main boom angle 87°, 85°, 75°, 65°, 55° and 45°; capacities for intermediate boom positions are calculated by the crane control system IC-1  
 Hauptauslegerwinkel 87°, 85°, 75°, 65°, 55° und 45°; Traglasten für Zwischenstellungen des Hauptauslegers werden von der Kransteuerung IC-1 berechnet  
 Jarret de flèche principale 87°, 85°, 75°, 65°, 55° et 45°; le système de commande de la grue IC-1 calcule les charges pour les positions intermédiaires de la flèche

\* Main boom angle 87° · Hauptauslegerwinkel 87° · Jarret de flèche principale 87°

# SWSL / SFSL15° LIFTING CAPACITIES · TRAGFÄHIGKEITEN · CAPACITÉS DE LEVAGE

170-250 t 0-80 t ZB 15-24 m 9,60 m 360° ISO

96 m + 60 m

m	SWSL						SFSL
	0 t		80 t-450 t				
	85°	85°	75°	65°	55°	45°	t
24	-	154,5*	-	-	-	-	-
26	-	153,0*	-	-	-	-	-
28	-	151,5*	-	-	-	-	-
30	108,0	156,5	-	-	-	-	150,0
34	95,6	153,5	-	-	-	-	150,0
38	85,1	150,0	-	-	-	-	150,0
42	76,3	145,5	-	-	-	-	150,0
46	68,9	141,5	-	-	-	-	150,0
50	62,4	137,0	-	-	-	-	150,0
54	56,8	133,0	-	-	-	-	148,0
58	50,5	129,0	152,5	-	-	-	146,0
62	44,8	125,5	150,5	-	-	-	140,0
66	39,8	121,5	148,0	-	-	-	136,0
70	-	-	143,5	-	-	-	132,0
74	-	-	140,5	-	-	-	127,0
78	-	-	135,0	-	-	-	116,0
82	-	-	127,0	108,5	-	-	106,0
86	-	-	-	102,0	-	-	97,0
90	-	-	-	96,8	-	-	89,0
94	-	-	-	91,6	-	-	81,0
98	-	-	-	86,9	-	-	74,0
102	-	-	-	-	68,0	-	67,5
106	-	-	-	-	64,5	-	61,5
110	-	-	-	-	61,3	-	55,5
114	-	-	-	-	58,0	-	48,9
118	-	-	-	-	-	-	42,2
122	-	-	-	-	-	35,1	35,8
126	-	-	-	-	-	32,9	29,5
130	-	-	-	-	-	-	26,3
134	-	-	-	-	-	-	20,7
138	-	-	-	-	-	-	14,9
142	-	-	-	-	-	-	9,1
146	-	-	-	-	-	-	-

96 m + 72 m

m	SWSL						SFSL
	0 t		80 t-450 t				
	85°	85°	75°	65°	55°	45°	t
26	-	124,5*	-	-	-	-	-
28	-	123,5*	-	-	-	-	-
30	-	122,5*	-	-	-	-	-
32	93,3	125,5	-	-	-	-	-
34	87,5	125,0	-	-	-	-	121,0
38	77,6	123,5	-	-	-	-	121,0
42	69,3	121,0	-	-	-	-	121,0
46	62,1	118,5	-	-	-	-	121,0
50	55,9	115,0	-	-	-	-	121,0
54	50,5	112,0	-	-	-	-	121,0
58	45,8	109,0	-	-	-	-	121,0
62	40,7	106,0	121,0	-	-	-	119,0
66	35,9	103,5	121,0	-	-	-	116,0
70	31,7	100,5	119,5	-	-	-	111,0
74	27,9	97,9	118,0	-	-	-	108,0
78	24,5	95,2	115,5	-	-	-	105,0
82	-	-	112,5	-	-	-	103,0
86	-	-	110,5	-	-	-	98,5
90	-	-	108,5	92,3	-	-	90,0
94	-	-	102,5	87,2	-	-	82,5
98	-	-	-	82,5	-	-	75,0
102	-	-	-	78,2	-	-	68,5
106	-	-	-	74,2	-	-	62,5
110	-	-	-	70,6	-	-	56,5
114	-	-	-	-	52,6	-	51,5
118	-	-	-	-	49,5	-	45,6
122	-	-	-	-	46,6	-	39,6
126	-	-	-	-	43,9	-	33,7
130	-	-	-	-	-	-	28,1
134	-	-	-	-	-	24,5	23,6
138	-	-	-	-	-	22,7	19,5
142	-	-	-	-	-	-	14,9
146	-	-	-	-	-	-	9,9

## Remarks · Bemerkungen · Remarques

Main boom angle 87°, 85°, 75°, 65°, 55° and 45°; capacities for intermediate boom positions are calculated by the crane control system IC-1

Hauptauslegerwinkel 87°, 85°, 75°, 65°, 55° und 45°; Traglasten für Zwischenstellungen des Hauptauslegers werden von der Kransteuerung IC-1 berechnet

Jarret de flèche principale 87°, 85°, 75°, 65°, 55° et 45°; le système de commande de la grue IC-1 calcule les charges pour les positions intermédiaires de la flèche

\* Main boom angle 87° · Hauptauslegerwinkel 87° · Jarret de flèche principale 87°

# SWSL / SFSL15° LIFTING CAPACITIES · TRAGFÄHIGKEITEN · CAPACITÉS DE LEVAGE

170-250 t 0-80 t ZB 15-24 m 9,60 m 360° ISO

96 m + 84 m

96 m + 96 m

m	SWSL						SFSL	
	0 t		80 t-450 t					
	85°	85°	75°	65°	55°	45°	t	t
30	-	99,9*	-	-	-	-	-	-
34	-	98,4*	-	-	-	-	-	-
36	76,3	100,5	-	-	-	-	-	-
38	71,7	100,5	-	-	-	-	97,0	-
42	63,8	99,2	-	-	-	-	97,0	-
46	57,0	97,7	-	-	-	-	97,0	-
50	51,0	95,9	-	-	-	-	97,0	-
54	45,9	93,9	-	-	-	-	97,0	-
58	41,3	91,7	-	-	-	-	97,0	-
62	37,3	89,6	-	-	-	-	97,0	-
66	33,6	87,4	96,5	-	-	-	97,0	-
70	29,5	85,4	96,5	-	-	-	96,0	-
74	25,8	83,3	95,9	-	-	-	92,0	-
78	22,4	81,3	95,7	-	-	-	89,5	-
82	19,4	79,2	94,0	-	-	-	87,0	-
86	16,7	77,2	93,1	-	-	-	85,5	-
90	14,2	75,1	92,2	-	-	-	83,5	-
94	-	-	89,6	82,7	-	-	82,0	-
98	-	-	88,1	79,1	-	-	77,0	-
102	-	-	86,6	74,8	-	-	70,0	-
106	-	-	85,1	70,9	-	-	64,0	-
110	-	-	-	67,2	-	-	58,0	-
114	-	-	-	63,8	-	-	53,0	-
118	-	-	-	60,7	-	-	48,0	-
122	-	-	-	57,8	43,0	-	43,3	-
126	-	-	-	-	40,4	-	37,8	-
130	-	-	-	-	37,9	-	32,4	-
134	-	-	-	-	35,6	-	27,2	-
138	-	-	-	-	33,4	-	22,2	-
142	-	-	-	-	-	17,2	17,7	-
146	-	-	-	-	-	15,7	14,0	-
150	-	-	-	-	-	14,3	10,5	-
154	-	-	-	-	-	-	6,1	-
158	-	-	-	-	-	-	-	-
162	-	-	-	-	-	-	-	-

m	SWSL						SFSL	
	0 t		80 t-450 t					
	85°	85°	75°	65°	55°	45°	t	t
32	-	77,7*	-	-	-	-	-	-
34	-	77,4*	-	-	-	-	-	-
38	65,9	77,6	-	-	-	-	-	-
42	58,3	77,2	-	-	-	-	75,0	-
46	51,7	76,4	-	-	-	-	75,0	-
50	46,1	75,4	-	-	-	-	75,0	-
54	41,1	74,2	-	-	-	-	75,0	-
58	36,7	72,8	-	-	-	-	75,0	-
62	32,8	71,3	-	-	-	-	75,0	-
66	29,2	69,9	-	-	-	-	74,5	-
70	26,1	68,4	72,1	-	-	-	74,5	-
74	23,2	66,9	72,1	-	-	-	74,0	-
78	20,0	65,5	72,1	-	-	-	71,5	-
82	17,0	64,1	72,1	-	-	-	69,5	-
86	14,3	62,7	71,6	-	-	-	67,5	-
90	11,8	61,3	71,2	-	-	-	66,0	-
94	9,5	59,9	70,9	-	-	-	64,5	-
98	7,5	58,4	70,0	-	-	-	63,5	-
102	5,5	57,0	69,2	61,5	-	-	62,0	-
106	-	-	68,4	61,5	-	-	60,5	-
110	-	-	67,6	61,5	-	-	59,5	-
114	-	-	65,8	60,5	-	-	54,0	-
118	-	-	65,0	57,4	-	-	49,1	-
122	-	-	-	54,5	-	-	44,4	-
126	-	-	-	51,7	-	-	40,0	-
130	-	-	-	49,1	34,3	-	35,4	-
134	-	-	-	46,7	32,0	-	30,4	-
138	-	-	-	-	29,9	-	25,6	-
142	-	-	-	-	27,9	-	21,0	-
146	-	-	-	-	25,9	-	16,5	-
150	-	-	-	-	24,1	-	12,2	-
154	-	-	-	-	-	9,1	8,7	-
158	-	-	-	-	-	7,8	5,5	-
162	-	-	-	-	-	6,6	-	-
166	-	-	-	-	-	-	-	-

3

### Remarks · Bemerkungen · Remarques

Main boom angle 87°, 85°, 75°, 65°, 55° and 45°; capacities for intermediate boom positions are calculated by the crane control system IC-1  
 Hauptauslegerwinkel 87°, 85°, 75°, 65°, 55° und 45°; Traglasten für Zwischenstellungen des Hauptauslegers werden von der Kransteuerung IC-1 berechnet  
 Jarret de flèche principale 87°, 85°, 75°, 65°, 55° et 45°; le système de commande de la grue IC-1 calcule les charges pour les positions intermédiaires de la flèche

\* Main boom angle 87° · Hauptauslegerwinkel 87° · Jarret de flèche principale 87°

# SWSL / SFSL15<sup>0</sup> LIFTING CAPACITIES · TRAGFÄHIGKEITEN · CAPACITÉS DE LEVAGE

170-250 t 0-80 t ZB 15-24 m 9,60 m 360° ISO

96 m + 108 m

m	SWSL						SFSL
	0 t		80 t-450 t				
	85°	85°	75°	65°	55°	45°	t
34	-	59,4*	-	-	-	-	-
38	-	58,9*	-	-	-	-	-
42	52,9	58,9	-	-	-	-	-
46	46,7	58,6	-	-	-	-	57,0
50	41,2	57,9	-	-	-	-	57,0
54	36,4	57,1	-	-	-	-	57,0
58	32,2	56,3	-	-	-	-	57,0
62	28,4	55,4	-	-	-	-	57,0
66	25,0	54,4	-	-	-	-	56,5
70	21,9	53,4	-	-	-	-	56,0
74	19,2	52,3	-	-	-	-	55,5
78	16,7	51,3	53,1	-	-	-	55,0
82	14,3	50,3	53,1	-	-	-	54,0
86	12,0	49,3	53,1	-	-	-	52,5
90	9,6	48,2	53,1	-	-	-	51,0
94	7,3	47,2	53,0	-	-	-	50,5
98	5,2	46,2	53,0	-	-	-	49,6
102	-	45,2	52,6	-	-	-	48,8
106	-	44,1	52,5	-	-	-	48,0
110	-	43,1	52,4	44,5	-	-	47,2
114	-	42,1	52,2	44,5	-	-	46,4
118	-	-	51,3	44,5	-	-	45,6
122	-	-	51,0	44,1	-	-	44,7
126	-	-	50,8	44,1	-	-	40,9
130	-	-	50,5	44,1	-	-	36,7
134	-	-	-	43,7	-	-	32,9
138	-	-	-	41,4	26,5	-	28,2
142	-	-	-	39,1	24,5	-	23,7
146	-	-	-	36,8	22,6	-	19,4
150	-	-	-	-	20,8	-	15,2
154	-	-	-	-	19,1	-	11,2
158	-	-	-	-	17,5	-	7,2
162	-	-	-	-	15,9	-	-

## Remarks · Bemerkungen · Remarques

Main boom angle 87°, 85°, 75°, 65°, 55° and 45°; capacities for intermediate boom positions are calculated by the crane control system IC-1  
 Hauptauslegerwinkel 87°, 85°, 75°, 65°, 55° und 45°; Traglasten für Zwischenstellungen des Hauptauslegers werden von der Kransteuerung IC-1 berechnet  
 Jarret de flèche principale 87°, 85°, 75°, 65°, 55° et 45°; le système de commande de la grue IC-1 calcule les charges pour les positions intermédiaires de la flèche

\* Main boom angle 87° · Hauptauslegerwinkel 87° · Jarret de flèche principale 87°

**NOTES TO LIFTING CAPACITY · ANMERKUNGEN ZU DEN TRAGFÄHIGKEITEN ·  
CONDITIONS D'UTILISATION**

Ratings are in compliance with ISO 4305.

Weight of hook blocks and slings is part of the load, and is to be deducted from the capacity ratings.

Consult operation manual for further details.

**Note:** Data published herein is intended as a guide only and shall not be construed to warrant applicability for lifting purposes.

Crane operation is subject to the computer charts and operation manual both supplied with the crane.

In some instances the superlift counterweight does not lift off the ground with the indicated load.

Tragfähigkeiten entsprechen ISO 4305.

Das Gewicht der Unterflaschen, sowie die Lastaufnahmemittel, sind Bestandteile der Last und sind von den Tragfähigkeitsangaben abzuziehen.

Weitere Angaben in der Bedienungsanleitung des Kranes.

**Anmerkung:** Die Daten dieser Broschüre dienen nur zur allgemeinen Information; für ihre Richtigkeit übernehmen wir keine Haftung.

Der Betrieb des Kranes ist nur mit den Original-Tragfähigkeitstabellen und mit der Bedienungsanleitung zulässig, die mit dem Kran mitgeliefert werden.

In einigen Fällen hebt das Superliftgegengewicht bei den angegebenen Traglasten nicht ab.

Le tableau de charges est conforme à la norme ISO 4305.

Les poids du crochet-moufle et de tous les accessoires d'élingage font partie de la charge et sont à déduire des charges indiquées.

Pour plus de détails consulter la notice d'utilisation de la grue.

**Nota:** Les renseignements ci-inclus sont donnés à titre indicatif et ne représentent aucune garantie d'utilisation pour les opérations de levage.

La mise en service de la grue n'est autorisée qu'à condition que les tableaux de charges ainsi que le manuel de service, tels que fournis avec la grue, soient observés.

Le contrepoids du superlift ne décolle pas dans certaines configurations des tableaux de charge.

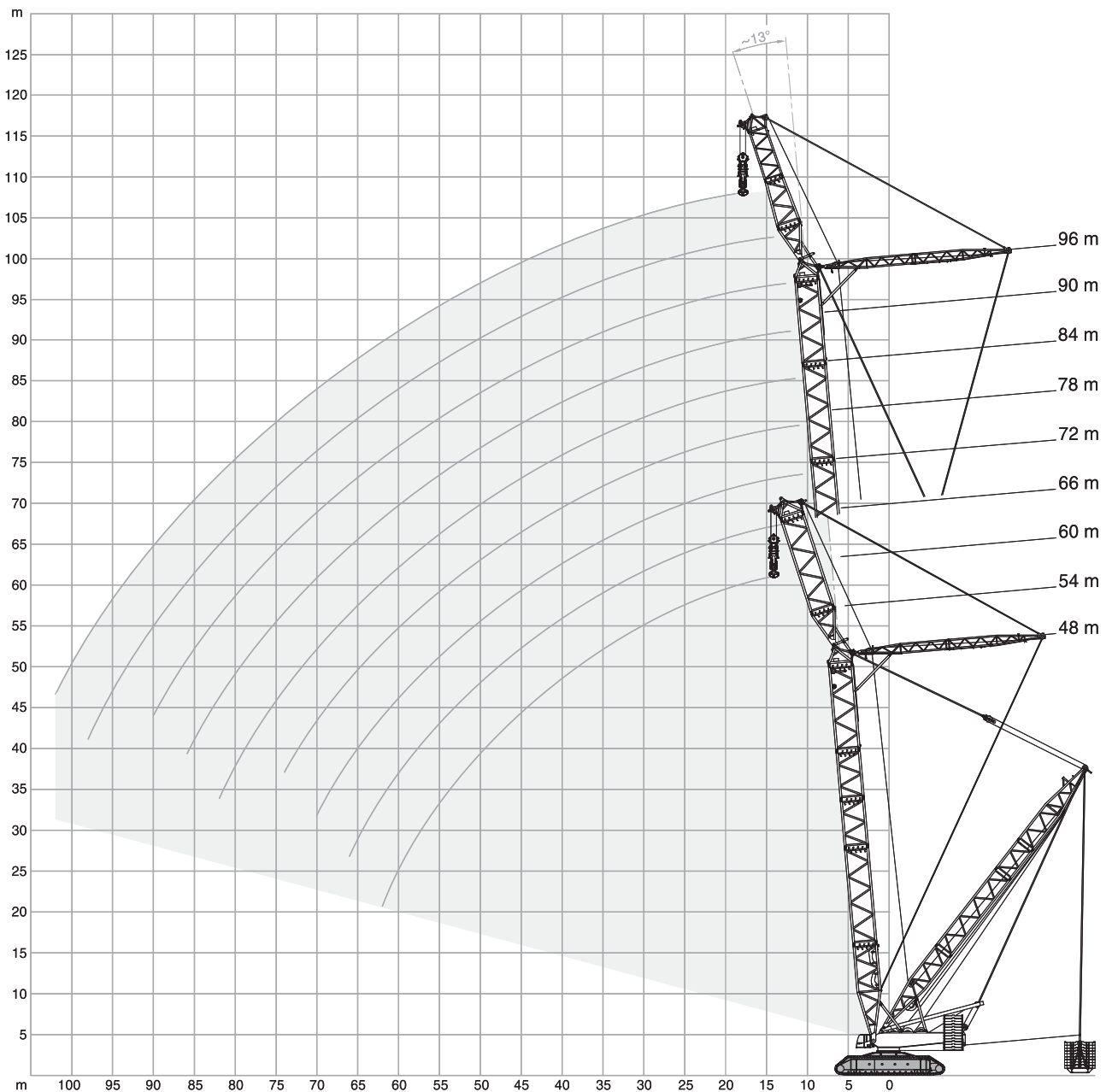

**SFVL / LFVL LIFTING CAPACITIES · TRAGFÄHIGKEITEN · CAPACITÉS DE LEVAGE**

170-250 t 0-80 t ZB 15-24 m 18 m 13° 9,60 m 360° ISO

m	48 m		54 m		60 m		66 m		72 m		78 m		84 m		90 m		96 m	
	LFVL	SFVL	LFVL	SFVL	LFVL	SFVL	LFVL	SFVL	LFVL	SFVL	LFVL	SFVL	LFVL	SFVL	LFVL	SFVL	LFVL	SFVL
14	506,0	-	-	-	-	-	-	-	-	-	-	-	-	-	-	-	-	-
15	506,0	752,0	506,0	679,0	506,0	-	-	-	-	-	-	-	-	-	-	-	-	-
16	506,0	743,0	506,0	679,0	506,0	620,0	506,0	561,0	506,0	-	-	-	-	-	-	-	-	-
17	506,0	726,0	506,0	671,0	506,0	612,0	506,0	561,0	506,0	504,0	458,0	412,0	-	-	-	-	-	-
18	506,0	702,0	506,0	671,0	506,0	612,0	506,0	561,0	506,0	504,0	458,0	412,0	371,0	-	-	-	-	-
19	506,0	679,0	506,0	661,0	506,0	603,0	506,0	552,0	506,0	504,0	458,0	412,0	371,0	333,0	-	-	-	-
20	506,0	658,0	506,0	643,0	506,0	603,0	506,0	552,0	506,0	497,0	458,0	412,0	371,0	333,0	-	-	-	-
22	506,0	609,0	506,0	605,0	506,0	595,0	506,0	543,0	506,0	495,0	458,0	412,0	371,0	333,0	-	-	-	-
24	506,0	554,0	506,0	550,0	506,0	546,0	506,0	535,0	495,0	488,0	451,0	411,0	371,0	333,0	-	-	-	-
26	501,0	507,0	504,0	503,0	501,0	499,0	506,0	495,0	487,0	480,0	444,0	405,0	371,0	333,0	-	-	-	-
28	480,0	467,0	476,0	463,0	473,0	459,0	470,0	455,0	466,0	451,0	439,0	399,0	365,0	333,0	-	-	-	-
30	444,0	432,0	441,0	428,0	437,0	423,0	434,0	420,0	431,0	415,0	427,0	395,0	360,0	328,0	-	-	-	-
34	387,0	374,0	383,0	370,0	379,0	365,0	376,0	362,0	373,0	357,0	369,0	366,0	356,0	325,0	-	-	-	-
38	341,0	328,0	337,0	324,0	333,0	320,0	330,0	316,0	326,0	311,0	323,0	319,0	316,0	312,0	-	-	-	-
42	295,0	281,0	300,0	287,0	296,0	282,0	293,0	279,0	289,0	274,0	286,0	282,0	279,0	275,0	-	-	-	-
46	253,0	240,0	269,0	256,0	265,0	252,0	262,0	248,0	258,0	243,0	255,0	251,0	247,0	244,0	-	-	-	-
50	220,0	211,0	235,0	221,0	239,0	226,0	236,0	222,0	232,0	217,0	229,0	225,0	221,0	218,0	-	-	-	-
54	194,0	182,0	204,0	190,0	216,0	201,0	213,0	200,0	210,0	195,0	206,0	202,0	199,0	195,0	-	-	-	-
58	165,0	154,0	178,0	169,0	188,0	174,0	193,0	180,0	190,0	177,0	187,0	183,0	180,0	176,0	-	-	-	-
62	146,0	135,0	158,0	146,0	164,0	150,0	171,0	157,0	173,0	160,0	170,0	167,0	163,0	159,0	-	-	-	-
66	-	-	134,0	123,0	146,0	136,0	150,0	136,0	156,0	141,0	156,0	152,0	148,0	144,0	-	-	-	-
70	-	-	-	-	127,0	115,0	132,0	122,0	137,0	122,0	141,0	139,0	135,0	131,0	-	-	-	-
74	-	-	-	-	-	-	118,0	106,0	119,0	107,0	125,0	127,0	124,0	120,0	-	-	-	-
78	-	-	-	-	-	-	-	-	108,0	96,5	109,0	112,0	113,0	110,0	-	-	-	-
82	-	-	-	-	-	-	-	-	93,5	81,0	97,5	98,5	100,0	100,0	-	-	-	-
86	-	-	-	-	-	-	-	-	-	-	86,5	86,5	88,0	88,5	-	-	-	-
90	-	-	-	-	-	-	-	-	-	-	-	78,0	76,0	77,0	-	-	-	-
94	-	-	-	-	-	-	-	-	-	-	-	-	69,5	66,5	-	-	-	-
98	-	-	-	-	-	-	-	-	-	-	-	-	59,0	59,5	-	-	-	-
102	-	-	-	-	-	-	-	-	-	-	-	-	-	51,0	-	-	-	-
106	-	-	-	-	-	-	-	-	-	-	-	-	-	-	-	-	-	-

## TECHNICAL DESCRIPTION

### CRAWLER CARRIER

	3-section carrier comprising of carbody with folded outriggers for the transport and two crawlers. Hydraulic pin connections between crawlers and carbody provide for easy assembly and removal to minimise width and weight for transportation.
<b>Center pot</b>	Bending- and torsion-resistant welded structure fabricated from high-strength fine grain structural steel.
<b>Crawler side frames</b>	Bending-resistant welded structure fabricated from high-strength fine grain structural steel. Centralized lubrication included as standard.
<b>Crawlers</b>	15 track rollers with hardened rolling surfaces. Raised position for both drive sprockets and idler wheels, drive sprockets and idler wheels provide load bearing capacity for erection, adjustable track tension. Each crawler is infinitely variable controlled, both independently and in opposite direction.
<b>Power train</b>	The tracks are powered by two hydraulic motors each through closed planetary gear reduction units running in oil bath, equipped with spring-applied hydraulically released holding brakes. The gear units are of extremely compact design to fit within the width of the crawlers. Each crawler is infinitely variable controlled, both independently and in opposite direction. Quadro-Drive as standard.
<b>Central ballast</b>	80 t.

### SUPERSTRUCTURE

<b>Counterweight</b>	250 t.
<b>Frame</b>	Bending- and torsion-resistant welded structure fabricated from high-strength fine grain structural steel.
<b>Drive</b>	Two redundant operating water-cooled 6-cylinder DaimlerChrysler diesel engine type OM 460 LA, 2 x 315 kW (428 HP) at 1800 1/min. The engine complies with EUROMOT 3a, EPA T3 and Carb regulations. Fuel tank capacity: 1500 l.
<b>Rope drums</b>	The standard superstructure equipment includes three rope drums – hoist 1, hoist 2 and boom hoist. The drums are powered by hydraulic motors through closed planetary gear units running in oil bath. All rope drums have spring-applied, hydraulically released multi-disk brakes and non-wearing hydraulic braking for load lowering. Rope ends H 1, 2, 3 and W 1, 2 equipped with quick-connect rope end fittings. Hoists H 1 and H 2 and A-frame with boom hoist are removable to minimise weight for transportation.
<b>A-frame</b>	Cylinders on superstructure to raise A-frame are included as standard.
<b>Slew units</b>	Powered by four hydraulic motors through closed, planetary gear unit running in oil bath. Spring-applied, hydraulically released holding brake and non-wearing hydraulic braking.
<b>Control system</b>	Demag IC-1: Electronic proportional valve pilot control integrated in stored-program control system incl. diagnostics. Two colour monitors, load indicator operated via a touchscreen. Working speeds infinitely variable controlled by the lever position. Automatic power control for optimal utilisation of engine output. Standard working range limitation, ground pressure indicator as well as outrigger loading indicator.
<b>Cabin</b>	Comfortable cab with large windscreen and air-conditioning. Laminated glass all around, roof window, self-contained hot air heater, full instrumentation and crane controls. The cab can be tilted back for improved operator view of boom point. A camera system is installed to monitor the rope drums. For transportation, the cab swings in front of the superstructure to minimise width.
<b>Electrical equipment</b>	24 V system (2 batteries 12 V / 180 Ah).
<b>Quick-connection</b>	Hydraulic quick-disconnect fittings on carrier and superstructure facilitate removal to minimise weight for transportation as standard.

### OPTIONAL EQUIPMENT

<b>Hydraulic cylinder A-frame</b>	For self-assembly of crawlers.
<b>Sideways outriggers</b>	For erection of long boom systems.
<b>Counterweight carrier</b>	Total weight max. 450 t, in combination with SL telescopic system.
<b>PC outriggers</b>	Outrigger base 14 x14 m. Alternatively to the crawlers.

Further options on request!



**TECHNICAL DESCRIPTION**
**BOOM CONFIGURATIONS S AND L**

<b>SH:</b>	Main boom: foot section 12 m, inserts 6 m, 10.5 m and 12 m (type 3328), boom head 1.5 m. Main boom lengths: 36-96 m.
<b>SH / LH: (SGL variable)</b>	Main boom: foot section 12 m, inserts 6 m, 10.5 m and 12 m (type 3328), tapered insert, extended by inserts 6 m and 12 m (type 2822), top section 7.5 m. Main boom lengths: 48-108 m.
<b>LH:</b>	Main boom: foot section 12 m, insert 10.5 m (type 3328), tapered insert, extended by inserts 6 m and 12 m (type 2822), jib top section 7.5 m. Main boom lengths: 48-114 m.
<b>SW:</b>	Main boom: same as SH. Offset 87° to 65°. Luffing fly jib: foot section 4.5 m, insert 12 m (type 3328), tapered insert, insert 6 m and inserts 12 m (type 2822), jib top section 7.5 m. Main boom lengths: 42-60 m. Fly jib lengths: 30-96 m.
<b>SSL:</b>	Main boom: same as SH. Superlift equipment. Main boom lengths: 42-96 m.
<b>SSL / LSL: (SGL 94.5 m)</b>	Main boom: foot section 12 m, inserts 6 m, 10.5 m and 12 m (type 2822), tapered insert, extended by inserts 6 m and 12 m (type 2822), top section 7.5 m. Superlift equipment. Main boom lengths: 102-150 m.
<b>SWSL / SFSL:</b>	Main boom: same as SH. Offset 87° to 45°. Luffing fly jib: same as SW. Superlift equipment. Main boom lengths: 48-96 m. Fly jib lengths: 30-108 m.
<b>SFVL:</b>	Main boom: same as SH. Superlift equipment. Fixed jib: foot section 4.5 m, intermediate section 12 m (type 3328), additional SFVL-head included. Main boom lengths: 48-72 m. Fly jib length: 18 m.
<b>LFVL:</b>	Main boom: same as SH. Superlift equipment. Fixed jib: foot section 4.5 m, tapered insert, jib top section 7.5 m. Main boom lengths: 48-96 m. Fly jib length: 18 m.
<b>+ LF:</b>	Addition to SH, SH/LH, SSL or SSL/LSL. Fixed fly jib: foot section 6 m, inserts 12 m (type 1815), jib top section 6 m. Fly jib lengths: 12-36 m. Offset: 10°, 20° and 30°.
<b>Pinning of boom</b>	Hydraulic assisted pinning of boom sections is standard.
<b>Reeving winch</b>	Mounted on superstructure.
<b>Operator aids</b>	Electronic load indicator, hoist limit switch, limit switches for boom movements, hydraulic boom backstops, anemometer.

**OPTIONAL EQUIPMENT**

<b>Standard Superlift equipment</b>	Mast 40.5 m (type 2322), counterweight tray for max. 450 t. Superlift radii 15, 18, 21, 24 m.
<b>Variable Superlift equipment</b>	Mast 40.5 m (type 2322), counterweight tray for max. 450 t. Superlift radius infinitely variable during operation 15 to 24 m. Vertical cylinder and stabilising system for Superlift counterweight.
<b>Superlift with counterweight carrier</b>	Mast 40.5 m (type 2322), counterweight carrier for max. 450 t. Superlift radius infinitely variable during operation 18 to 24 m.
<b>Hoist H3</b>	Additional rope drum on main boom (for LF or runner operation). Line pull same as H1, rope length 700 m.
<b>Runner 46 t</b>	Approx. 2 m for installation on boom head or top section.

## TECHNISCHE BESCHREIBUNG

### RAUPENUNTERWAGEN

<b>Mittelstück</b>	Der Raupenunterwagen ist 3-teilig und besteht aus dem Mittelstück mit für den Transport angeklappten Stützträgern und zwei Raupen. Mittelstück und Raupen werden hydraulisch verbolzt und sind einfach demontierbar zum Erreichen günstiger Transportabmessungen und Gewichte.
<b>Raupenträger</b>	Biege- und verwindungssteife Schweißkonstruktion aus hochfestem Feinkornbaustahl.
<b>Raupen</b>	Biegesteife Schweißkonstruktion aus hochfestem Feinkornbaustahl. Serienmäßig mit Zentral-Schmierung ausgestattet.
<b>Antrieb</b>	15 Laufrollen je Raupenträger mit gehärteten Laufflächen. Jedes Laufwerk wird von Hydromotoren über geschlossene, ölbadgeschmierte Planetengetriebe angetrieben. Jede Seite ist stufenlos einzeln und gegenläufig steuerbar.
<b>Zentralballast</b>	Die Raupen werden von je zwei Hydromotoren über geschlossene, ölbadgeschmierte Planetengetriebe mit federbelasteten, hydraulisch gelüfteten Haltebremsen angetrieben. Die Getriebe sind in besonders kompakter Bauform innerhalb der Raupenbreite angeordnet. Jede Seite ist stufenlos, einzeln und gegenläufig steuerbar. Quadro-Antrieb serienmäßig.
	80 t.

### OBERWAGEN

<b>Gegengewicht</b>	250 t.
<b>Rahmen</b>	Biege- und verwindungssteife Schweißkonstruktion aus hochfestem Feinkornbaustahl.
<b>Antrieb</b>	Zwei redundant arbeitende wassergekühlte 6-Zylinder DaimlerChrysler Dieselmotoren Typ OM 460 LA, 2 x 315 kW (428 PS) bei 1800 1/min. Der Motor erfüllt die EUROMOT 3a, EPA T3 und Carb-Vorschriften. Kraftstoffbehälter: 1500 l.
<b>Seilwinden</b>	Der Oberwagen ist serienmäßig mit drei Seilwinden – Hubwerk 1, Hubwerk 2 und Einziehwerk – ausgerüstet. Der Antrieb der Winden erfolgt durch Hydromotoren über geschlossene, ölbadgeschmierte Planetengetriebe. Alle Seilwinden sind mit federbelasteten, hydraulisch gelüfteten Lamellenbremsen und verschleißfreier, hydraulischer Bremsung für den Senkvorgang ausgerüstet. Die Seilenden H 1, 2, 3 und W 1, 2 sind mit Preßfitting und Taschen ausgestattet. Zur Reduzierung der Transportgewichte sind die Winden H 1 und H 2 sowie der A-Bock mit Einziehwerk ausbaubar.
<b>A-Bock</b>	Hydraulikzylinder im Oberwagen für die Umlage des A-Bockes serienmäßig.
<b>Drehwerk</b>	Vier Drehwerke mit Antrieb durch Hydromotor über geschlossenes, ölbadgeschmiertes Planetengetriebe. Federbelastete, hydraulisch löfbbare Haltebremse und verschleißfreie hydraulische Bremse.
<b>Steuerung</b>	Demag IC-1: Elektronische Proportionalventilvorsteuerung integriert in eine speicherprogrammierte Steuerung mit Fehlerdiagnose. Zwei Farbbildschirme, Bedienung über Touchscreen. Die Arbeitsgeschwindigkeiten werden durch die Hebelstellung stufenlos geregelt. Leistungsregelung der Antriebe zur optimalen Nutzung der Motorleistung. Serienmäßig Arbeitsbereichsbegrenzung und Anzeige der Bodenpressung bzw. Stützkräfte.
<b>Kabine</b>	Komfortkabine mit großem Frontfenster und Klimaanlage. Sicherheitsverglasung rundum, Dachfenster, motorunabhängige Warmluftheizung und Steuer- und Kontrollelemente für die Kranfunktionen. Die Kabine ist zur Sichtverbesserung nach hinten neigbar. Zur Überwachung der Winden im Oberwagen ist ein Kamerasystem installiert. Während des Transportes ist die Kabine vor den Oberwagen geschwenkt.
<b>Elektrische Anlage</b>	Betriebsspannung 24 V (2 Batterien 12 V / 180 Ah).
<b>Quick-connection</b>	Hydraulische Schnellverbindung Unterwagen/Oberwagen zur Reduzierung der Transportgewichte serienmäßig.

### ZUSATZAUSRÜSTUNG

<b>Zylinder am A-Bock</b>	Zur Raupenträger-Selbstmontage.
<b>Zusatzabstützung seitlich</b>	Zum Aufrichten langer Auslegersysteme.
<b>Gegengewichtswagen</b>	Zulässiges Gesamtgewicht 450 t, in Verbindung mit Teleskop-SL-Einrichtung.
<b>PC-Stützen</b>	Stützbasis 14 x 14 m. Zur Verwendung alternativ zu den Raupen.

Weitere Zusatzausrüstungen auf Anfrage!

**TECHNISCHE BESCHREIBUNG**
**AUSLEGERVARIANTEN S UND L**

<b>SH:</b>	Hauptausleger: Fußstück 12 m, Zwischenstücke 6 m, 10,5 m und 12 m (Typ 3328), Anschlusskopf 1,5 m. Hauptauslegerlängen: 36-96 m.
<b>SH / LH:</b> (SGL variabel)	Hauptausleger: Fußstück 12 m, Zwischenstücke 6 m, 10,5 m und 12 m (Typ 3328), Reduzierstück, verlängert um Zwischenstücke 6 m und 12 m (Typ 2822), Spitze 7,5 m. Hauptauslegerlängen: 48-108 m.
<b>LH:</b>	Hauptausleger: Fußstück 12 m, Zwischenstück 10,5 m (Typ 3328), Reduzierstück, verlängert um Zwischenstücke 6 m und 12 m (Typ 2822), Spitze 7,5 m. Hauptauslegerlängen: 48-114 m.
<b>SW:</b>	Hauptausleger: wie SH. Vorneigung 87° bis 65°. Wippbarer Hilfsausleger: Fußstück 4,5 m, Zwischenstück 12 m (Typ 3328), Reduzierstück, Zwischenstück 6 m und Zwischenstücke 12 m (Typ 2822), Spitze 7,5 m. Hauptauslegerlängen: 42-60 m. Hilfsauslegerlängen: 30-96 m.
<b>SSL:</b>	Hauptausleger: wie SH. Superlift-Einrichtung. Hauptauslegerlängen: 42-96 m.
<b>SSL / LSL:</b> (SGL 94,5 m)	Hauptausleger: Fußstück 12 m, Zwischenstücke 6 m, 10,5 m und 12 m (Typ 2822), Reduzierstück, verlängert um Zwischenstücke 6 m und 12 m (Typ 2822), Spitze 7,5 m. Superlift-Einrichtung. Hauptauslegerlängen: 102-150 m.
<b>SWSL / SFSL:</b>	Hauptausleger: wie SH. Vorneigung 87° bis 45°. Wippbarer Hilfsausleger: wie SW. Superlift-Einrichtung. Hauptauslegerlängen: 48-96 m. Hilfsauslegerlängen: 30-108 m.
<b>SFVL:</b>	Hauptausleger: wie SH. Superlift-Einrichtung. Starrer Hilfsausleger: Fußstück 4,5 m, Zwischenstück 12 m (type 3328), mit zusätzlichem SFVL-Kopf. Hauptauslegerlängen: 48-72 m. Hilfsauslegerlänge: 18 m.
<b>LFVL:</b>	Hauptausleger: wie SH. Superlift-Einrichtung. Starrer Hilfsausleger: Fußstück 4,5 m, Reduzierstück, Spitze 7,5 m. Hauptauslegerlängen: 48-96 m. Hilfsauslegerlänge: 18 m.
<b>+ LF:</b>	Zusätzlich zu SH, SH/LH, SSL oder SSL/LSL. Starrer Hilfsausleger: Fußstück 6 m, Zwischenstücke 12 m (Typ 1815), Spitze 6 m. Hilfsauslegerlängen: 12-36 m. Vorneigung: 10°, 20° und 30°.
<b>Auslegerverbolzung</b>	Serienmäßig hydraulisch verbolzbare Auslegerteile.
<b>Einscherwinde</b>	Auf Oberwagen angebaut.
<b>Sicherheitseinrichtungen</b>	Elektronischer Lastmomentbegrenzer, Hubendschalter, Endschalter für Auslegerbewegungen, hydraulische Ausleger-Rückfallsicherungen, Windmesser.

**ZUSATZAUSRÜSTUNG**

<b>Superlift-Einrichtung Standard</b>	Mast 40,5 m (Typ 2322), Gegengewichtstraverse mit max. 450 t. Superlift-Radien 15, 18, 21, 24 m.
<b>Superlift-Einrichtung Variabel</b>	Mast 40,5 m (Typ 2322), Gegengewichtstraverse mit max. 450 t. Superlift-Radius stufenlos von 15 bis 24 m im Betrieb verstellbar. Vertikalzylinder und Stabilisierungswinde.
<b>Superlift mit Gegengewichtswagen</b>	Mast 40,5 m (Typ 2322), Gegengewichtswagen mit max. 450 t. Superlift-Radius stufenlos von 18 bis 24 m im Betrieb verstellbar.
<b>Seilwinde H3</b>	Zusätzliche Seilwinde im Hauptausleger (zum Betrieb mit LF oder Runner). Seilzug wie H1, Seillänge 700 m.
<b>Runner 46 t</b>	Ca. 2 m zum Anbau an Kopf oder Spitze.

**5**

## DESCRIPTIF TECHNIQUE

### CHÂSSIS À CHENILLES

<b>Partie centrale</b>	Le châssis à chenilles consiste en trois parties – deux chenilles et la partie centrale avec les stabilisateurs plié pour le transport. Les chenilles et la partie centrale sont verrouillées hydrauliquement facilitant ainsi le montage et démontage pour diminuer la largeur d'encombrement et le poids de transport.
<b>Trains de chenille</b>	Structure mécano-soudée rigide à la flexion et à la torsion, réalisée en acier de construction à grains fins à haute résistance.
<b>Chenilles</b>	Structure mécano-soudée rigide à la flexion, réalisée en acier de construction à grains fins à haute résistance. Graissage centralisé automatique inclus de série.
<b>Chenilles</b>	Chaque trains de chenille est équipée de 15 galets d'appui dont les surfaces de roulement sont trempées. Chaque barbotin est entraîné par moteurs hydrauliques avec réducteurs planétaires en carter étanche sous bain d'huile. Chaque côté permet un mouvement réglable sans paliers individuel et dans le sens opposé.
<b>Entraînement</b>	Les barbotins sont entraînés par deux moteurs hydrauliques de chaque côté muni de réducteurs planétaires, sous bain d'huile, en carter étanche, avec freins d'arrêt à commande par ressorts, desserrés hydrauliquement. Grâce à leur compacité extrême, les réducteurs s'intègrent complètement dans la largeur des chenilles. Chaque chenille permet un mouvement individuel et opposé. Entraînement quadro en série.
<b>Lest central</b>	80 t.

### PARTIE SUPÉRIEURE

<b>Contrepoids</b>	250 t.
<b>Charpente</b>	Construction mécano-soudée, rigide à la flexion et à la torsion en acier de construction de haute résistance à grains fins.
<b>Moteur et transmission</b>	Deux moteurs diesel DaimlerChrysler, type OM 460 LA, 6 cylindres, en action avec redondance intégrée et refroidi par eau, 2 x 315 kW (428 CV) à 1800 1/min. Le moteur satisfait aux règlements EUROMOT 3a, EPA T3 et Carb. Réservoir de carburant: 1500 l.
<b>Tambours</b>	L'équipement standard de la partie tournante comprend trois tambours – treuil no 1, no 2 et mécanisme de relevage. Les tambours sont entraînés par des moteurs hydrauliques munis de réducteurs planétaires, sous bain d'huile, en carter étanche. Tous les tambours sont pourvus de freins à disques multiples à commande par ressorts, et desserrés hydrauliquement. Freinage anti-usure hydraulique pour descendre la charge. Les pattes de câble H 1, 2, 3 et W 1, 2 sont équipées des attaches à jonction rapide. Treuils H 1 et H 2 et chevalet avec mécanisme de relevage sont démontables pour diminuer le poids de transport.
<b>Chevalet</b>	Système de relevage hydraulique à la partie supérieure pour chevalet en série.
<b>Mécanisme d'orientation</b>	Entraîné par quatre moteurs hydrauliques avec réducteur planétaire, sous bain d'huile, en carter étanche. Frein d'arrêt à commande par ressorts, desserré hydrauliquement ainsi que freinage anti-usure hydraulique.
<b>Commande</b>	Demag IC-1 : Pilotage électronique de soupapes proportionnels intégré dans un automate programmable avec diagnostic de dysfonctionnement. Deux écrans couleur, commande du C.E.C. par écran tactile. Les vitesses de travail sont réglées sans paliers par la position du levier. Régulation automatique pour une exploitation optimale de la puissance du moteur. En série limitation de portée, force de pression sur base et indicateur des forces de calage.
<b>Cabine</b>	Cabine confortable avec large pare-brise et climatisation. Vitrage de sécurité, fenêtre de toit, chauffage à air autonome, organes de commande et instruments de contrôle. Cabine inclinable en arrière assurant au grutier une visibilité optimale. Une caméra est installée pour la surveillance des treuils. Pendant le transport, la cabine est basculée à l'avant de la partie tournante.
<b>Installation électrique</b>	Système 24 V (2 accumulateurs 12 V / 180 Ah).
<b>Connexion rapide</b>	Connexion rapide hydraulique entre châssis et partie tournante permettant le démontage facile pour réduire le poids de transport en série.

### EQUIPEMENTS OPTIONNELS

<b>Cylindre hydraulique pour le chevalet</b>	Pour le montage des trains de chenille.
<b>Stabilisateur latéral additionnel</b>	Pour le montage des flèches longues.
<b>Chariot contrepoids</b>	Poids total max. 450 t, en combinaison avec l'équipement SL télescopique.
<b>Base de calage variante PC</b>	Base de calage 14 x 14 m. Pour l'utilisation alternative aux chenilles.

Équipements optionnels supplémentaires sur demande!

**DESCRIPTIF TECHNIQUE**
**COMBINAISONS DE FLÈCHE S ET L**

<b>SH:</b>	Flèche principale: pied 12 m, tronçons 6 m, 10,5 m et 12 m (type 3328), tête de flèche 1,5 m. Longueurs de flèche principale: 36-96 m.
<b>SH / LH: (SGL variable)</b>	Flèche principale: pied 12 m, tronçons 6 m, 10,5 m et 12 m (type 3328), tronçon conique, allongée de tronçons 6 m et 12 m (type 2822), tronçon de tête 7,5 m. Longueurs de flèche principale: 48-108 m.
<b>LH:</b>	Flèche principale: pied 12 m, tronçon 10,5 m (type 3328), tronçon conique, allongée de tronçons 6 m et 12 m (type 2822), tronçon de tête 7,5 m. Longueurs de flèche principale: 48-114 m.
<b>SW:</b>	Flèche principale: idem SH. Inclinaison 87° jusqu'à 65°. Fléchette volée variable: pied 4,5 m, tronçon 12 m (type 3328), tronçon conique, tronçon 6 m et tronçons 12 m (type 2822), tronçon de tête 7,5 m. Longueurs de flèche principale: 42-60 m. Longueurs de fléchette: 30-96 m.
<b>SSL:</b>	Flèche principale: idem SH. Équipement Superlift. Longueurs de flèche principale: 42-96 m.
<b>SSL / LSL: (SGL 94,5 m)</b>	Flèche principale: pied 12 m, tronçons 6 m, 10,5 m et 12 m (type 2822), tronçon conique, allongée de tronçons 6 m et 12 m (type 2822), tronçon de tête 7,5 m. Équipement Superlift. Longueurs de flèche principale: 102-150 m.
<b>SWSL / SFSL:</b>	Flèche principale: idem SH. Inclinaison 87° jusqu'à 45°. Fléchette volée variable: idem SW. Équipement Superlift. Longueurs de flèche principale: 48-96 m. Longueurs de fléchette: 30-108 m.
<b>SFVL:</b>	Flèche principale: idem SH. Équipement Superlift. Fléchette fixe: pied 4,5 m, tronçons 12 m (type 3328), SFVL tronçon de tête compris. Longueurs de flèche principale: 48-72 m. Longueur de fléchette: 18 m.
<b>LFVL:</b>	Flèche principale: idem SH. Équipement Superlift. Fléchette fixe: pied 4,5 m, tronçon conique, tronçon de tête 7,5 m. Longueurs de flèche principale: 48-96 m. Longueur de fléchette: 18 m.
<b>+ LF:</b>	En plus SH, SH/LH, SSL ou SSL/LSL. Fléchette fixe: pied 6 m, tronçons 12 m (type 1815), tronçon de tête 6 m. Longueurs de fléchette: 12-36 m. Inclinaison 10°, 20° et 30°.
<b>Boulonnement de flèche</b>	Boulonnement hydraulique des intercalaires de flèche en série.
<b>Tambour de mouflage</b>	Monté sur la partie tournante.
<b>Sécurités</b>	Contrôleur d'état de charge électronique, contacteur de fin de course haut, limiteurs de mouvements de la flèche, retenues hydrauliques anti-basculement de la flèche, anémomètre.

**EQUIPEMENTS OPTIONNELS**

<b>Équipement Superlift standard</b>	Mât 40,5 m (type 2322), panier du contrepoids pour max. 450 t. Rayons du Superlift 15, 18, 21, 24 m.
<b>Équipement Superlift variable</b>	Mât 40,5 m (type 2322), panier du contrepoids pour max. 450 t. Rayon du Superlift variable de 15 à 24 m. Cylindre vertical et système de stabilisation pour le contrepoids Superlift.
<b>Superlift avec chariot contrepoids</b>	Mât 40,5 m (type 2322), chariot contrepoids pour max. 450 t. Rayon du Superlift variable de 18 à 24 m.
<b>Treuil H3</b>	Tambour supplémentaire sur la flèche principale (à utiliser avec LF ou runner). Effort au brin simple idem H1, longueur de câble 700 m.
<b>Runner 46 t</b>	Environ 2 m à installer en tête de flèche ou sur l'élément de pointe.

## KEY · ZEICHENERKLÄRUNG · LÉGENDE

 Track · Spur · Voie

 Counterweight + central ballast (ZB) · Gegengewicht + Zentralballast (ZB) · Contrepoids + lest central (ZB)

 Superlift counterweight · Superlift-Gegengewicht · Contrepoids Superlift

 Superlift radius · Superlift-Radius · rayon Superlift

 Load radius · Lastradius · Portée

 Main boom · Hauptausleger · Flèche principale

 Fly jib · Hilfsausleger · Fléchette

 Main boom angle · Hauptauslegerwinkel · Jarret de flèche principale

 Fly jib angle · Hilfsauslegerwinkel · Jarret de fléchette

„D“ 

S: heavy · schwer · lourd

L: light · leicht · léger

H: Main boom · Hauptausleger · Flèche principale

W: Luffing fly jib · Wippbarer Hilfsausleger · Fléchette à volée variable

F: Fixed fly jib · Starrer Hilfsausleger · Fléchette fixe

SL: Superlift

SGL: Heavy base length · Schwere Grundlänge · Longueur de base lourde



Effective Date: June 2008.

Product specifications and prices are subject to change without notice or obligation. The photographs and/or drawings in this document are for illustrative purposes only. Refer to the appropriate Operator's Manual for instructions on the proper use of this equipment. Failure to follow the appropriate Operator's Manual when using our equipment or to otherwise act irresponsibly may result in serious injury or death. The only warranty applicable to our equipment is the standard written warranty applicable to the particular product and sale and Terex makes no other warranty, express or implied. Products and services listed may be trademarks, service marks or trade-names of Terex Corporation and/or its subsidiaries in the USA and other countries and all rights are reserved. „TEREX“ is a registered trademark of Terex Corporation in the USA and many other countries.

Copyright © 2008 Terex Corporation.

Gültig ab: Juni 2008.

Produktbeschreibungen und Preise können jederzeit und ohne Verpflichtung zur Ankündigung geändert werden. Die in diesem Dokument enthaltenen Fotos und/oder Zeichnungen dienen rein anschaulichen Zwecken. Anweisungen zur ordnungsgemäßen Verwendung dieser Ausrüstung entnehmen Sie bitte dem zugehörigen Betriebshandbuch. Nichtbefolgung des Betriebshandbuchs bei der Verwendung unserer Produkte oder anderweitig fahrlässiges Verhalten kann zu schwerwiegenden Verletzungen oder Tod führen. Für dieses Produkt wird ausschließlich die entsprechende, schriftlich niedergelegte Standardgarantie gewährt. Terex leistet keinerlei darüber hinaus gehende Garantie, weder ausdrücklich noch stillschweigend. Die Bezeichnungen der aufgeführten Produkte und Leistungen sind gegebenenfalls Marken, Servicemarken oder Handelsnamen der Terex Corporation und/oder ihrer Tochtergesellschaften in den USA und anderen Ländern. Alle Rechte vorbehalten. „TEREX“ ist eine eingetragene Marke der Terex Corporation in den USA und vielen anderen Ländern.

Copyright © 2008 Terex Corporation.

Date d'effet : le juin 2008.

Les spécifications et prix des produits sont sujets à modification sans avis ou obligation. Les photographies et/ou dessins contenus dans ce document sont uniquement pour illustration. Veuillez vous référer à la notice d'utilisation appropriée pour les instructions quant à l'utilisation correcte de cet équipement. Tout manquement au suivi de la notice d'utilisation appropriée lors de l'utilisation de notre équipement ou tout acte autrement irresponsable peut résulter en blessure corporelle sérieuse ou mortelle. La seule garantie applicable à notre équipement est la garantie standard écrite applicable à un produit et à une vente spécifique. Terex n'offre aucune autre garantie, expresse ou explicite. Les produits et services proposés peuvent être des marques de fabrique, des marques de service ou des appellations commerciales de Terex Corporation et/ou ses filiales aux Etats Unis et dans les autres pays, et tous les droits sont réservés. «TEREX» est une marque déposée de Terex Corporation aux Etats Unis et dans de nombreux autres pays.

Copyright © 2008 Terex Corporation.