

# TECHNICAL DATA

## SERVICE WEIGHT WITHOUT ATTACHMENT

MHL331 E	23–25.7 t
MHL335 E	24–26.7 t

## DIESEL ENGINE

Manufacturer and model	Deutz TCD 4.1 L4
Design	4-cylinder in-line engine
Control	EEC IV
Method of operation	4-cycle diesel, common rail open-combustion-chamber injection, turbocharger with charge cooler
Engine power	115 kW
Rated speed	2000 min <sup>-1</sup>
Displacement	4.1 l
Cooling system	Water and charge air cooling with temperature controlled fan speed
Exhaust gas standard	EPA Tier 4 interim / EU Stage IIIB
Air filter type	Two-stage filter with safety valve
Useable tank capacity	300 l

## ELECTRICAL SYSTEM

Operating voltage	24 V
Battery	2 × 12 V / 110 Ah / 750 A (according to EN)
Lighting system	1 × H3 headlamp on uppercarriage, 1 × H3 headlamp on cab floor, rear marker lights and flashers
Option	Magnet system 13 kW

## TRANSMISSION

Travel speed first gear	max. 5 km/h
Travel speed 2nd gear	max. 20 km/h
Gradeability	max. 45 %
Turning radius MHL331 E	7.0 m
Turning radius MHL335 E	8.2 m

## SLEWING GEAR

Slew ring	Internally geared, double-row ball turning ring
Drive	2-stage planetary gear with integrated multi-disc brake
Uppercarriage swing speed	0–8 min <sup>-1</sup> variable
Rotating interlock	electrically activated
Max. pivoting moment	49 kNm

## UNDERCARRIAGE MHL331 E

Front axle	Planetary drive axle with integrated drum brake, rigidly mounted, max. steering angle: 28°, width ca. 2.500 mm
Rear axle	Oscillating planetary drive rear axle with integrated drum brake and selectable oscillating lock, width ca. 2.500 mm
Outrigger	4-point outrigger
Tires	Solid rubber, elastic tires 8x 10.00-20

## UNDERCARRIAGE MHL335 E

Front axle	Planetary drive axle with integrated drum brake, rigidly mounted, max. steering angle: 27°, width ca. 2.700 mm
Rear axle	Oscillating planetary drive rear axle with integrated drum brake and selectable oscillating lock, width ca. 2.700 mm
Outrigger	4-point outrigger
Tires	Solid rubber, elastic tires 8x 10.00-20

## BRAKES

Service brake	A hydraulically activated single-circuit brake system that works on all four pairs of wheels
Parking brake	Electrically activated disc brake on the travel drive that works on both axes

## HYDRAULIC SYSTEM

Max. Delivery rate	380 l/min
Max. Operating pressure	320 / 360 bar
Hydraulic fluid tank	305 l

## DRIVER'S CAB

Elastic bearings, variable hydraulic height adjustment up to a viewing height of 5.30 m, sound suppressed, large thermal glass windows provide excellent visibility, front windshield with pull-down sunblind that can be slid under the cab roof, inspection window in the cab roof, sliding glass panel in the cab door, steering column tilts and height adjusts.

Heating	Hot water heating with variable temperature adjustment and 3-level blower, 6 adjustable defroster nozzles
Driver's seat	Air-cushioned comfort seat with integrated headrest, safety belt and lower lumbar support, with integrated air conditioning. Multi adjustable seat provides comfortable operation and access to controls.
Monitoring	Ergonomically positioned, glare resistant instrument cluster, multifunction display, automatic monitoring and saving functions for deviating operating conditions (e.g. all hydraulic oil filters, oil temperature indicator, coolant temperature and charge air cooler, coolant level, loading diesel particle filter), optic and audible warning until the pilot control is shut down or the engine power is reduced. Diagnostics for the individual sensors via the multifunction display Rear view camera
Air conditioning system	With automatic temperature control and cooled storage rack.
Sound Power Level	L <sub>W(A)</sub> = 101 dB(A) (guaranteed) in accordance with guideline 2000/14/EC, required in accordance with 2000/14/EC = 104 dB(A)

## OFFICIAL HOMOLOGATION

Certification in accordance with CE guidelines.

# EQUIPMENT

ENGINE	STANDARD	OPTION
Turbocharger	●	
Charge Air Cooler	●	
Electronic direct fuel injection / Common Rail	●	
Auto-idling system	●	
Engine preheater		●
Engine diagnostics interface	●	
Temperature controlled fan drive	●	
Mode switchover (Eco-, Eco+ -, Power-Mode)	●	

UNDERCARRIAGE	STANDARD	OPTION
2 speed power shift gear	●	
4-point outrigger	●	
Individually controllable 4-point outrigger		●
Outrigger cylinder with integrated shut-off valves on both sides	●	
4-wheel drive	●	
Piston rod protection for the outrigger cylinders	●	
Stabilizer plates 500 × 350 mm	●	
Pendulum axle locking rear axles	●	
Dozer blade in addition to the 4-point outrigger		●
Special paint (e.g. multi colour)		●
Drum brakes	●	
Tool box	●	

UPPERCARRIAGE	STANDARD	OPTION
Electric refueling pump		●
Light protection		●
Maintenance bonnet, activated by gas with mechanical fuse	●	
Lockable cleaning access openings on radiators	●	
Divided cooling system for an ambient temperature of up to 50°C	●	
Separate oil cooler with temperature controlled fan drive	●	
Central lubrication system, automatic	●	
Rear view camera	●	
Drive alarm with flashing beacon		●
Special paint (e.g. multi colour)		●
Quick-drain valve on the diesel tank	●	
Quick-drain valve on the hydraulic oil tank	●	
Quick-drain valve on the water cooler	●	
Quick-drain valve on the engine sump	●	
Reversing fan for engine and hydraulic oil cooler		●

CAB	STANDARD	OPTION
Automatic engine shutdown		●
Height adjustable for cab system	●	
3-layer glass with protection film	●	
Front windshield, slidable	●	
Sliding window in the cab door	●	
Hinged roof opening	●	
Reinforced glass (front windshield and skylight)		●
Washer and wiper system	●	
Windscreen washer under front windshield		●
Air-cushioned driver's seat with headrest, safety belt, and lower lumbar support	●	
Seat heater with integrated air conditioning		●
Tilting and adjustable steering column	●	
Joystick steering		●
Air conditioning system	●	
Multifunction display	●	
Document clip	●	
Protective front and roof grating		●
Terex® Fuchs Telematics System		●
Voltage converter 12 V		●
Radio 24 V (CD & USB)		●
12 V socket		●
Powder fire extinguisher in cab		●
Flashing beacon		●

EQUIPMENT	STANDARD	OPTION
11 kW DC generator with control and isolation monitoring		●
13 kW DC generator with control and isolation monitoring		●
Close-range expansion for dipper stick	●	
Level controller for coolant and hydraulic oil level	●	
Tool filter system		●
Hose rupture valves for lift cylinder		●
Hose rupture valves for dipperstick cylinder		●
Overload warning device		●
Quick coupling on the dipperstick	●	
Dipperstick impact protection		●
Cyclone prefactioner for air filter		●
Preheating of hydraulic oil		●
Lubrication of the grab suspension by the central lubrication system	●	
H3 Light packages		●
XENON light packages		●
LED light packages		●

Further optional equipment available on request!

# DIMENSIONS MHL335 E

All dimensions in mm

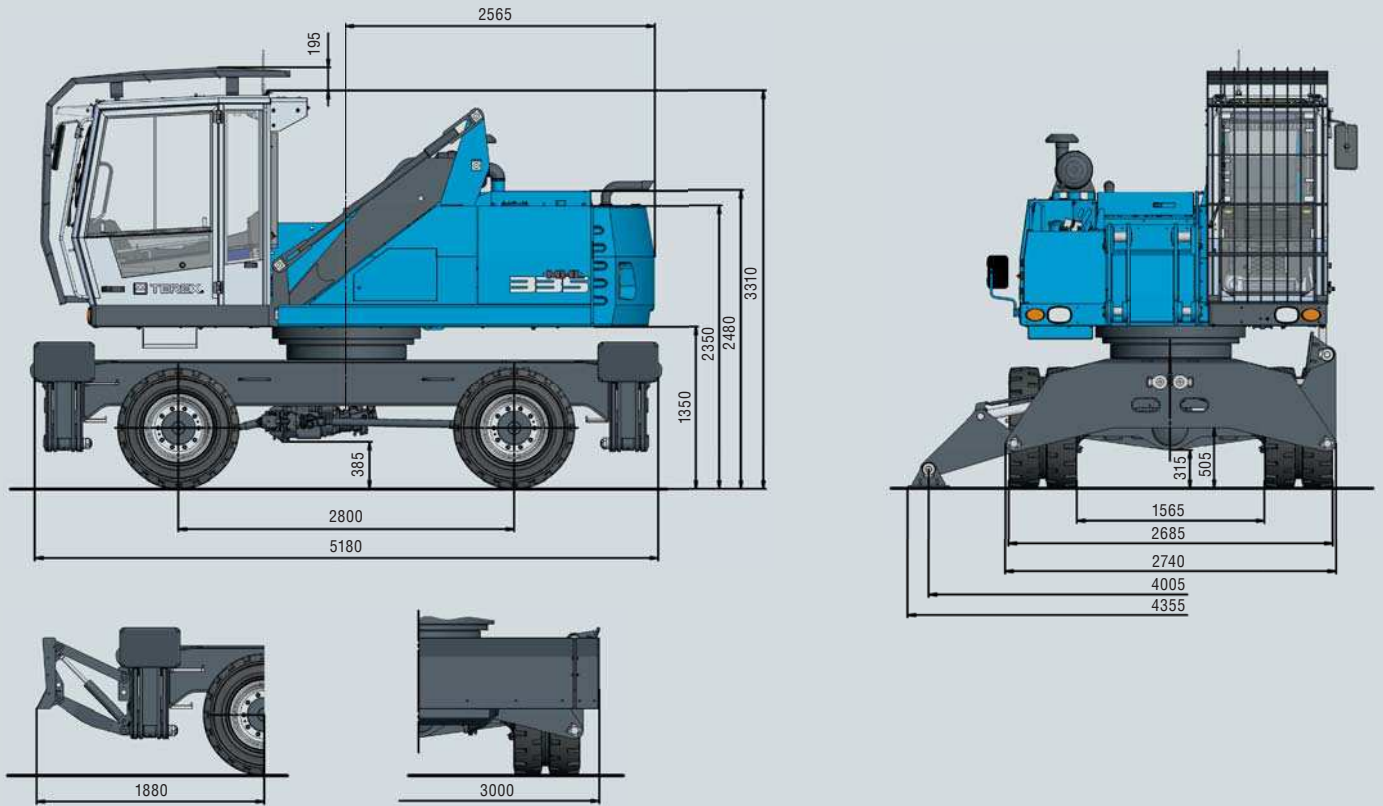

# TRANSPORT DIMENSIONS MHL335 E

All dimensions in mm

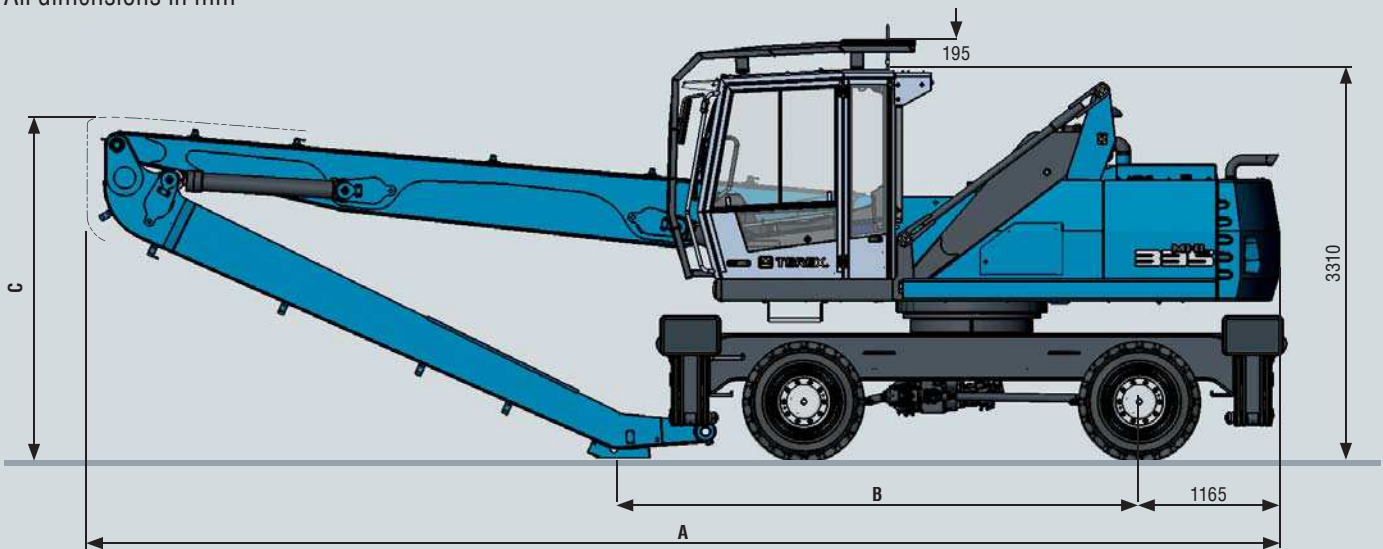

Dimensions	Reach 10.7 m (MZS)	Reach 11.0 m	Reach 12.0 m
A	10.070 mm	10.040 mm	10.045 mm
B	5.565 mm	5.335 mm	4.345 mm
C	2.770 mm	2.770 mm	2.960 mm