

**TEREX®****XM SERIES**
Hi-Ranger Overcenter
Material Handling Aerial Device**AERIAL DEVICES**

Terex® Hi-Ranger Aerial Devices are known throughout the industry. They come with a long history featuring quality and innovative design.

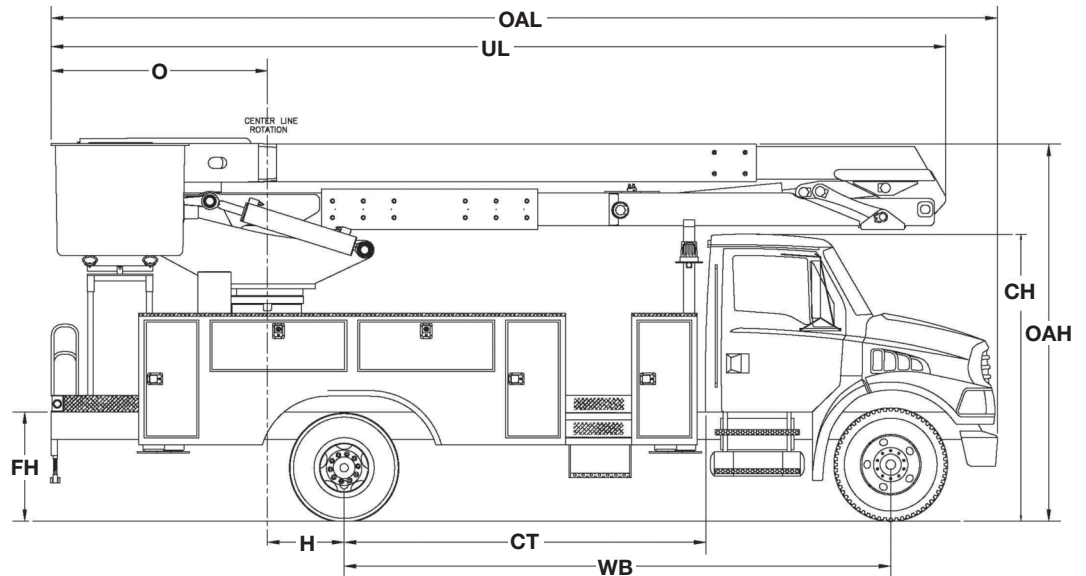

Measurements	XM55	XM60
	ORA	ORA
Typical Frame Height (FH)	40 in. (101.6 cm)	40 in. (101.6 cm)
Typical Cab Height (CH)	108 in. (274.3 cm)	108 in. (274.3 cm)
Offset (O)	81 in. (205.7 cm)	81 in. (205.7 cm)
Overall Height (OAH)	11' 10" (3.6 m)	11' 10" (3.6 m)
Overall Length (OAL)	27' 11" (8.5 m)	29' 6" (9.0 m)
Unit Length (UL)	27' 0" (4.2 m)	29' 6" (9.0 m)
Center of Rotation (H)	6 in. (15.2 cm)	6 in. (15.2 cm)
Cab to Axle (CA)	120 in. (304.8 cm)	138 in. (350.5 cm)
Wheel Base (WB)	192 in. (487.7 cm)	210 in. (533.4 cm)
Front Axle (FA)	12,000 lb. (5,443 kg)	14,000 lb. (6,350 kg)
Rear Axle (RA)	21,000 lb. (9,525 kg)	21,000 lb. (9,525 kg)
Gross Vehicle Weight Rating (GVWR)	33,000 lb. (14,969 kg)	35,000 lb. (15,876 kg)
Recommended Weight for Stability (with Outriggers)	34,000 lb. (15,422 kg)	34,000 lb. (15,422 kg)
Frame Section Modulus	18.0 in ³	18.0 in ³
Frame Yield Strength	50,000 psi	50,000 psi
Frame RBM	900,000 in-lbs	900,000 in-lbs

**TEREX®**

500 Oakwood Drive
PO BOX 1150
Watertown, SD 57201-6150
USA

Phone: (605) 882-4000
Facsimile: (605) 882-1842
www.terexutilities.com
E-mail: utilities.info@terex.com

Distributed By:



XM SERIES

Hi-Ranger Overcenter Material Handling Aerial Device

STANDARD EQUIPMENT

- Single Side-Mounted 24" x 30" x 42" One Person Platform
- Platform Capacity of up to 600 lbs. (272 Kg)
- Control-Plus "3-D" Single Stick at Platform
- Safety Harness With Attached Lanyard
- Continuous Unrestricted Worm Gear Rotation
- Category "C" Rating Per ANSI A92.2
- Rectangular, Bi-Axial Epoxy Resin, Filament Wound Fiberglass Booms
- Individual Lever Lower Controls
- Hydraulic Platform Tilt at Upper and Lower Controls
- Hydraulic Lower, Mechanical Upper Platform Leveling System
- Two Speed Throttle Control at Upper Controls
- 195° of Upper Boom Articulation
- 110° of Lower Boom Articulation
- Full Pressure, Open-Center Hydraulic System
- 35 Gallon Hydraulic Oil Reservoir
- Padded Boom Rests with Upper Boom Tie Down
- Boom Interlock
- Moving Outrigger Alarm
- Truck Level Indicator

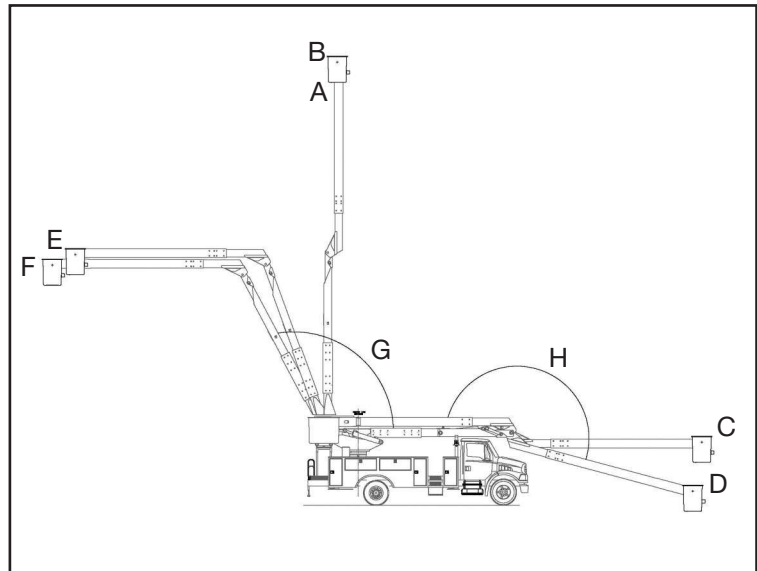

CAPACITIES & DIMENSIONAL DATA (Based on a 40 Inch Frame Height)

	Bottom of Platform Height (A)	Working Height (B)	Overcenter Side Reach (C)	Bottom of Platform to Ground (D)	Non-Overcenter Side Reach at 110° (E)	Non-Overcenter Side Reach at 120° (F)	Lower Boom Articulation at Optional 120° Articulation (G)	Upper Boom Articulation at Optional 120° Articulation (H)
XM55	55.25 ft. (16.9 m)	60.25 ft. (18.4 m)	46.6 ft. (14.2 m)	7.5 in. (19 cm)	40.5 ft. (12.3 cm)	43.5 ft. (13.25 cm)	120°	195°
XM60	60.25 ft. (18.4 m)	65.25 ft. (20.0 m)	51.6 ft. (15.7 m)	14.0 in. (35.6 cm)	43.8 ft. (13.4 cm)	46.9 ft. (14.3 cm)		

OPTIONAL EQUIPMENT

- Various Side Mount Platforms
- Dual Platforms
- Various Platform Covers
- Liners With or Without Steps
- Hydraulic Platform Rotator
- 24" Platform Lifter (Not with Dual Platforms)
- Jib Options
 - Hydraulic Jib Extension Systems
 - Hydraulic Articulating Jib/Winch, Side Mt. 2000 lbs.
 - 115° & 230° Hydraulic Articulating Jib
 - Single Wire/46 Kv Insulated Single Line Lifter / Multi-Phase Attachments
- Category "A" or "B" Rating per ANSI A92.2
- Optional 100° or 120° Lower Boom Articulation
- COMP-SELECT™ Selectable Upper Boom Compensation
- Lower Boom Lifting Eye
- Automatic Upper Boom Latch
- Hydraulic Lifts: 13 ft., 15 ft., and 25 ft.
 - Power Assist, Pilot-Operated, Closed Center Hydraulic System on All Hydraulic Lifts
 - Lift Tie Down
- Hydraulic Tool Outlets
- Engine Stop/Start
- Auxiliary Power
- Auxiliary Let Down System
- Demand Throttle
- Boom Overstow Protection
- Boom/Boom Stow Interlock
- Boom Storage Warning Light
- Outrigger Sag Lights
- Various Types of Outriggers
- Truck Grounding Cable & Clamp
- Hybrid Enable
- HyPower™ Hybrid System by Terex®

Effective Date: March, 2010. Product specifications and prices are subject to change without notice or obligation. The photographs and/or drawings in this document are for illustrative purposes only. Refer to the appropriate Operator's Manual for instructions on the proper use of this equipment. Failure to follow the appropriate Operator's Manual when using our equipment or to otherwise act irresponsibly may result in serious injury or death. The only warranty applicable to our equipment is the standard written warranty applicable to the particular product and sale and Terex makes no other warranty, express or implied. Products and services listed may be trademarks, service marks or trade-names of Terex Corporation and/or its subsidiaries in the USA and other countries. All rights are reserved. Terex® is a registered trademark of Terex Corporation in the USA and many other countries. Copyright 2010 Terex Corporation.

