

## Geschwindigkeiten • Speeds • Vitesses

FU 45-80/5		t = → 1.5 min.	45.0 kW	400 V
SR 10-155/3		v = 0 → 25 m / min.	2 x 10.0 kW	
K WB 80/4		v = 0 → 0.75 min <sup>-1</sup>	L1-L3 L4-L5 1 x 80 Nm 2 x 80 Nm	
HK max. 7 - Lagen / 7 - layers / 7 - couches				

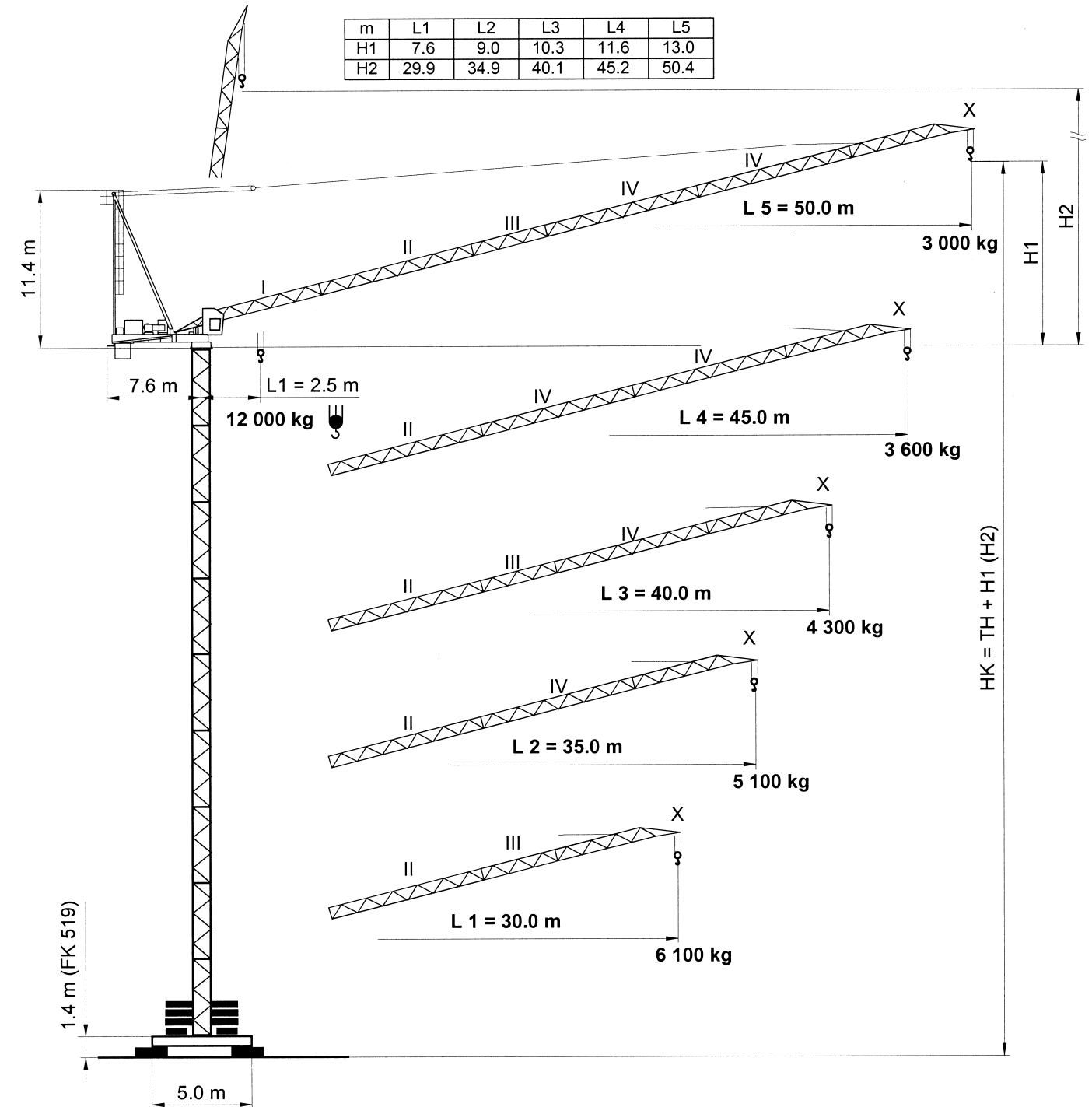
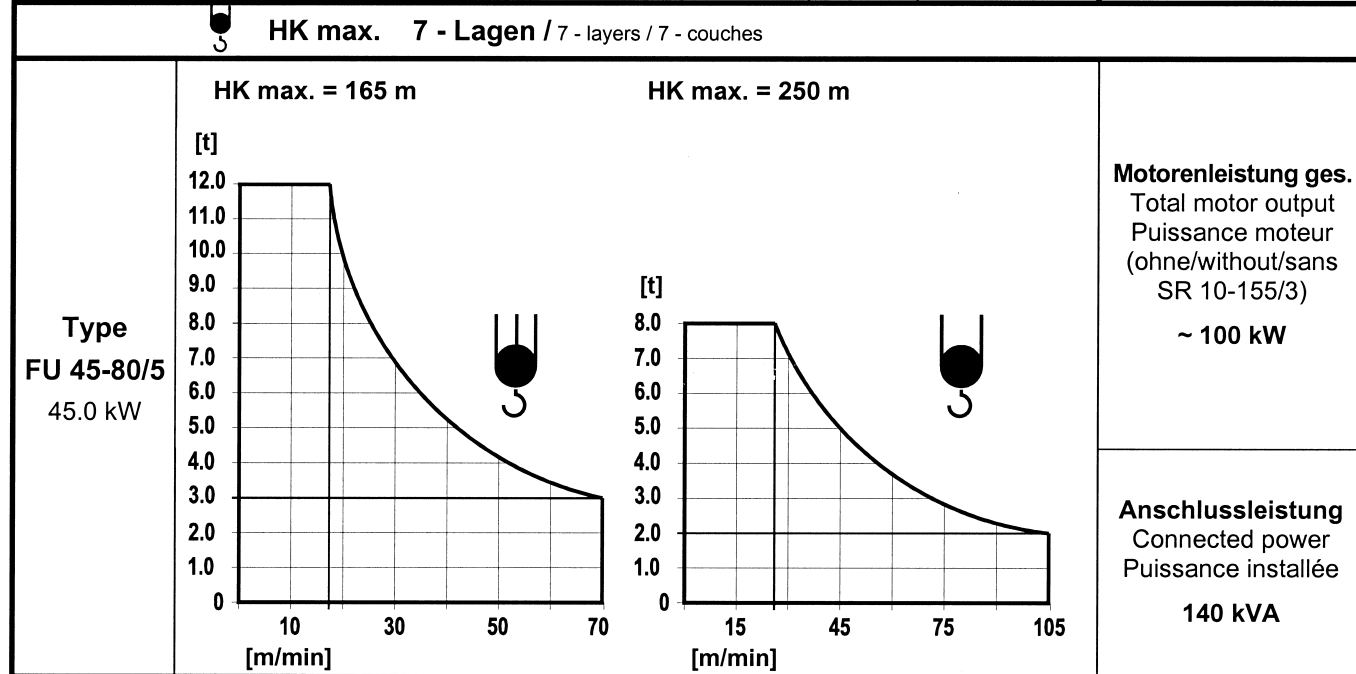

Unsere Vertretung:  
Our representative:  
Notre représentant:

**TEREX PEINER GmbH**  
Gottbillstraße 1-7 · D-54294 Trier  
Telefon: ++49 (6 51) 81 00 8 - 0  
Telefax: ++49 (6 51) 8 93 00 u. 8 76 40  
internet: <http://www.terex-peiner.de>  
e-mail: [info@terex-peiner.de](mailto:info@terex-peiner.de)



*simple, available and cost effective™*

DIN / FEM

Max. Tragfähigkeit  
Lifting capacity  
Force de levage

12.0 t

## Turmversionen • Tower versions • Versions de tours

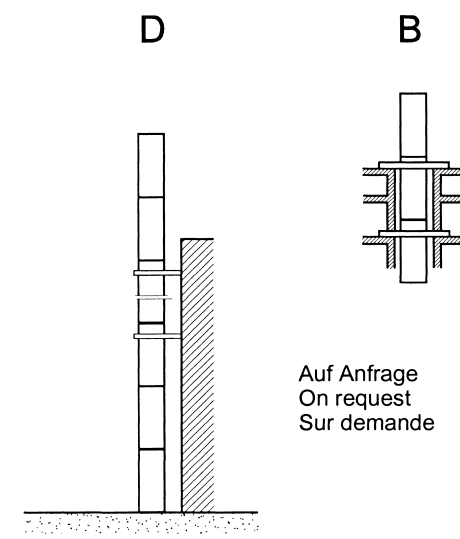
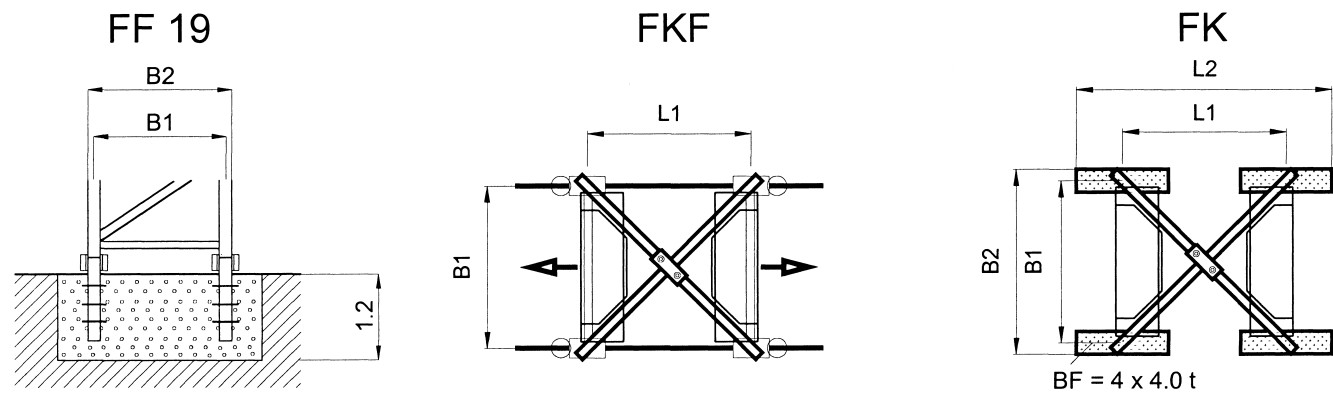
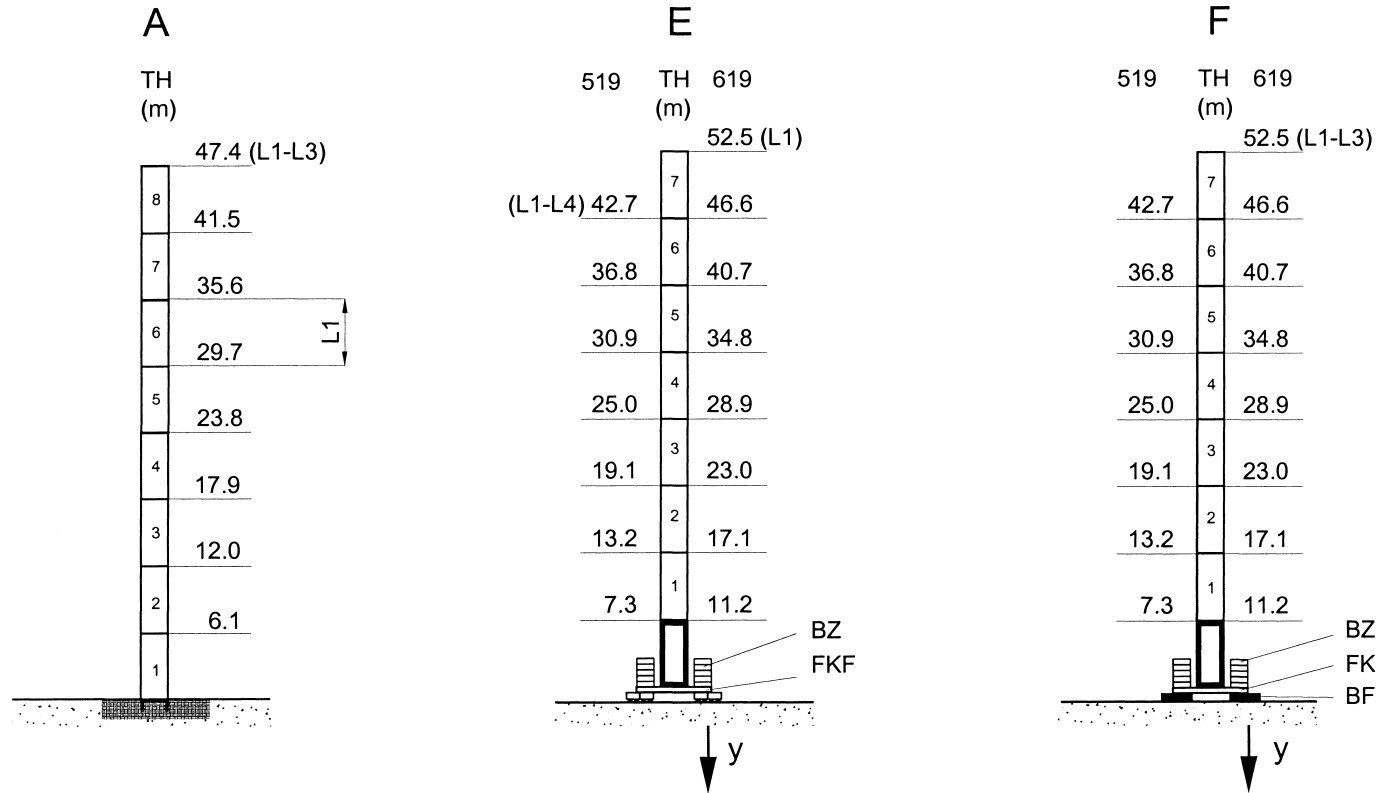

	B1	B2	L1	L2	y / ●	y / ■
	m				kN	
FK 519	5.05	5.75	5.05	7.85	925	1302
FK 619	5.00	6.05	5.05	7.85	899	1221
FKF 519	5.00		5.05		971	1174
FKF 619	5.05		5.05		910	1045
TS 19.1	1.90	2.06	5.90			
TS 19.2	1.90	2.06	11.80			
TSV 19.1	1.90	2.06	5.90			

● in Betrieb / in operation / en service  
■ außer Betrieb / out of operation / sans service

## Ausladung und Tragfähigkeit • Radius and capacity • Portée et charge

Ausleger Jib Flèche	Max. Tragfähigkeit Max. Capacity Charge max.	⤴	Ausladung (m) und Tragfähigkeit (t) Radius (m) and capacity (t) Portée (m) et charge (t)												
m	12.0 t		18	20	23	25	28	30	33	35	38	40	43	45	48
<b>L5 50.0</b>	<b>5.0 - 13.7m/73.1°</b>	9.0	8.1	6.9	6.3	5.5	5.1	4.6	4.3	3.9	3.7	3.4	3.2	2.9	2.8
<b>L4 45.0</b>	<b>4.4 - 14.5m/70.2°</b>	9.5	8.5	7.3	6.7	5.9	5.4	4.9	4.6	4.1	3.9	3.6	3.4		
<b>L3 40.0</b>	<b>3.7 - 15.4m/56.5°</b>	10.4	9.1	7.8	7.1	6.3	5.8	5.2	4.9	4.5	4.2				
<b>L2 35.0</b>	<b>3.1 - 15.7m/62.5°</b>	10.6	9.3	8.0	7.3	6.4	5.9	5.3	5.0						
<b>L1 30.0</b>	<b>2.5 - 15.8m/57.6°</b>	10.6	9.4	8.0	7.3	6.5	6.0								
<b>m</b>	<b>8.0 t</b>	⤴													
<b>L5 50.0</b>	<b>5.0 - 20.4m/66.1°</b>	8.0	8.0	7.0	6.4	5.7	5.2	4.7	4.4	4.0	3.8	3.5	3.3	3.0	2.9
<b>L4 45.0</b>	<b>4.4 - 21.5m/61.8°</b>	8.0	8.0	7.4	6.8	6.0	5.6	5.0	4.7	4.3	4.0	3.7	3.5		
<b>L3 40.0</b>	<b>3.7 - 22.8m/56.0°</b>	8.0	8.0	7.9	7.2	6.4	5.9	5.3	5.0	4.6	4.3				
<b>L2 35.0</b>	<b>3.1 - 23.2m/49.6°</b>	8.0	8.0	8.0	7.4	6.5	6.1	5.4	5.1						
<b>L1 30.0</b>	<b>2.5 - 23.4m/41.0°</b>	8.0	8.0	8.0	7.4	6.6	6.1								
<b>m</b>	<b>4.0 t</b>	⤴													
<b>L5 50.0</b>	<b>5.0 - 39.0m/66.1°</b>	4.0	4.0	4.0	4.0	4.0	4.0	4.0	4.0	4.0	3.9	3.6	3.4	3.1	3.0
<b>L4 45.0</b>	<b>4.4 - 41.0m/61.8°</b>	4.0	4.0	4.0	4.0	4.0	4.0	4.0	4.0	4.0	4.0	4.0	3.8	3.6	
<b>L3 40.0</b>	<b>3.7 - 40.0m/56.0°</b>	4.0	4.0	4.0	4.0	4.0	4.0	4.0	4.0	4.0	4.0	4.0			
<b>L2 35.0</b>	<b>3.1 - 35.0m/49.6°</b>	4.0	4.0	4.0	4.0	4.0	4.0	4.0	4.0	4.0					
<b>L1 30.0</b>	<b>2.5 - 30.0m/41.0°</b>	4.0	4.0	4.0	4.0	4.0	4.0	4.0	4.0						

## Ballastierung • Ballast • Lest

**Version F – mit Zentralballast und Fundamentballast / with Central ballast block and Foundation block / avec Lest de base et Bloc de fondation – BZ + BF**

HH	(m)	7.3	13.2	19.1	25.0	30.9	36.8	42.7	
FK 519	(t)	58.2	68.2	68.2	78.2	88.2	108.2	128.2	
HH	(m)	11.2	17.1	23.0	28.9	34.8	40.7	46.6	52.5 (L1-L3)
FK 619	(t)	48.2	48.2	48.2	58.2	68.2	88.2	108.2	128.2

**Version E – mit Zentralballast / with Central ballast block / avec Lest de base – BZ**

HH	(m)	7.3	13.2	19.1	25.0	30.9	36.8	42.7 (L1-L4)	
FKF 514-L1	(t)	62.2	72.2	82.2	92.2	102.2	112.2	122.2	
HH	(m)	11.2	17.1	23.0	28.9	34.8	40.7	46.6	52.2 (L1)
FKF 619-L2+L3	(t)	52.2	52.2	62.2	72.2	72.2	92.2	112.2	122.2

## Gegengewichtsballast • Counterweight • Contrepoids

Ausleger / Jib / Flèche	L1	L2	L3	L4	L5
<b>BG</b>	15.0	15.0	15.0	15.0	15.0
(t)	2 x 2.50 2 x 5.00	2 x 2.50 2 x 5.00	2 x 2.50 2 x 5.00	2 x 2.50 2 x 5.00	2 x 2.50 2 x 5.00

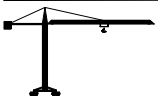

SN 166

•→001



3.1 / 99

12.10.

**02.02 1/2 Packing list**

Number	Designation	Sketch	Length l [m / ft]	Broad b [m / ft]	Height h [m / ft]	Weight t / kips
1	Boom section 1		<b>9.07</b> 29'-9"	<b>2.06</b> 6'-9"	<b>1.66</b> 5'-10"	<b>1.57</b> 3.5
1	Boom section 2		<b>10.48</b> 34'-5"	<b>1.75</b> 5'-9"	<b>1.62</b> 5'-4"	<b>1.13</b> 2.5
	Boom section 3		<b>5.35</b> 17'-7"	<b>1.75</b> 5'-9"	<b>1.60</b> 5'-3"	<b>0.48</b> 1.1
	Boom section 4		<b>10.48</b> 34'-5"	<b>1.75</b> 5'-9"	<b>1.60</b> 5'-3"	<b>0.93</b> 2.1
1	Boom tip		<b>9.23</b> 22'-2"	<b>1.75</b> 5'-7"	<b>2.09</b> 6'-11"	<b>1.15</b> 2.5
1	Luffing rope block		<b>0.70</b> 2'-4"	<b>0.55</b> 1'-10"	<b>0.55</b> 1'-10"	<b>0.17</b> 0.4
1	Load block		<b>1.00</b> 3'-3"	<b>0.93</b> 3'-1"	<b>0.25</b> 0'-10"	<b>0.42</b> 0.9
1	Cabin with platform and railing		<b>2.56</b> 8'-5"	<b>1.42</b> 4'-8"	<b>2.19</b> 7'-2"	<b>0.62</b> 1.4
1	Electrical panel platform		<b>4.95</b> 16'-3"	<b>1.07</b> 3'-6"	<b>2.04</b> 6'-8"	<b>1.49</b> 3.3
1	A - frame cpl. without ladder		<b>11.12</b> 36'-6"	<b>1.91</b> 6'-3"	<b>1.06</b> 3'-6"	<b>3.89</b> 8.6
1	Turntable with slewing ring		<b>8.44</b> 27'-8"	<b>2.10</b> 6'-11"	<b>2.35</b> 7'-9"	<b>9.44</b> 20.8
1	Hoist winch FU 45 without rope		<b>1.96</b> 6'-5"	<b>1.74</b> 5'-9"	<b>1.01</b> 3'-4"	<b>2.03</b> 4.5
1	Luffing winch FU 45 without rope		<b>2.30</b> 7'-7"	<b>1.73</b> 5'-8"	<b>1.07</b> 3'-6"	<b>2.15</b> 4.7
1	Counterweight carriage		<b>3.60</b> 11'-10"	<b>0.73</b> 2'-5"	<b>1.28</b> 4'-2"	<b>0.76</b> 1.7





SN 166

•→001



3.1 / 99

12.10.

**02.02 2/2 Packing list**

Number	Designation	Sketch	Length l [m / ft]	Broad b [m / ft]	Height h [m / ft]	Weight t / kips
	Counterweight <b>BG</b>	(Steel)	1.7 5'-7" 1.7 5'-7" 1.0 3'-3"	0.22 0'-9" 0.44 1'-5" 0.22 0'-9"	3.05 10'-0" 3.05 10'-0" 2.62 8'-7"	2.50 5.5 5.00 11.0 3.75 8.3
	Tower section <b>TS 19.1</b>		5.93 19'-5"	2.10 6'-11"	2.06 6'-9"	2.55 5.6
1	Tower section <b>TSV 19.1</b>		5.93 19'-5"	2.10 6'-11"	2.06 6'-9"	2.81 6.19
1	Tower section <b>TSV 19k</b>		10.64 34'-11"	2.61 8'-7"	2.61 8'-7"	5.82 12.83
1	Tower section <b>TS 19.2</b>		11.83 38'-10"	2.10 6'-11"	2.06 6'-9"	5.18 11.42
1	Foundation cross folded <b>FK 619</b> <b>FK 519</b>		8.89 29'-2" 7.58 24'-10"	1.74 5'-9" 1.36 4'-6"	0.55 1'-10" 0.95 3'-1"	2.78 6.13 5.40 11.9
2	Bogie Driven Not driven		1.50 4'-11" 1.01 3'-4"	0.75 2'-6" 0.31 1'-0"	0.61 2'-0" 0.55 1'-10"	0.48 1.07
	Central ballast block <b>BZ</b>		4.00 13'-1 3.50 11'-6"	1.35 4'-5" 1.50 4'-11"	0.65 2'-2" 0.67 2'-2"	6.10 13.5 5.00 11.0
	Foundation block <b>BF</b>		2.80 9'-2"	1.00 3'-3"	0.57 1'-10"	4.00 8.8
div.	Accessories in boxes					1.0 2.2

