



**TEREX®**

**FACTORY APPROVED ATTACHMENTS**

# BACKHOE LOADER ATTACHMENTS



## **Extend your machine's versatility**

Using Terex factory approved attachments can increase the productivity and functionality of your machine. The extensive range of attachments available for Terex® Backhoe Loaders are quick to fit, easy to use and built to last.

## **What this means for you**

- ▶ High performance attachments that are easy to use and maintain
- ▶ Increase your versatility and job site capability
- ▶ Maximise your up time and receive an excellent return on your investment

**WORKS FOR YOU.™**

## BACKHOE LOADER ATTACHMENTS RANGE

# BACKHOE BUCKETS



### TLB840

#### What this means for you

- ▶ Standard and heavy duty buckets feature total rotation of 196° with extending dipper. Available with reversible side cutters and bolt on teeth
- ▶ Ditch cleaning bucket long and shallow in design and used without teeth

#### Applications

- ▶ Standard bucket suitable for excavating light materials including sand and earth
- ▶ Heavy duty bucket suitable for concrete and road maintenance
- ▶ Trapezoidal bucket suitable for cutting new ditches and maintaining existing drains
- ▶ Ditch cleaning bucket primarily used for shaping and contouring existing ditches

## ORDERING REFERENCE AND SPECIFICATIONS

Direct Pin on Trenching Buckets			
Width mm (in) approx.	Capacity m <sup>3</sup> (ft <sup>3</sup> )	Weight in kg (lbs)	Order Reference
300 (12)	0.10 (3.3)	131 (289)	BALLBR12HDPW2
400 (16)	0.12 (4.2)	145 (320)	BALLBR16HDPW2
450 (18)	0.14 (5.0)	156 (343)	BALLBR18HDPW2
600 (24)	0.20 (7.2)	184 (405)	BALLBR24HDPW2
760 (30)	0.26 (9.5)	209 (460)	BALLBR30HDPW2
915 (36)	0.33 (11.8)	234 (515)	BALLBR36HDPW2
Direct Pin on Ditching and Grading Buckets			
760 (30)	0.10 (3.3)	131 (289)	BALLBR12HDPW2
915 (36)	0.12 (4.2)	145 (320)	BALLBR16HDPW2
1067 (42)	0.14 (5.0)	156 (343)	BALLBR18HDPW2
1220 (48)	0.20 (7.2)	184 (405)	BALLBR24HDPW2
1370 (54)	0.26 (9.5)	209 (460)	BALLBR30HDPW2
1525 (60)	0.33 (11.8)	234 (515)	BALLBR36HDPW2

# HYDRAULIC BREAKER



## TLB840

### What this means for you

- ▶ Terex® hydraulic hammers are designed to provide extended, low maintenance operation with minimal down time. Every hammer in the range is vibra-silenced to offer compliance with the latest standards of operator safety and comfort

### Applications

- ▶ Suitable for rock breaking, road maintenance and demolition applications

## ORDERING REFERENCE AND SPECIFICATIONS

Description	Maximum Energy Per Blow J (ft-lbs)	Required Flow L/Min (gpm)	Carrier Weight t	Order Reference
TXH1400S Breaker	1,400 (1,033)	80-110 (21-29)	7.5-11.0	TXH1400SP-USA
TXH1100S Breaker	1,100 (811)	65-100 (17-27)	5.0-8.5	TXH1100SP-USA

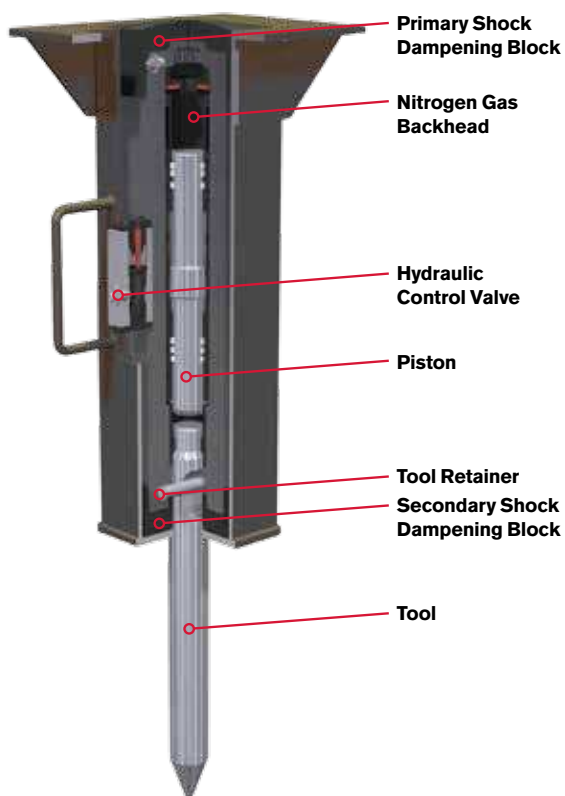

# BACKHOE LOADER ATTACHMENTS RANGE

# AUGER



## TLB840

### What this means for you

- ▶ Heavy duty planetary drive motor for powerful auger performance
- ▶ Suitable for dipper mounting or by quick attach
- ▶ Wide range of auger bits and extensions for complete jobsite compatability
- ▶ Available with an offset cradle mounting

### Applications

- ▶ Suitable for a wide range of jobs including drilling holes for fencing, construction footings and tree planting

## ORDERING REFERENCE AND SPECIFICATIONS

Auger Drives	
Flow Required lpm (gpm)	Order Reference
50-100	T102685
75-150	T102686
Auger Bits	
Description mm (in) approx.	Order Reference
150 (6)	T102689
230 (9)	T102690
250 (10)	T102691
300 (12)	T102692
380 (15)	T102693
450 (18)	T102694
500 (20)	T102695
600 (24)	T102696
760 (30)	T102697
915 (36)	T102678

Auger Extensions	
Description mm (in) approx.	Order Reference
300 (12)	6195785M91
450 (18)	6195786M95
600 (24)	6195787M91
900 (35)	6195788M91
1220 (48)	6195789M91
1850 (73)	6195790M91

# QUICK ATTACH



## TLB840

### What this means for you

- ▶ Mechanical or hydraulic locking available
- ▶ Hydraulic excavator quick attach enables changing of attachments and buckets from the operators seat without leaving the cab

### Applications

- ▶ Designed to couple and uncouple standard buckets and attachments, transforming a backhoe into a multi-tool carrier

## EXCAVATOR QUICK ATTACH ORDERING REFERENCE AND SPECIFICATIONS

Description	Order Reference
Hydraulic Quick Attach (extendable dipper)	H200ACC44B
Hydraulic Quick Attach	H200ACC44E
Hydraulic Quick Attach (standard dipper)	H200ACC43E
Mechanical Quick Attach	6114796M91
Semi Automatic	6108811M92
Autolatch	T101115
Total Lock (Hydraulic with 20 second delay)*	T116277
Springlock (manual)*	T104977

## TLB840

### What this means for you

- ▶ Simple design
- ▶ Mechanical locking
- ▶ Picks up standard and 7 in 1 loader buckets

### Applications

- ▶ Designed to couple and uncouple standard buckets and attachments, transforming a backhoe into a multi-tool carrier

## LOADER QUICK ATTACH ORDERING REFERENCE AND SPECIFICATIONS

Description	Order Reference
Manual Quick Coupler	T102660

## BACKHOE LOADER ATTACHMENTS RANGE

# LOADER BUCKETS



### TLB840

#### What this means for you

- ▶ Standard bucket with curved profile ensures rapid fill and discharge for high productivity
- ▶ Multi-purpose bucket provides complete job site versatility for enhanced utilisation
- ▶ Available with a choice of bolt on teeth or reversible cutting edge

#### Applications

- ▶ Suitable for a wide range of applications including digging, lifting, loading, dozing, scraping, spreading and levelling

## ORDERING REFERENCE AND SPECIFICATIONS

Description	Width mm (ft)	Weight kg (lbs)	Capacity m <sup>3</sup> (yd <sup>3</sup> )	Order Reference
Standard Loader Bucket with Fork Brackets	2,311 (7.7)	400 (880)	1.0 (1.32)	6108216M91
Standard Loader Bucket with Fork Brackets	2,387 (7.10)	430 (946)	1.2 (1.57)	6108217M91
Multi Purpose Loader Bucket	2,311 (7.7)	730 (1,606)	1.0 (1.32)	6106218M93
Multi Purpose Loader Bucket	2,387 (7.10)	767 (11,687)	1.2 (157)	6106283M93

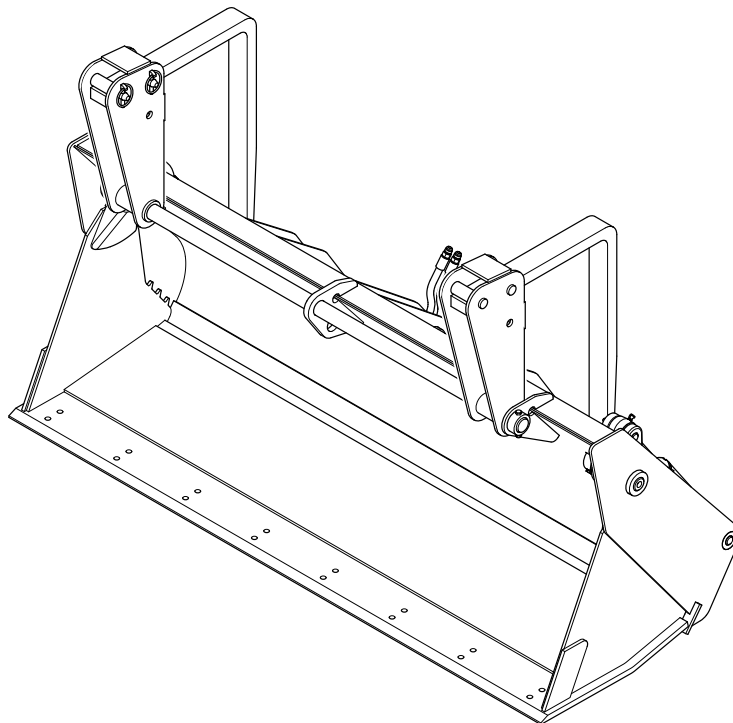

# HIGH-TIP BUCKET



## TLB840

### What this means for you

- ▶ Dump height of 4.10m (161in)

### Applications

- ▶ Low capacity/high density bucket suitable for larger rocks, construction and demolition waste
- ▶ Medium capacity/medium density bucket suitable for grain, refuse, general purpose
- ▶ High capacity/low density bucket suitable for soil, sand, aggregate, ore

## ORDERING REFERENCE AND SPECIFICATIONS

Description	Capacity struck m <sup>3</sup> (heaped capacity m <sup>3</sup> )	Order Reference
Low capacity/high density bucket	0.81 (0.98)	T102667
Medium capacity/medium density bucket	1.16 (1.44)	T102668
High capacity/low density bucket	1.72 (2.07)	T102669
Optional bolt on cutting edge	-	T102670

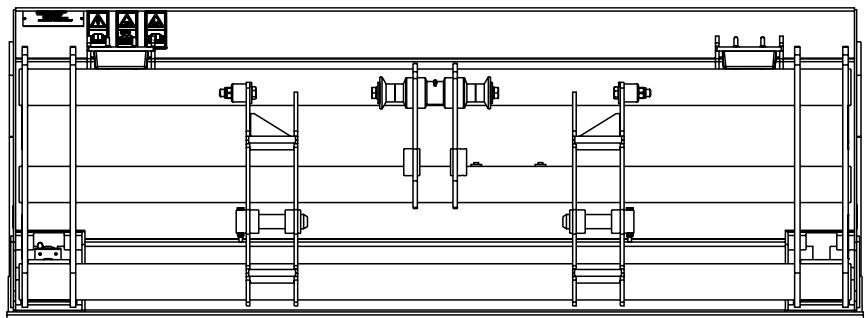
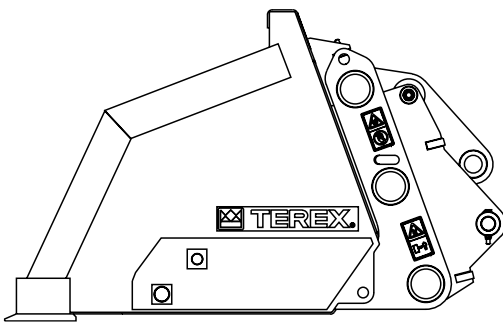

## BACKHOE LOADER ATTACHMENTS RANGE

# PALLET FORKS



### TLB840

#### What this means for you

- ▶ Safe working load at 500mm load centre 2500kg (5500lb)
- ▶ Class 2B 100mm (4in) x 40mm (1.6in)
- ▶ Weight 228kg (502lb)

#### Applications

- ▶ For handling palletised loads

## ORDERING REFERENCE AND SPECIFICATIONS

Description	Weight kg (lbs)	Safe Working Load at 500mm (20 in) kg (lbs)	Order Reference
Pallet Forks	228 (502)	2,500 (5,500)	T102674

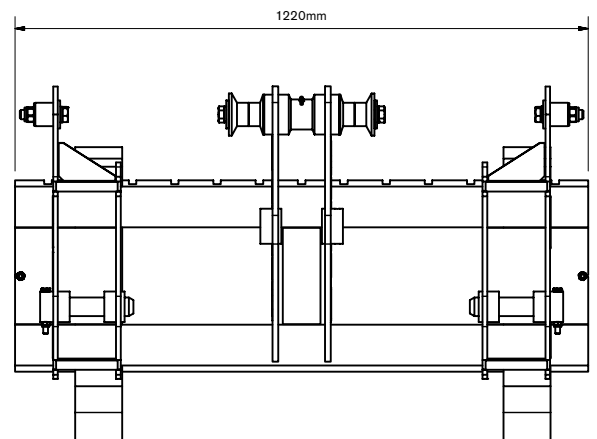
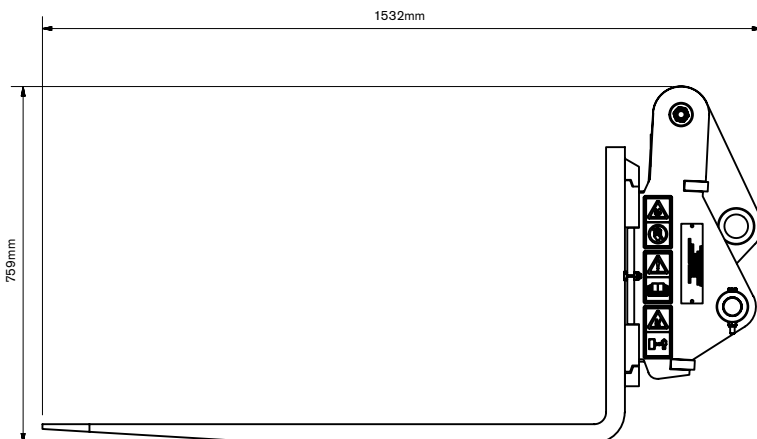
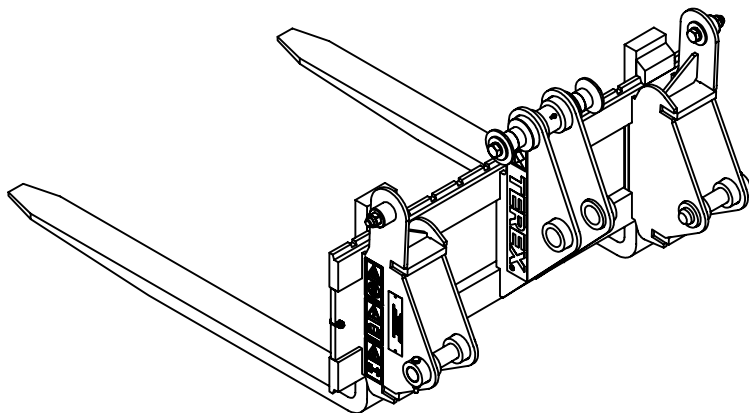



# BROOM BUCKET



## TLB840

### What this means for you

- ▶ Rotary brush sweeps debris into the collector bucket . To discharge, simply tip the bucket and reverse the action of the brush
- ▶ Max flow 76L/min (16.9gpm)
- ▶ Maximum pressure 207bar (3000psi)

### Applications

- ▶ Suitable for clearing yards, roads, sidewalks. Also efficient for snow removal
- ▶ Dust suppression kit reduces airborne particles resulting from broom bucket action
- ▶ Gutter brush kit effectively clears curb side drains

## ORDERING REFERENCE AND SPECIFICATIONS

Description	Capacity m <sup>3</sup> (yd <sup>3</sup> )	Order Reference
Broom Bucket	0.58 (0.76)	T102675
Dust Suppression Kit	-	T102676
Gutter Brush Kit	-	T102677

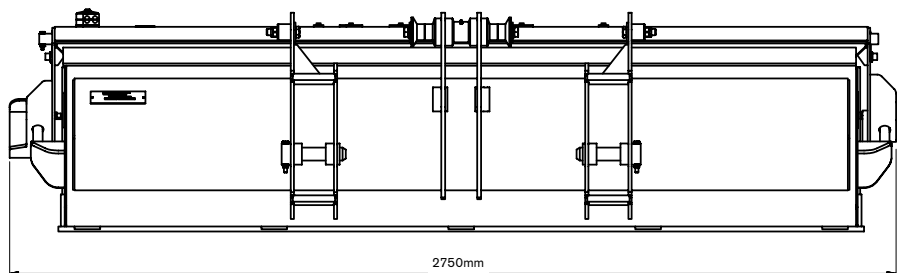
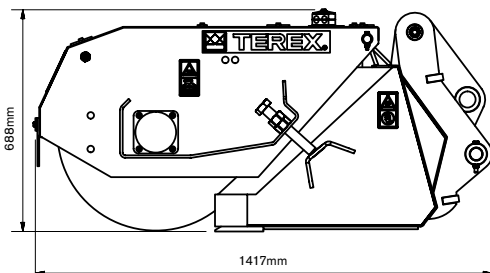
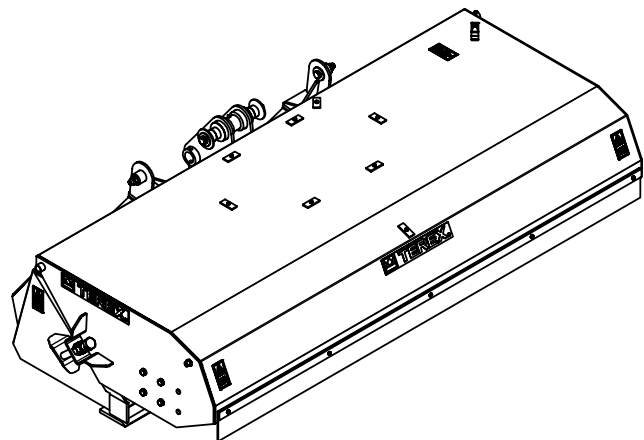

## BACKHOE LOADER ATTACHMENTS RANGE

# FARM FORK AND GRAPPLE



### TLB840

#### What this means for you

- ▶ Steel in body, sides and support framework
- ▶ Dual cylinder twin grapple

#### Applications

- ▶ Suitable for agricultural activities including muck, bale and silage handling. Also suitable for industrial applications

## ORDERING REFERENCE AND SPECIFICATIONS

Description	Capacity m <sup>3</sup> (ft <sup>3</sup> )	Weight kg (lbs)	Order Reference
Farm Fork and Grapple	1.72 (2.25)	515 (1,133)	T102684

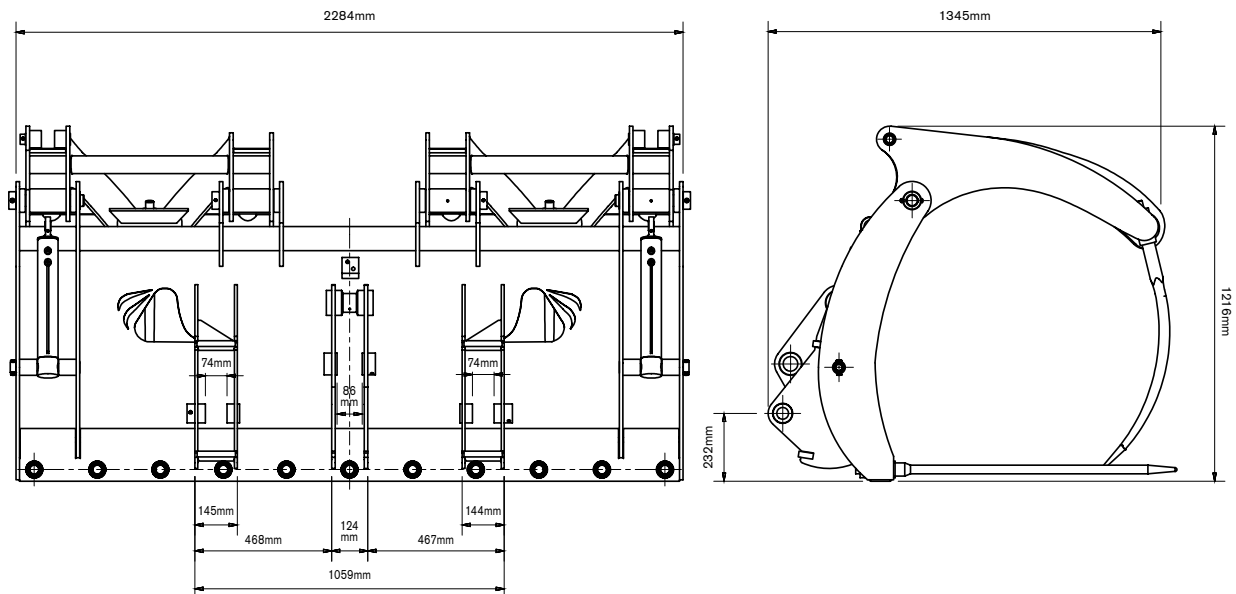

# SNOWPLOUGH



## TLB840

### What this means for you

- ▶ 30° angle of movement to both right hand and left hand sides
- ▶ Replaceable bolt on scraper blade for extended use & road surface protection

### Applications

- ▶ For the efficient clearing of snow on roads

## ORDERING REFERENCE AND SPECIFICATIONS

Description	Order Reference
Snowplough with wheel kit	T117472

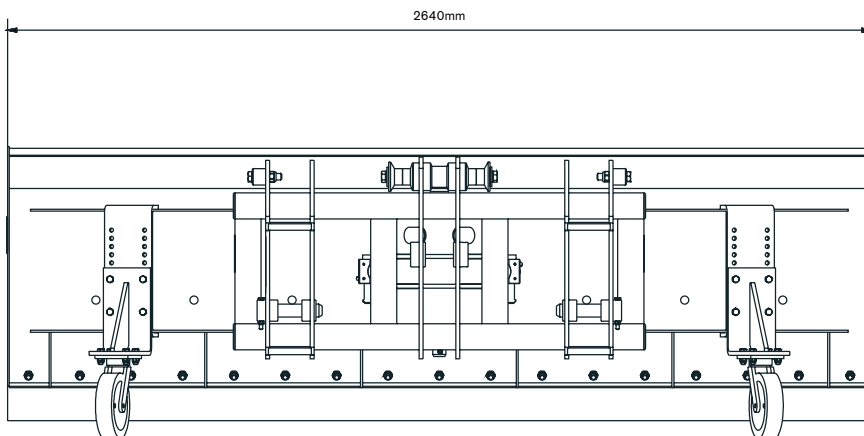
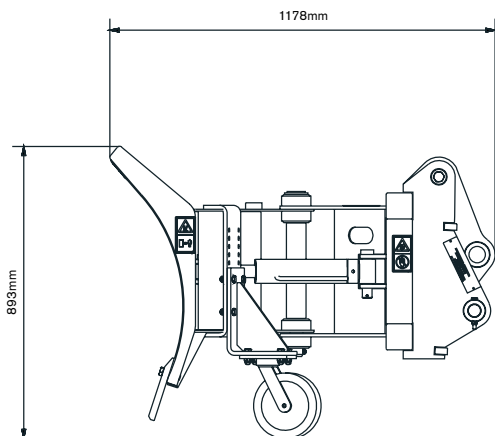

[www.terexparts.com](http://www.terexparts.com)

Effective Date: September 2013. Product specifications and prices are subject to change without notice or obligation. The photographs and/or drawings in this document are for illustrative purposes only. Refer to the appropriate Operator's Manual for instructions on the proper use of this equipment. Failure to follow the appropriate Operator's Manual when using our equipment or to otherwise act irresponsibly may result in serious injury or death. The only warranty applicable to our equipment is the standard written warranty applicable to the particular product and sale and Terex makes no other warranty, express or implied. Products and services listed may be trademarks, service marks or trade-names of Terex Corporation and/or its subsidiaries in the USA and other countries. All rights are reserved. Terex is a registered trademark of Terex Corporation in the USA and many other countries.  
© 2013 Terex Corporation. (R2\_090113)

Ref. No: TEREX667NA

Terex Construction 8800 Rostin Road, Southaven, MS 38671 USA  
Tel +1 (888) 90-TEREX [www.terex.com](http://www.terex.com)



**WORKS FOR YOU.™**