

TERRAMAC® RT14R RUBBER TRACK CARRIER

Standard RT14R Specs

The Terramac® RT14R features a 360-degree rotatable frame along with a 28,000 lb. carrying capacity bed that can dump at any position. This functionality will bring improved efficiencies to the job site while minimizing environmental damage. Ideal for a variety of projects including environmental, general construction and many more.



DIMENSIONS	
Full Length	20'
Full Width	9' 8"
Wheel Base	12' 5"
Min Ground Clearance	24"
Front Overhang	3' 11.5"
Track Width	31.5"
Track Length	15' 1"
Full Height	10' 9"
Height of Rock Bed	7' 5"
Height of Rock Bed Side (Vessel)	21"
Length of Rock Bed (Vessel)	11' 1"
Width of Rock Bed (Vessel)	8' 11.5"
Dumping Angle	60°
Machine Weight (with bed)	40,000 lbs.

ENGINE	
Manufacturer	Cummins
Model	QSL9 T4F
Displacement	543 cu. in.
Horsepower	320 HP
Electrical System	12 VDC
Battery	(2) GRP 31, 2250 CCA
Fuel Capacity	90 gallons

HYDRAULICS	
Transmission	HST
Piston Pump Capacity (x2)	64 gpm / side
Relief Valve Piston Pump	5,600 PSI
Tandem Gear Pump Capacity	
Front Section (HST Drive)	25 gpm @ 500 PSI
Rear Section (Aux Output)	20 gpm @ 2500 PSI

PERFORMANCE	
Max. Carrying Capacity	28,000 lbs.
Travel Speed - 1st Gear	4.0 mph
Travel Speed - 2nd Gear	6.0 mph
Gradability (unloaded)	30%
Turning Radius	10' 8"
Ground Pressure (full capacity)	7.9 PSI
Ground Pressure (unloaded)	4.4 PSI

TERRAMAC® RT14R RUBBER TRACK CARRIER

Standard RT14R Units & Dimensions

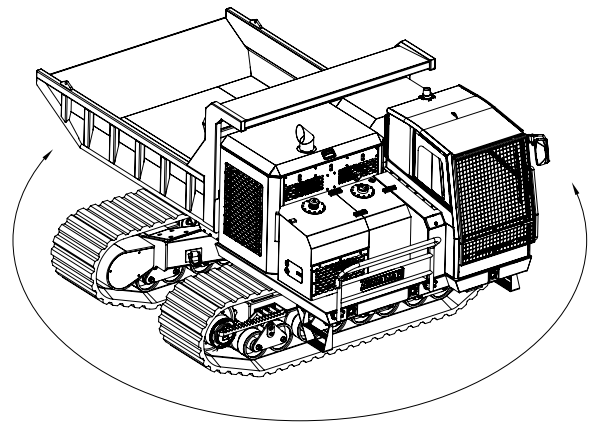
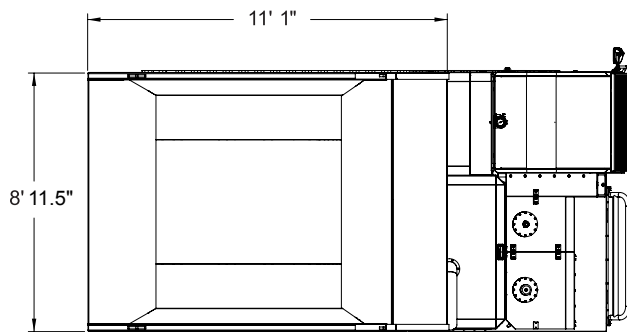
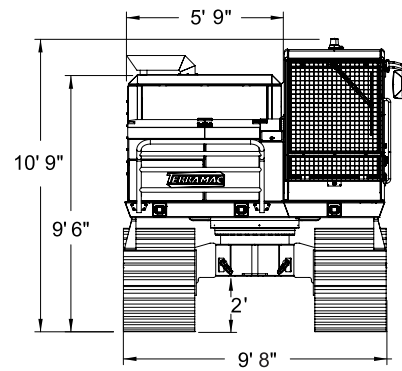
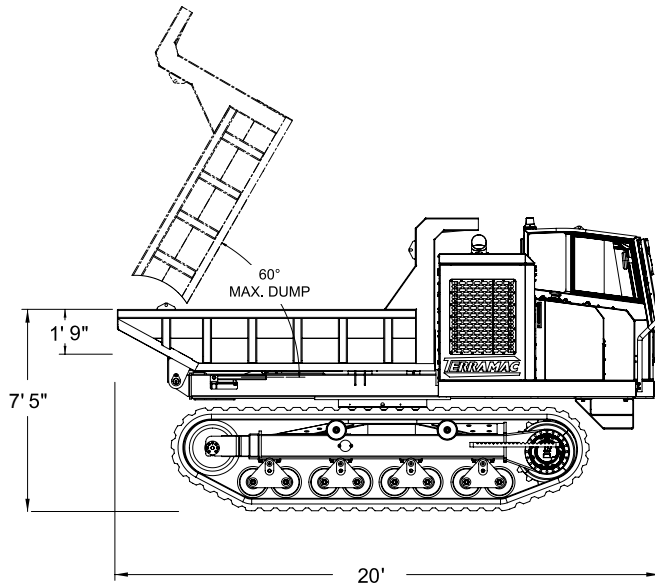

360° upper frame rotation