



IMPORTANT!



READ THIS MANUAL BEFORE OPERATING MACHINE.

OPERATOR'S HANDBOOK, MAINTENANCE, SERVICE &

PARTS MANUAL

TERRAMITE CORPORATIONS

SINCE 1965



STREET SWEEPERS

TSS6 & TSS8

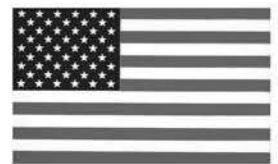

MADE IN THE USA



"Backed by a World of Experience"

600 Goff Mountain Road • P.O. Box 7146, Charleston, WV 25356-7146 USA
1.800.428.3772 Fax 1.800.776.4845 • International 1.304.776.4231 Fax 1.304.776.4845

www.terramite.com

Revised 02/2007

Courtesy of Machine.Market

Table of Contents

SECTION ONE: INTRODUCTION/INFORMATION

Table of Contents 1.1

SECTION TWO: SAFETY GUIDELINES, MACHINE OPERATION AND SERVICE

Safety Guidelines, Machine Operation and Service 2.1
 Safety Guidelines 2.2 to 2.4
 When Operating The Street Sweeper 2.5
 Hazards and Hazardous Areas 2.5
 Transporting the Street Sweeper with a Trailer 2.6
 Towing the Street Sweeper 2.7 to 2.8
 Storing the Street Sweeper 2.9
 Engine Operating Instructions 2.9 to 2.10
 Weather Considerations 2.10
 Periodic Service 2.11
 Engine Oil Service 2.11
 Hydraulic System Service 2.12
 Street Sweeper Lubrication 2.13
 Battery and Tires 2.13
 Paint and Cleaning 2.13 to 2.14
 Trouble Shooting 2.14 to 2.15
 Machine Operation Control Location 2.15 to 2.16
 Lubrication and Maintenance Chart 2.16 to 2.17
 Service and Maintenance Points 2.17
 Machine Trouble Shooting & Hydraulic Component Check-Out 2.17
 Proper Care and Use of Broom Wafers 2.18
 Broom Core Removal/Wafer Replacement 2.19
 Setting and Adjusting Broom 2.20

SECTION THREE: PARTS

Operator's Position & Wafers 3.1
 View from Right Side of Operator's Position 3.2
 View from Left Side of Operators Position 3.3
 View of Front with Tow Bar Extended 3.4
 View of Tow Bar in Detail 3.5
 View of Lower Front 3.6
 View of Front 3.7
 View of Right Front 3.8
 View of Right Side Front 3.9
 View of Right Side Front 3.10
 View of Left Side Front 3.11
 View of Left Side 3.12
 View of Right Side Brush Assembly 3.13
 View of Left Side Brush Assembly 3.14
 View of Lower Right 3.15
 View of Lower Left 3.16
 View of Dash 3.17
 View of Under Dash 3.18
 View of Behind Dash 3.19
 View of Underside of Dash 3.20
 View from Back of Operator's Seat Left Side 3.21
 View from Inside Rear Panel 3.22
 View of Rear Engine Area 3.23
 Rear View of Transmission/Pump Assembly 3.24
 Left Side View of Transmission/Pump Assembly 3.25
 View of Under Seat Area 3.26
 View of Lock Out & Left Side Brush Assembly 3.27
 Front Fork Assembly 3.28
 Water System Routing 3.29
 Sprayer Parts 3.30
 Brush Core 3.31
 Front Hub 3.32
 Pivot Bearing Weldment Assembly 3.33
 Broom Mount Weldment 3.34
 Brush Bar Assembly 3.35
 Brush Bar Cylinder 3.36

Brush Core Motor Mount 3.37
 Brush Core Plate & Block For Motor Assembly 3.38
 Spray Bar Assembly 3.39
 Brake Hub Assembly 3.40
 Brake Hub Assembly 3.41
 Hoses Set Sweeper Parker Valves 3.42
 Hose Set Sweeper Saver Dantoss Valves 3.43
 Hoses 6 ft. Sweeper 3.44
 Low Pressure Filter Assembly & High Pressure 3.45
 Ground Drive Assembly 3.46
 Gear Pump Part # 66000 Gas/66001 Diesel 3.47
 Hyrdastatic Transmission 3.48
 Hyrdastatic Transmission 3.49
 110A Brush Motor Exploded View Parker 3.50
 Kubota Engine 3.51
 Hydraulic Oil Change and Type Specifications 3.52

SECTION FOUR: HYDRAULICS

Hyraulic Schematic #1, Main Propel Drive V1 4.1
 Hyraulic Schematic #2, Steering/Auxiliary V1 4.2
 Hyraulic Schematic #3, Broom Drive V1 4.3
 Hyraulic Schematic #1, Main Propel Drive V2 4.4
 Hyraulic Schematic #2, Steering/Auxiliary V2 4.5
 Hyraulic Schematic #3, Broom Drive V2 4.6
 Hyraulic Schematic #1, Main Propel Drive V3 4.7
 Hyraulic Schematic #2, Steering/Auxiliary V3 4.8
 Hyraulic Schematic #3, Broom Drive V3 4.9
 Wiring Diagram for DIODE Engine 4.10
 Wiring Diagram Cat Engine 4.11
 Wiring Diagram Cat Engine 4.12
 Wiring Diagram Cat Engine 4.13
 Wiring Harness Diagram for the Kubota Engine 4.14

SECTION FIVE: DECALS

Right Side from Operators Position 5.1
 Left Side from Operators Position 5.2
 Right Side from Operators Position 5.3
 Tow Bar 5.4
 Dash 5.5

SECTION SIX: TRANSLATIONS

Translations 6.1 to 6.6

SECTION SEVEN: INDEX

Index 7.1 to 7.3

RECORDS

Serial Number _____
 Model# _____
 Engine Type: _____
 Engine Serial Number: _____
 Accessories: _____

Safety Guidelines, Machine Operation and Service

1. Read all decals (See Decal Section) and manuals before starting and/or operating the Terramite Street Sweeper.
2. Do not make any adjustments or repairs or operate if parking brake does not work, repair the parking brake, first, before making any adjustments or other repairs to this street sweeper.
3. Parking brake must be set before engine is started and after it is stopped.
4. Protective eye wear must be worn while operating/servicing/adjusting this machine or when working within 100 feet of the Terramite Street Sweeper.
5. The Terramite Street Sweeper must not be operated if any person is within working range of the sweeper and/or is not wearing proper protective safety attire.
6. You must disengage both rear wheel lock outs before making any repairs or adjustments.
7. Repairs and or adjustments must not be made with the engine running. Otherwise, the operator must be in his seat with parking brake set, wheel lock-outs disengaged and wearing seat belt.
8. Do not start the Terramite Street Sweeper before inspecting both transmission return to neutral springs. Do not start if spring are not in place and functioning.
9. When servicing any electrical component, always disconnect the negative battery cable first.
10. Safety eye protection and attire must be worn when servicing battery.
11. Never "Jump-Start" the Terramite Street Sweeper.
12. Industrial accepted safety practices must be followed while operating/adjusting/repairing the Terramite Street Sweeper.
13. Towing vehicle must meet or exceed all Federal/State/Local laws for GVWR, lighting and hitch requirements for all places machine will be operated.
14. Do not disconnect any hydraulic hose or fitting until all hydraulic oil has cooled to ambient temperature and machine is turned off. Then move valve handle 6 times in both directions to relieve residual pressure.
15. Do not change direction of the machine quickly. Machine must come to a complete stop before changing directions.
16. Do not tow this machine unless the front tire clears the ground at least 6 inches, and the broom is properly hooked up to an adequate tow vehicle.
17. Use only Federal, State or Locally recommended Tow Bar Safety chains.
18. Machine must not be started/serviced or operated unless you have read and fully understand the manuals.

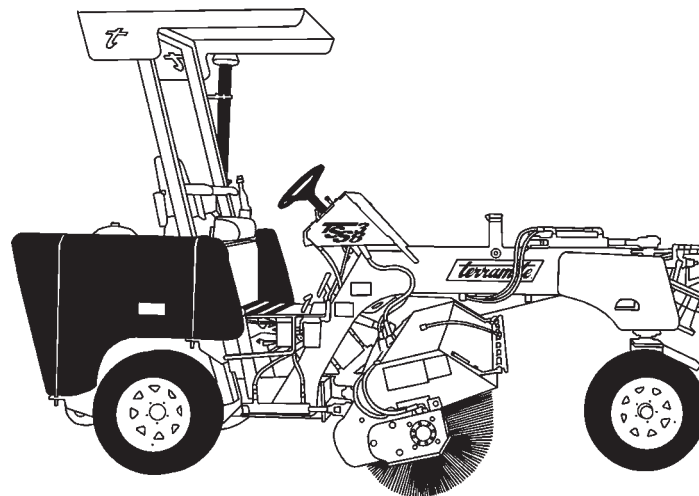

Service Operations

! Safety Guidelines

! Important

In this section there are very important safety rules that you must be aware of before operating any Terramite product. When you see the ! symbol next to a headline, it will indicate that the paragraph contains important safety information.

! For the Beginner

Regardless of whether you have purchased or rented a Terramite Street Sweeper to perform a job that you wish to complete as quickly as possible, it is mandatory that you read through the operating sections of this manual before operating the machine. The few minutes it will take will not only give

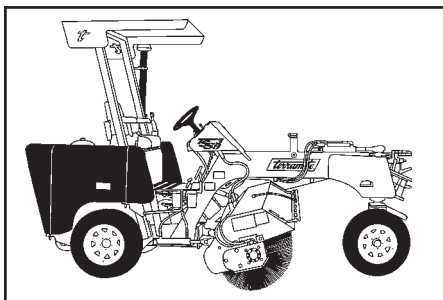

you a solid basis for learning to operate the Terramite Street Sweeper correctly, but you will have the assurance that you are operating the machine in a safe manner. We have made every effort to make the Terramite Street Sweeper the safest machine of its kind in the industry, but that is as far as we can go. The rest is up to you. Please help us by carefully reading this handbook and complying with its safety suggestions.

! If You Must Use the Terramite Street Sweeper Right Now

Without question it is to your advantage and safety that you take the time to follow the operator training suggestions. Only with some guidance can you expect to become a master at the controls of a Terramite Street Sweeper in a reasonably short period. However, if this is not possible, first read the operating and safety rules section of the handbook, then at least practice for about twenty minutes. Just getting used to how the controls function will make your first attempt at working with the machine far more pleasurable, productive and, most important, safe.

! Suggested Training for the Beginner

We believe you will find the training procedures an interesting and very rewarding experience. As you read through the Operator's Handbook, you will note that it is as much a safety guide as it is an instruction manual. Learning the various functions of the machine in a programmed order is the most logical approach to becoming a safe and skilled operator. It will take a little time but it will undoubtedly be the best investment in time and money you can make as a new Terramite Street Sweeper operator and/or owner. Only when the operator has mastered the controls of the machine and is in full command of its capabilities will the owner fully realize the rewards of his investment. Only after the operator has full knowledge of the safety considerations of the Terramite Street Sweeper, which are covered in this handbook, should he be allowed to operator the machine.

! Do I Need an Instructor?

At this point, it is only natural that there be some concern as to whether or not you are taking on something that should require an instructor. There is bound to be some question in your mind as to whether you can possibly hurt the machine or the machine can hurt you. The answer to both questions is definitely YES, but not likely. As to the machine, we have designed the Terramite Street Sweeper to protect itself from exceeding its own limits. As to the operator, we have made every effort to design and build the Terramite Street Sweeper with your safety in mind. As to the beginner, we have no record of anyone being seriously injured while learning to use a Terramite Street Sweeper and, to the best of our knowledge, the vast majority have accomplished it pretty much on their own. However, we feel the first step is to read the Operator's Handbook. This should give you some basis for determining whether you may need personal instruction. If you feel you do, contact your local dealer or call Terramite Corporation: 1-800-428-3772.

! We have your Safety in Mind.

Our experience would indicate that most beginners just climb aboard and start pushing controls. Although it says something about how easy it is to operate the Terramite Street Sweeper, it completely ignores the safety aspects of operating the machines. Even if you have someone assisting you in learning to operate the Terramite Street

Safety Guidelines (continued)

Sweeper, you will have no way of knowing to what degree they have prepared you as to the safety considerations of the machine. **READ THE HANDBOOK!** It may not cover every situation, but it covers those we believe to be most important.

An Excellent Safety Record

In our constant reference to safety, we are well aware that we are creating a false impression that the Terramite Street Sweeper is a dangerous machine to operate. Regardless, our continuous emphasis on safety is intentional, in the hope of making you a safety minded operator. The Terramite Street Sweeper has an excellent safety record, but as with a powerful automobile in the wrong hands, it can be very dangerous. Like the automobile, it is mostly a matter of knowledge, attitude and respect for your own safety and the safety of others that determines the degree of risk.

Driving the Terramite Street Sweeper

Note: Throughout this publication the word “drive” will mean to operate the Terramite Street Sweeper from one place to another. “Operate” will refer to all other functions.

Pre-Operation Inspection

Before starting the engine, check the fuel as well as the engine and hydraulic oil levels, then made a walk-around inspection to determine that everything appears normal. The most important single thing you can do to increase the life of the Terramite Street Sweeper is to properly lubricate the pivot pins. When new, the pivot pins should be lubricated every four hours the first 20 hours, and every eight hours thereafter. If you are going to haul the Terramite Street Sweeper to a job, it is usually a good idea to perform the pre-operation inspection before leaving for the job site. This should include starting the engine and testing each control of the Terramite Street Sweeper as well as driving the Terramite Street Sweeper forward and backward. Do not operate the Terramite Street Sweeper if you believe that there might be a problem. Some minor problems can become major problems if not attended to.

Hydraulic Pressure Considerations

As this may be your first experience with a machine that functions primarily through hydraulic pressure, it is imperative that you be aware of the danger of putting your

hands close to any part of the hydraulic components of the machine while the engine is running or within two minutes after being shut down. Be aware that escaping fluid under pressure can be sufficient force to penetrate the skin, causing serious personal injury. Fluid escaping from a very small hole can be almost invisible. Therefore, we recommend that you wear heavy work clothes that will fully cover your body, leather work gloves and safety eye protection when placing your hands around or near hydraulic lines or fittings while under pressure. If you suspect a leak, it can be quickly detected using a piece of cardboard or wood. If injured by escaping fluid, go to the Emergency Room of the nearest hospital. Be certain to inform them that this type of injury can cause serious infection or a reaction such as gangrene. If there is no hospital in the area, call a physician immediately.

Being Mentally Prepared

Now, before attempting to operate the machine, read through the following paragraphs involving driving the Terramite Street Sweeper and be sure you have a good mental picture of just what you are about to do and how you will do it. Please note that our only goal in this first session is for you to become familiar with the feel of driving a Terramite Street Sweeper and using its' controls.

The Hydraulic Transmission

The Terramite Street Sweeper is a very simple machine to operate but somewhat different than driving a car or truck. This is because everything on a Terramite Street Sweeper is driven by hydraulic pumps. The movements of the broom head, the power steering and even the drive wheels are the result of hydraulic pressure developed by these pumps. The pump is driven by the diesel engine. The drive wheels are powered by a hydrostatic transmission. This transmission is a fluid drive device that provides variable flow at a constant RPM from the engine to develop the range of driving speeds used in performing the Terramite Street Sweeper's tasks. Only when you wish to bring the Terramite Street Sweeper up to its maximum road speed or maximum sweeping power will you need to increase the engine RPM. For most work, all we do is set the throttle at about 3/4 power, or a little less, and leave it. The ground speed and direction of the Terramite Street Sweeper is controlled by the hydrostatic transmission and Forward/Neutral/Reverse valve.

Just a Little Does It

By lightly depressing the foot pedal we develop maximum torque, which develops power like the low gear of a manual

Service Operations

Safety Guidelines (continued)

transmission in a truck. As we depress the foot pedal further, the engine RPM remains about the same, but the Terramite Street Sweeper picks up speed over the ground. The big difference between driving the Terramite Street Sweeper and a truck is that if you want power to start up a hill, you need only depress the foot pedal about a third of the way forward, not to the floor. If you want speed, you start off with a small amount of pedal and keep increasing as the speed builds up and the required torque decreases.

No Gear Shift

When the drive pedal is in neutral position, it's like applying a brake. Anytime the engine tends to slow, let up on the pedal a little. You have to experience it to appreciate it. Although somewhat different in its control, the hydrostatic transmission is very easy to use and very forgiving. It takes only minutes to get used to, and is simpler to use than an automatic transmission in an automobile.

Some "Don'ts"

Excessive RPM can damage the engine and make the controls overly responsive. Do not change the relief valve settings. They are factory set for best machine performance. Do not go from forward to reverse or reverse to forward without pausing at neutral. It may damage the drive train.

Getting Started

Now we are ready to get aboard. Make certain that there is no oil on the steps, which might cause you to slip and fall. Your seat may be adjusted to different positions by pulling the lever located under the seat on the right. Before starting the engine, be sure to fasten your seat belt. Terramite Corporation believes that a seat belt should be worn at all times.

Some Never, Never, Nevers

Never use the Terramite Street Sweeper for a job it wasn't intended to do. Never use any other part of the machine as work platform or a personnel carrier. Never allow anyone to be under, or even close to the broom or any part of the sweeper. Never touch the hydraulic components when, or right after, the machine has been working. They reach temperatures in excess of 200 degrees and can give you a severe burn.

Slow Down, Speed Kills

Be particularly alert when backing or working in crowded areas. Always operate the Terramite Street Sweeper at a safe speed, keeping in mind your safety and that of any other people working in the area.

Not Too Much at One Time

As a beginner, this practice will require your total concentration. Therefore, while learning to use the street sweeper, we recommend that you do not put in over half an hour of practice without a half-hour break. Confusion and panic can be brought on from mental exhaustion, which can occur very rapidly until the use of the controls becomes a somewhat automatic reaction. Long sessions, requiring extreme concentration, can be potentially dangerous.

Working on a Slope (Use Extreme Caution)

Now we will cover one of the most important considerations in operating the Terramite Street Sweeper. Naturally, you will be working on some degree of ground slope much of the time unless you live in very flat country. We feel it is extremely important that we impress upon you just how treacherous a slope can be when using this machine, particularly under certain conditions. If you operate on a hillside that is slippery and/or steep enough that there is any question that the Terramite Street Sweeper will not be able to maintain braking action, you will be taking your life in your own hands. Unless you are absolutely sure that you can accomplish the work without risk, do not attempt it. A slick surface, such as dry leaves on even a slight grade, may cause your rear tires to slide out of control without any braking action whatsoever.

Emergency Procedures

Before working a hazardous area such as a hillside, take time to consider every possible problem you might encounter. Be sure you are mentally prepared for any situation and know exactly what you might do in an emergency. Remember, panic is your worst enemy, and panic usually comes when you are caught completely off guard and unprepared. Safety conscious operators run through emergency procedures before operating under any conditions that give them concern.

When Operating the Street Sweeper

First Aid and Fire. Keep a fire extinguisher and a first aid kit nearby and know how to use them.

Loose Clothing. Never take chances by wearing loose clothing, watches or rings. Keep clothing and hands away from moving parts.

Only Room for One. When in operation, only the operator should be permitted on the machine.

Mounting the Machine. Always mount your machine from the side. Put one foot on the machine at a time. Never mount from the rear or while the engine is running. Before you start the engine, always fasten the seat belt. When in operation, do not jump either on or off the machine. Never mount or dismount a moving machine.

Starting the Terramite Street Sweeper. Do not attempt to start or operate the Terramite Street Sweeper except from the operator's station. Never operate the controls from the ground, as this could result in serious injury or even death.

Prevent Accidental Starting. Disconnect the negative wire from the battery. Put a Lock Out Tag on the machine while being serviced. Remove key.

Other Battery Considerations. Do not use the battery charger as a booster to start the engine. Never disconnect

the battery when the engine is running. Never attempt to charge a frozen battery. An explosion may occur.

Operating at Excessive Speed. Operating unit at excessive speeds increases the danger of personal injury. Do not change the governor setting or tamper with components which may increase speed.

Excessive Hydraulic Pressure. Do not raise the hydraulic pressure beyond 2200 PSI. Components may become overloaded and break, causing serious injury. This also shortens the life of your machine.

Excessive Tire Pressure. Never exceed maximum recommended tire pressure, as serious injury or even death may result.

Relief Valve Settings. Do not change the relief valve settings. They are factory set for the best machine performance and safety. If it becomes necessary to adjust this setting, refer to the Terramite Street Sweeper Service Manual for the proper procedure.

Parking Machine. Always park your machine on level ground with parking brake engaged.

Prevent Fire. Be cautious of fire when operating in dry, dead grass or brush.

Hazards and Hazardous Areas

Approved Container. Always use an approved container when handling and storing diesel fuel or solvents.

When Loading Fuel. Never fill the fuel tank while smoking, when near an open flame or with the engine running. Leave room for fuel expansion, 1-1/2 to 2 inches. Replace fuel cap securely.

Cleaning Parts. Never use gasoline or diesel fuel for cleaning parts. Always use a nonflammable solvent.

Overhead Wires. Watch for overhead wires and cables. Never touch the wires with any part of the machine. If you contact an electric line, stay on your machine until help arrives, if you are not being shocked. If you have to jump from the machine, make sure you are not touching the machine as you hit the ground.

Two Men, if Possible. When working in hazardous areas, be extremely alert. If possible, two men should work together, one operating the machine and the other directing

him and watching for dangers. Develop a hand signal system or use hand signals shown on page 1.4.

Unventilated Area. Never operate the Terramite Street Sweeper in an unventilated area. Carbon monoxide and methane gas are colorless and odorless.

Explosion. Sparks can come out of the muffler or the electrical system. Do not operate the machine in areas where there are flammable vapors or dusts that are of the nature that would cause an explosion.

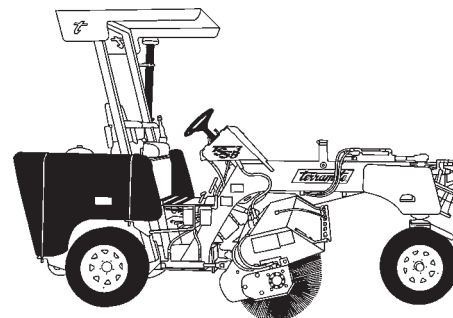

Service Operations

Transporting the Street Sweeper with a Trailer



General Considerations

Proper Towing Equipment. It is important that you use a truck that is capable of towing the trailer and the Terramite Street Sweeper, and that it is equipped with the proper tie-down equipment for securing it to the trailer. When on a road or highway, at night or during the day, use accessory lights and an SMV (Slow Moving Vehicle) sign for adequate warning to other drivers. In this regard, check state and local regulations.



Do Not Wrap Chains Around Cylinder Rods. This may scar or bend them.



MAXIMUM TOWING SPEED WITH A TRAILER IS 60 MPH



Trailer Size and Type

The trailer you select should have a load carrying capacity of at least 7000 pounds with a tandem axle, and at least 14 feet long. You will need to check with State authorities as to whether electric or hydraulic surge brakes are permitted.



Loading Can Be Tricky

After setting the truck's emergency brake and blocking the wheels of the truck and the trailer, drive the machine slowly onto the trailer. Keep in mind that the weight of the Terramite Street Sweeper going onto the trailer may raise the rear of the truck off the ground, causing the truck, trailer and Terramite Street Sweeper to roll forward. Driving onto a tilt bed trailer can also be very tricky as the trailer bed will likely slam down, tending to make you overcompensate by going backwards, thus causing the trailer to seesaw back and forth.



Securing the Terramite Street Sweeper to a Trailer

Once the Terramite Street Sweeper is positioned on the trailer, block each side of the front and rear tires. Using chains, bind it to the trailer. There are binding rings welded onto the frame under the engine and on the front. Always put the binders toward the front and the rear, never straight out. The machine may shift if the binders are placed at 90 degree angles. Measure the height of the machine on the trailer so you will know the minimum height under which you can pass.



CAUTION!

Always place the load binder handles on the right so you can tighten them down without exposing yourself to oncoming traffic. It is good practice to use a piece of tie wire to keep the handle from flying up. Be careful if you use a cheater bar to lock binders down. Fingers have been broken when the binder flings over center. A ratchet binder is the best, followed by over center binders. Come alongs are not very safe due to their poor construction. Make sure all loose items are secured. Be sure to check tightness after you start, and periodically as you travel, as the load may shift.



Towing Considerations for the Terramite Street Sweeper

At highway speeds, if there is too much weight on the back of the trailer, it may suddenly and without notice start whipping violently back and forth. This can be very dangerous and is caused by not having enough weight on the tongue. It can be corrected by properly positioning the Terramite Street Sweeper on the trailer. Too far forward may produce more weight than the hitch or even the truck can handle; whereas, too far back can be dangerous, as described above. It is a good idea to go to a weigh station, and after determining the best position, mark where to park the wheels. You must also be careful as to just where you place any additional cargo you may take along. Most trailer manufacturers recommend that 10% of the weight be on the tongue.



CAUTION!

Test the braking capabilities of the truck and trailer combination on the first clear stretch of road. Most brake controllers can engage the trailer brakes independently of the towing vehicle's brakes. This feature can be used to help straighten out a skid.



Safe Towing Practices

SAFETY FIRST! Always maintain extra distance from the vehicles in front of you and allow extra room when turning corners. Make lane changes slowly to keep the load from shifting, and let other drivers, who may be in your blind spot, get out of your way. Periodically check your trailer and safety equipment. Remember, you are towing the equivalent of a small pickup truck behind you.

Towing the Street Sweeper



General Considerations

Proper Towing Equipment. It is important that you use a truck that is capable of towing the sweeper. When on a road or highway, at night or during the day, use accessory lights and an SMV (Slow Moving Vehicle) sign for adequate warning to other drivers. In this regard, check state and local regulations.



Do Not Wrap Chains Around Cylinder Rods. This may scar or bend them.



MAXIMUM TOWING SPEED IS 60 MPH



Attaching Sweeper To Towing Truck

1. Park truck on level ground, turn off engine, and set parking brake.
2. Drive sweeper near truck. Turn off sweeper engine, set sweeper parking brake (See Figures 1 & 2).
3. Remove tow bar upper locking pin (See Figure 3) and place tow bar in line with sweeper (See Figure 4). Re-attach tow bar upper locking pin, making sure its secure



WARNING!

To prevent injury have someone assist in the removal of the tow bar upper locking pin and lowering of the tow bar.

4. Remove the tow bar lower locking pin (See Figure 4).
5. Start sweeper engine. Helper uses tow bar lift valve (See Figure 5) to raise tow bar to towing truck height.
6. Connect tow bar to towing truck and secure.
7. Use tow bar lift valve to raise front of sweeper until the tow bar lower locking pin can be replaced and secured.
8. Attach safety chains and light cord to towing truck.
9. Place broom assembly in up position and secure with its chain.
10. Turn off engine, release parking brake, and disconnect lock out hubs (See Figures 6 & 7).
11. Drain water tanks (See Figure 8).
12. To prepare broom for service after towing, reverse order of these instructions.



CAUTION!

Test the braking capabilities of the truck with sweeper prior to driving on the road.



Safe Towing Practices

SAFETY FIRST! Always maintain extra distance from the vehicles in front of you and allow extra room when turning corners. Make lane changes slowly, and let other drivers, who may be in your blind spot, get out of your way. Periodically check your sweeper and safety equipment. Remember, you are towing the equivalent of a small pickup truck behind you.

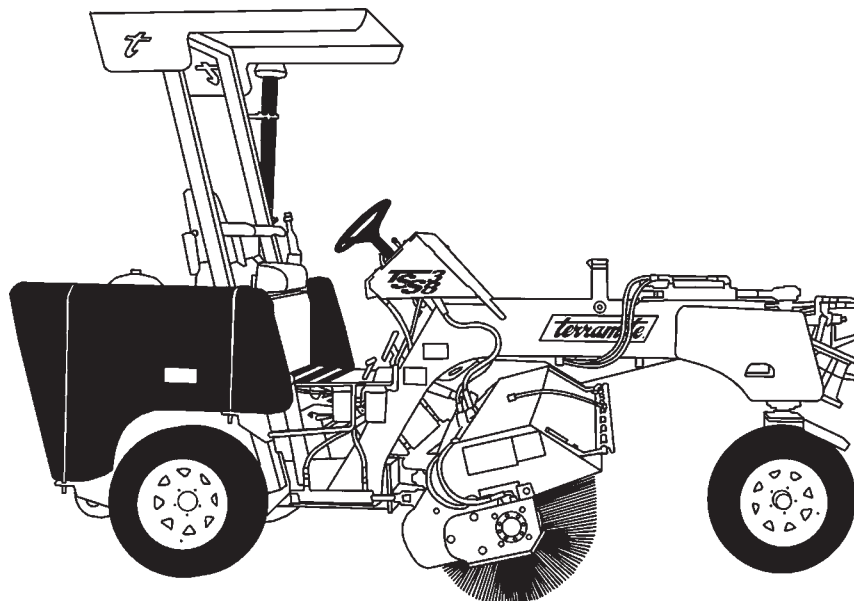

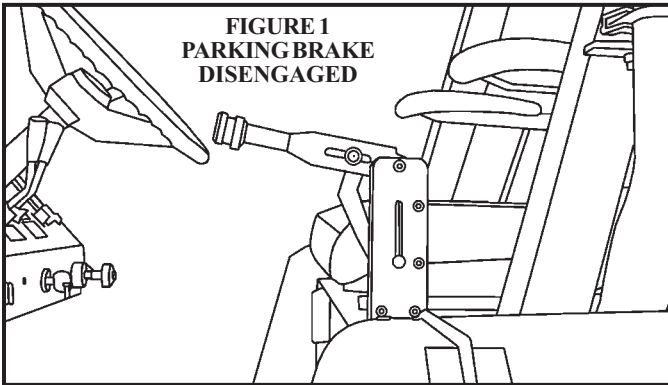

FIGURE 1
PARKING BRAKE
DISENGAGED

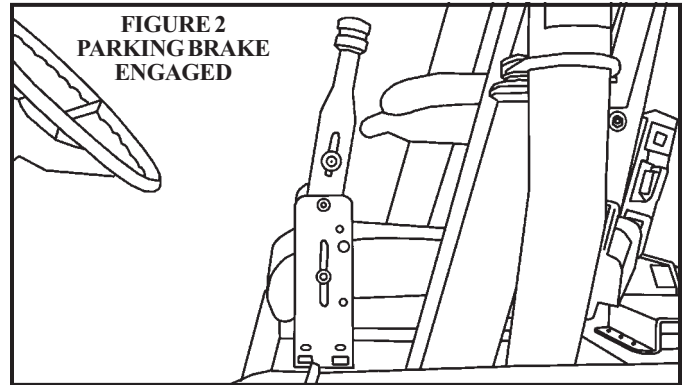

FIGURE 2
PARKING BRAKE
ENGAGED

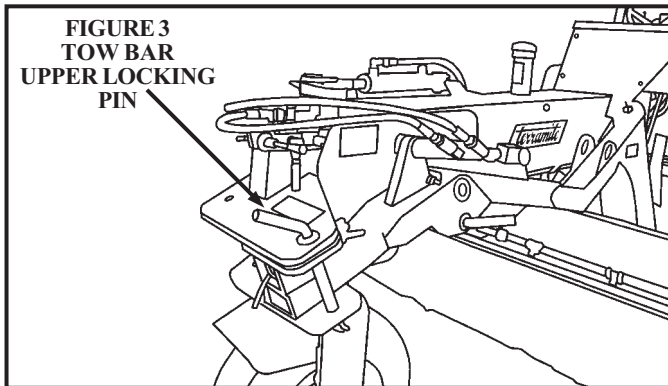

FIGURE 3
TOW BAR
UPPER LOCKING
PIN

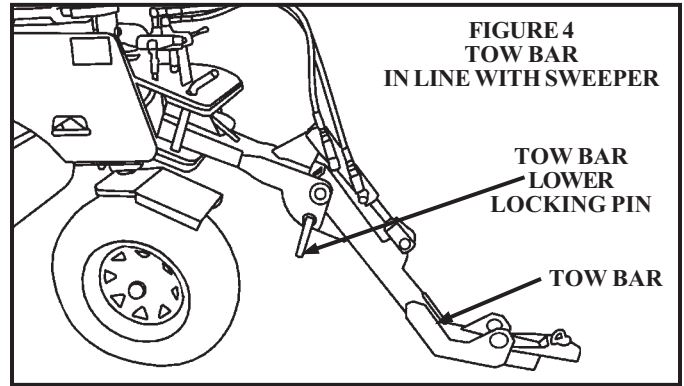

FIGURE 4
TOW BAR
IN LINE WITH SWEEPER

TOW BAR
LOWER
LOCKING PIN

TOW BAR

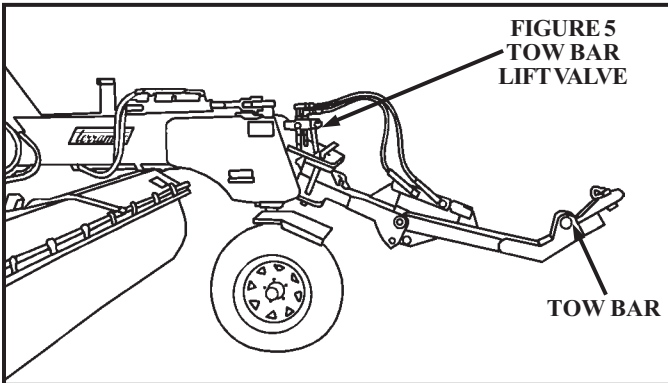

FIGURE 5
TOW BAR
LIFT VALVE

TOW BAR

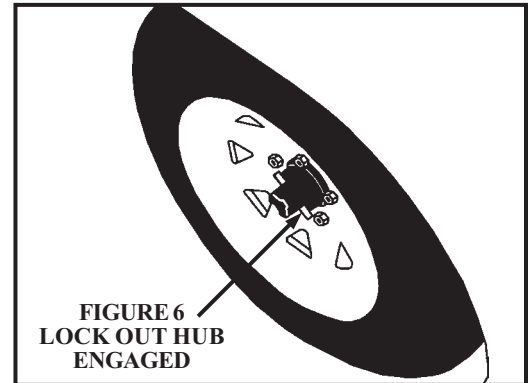

FIGURE 6
LOCK OUT HUB
ENGAGED

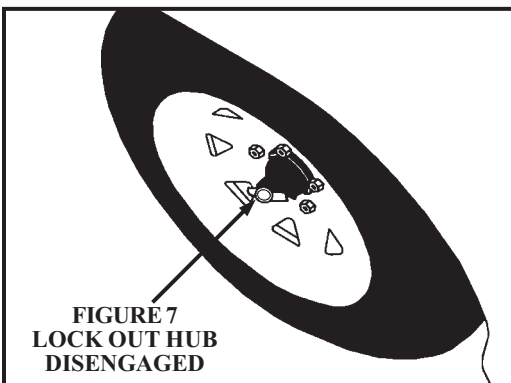

FIGURE 7
LOCK OUT HUB
DISENGAGED

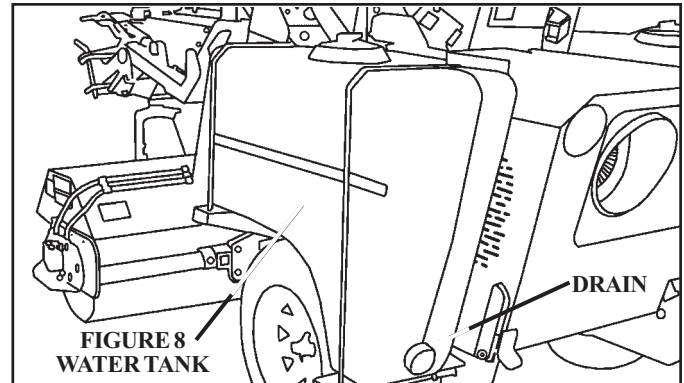

FIGURE 8
WATER TANK

DRAIN

Storing the Street Sweeper

For Storage of More than 30 Days

To insure maximum performance and minimum deterioration, the following procedures should be performed when the Terramite Street Sweeper will be idle for more than 30 days:

1. Wash the Terramite Street Sweeper and let dry (waxing will help prevent paint oxidation).
2. Change engine oil.
3. Charge battery fully and disconnect the battery leads.
4. Fill fuel tank within 2 inches of filler neck (keeps out condensation) and add fuel conditioner.
5. Squirt a small amount of oil into cylinders and crank the engine over a few times.
6. Grease all pivot pins. Liberally apply cup grease to all bare metal surfaces such as buckets and exposed cylinder rods. Grease all pivot pins. Retract all cylinder rods. Use WD40 on all electrical parts and areas inaccessible to regular grease.
7. Set the Terramite Street Sweeper on stands so the tires are off the ground. (Keeps tires from developing flat spots.)
8. Deflate tires to 1/2 pressure to relax cords.
9. Use a protective such as Armor All® on hoses, seat and tires to keep them from weathering
10. If the Terramite Street Sweeper is to be stored outside, cover with a tarp or plastic cover to minimize weathering.

Engine Operating Instructions

NOTE: With your Terramite Street Sweeper you will receive an Operation and Service Folder for the particular engine supplied with your machine. This manual contains detailed information as to operation, maintenance and repair of the engine and its various components. However, before attempting any major repair of the engine, contact your dealer or the factory as to whether it will affect your factory warranty.



Before starting make sure that nobody is standing in the immediate vicinity of the engine or driven machine.

1. ENGAGE PARKING BRAKE
2. CHECK THAT MACHINE IS IN NEUTRAL
3. CHECK THAT BROOM ROTATION IS IN OFF POSITION



Engine Fuel

WARNING! Diesel fuel, although less explosive than gasoline, is highly flammable, and its vapors can explode under certain conditions. Store diesel fuel only in approved containers in unoccupied buildings and away from sparks or flames. Do not add diesel fuel while the engine is hot or running, or start the engine near spilled fuel.



WARNING!

Do not activate the starter for more than 20 seconds. If the engine does not catch, wait one minute then try again.



WARNING!

If engine does not start after 2 attempts, refer to operation manual supplied with the machine or call Terramite Service Technicians for assistance.

Starting Kubota and Deutz Engines

1. Place key in ignition
2. Turn key clock wise to start position.
4. Release Key as soon as engine fires.



WARNING!

Do not activate the starter for more than 20 seconds. If the engine does not catch wait one minute then try again.



WARNING!

If engine does not start after 2 attempts, refer to operation manual supplied with the machine or call Terramite Service Technicians for assistance

Service Operations

Engine Operating Instructions (continued)

Do Not Use Ether as a Starting Aid

The engine has a high compression ratio, and using ether will ruin your engine. **The damage will not be covered under your warranty.**

Total Failure of Starter

If the starter does not turn the engine over, shut off the starter immediately. Do not make further attempts to start the engine until the condition is corrected.



CAUTION!

Do not crank the engine continuously for more than 20 seconds at a time. If the engine does not start, allow a two minute cool-down period between starting attempts. Failure to follow these guidelines will burn out the starter motor.



CAUTION!

If the engine develops sufficient speed to disengage the starter but does not keep running (a “false start”), the engine rotation must be allowed to come to a complete stop before attempting to restart the engine, or engine damage may result.



WARNING!

Do not tamper with the governor setting to increase the maximum engine speed. Over-speeding is hazardous and will void the warranty.



WARNING! Do not use JP4 Fuel or Ether

The minimum centane number 45 (Aviation fuel) JP4 or ether starting fluids must not be used.

Weather Considerations

Diesel Operation in Hot Weather

Operating the diesel engine in hot weather is mostly a matter of keeping the coolant at the correct level, the radiator clean and keeping an eye on the fan belt. Also, be certain of the viscosity of lubricants.

Temperatures Below 32 Degrees

There are several precautions which must be followed when the temperature drops below 32 degrees Fahrenheit. The oil in the engine and the hydraulic system needs to be changed to winter weight and a new oil and air filter should be considered. The battery should be kept at full charge. As starting may be more difficult, be sure that you do not run starter more than 20 seconds, followed by a two minute cooling off period. Do not hit the outside of the casing of the starter, as you may break the ceramic magnets.

Fuel Conditioner For Diesel Engines

Diesel fuel gets waxy at low temperatures and may not flow through the filter and pump at the normal rate of flow. Therefore, a good fuel conditioner additive is highly recommended for temperatures below 32 degrees Fahrenheit.

Below 10 Degrees

Special procedures must be followed so your machine may be readily started without damage. The hydraulic system and the engine need to be fitted with electric heaters. The machine can be warmed with a high output forced air heater.

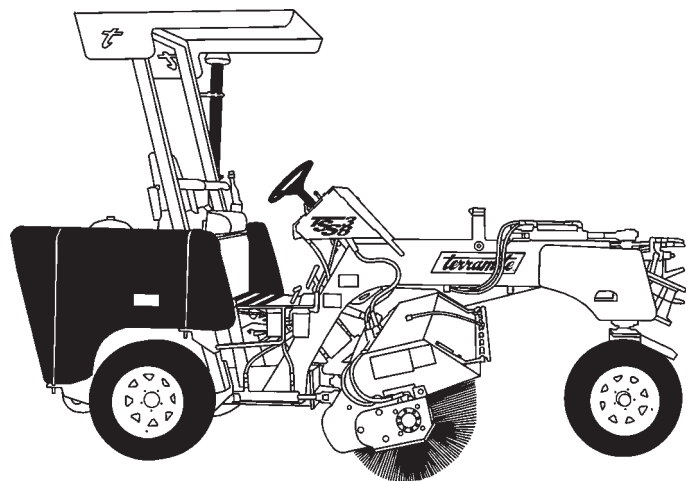

Periodic Service

General Considerations

These required maintenance procedures should be performed at the frequency stated in the table. They should also be included as part of any seasonal tune-up. Perform these maintenance procedures more frequently when the engine is operated under extremely dusty or dirty conditions. Although your Terramite Street Sweeper is made of the finest and most durable materials, it will only hold up if given proper care. The maintenance procedures are very simple and easy to do. We have also included space in the back of this handbook for keeping a service record of your machine.

IMPORTANT: See attached *New Machine First Service Schedule* for items that should be checked or serviced during the first 4 to 50 hours.

REQUIRED MAINTENANCE	FREQUENCY
Clean Air Intake Screen	Daily
Check Engine Oil Level	Daily
Check Hydraulic Oil Level	Daily
Check/Replace Fuel Filter**	As Required
Change Oil and Filter	As Specified
Clean Cooling Fins and External Surfaces	50 hrs. or as required

****SEE ENGINE MAINTENANCE MANUAL**

We also suggest that the air filter be checked weekly in the event you are working in extremely dirty or dusty conditions. The manufacturer's air filter should be used, or warranty may be denied. Otherwise, check and clean monthly.

Engine Oil Service

Engine Oil (Recommended)

Refer to engine operating manual supplied with machine.

Checking Engine Oil

Before checking the oil, make sure the engine is stopped and resting on a level surface. Also, make sure the engine is cool and the oil has had time to drain into the sump. Bring the level up to, but not over, the full mark on the dip stick. Always check the level before adding more oil.

CAUTION: Do not operate the engine above or below marked area on the dip stick.

Changing Engine Oil

For a new engine, change oil after the first 5 hours of operation, after that every 100 hours (50 if multi-viscosity oil is used). Drain oil while the engine is warm from operation. The oil will flow freely and carry away more impurities. Drain oil as follows: Remove the oil drain plug and oil fill cap. Dispose of the oil in a manner that meets Local, State and Federal regulations. Reinstall the drain plug. Make sure it is tightened securely. Be sure the engine is level when filling and checking oil. Then fill with new oil to the top line on the dipstick. Refer to engine operating manual for proper type. Always check the level on the dipstick before adding more oil. Reinstalled the oil fill cap and make sure it is tightened securely.

Changing the Engine Oil Filter

Your Diesel is equipped with an oil filter. Replace the oil filter, in accordance with the "Oil Change Intervals" table. Always use a genuine OEM oil filter and replace as follows: Drain crankcase oil, then remove old filter. Before installing replacement filter, apply a thin coating of clean oil on the surface of the rubber seal. Turn filter clockwise until rubber seal contacts the filter adapter, then tighten filter an additional 2/3 to 3/4 turn. Add an additional 1/2 pint of oil for the filter capacity. Start the engine and check for oil leakage.

Extended Engine Oil Change Intervals

NOTICE: Using other than the proper class oil or extending oil change intervals longer than recommended will cause engine damage which is **not covered by the engine warranty.**

Engine Air Filter (Paper Element)

The diesel engines are equipped with a high-density paper air cleaner element. The paper element should be replaced every 100 hours. Do not wash or use pressurized air to clean the paper element. Before installing new filter, be sure to inspect it for damage and that it fits perfectly when replaced.

Service Operations

Hydraulic System Service

Check Hydraulic Oil Level Daily

Before checking the hydraulic oil sight gauge, all cylinders should be retracted. The correct oil level is halfway up the sight gauge. To avoid damage to the hydraulic pumps, drain and replace milky-looking oil. Proceed as follows to drain the oil out of the reservoir tank.

Hydraulic Oil Filter

When the machine is new, the system oil and filter should be changed within the first 50 hours. After that, every 200 hours. Fill system with API SF/CD 10W below 40 degrees. Oil should be changed on a level surface. It is recommended that the oil be changed right after use while the oil is warm.

Hydraulic Oil Leaks Can Be Dangerous

WARNING! As this may be your first experience with a machine that functions primarily through hydraulic pressure, never inspect or put your hands close to any part of the hydraulic components of the machine while the engine is running or within two minutes after being shut down. If injured by escaping fluid, go to the emergency room of the nearest hospital at once and tell them the nature of the injury. If there is not a hospital in the vicinity, call a physician. Serious infection or a reaction such as gangrene can develop if proper medical treatment is not administered immediately.

Minor Hydraulic Oil Leaks

Oil leaks are often difficult to locate, as oil may leak from areas in the machine that are hidden from view. However, if you can locate the leak, take a cloth and completely dry everything around the leak to determine how fast the oil is escaping. A drop of oil every 10 seconds is only 1/2 oz. per hour. Do not use teflon tape to try to stop a leak, as it can get loose in the system. You can easily over tighten a fitting or hose wrapped with teflon, causing a housing to crack. The preferred sealant is Loktite™ hydraulic thread sealant with teflon paste.

DANGER! Oil and Fittings Get Hot

It is normal for the hydraulic oil to reach 170 degrees; and the hydraulic hoses, cylinders and components, acting as a large passive radiator, can reach temperatures of over 200

degrees. However, if the surface or hydraulic oil temperatures exceed these temperatures, it may be caused by having a control valve held open too long. Always return control valve to neutral when not in use. It could also indicate a low oil supply or contaminated oil. If low, refill. If contaminated, drain and refill with new oil, and replace filter. It could also indicate a kink or dent in a hose line or a worn pump. (See Service Manual for Pump replacement.)

NOTE: Always make sure major leaks are contained and the oil disposed of in a proper manner. Stains on concrete may be removed by applying a mixture of oil dry and solvent. Let mixture set for a few hours before removal. Dispose of according to applicable Local/State/Federal Laws.

Changing the Hydraulic System Oil

1. Make sure all the cylinder rods are fully retracted.
2. Remove the sump line.
3. Remove the sump strainer, wash it in solvent, dry thoroughly.
4. Replace in reverse order.
5. Fill the system with recommended oil until it reaches the proper level.

NOTE: There is no need to bleed the hydraulic system, the air will come out of the oil by itself. The machine may vibrate for a few minutes until the air purges. Be sure to dispose of your waste oil in a manner acceptable to Federal, State and local authorities.

Some Tips on Hydraulic Hoses

Inspect hoses regularly for nicks, cuts and wear. There are two wire braid layers under the rubber outer cover. When wire is exposed but undamaged, the hose still may be used, but should be replaced as soon as possible.

If You Need New Hydraulic Hoses or Parts

All hoses are JIC. Hoses may be obtained from Terramite Corporation or any industrial rubber supplier or hydraulic shop. Return the old hoses so they can match them. Short hoses may be made from the good portion of a damaged hose.

Street Sweeper Lubrication

Lubricating the Pivot Pins

The most important single thing you can do to increase the life of the Terramite Street Sweeper is proper lubrication of the pivot pins. The pivot pins should be lubricated with a good lithium based grease every **four hours** of operation. Wipe dirt from the fittings before greasing. Replace any lost or damaged fittings immediately.

How to Ruin a Good Machine

The first 20 hours of use are critical to the life of the machine. The pivot pins have minute edges which need to be broken in just as an automobile engines need to be broken in. If the pins are not adequately greased, they will break their retainers and work out, possibly causing damage

to your machine. An ungreased pin will rust. The next time you use the machine the rust wears off, exposing more metal, which also rusts. The rust and dirt make a destructive grinding compound. Many people falsely blame the manufacturer for their own neglect in lubricating the machine. This is not covered under your warranty.



Use Caution when Replacing Pins

When driving pivot pins in or out, use care to guard against injury from particles that may chip off the pin or object used in striking the pin. These pins can fly out at considerable speed if they are not tapped lightly just before they come out. Safety glasses must be worn.

Battery and Tires

Low Maintenance Battery

Your Terramite Street Sweeper is equipped with a low maintenance battery. It uses a special construction to minimize water requirements. There is an “eye” on the battery to determine the conditions.

Cold Weather Considerations

NOTE: Cold weather makes a marginal battery useless. A battery fully charged at 80 deg. F. will have only 60% of its capacity at 32 deg. F., and only 40% at zero. A half-charged battery has only 32% at 32 deg. F and 21% at zero.

Tire Pressures and Rim Size

Titan - ST Radial 205/75R14
50PSI Cold -Load 1760 Lbs.



Avoid High Tire Pressure

CAUTION! Excessive tire pressures increase the possibility of punctures and cause a rougher ride. The rim or tire could blow out, causing extreme injury or even death!

Tire Traction and Hazards

Avoid excessive wheel spin when loading. On most surfaces, wheel spin causes loss of traction and premature wear out of tires. Watch for hazards such as nails, glass, etc.

Paint and Cleaning

Protecting the Paint

Because it is highly resistant to nearly everything, it requires little care. But constant exposure to sunlight will fade it just as other paints eventually fade. A coat of wax will help protect it. Leaving spilled diesel on your hood is not only an unsafe practice, but will cause stains and will

inevitably eat through your paint. Small scratches should be touched up or kept waxed to keep rust from attaching the metal under the paint.

Service Operations

Paint and Cleaning (continued)

Paint Cleaning Solutions

Some cleaning solutions and solvents used in high pressure washers may bleach the finish if used in high concentration or not rinsed from the machine. This can be avoided by diluting the cleaning solution or not letting it set too long.

Fasteners (Nuts and Bolts)

It is particularly important to check all nuts and bolts for tightness after the first 5 hours of use. All drive train bolts should receive extra attention. Thereafter, check every 250 hours.

Trouble Shooting

If a particular difficulty is experienced, check the symptoms listed below. Possible causes and remedies are given for each symptom. If the trouble is not corrected after following the suggested solution, call your dealer or call Terramite Corporation.

Total Failure of Hydraulic Power

(Engine is running, but nothing works)

Stripped engine to transmission coupling. Must be replaced.

Loss of Tram Power

The hubs may be disengaged for towing. This will cause loss of tram power.

This may indicate a worn transmission. Check with factory technician

Loss of Sweeping Power

Check for:

1. Low hydraulic oil.
2. Collapsed hose (hose can collapse internally, not showing any visible signs.)
3. Worn Pump. Check pump pressure.
4. Internal Valve leakage. Valves will sometimes develop leaks between the spools, yet not leak outside. Switching hoses to another valve will determine whether the valve section is bad.
5. Broken or weak relief valve. Check pressure. Check for fatigued or broken relief valve spring. All cylinders will lack power. You will have a little more power when your machine is cold. A weakened spring will lose power so gradually that you may not notice the decline in power until it seriously affects the machine performance. A broken spring will cause a sudden drop in cylinder power.

Sluggish and Slow Operation

Oil still cold. Pump badly worn or damaged. Restriction in suction line. Clogged oil filter or sump strainer.

Control Valve Sticks or Works Hard

Normally, this is a problem for your dealer's service department. It is usually dirty valves, tie bolts too tight or float detent position adjusted too tight.

Street Sweeper Doesn't Move in Either Direction

If this happened over a period of time, the transmission is totally worn out. If it happened instantly, check for the following:

1. Make sure rear lock-outs are in.
2. Foot pedal disconnected.
3. Bolts broken on coupling.

Transmission/Pump Makes Noise

First check the oil viscosity. If too high, replace with specified oil. Then look for a kink or dent in oil lines. If not of these, it may be air in the system. See your dealer.

Erratic Motion

1. Retract all rods and check hydraulic oil level.
2. Broken or weak pedal spring.
3. Worn transmission.

Hydraulic Oil Foams

1. Low oil supply.
2. Air leak in line from reservoir to pump.
3. Incorrect hydraulic oil.
4. Blocked valve restrictor.
5. Check sump hose for tightness.

Trouble Shooting (continued)

Hydraulic Oil Heats

1. Low oil supply.
2. Contaminated oil.
3. Control valve held open too long.

None of the Problems Listed

If the problem involves a part of the machine, such as the engine, transmission, hydraulic pump, etc., that is manufactured by someone other than Terramite Corporation, first check your service manual for more detailed information. If you do not find it there, contact your dealer or the original manufacturer's service department. For dealer locations, call Terramite Corporation at 1-800-428-3772 or International 1-304-776-4231.

Wheel Drive Slow or Will Not Go

1. Drive motor seal failure may be checked by removing the plug on the rear wheel lock out. If there is any oil present the motor shaft seal has failed.
2. Check hydraulic pressure of transmission.

Broom Rotation Stops or is Slow

1. Check Gear pump pressure using a portable hydraulic test box, test the GPM and PSI with the engine RPM

at full throttle, the Gear Pump should produce from 9-1/2 to 10-1/2 GPM at 3,000 PSI.

2. To check broom motors individually, disconnect the 2 hoses to the motor and plug the hoses with steel caps. Install a jumper hose between the ports to eliminate leakage.
3. If the broom motor is not able to run the broom, remove the broom motor and make sure the square key on the broom motor shaft has not sheared.

Setting the Auxiliary Hydraulic System Main Relief Valve

1. Install a 5,000 lb. pressure oil filled gauge in the outlet port of the relief valve.
2. Start the engine and set the throttle at full. Slowly turn the adjustment screw in (turn clockwise) until a consistent pressure of 3,000 PSI is reached. Lock down the lock nut and install the acorn cap on the screw and recheck the pressure.

Main Pump Output Testing

Use a hydraulic pressure gauge and a flow meter that measures both flow (GPM) and pressure (PSI). The transmission pump will produce 15 GPM and approximately 3,500 PSI with the engine set at full throttle.

Machine Operation Control Location

Purpose and Scope

ITEM	LOCATION	FUNCTION
1. Seat Belt	Left and right side of seat.	To prevent operator from falling off machine.
2. Parking/Emergency Brake	Lever to left of seat.	To hold machine from rolling when parked and in neutral. To be used for emergency stopping of machine.
3. Variable Speed	Forward and to the right of the right foot position on the floorboard	Varies machine speed in forward and reverse when F/R Valve handle is actuated.
4. F/R Valve Lever	Located to the right of the operator seat.	A. Forward position allows machine to travel forward when variable speed pedal is depressed (See Item 4). B. Center position hydrostatically locks machine in park (be sure to also set Parking Brake).

Service Operations

Machine Operation Control Location (continued)

ITEM	LOCATION	FUNCTION
		C. Rear position allows unit to travel in reverse when the variable speed pedal is depressed (See Item 4).
5. Keyswitch	Centrally located below the steering wheel.	Preheats engine glow plugs when turned and held in full left position, starts engine when turned and held in full right position. 1st "Notch" positions from full right is "Run", and 2nd "Notch" position from full right is "Off". (On Kubota ONLY)
6. Broom Rotary	Located to the right of the steering wheel.	When pushed forward broom sweeps forward, when in center position, broom stops. Variable speed rotation.
7. Broom Left-To-Right	Located to left of and furthest from the steering wheel.	When pushed forward, right end of broom moves towards rear when pulled back, right end of broom moves forward.
8. Broom Lift Control	Located to left of and closest to the steering wheel.	When pushed all the way forward and locked into detented position, broom head goes to lowered and operating float position. When lever is pushed forward broom head raises off of surface.
9. Engine Throttle	To right of and below the steering wheel.	To set engine operating speed.

Lubrication and Maintenance Chart

ITEM	DESCRIPTION/LOCATION	MAINTENANCE SCHEDULE
1. Grease Fittings	<ul style="list-style-type: none"> a. (2) Bearing on Front Fork b. (1) Variable-Speed-Pedal under floorboard c. (2) Left and Right on Brake Rod d. (1) Foot Brake 	Grease all fittings daily
2. Hydraulic Oil	With oil hot, oil level should be in center of eye on side of hydraulic tank and/or 1" below top of tank. Capacity: 20 Gallons	Change Hydraulic Oil every 6 months or as needed.
3. Hydraulic Spin-On Filters	<ul style="list-style-type: none"> a. 10 Micron Part #21002 2 under floorboard. b. Hydraulic Tank Screen Part #38072 at rear of Hydraulic Tank. c. High Pressure Filter Element Part #38019 inside hood and to right of engine. 	Change both Spin-On filters every 3 months. Remove and clean every 6 months. Change every 6 months.

Lubrication and Maintenance Chart (continued)

ITEM	DESCRIPTION/LOCATION	MAINTENANCE SCHEDULE
4. Engine Oil	Engine Oil Type: Refer to Engine Manufacturers Operations Manual.	Change Engine oil and all filters, air, spin-on fuel, in-line fuel, and oil every 150 hours.
5. Radiator Water/Anti-freeze	Strictly 50% water and 50% permanent Antifreeze mixture only!!!!	Check mix and level. Level to be 1/2 full in plastic over-fill tank.
6. Tire Pressure	45 PSI to 50 PSI	Check Daily.
7. Water Filters	Under Floorboard, Water Tanks	Clean as Needed
8. Front Wheel Bearings	Front Wheel inside and outside.	Repack monthly.
9. Fuel Tank Drain	Pipe plug located in center of and at bottom of fuel tank.	Drain once a year.
10. Wheel Lock-Out Oil Level	Between wheel and frame. Remove female hex plug on front or back of housing to check. Capacity: 6 Ounces Motor Oil: SW 30 Wt. Detergent	Check every 3 months.

Service and Maintenance Points

All references to "Left" or "Right" side of the Terramite Street Sweeper are stated as from the Operators seat facing forward.

Anti-Freeze Mix

Liquid cooled engines are very sensitive to the water/antifreeze mix. Too much of either water or antifreeze will cause engine overheating. The proper mix is 50% water and 50% antifreeze.

Air cooled engines have no need for anti-freeze.

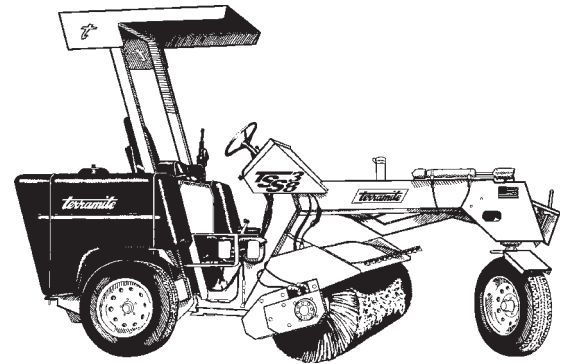

Machine Trouble Shooting & Hydraulic Component Check-Out

Before testing any hydraulic component always check the hydraulic oil level. Bring the hydraulic oil temperature up to 20° over Ambient. Place the machine on a flat surface.

The hydraulic oil level should be in center of the "Eye" indicator and/or not more than 1" below the top surface of hydraulic oil tank.

Service Operations

Proper Care and Use of Broom Wafers

Broom Storage

The broom portion of the Terramite Street Sweeper should be stored away from direct sunlight. Prolonged exposure to sunlight greatly reduces the life of the bristles.

Do not leave broom head lowered with weight on the bristles when not in use. Weight on the bristles for long periods of time will cause the bristles to become permanently deformed, resulting in lowered sweeping effectiveness.

1/2 Poly - 1/2 Wire Wafers (Standard)



1/2 Poly and 1/2 Wire Wafers are used for varying sweeping conditions. The 1/2 and 1/2 combination is used to sweep throughout the year without changing cores. This combination is the most used approach. Eight foot brooms require 24 poly and 23 wire wafers and six foot brooms require 19 poly and 18 wire wafers

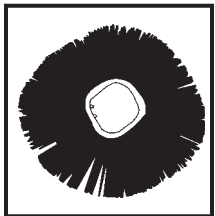

Poly Wafers

For normal sweeping operations, such as sand, dirt, paper, etc. This wafer will be the best for dry sweeping. Maximum 3" brush pattern.

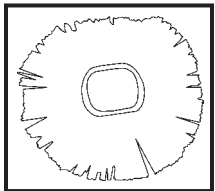

Wire Wafers

For hard material sweeping, such as concrete curing, mud, rock, snow, etc. This wafer is the strongest wafer available and with the sharpest cutting force. For snow usage the ends pierce

the snow and ice quicker than poly wafers. This quickness requires less down pressure.

Maximum 3" brush pattern. Exceeding this pattern will lead to wire breakage, excessive wire wear, and short life of the wafers.

Brush Wafer Wear Life

The brush is one of the most important parts of the sweeper and its operations. The brush is a replaceable component that literally performs the hard work.

EXAMPLE OF WEAR LIFE

Fine Asphalt	1 Year
Finish Coated Asphalt	6 Mos.
1st Pass Asphalt	3-4 Mons.
Milling (Ground up road surface)	1 week

These number will be greatly reduced if used in an incorrect manner.

Factors for Longer Brush Life.

- BROOM LEVEL**
A broom not level with the sweeping surface may cut wafer life in excess of 50%.
For maximum broom wafer life the level of the broom must be checked daily. The time spend in checking and correcting the broom level will pay in the extended life of the broom wafers.
- TURNING BROOM CORE**
Turning the broom core from end to end during the life of the brush will also extend its life. This turning helps prevent uneven wear caused by sweeping material from the same side, refer to page 2.17.
- BRUSH DOWN PRESSURE**
The most common reason for short brush life is too much down pressure. By using the proper amount you can obtain maximum brush life.
The best sweeping action occurs by the "flicking" action of the bristles at their tips. By applying too much down pressure the bristles are using their "sides", this action greatly accelerates wear and reduces sweeping efficiency.
To limit down pressure, Terramite Street Sweepers are equipped with an adjustable spring assembly. Proper adjustment is shown in Figure 1.
- PROPER GROUND SPEED**
Proper ground speed is important for the life of the brush. Running the machine too fast may allow material to accumulate in front of it. This build up of material creates pressure on the bristle "sides", which leads to their "wear".
For proper operation, sweep at high enough brush speed to discharge material and with proper ground speed to discharge the swept material from the sweepers path.

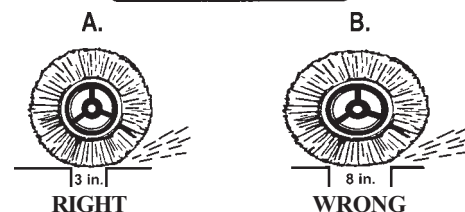

FIGURE 1
Brush Setting Decal and Proper Brush Setting

Broom Core Removal/Wafer Replacement

1. Place sweeper in level spot.
 2. Engage parking brake
 3. Turn off engine.
 4. Clean the broom head.
 5. Lower the sweeper head until the bristles just touch the surface.
 6. Remove the 3 bolts (Shown as "A" in Figure 1).
 7. Remove the bolt (Shown as "B" in Figure 1).
 8. Pull the motor assembly from the brush core and lay it to the side. **DO NOT REMOVE ANY HOSES!**
 9. Start the sweeper at low idle. Raise the broom head enough to allow the core to be completely removed. Turn off engine.
 10. If turning the broom for brush life, rotate broom core and skip to step. 16.
 11. Remove the (2) screws and cap plate (Shown as "A" in Figure 2).
 12. Remove wafers.
 13. Place a wafer onto the core with the drive pins between the tube (Shown in Figure 3 for proper placement and Figure 4 for improper placement).
 14. The next wafer is flipped as it is placed over the core and rotated 1/3 turn (Shown in Figure 4 for proper placement and Figure 5 for improper placement).
- NOTE: To have proper number of wafers it may be necessary to tap them with a heavy rubber hammer.**
- NOTE: For 1/2 wire and 1/2 poly place a poly wafer on each end.**
15. Reattach the end cap.
 16. Place broom core into broom head.
 17. Reattach the motor assembly.
 18. Check for proper operation.

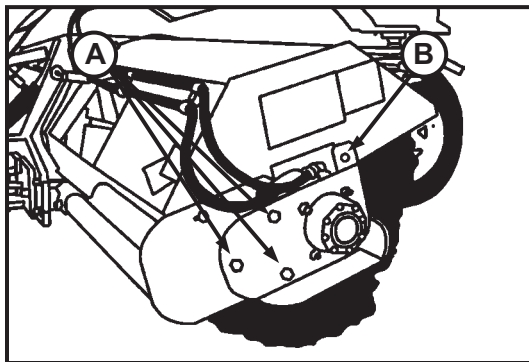

FIGURE 1

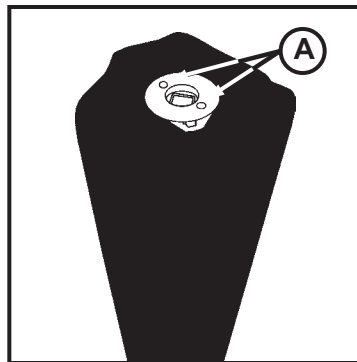

FIGURE 2

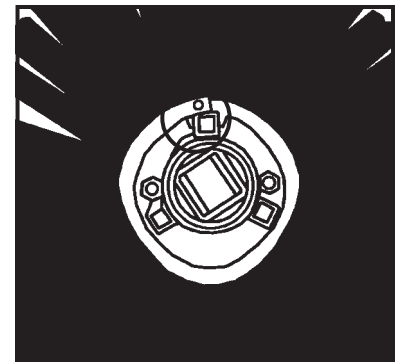

FIGURE 3
Proper Placement
of Drive Pins (Circled)



FIGURE 4
Improper Placement
of Drive Pins (Circled)

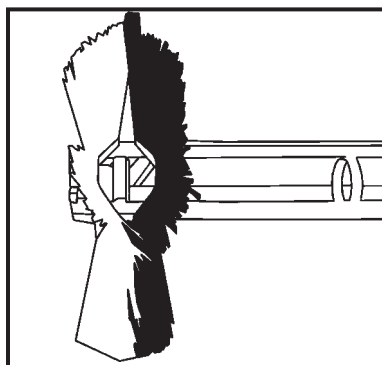

FIGURE 5
Proper Placement
of Wafers on Core

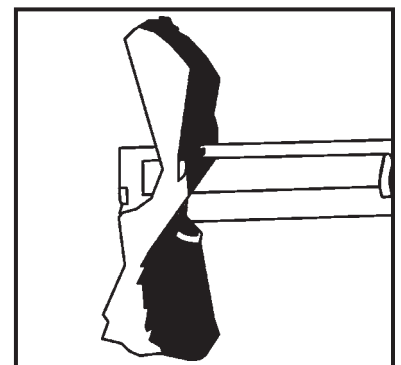

FIGURE 6
Improper Placement
of Wafers on Core

Service Operations

Setting and Adjusting Broom

1. Set the broom angle to that needed. (See Figures 1, 2 and 3).
2. Set broom level. (See Figure 4). Loosen the 3/4 lock nuts. (See Figure 5). Raise or lower broom motor to obtain consistant brush contact across full length of the broom.
3. Adjust broom contact. (See Figure 6).

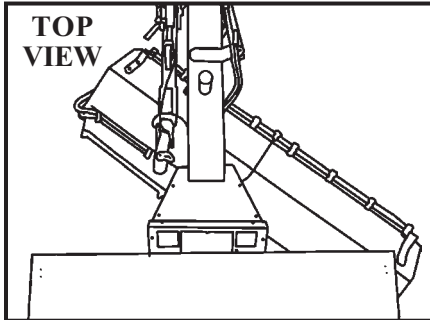

FIGURE 1
Angled Right

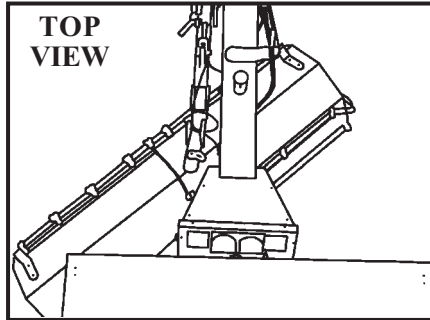

FIGURE 2
Angled Left

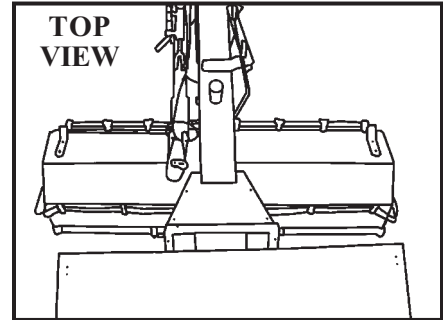

FIGURE 3
Straight

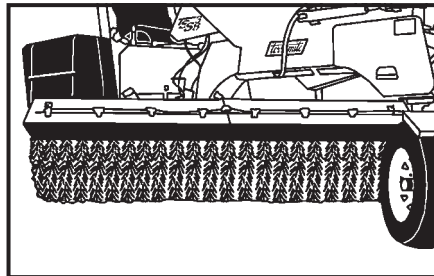

FIGURE 4
Horizontal Level

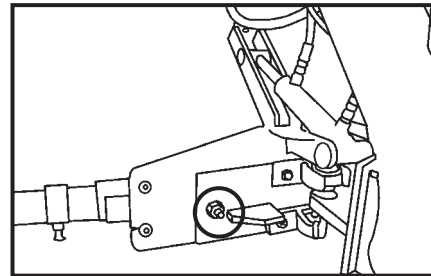

FIGURE 5
Lock Nut - Left Side (Circled)

BRUSH SETTING
SET BROOM DOWN PRESSURE TO MAINTAIN SWEEPING PATTERN WIDTH OF 3 INCHES MAX

⚠ WARNING ⚠

IMPROPER DOWN PRESSURE ADJUSTMENT CAUSES
• PREMATURE BRUSH WEAR OR DAMAGE
• POOR SWEEPING QUALITY

P/N 38195

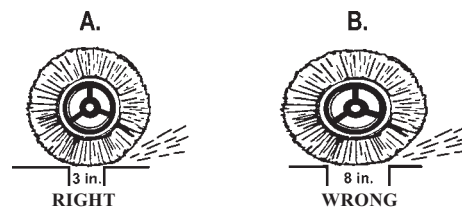
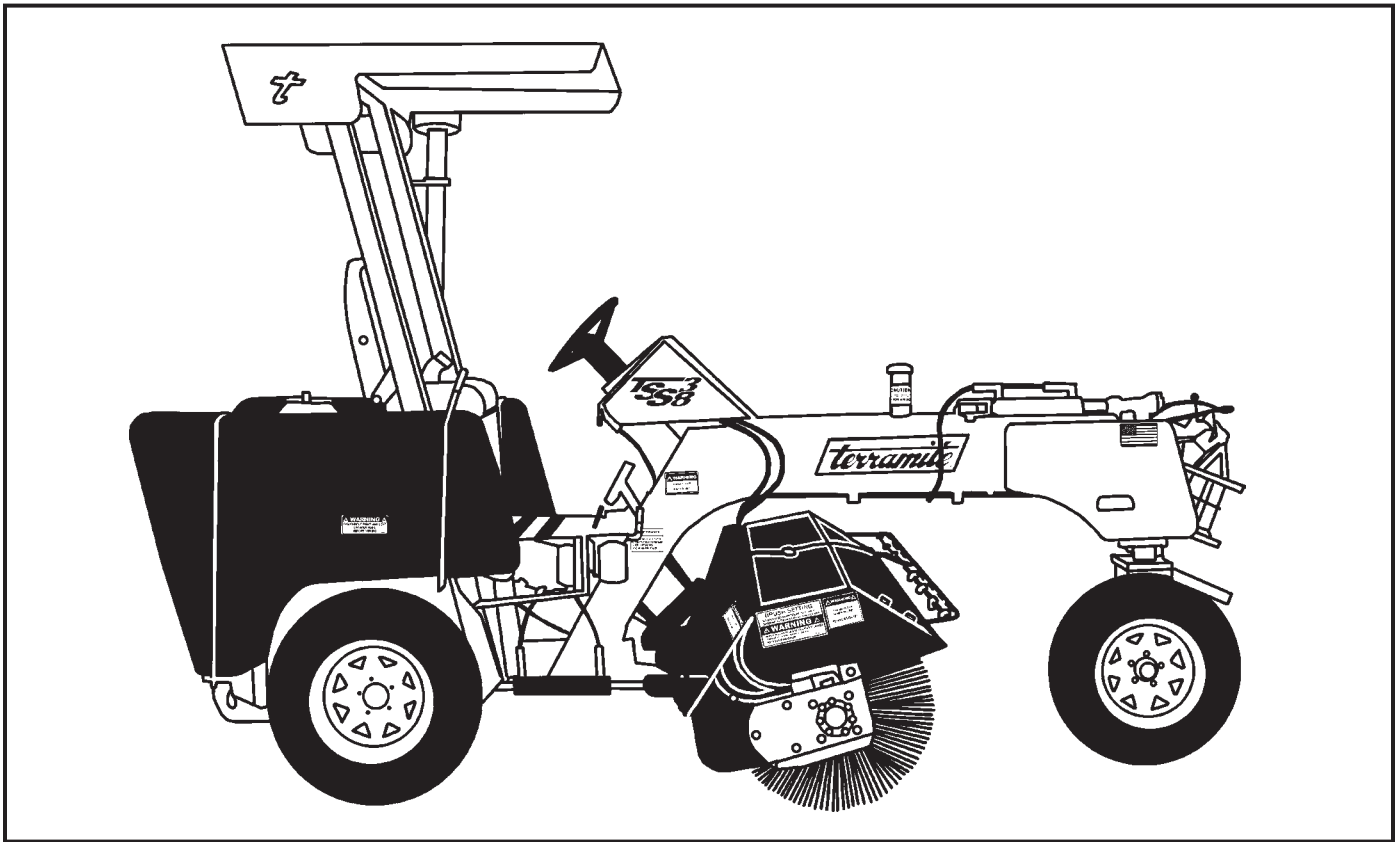
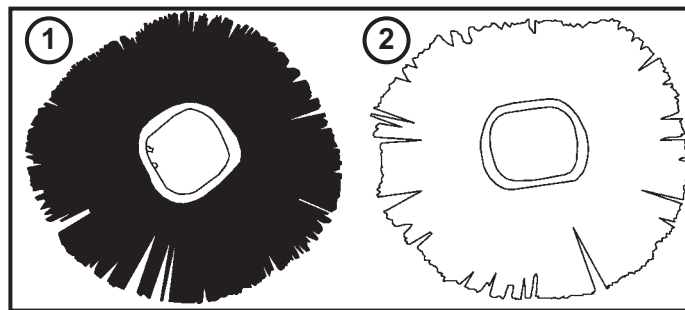

FIGURE 6 - Brush Setting Decal and Example of Proper Brush Setting

Please Note: Left or Right is Determined from the Operator's Position



Wafers



ITEM	PART NUMBER	DESCRIPTION	QTY.
1	38045	Wafer, Poly, Brush, Sweeper 8 Ft. 25 Poly 6 Ft. 20 Poly	N/A
2	38046	Wafer, Wire, Brush, Sweeper 8 Ft. 24 Wire 6 Ft. 19 Wire	N/A

Parts

View from Right Side of Operator's Position

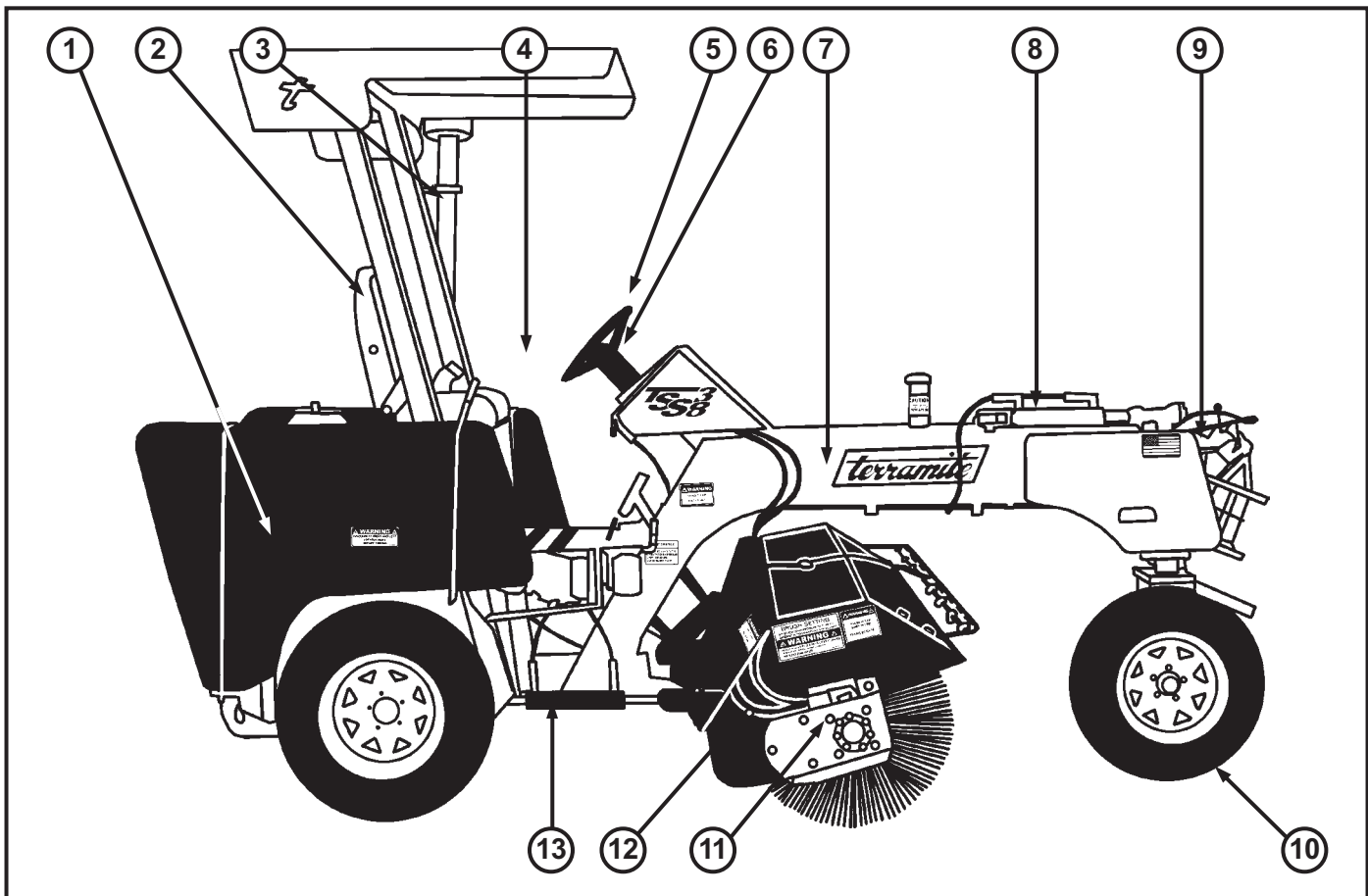

ITEM	PART NUMBER	DESCRIPTION	QTY.
1	38390	Tank, Water, Sweeper	2
2	14083	Seat, Sweeper/T5D/T7/T6/T9	1
3	38394	Pipe, Air Inlet, Deutz, Sweeper	1
4	38083	Handle, Brake, Sweeper	1
5	38061	Wheel, Steering, Sweeper	1
6	38537	Gear, Steering, Sweeper	1
7	38216	Frame, Sweeper	1
8	38015	Cylinder, Steering, Sweeper	1
9	38026	Valve, Tow Bar, Sweeper	1
10	38816	Assembly, Tire & Wheel, Sweeper	3
11	38052	Motor, Brush Core Drive, Sweeper 2	
12	38306	Bar, Brush Mount, Sweeper	6 Foot Broom Bar
	38307		8 Foot Broom Bar
13	38017	Cylinder, Brush Angle, Sweeper	1

View from Left Side of Operator's Position

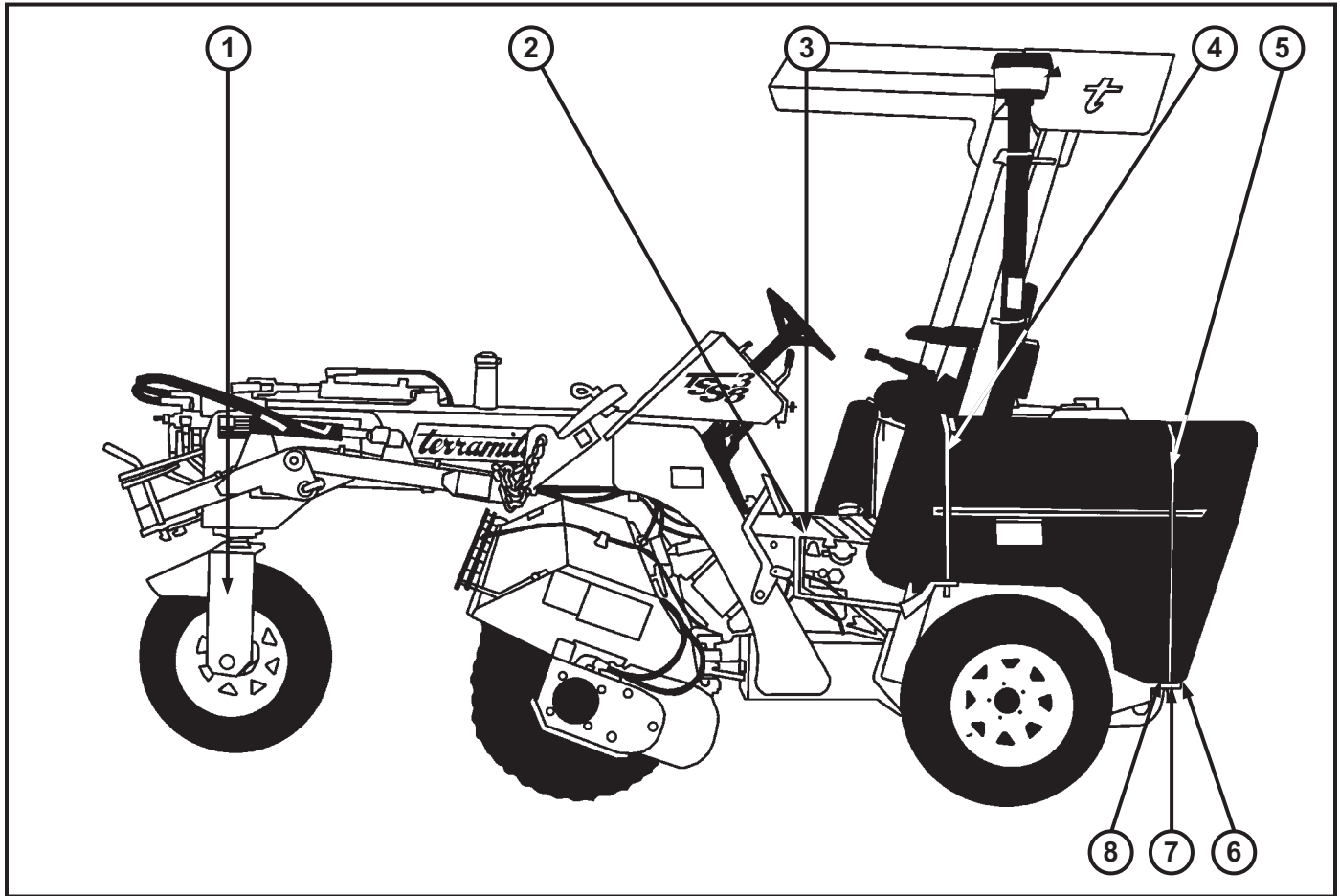

ITEM	PART NUMBER	DESCRIPTION	QTY.
1	38275	Fork, Front, Sweeper	1
2	38558	Bolt, Eye, Brake Extension Spring, Sweeper	1
3	38514	Spring, Brake Extension, ³ / ₄ OD, Sweeper	1
	38062	Pre-Cleaner Assy	1
4	38273	Strap, Front Holding, Water Tank, Sweeper	2
5	38272	Strap, Rear Holding, Water Tank, Sweeper	2
6	38440	Fitting, ¹ / ₂ MP x ³ / ₈ HB90, Water Tank, Sweeper	2
7	38637	Strainer, Drain, Water Tank, Sweeper	2
8	38580	Plug, Drain, Water Tank, Sweeper	2

Parts

View of Front with Tow Bar Extended

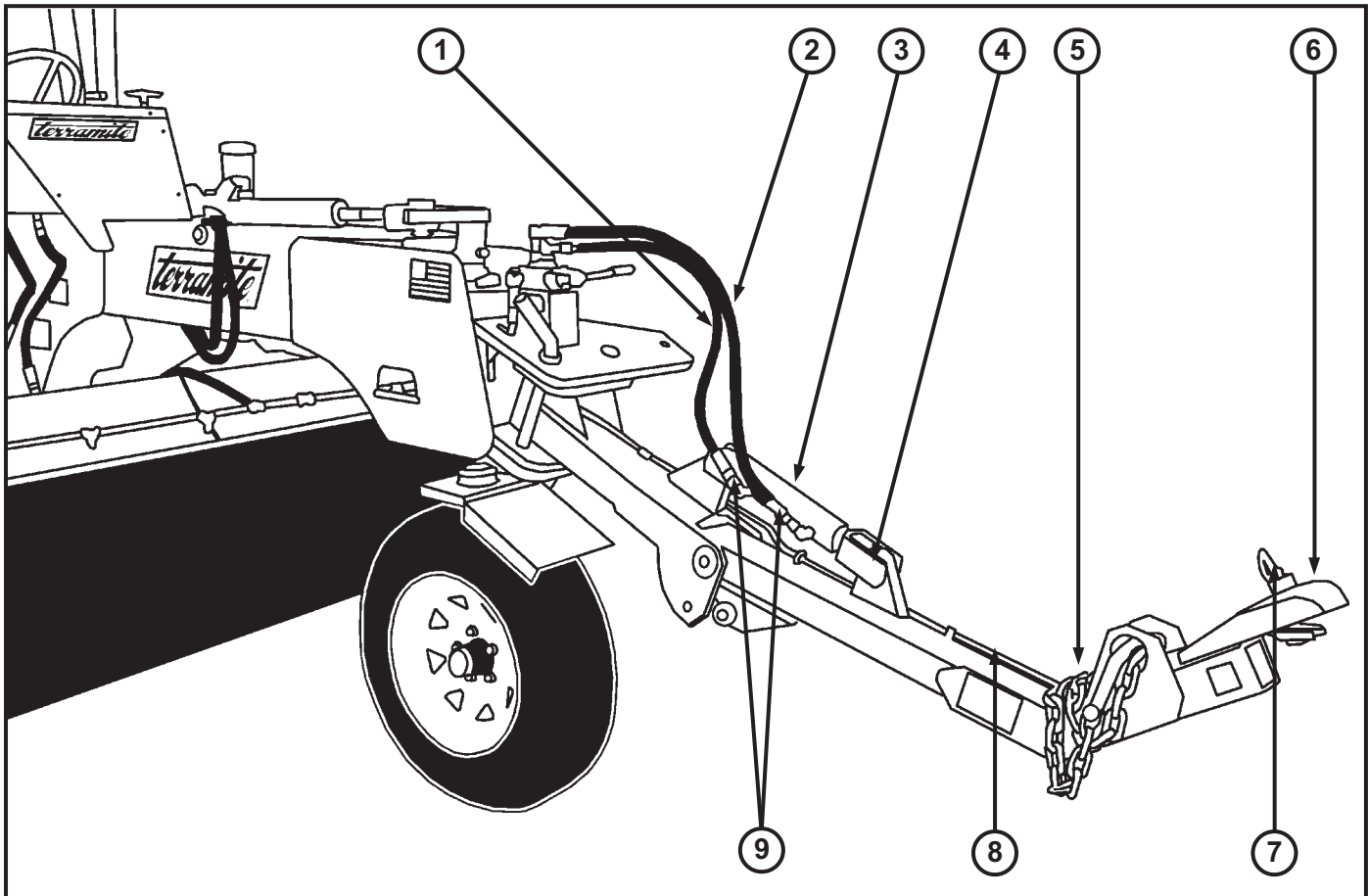

ITEM	PART NUMBER	DESCRIPTION	QTY.
1	38101	Hose, 3/8 x 31", #6FJIC Both, Cylinder, Tow Bar Lift, Sweeper	1
2	38106	Hose, 3/8 x 37", #6FJIC Both, Cylinder, Tow Bar Lift, Sweeper	1
3	38018	Cylinder, Tow-Bar Lift, Sweeper	1
4	38420	Pin, Tow-Bar Lift/Steering Cylinder, Sweeper	6
5	38489	Chain, Safety, Tow-Bar, Sweeper	4.5 ft.
6	38032	Coupler, Tow-Bar Hitch, 2", Sweeper	1
7	38622	Kit, Tow-Bar Coupler, Sweeper	1
8	38479	Harness, Electrical, Tow-Bar, Sweeper	1
9	38539	Fitting, #6 O-Ring x #6MJIC90W/.016, Cylinder Hose, Tow-Bar Lift, Sweeper	2

View of Tow Bar in Detail

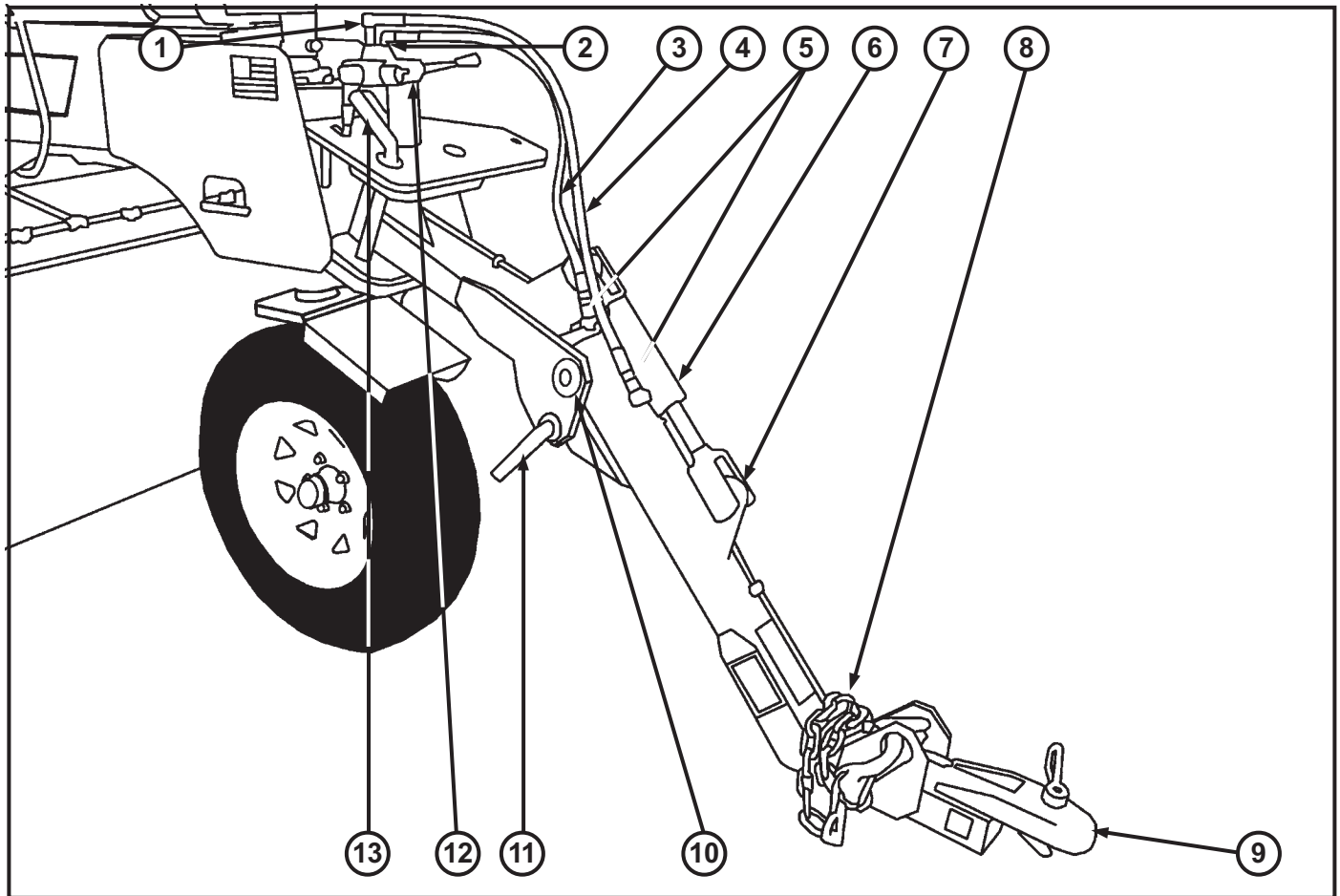

ITEM	PART NUMBER	DESCRIPTION	QTY.
1	20156	Fitting, #8 O-Ring x #6JIC90°, Tow-Bar Valve, Sweeper	1
2	20149	Fitting, #8MB O-Ring x #6JIC90°, Tow-Bar Valve, Sweeper	3
3	38101	Hose, 3/8 x 31", #6FJIC Both, Cylinder, Tow-Bar Lift, Sweeper	1
4	38106	Hose, 3/8 x 37", #6FJIC Both, Cylinder, Tow-Bar Lift, Sweeper	1
5	38539	Fitting, #6 O-Ring x #6MJIC90W/.016, Cylinder Hose, Tow-Bar Lift, Sweeper	2
6	38018	Cylinder, Tow-Bar Lift, Sweeper	1
7	38420	Pin, Tow-Bar Lift/Steering Cylinder, Sweeper	6
8	38489	Chain, Safety, Tow-Bar, Sweeper	4.5 Ft.
9	38032	Coupler, Tow-Bar Hitch, 2", Sweeper	1
10	38021	Pin, Tow-Bar, Sweeper	1
11	38023	Pin, Lower Locking, Tow-Bar, Sweeper	1
12	38026	Valve, Tow Bar, Sweeper	1
13	38042	Pin, Upper Locking, Tow-Bar, Sweeper	1

Parts

View of Lower Front

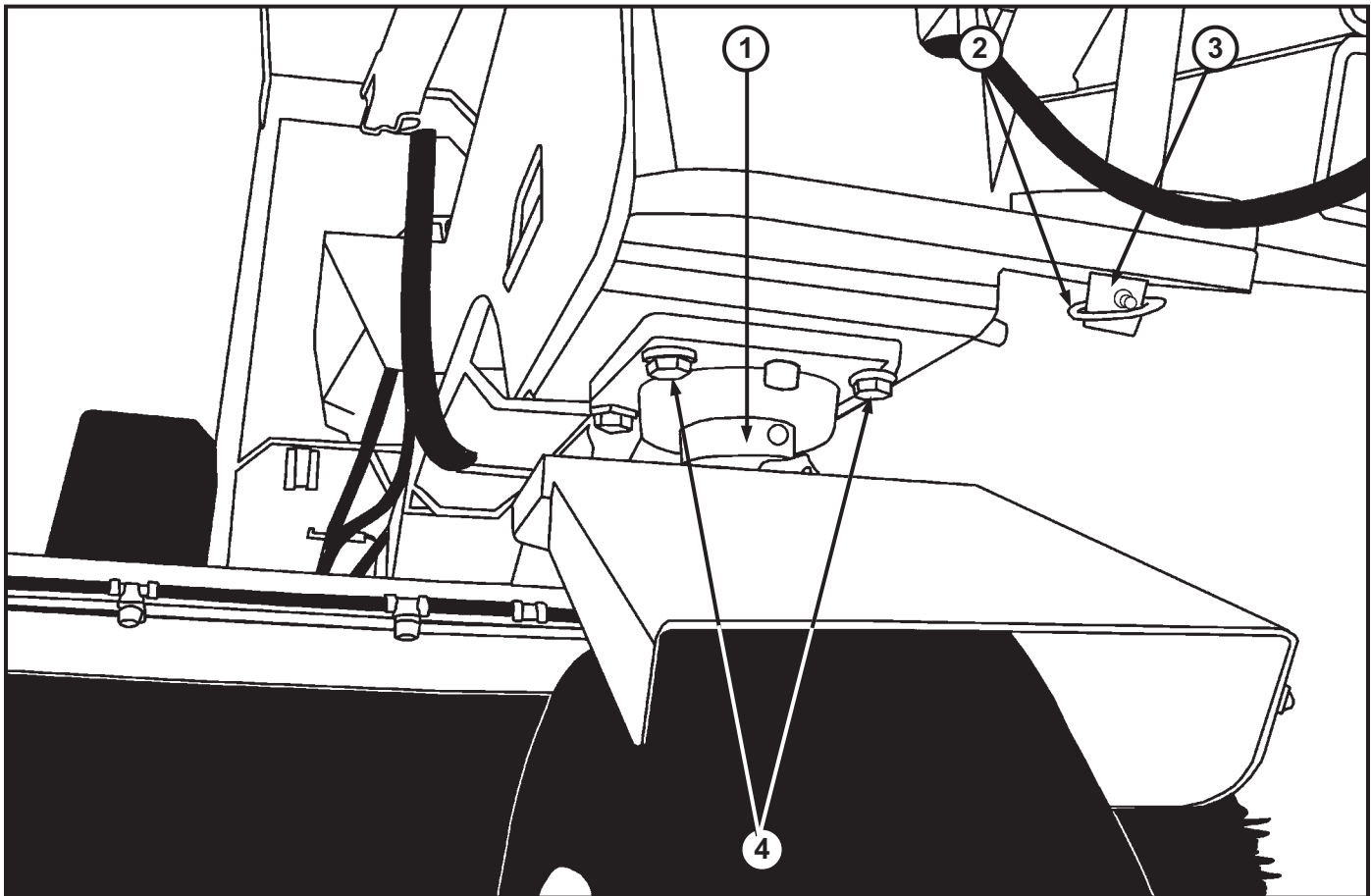

ITEM	PART NUMBER	DESCRIPTION	QTY.
1	38169	Bearing, 4 Bolt Flange, Front Fork, Sweeper	2
2	10202	Pin, Lynch, Tow-Bar Pivot Pin, Sweeper	4
3	38021	Pin, Tow-Bar, Sweeper	1
4	22160	Bolt, 5/8 x 2 1/4" GR8Z, Sweeper	8

View of Front

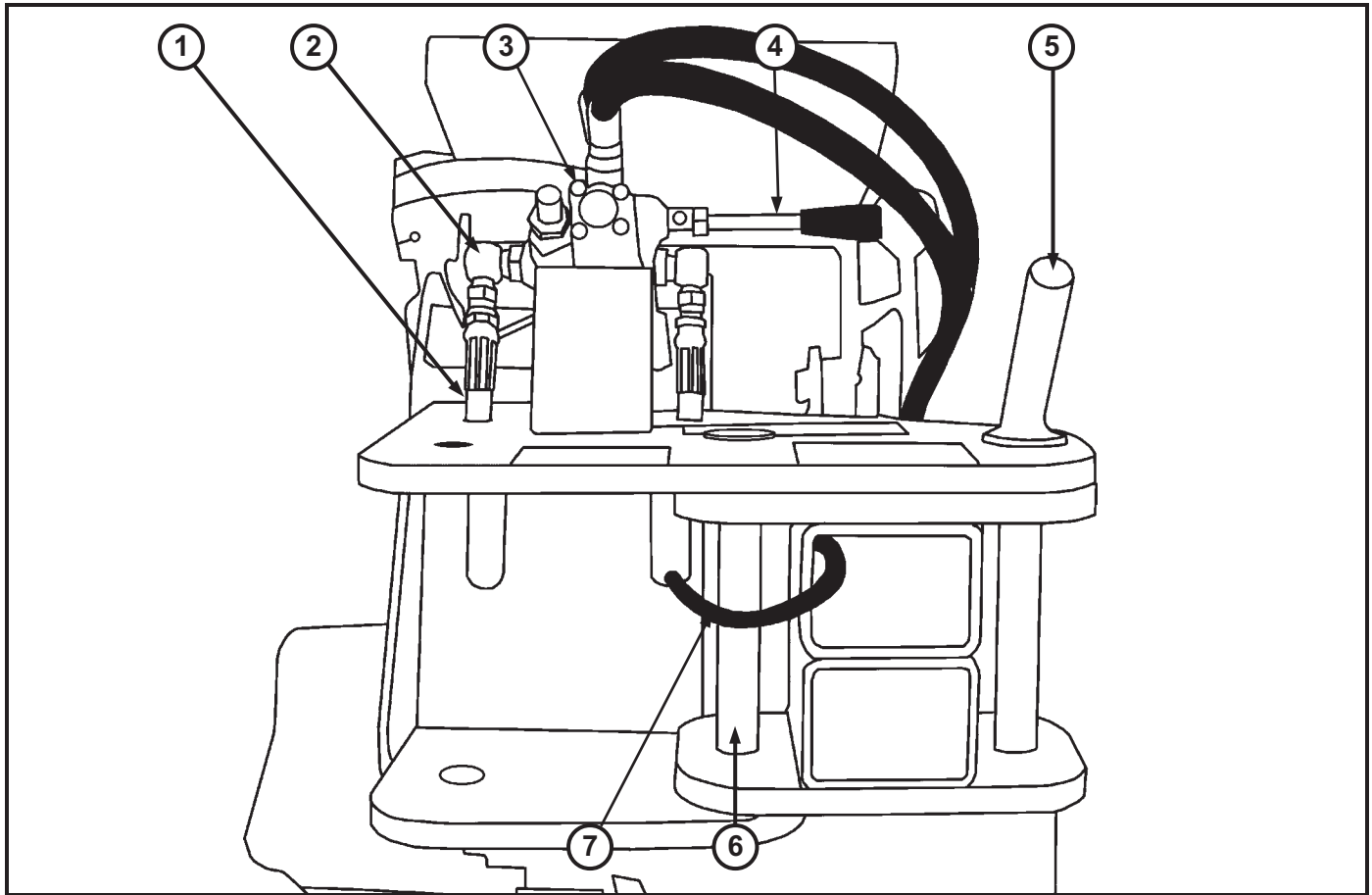

ITEM	PART NUMBER	DESCRIPTION	QTY.
1	38549	Hose, ³ / ₈ x 92", #8FJIC x #6FJIC, Sweeper Kubota	1
	38579	Hose, ³ / ₈ x 96", #8 FJIC x #6FJIC, Sweeper Deutz	
2	20149	Fitting, #8MB O-Ring x #6JIC90°, Tow-Bar Valve, Sweeper	3
3	38026	Valve, Tow-Bar, Sweeper	1
4	38659	Handle, Tow Bar Valve, Sweeper	1
5	38042	Pin, Upper Locking, Tow-Bar, Sweeper	1
6	38021	Pin, Tow-Bar, Sweeper	1
7	38453	Harness, Electrical, Tow-Bar, Sweeper	1

Parts

View of Right Front

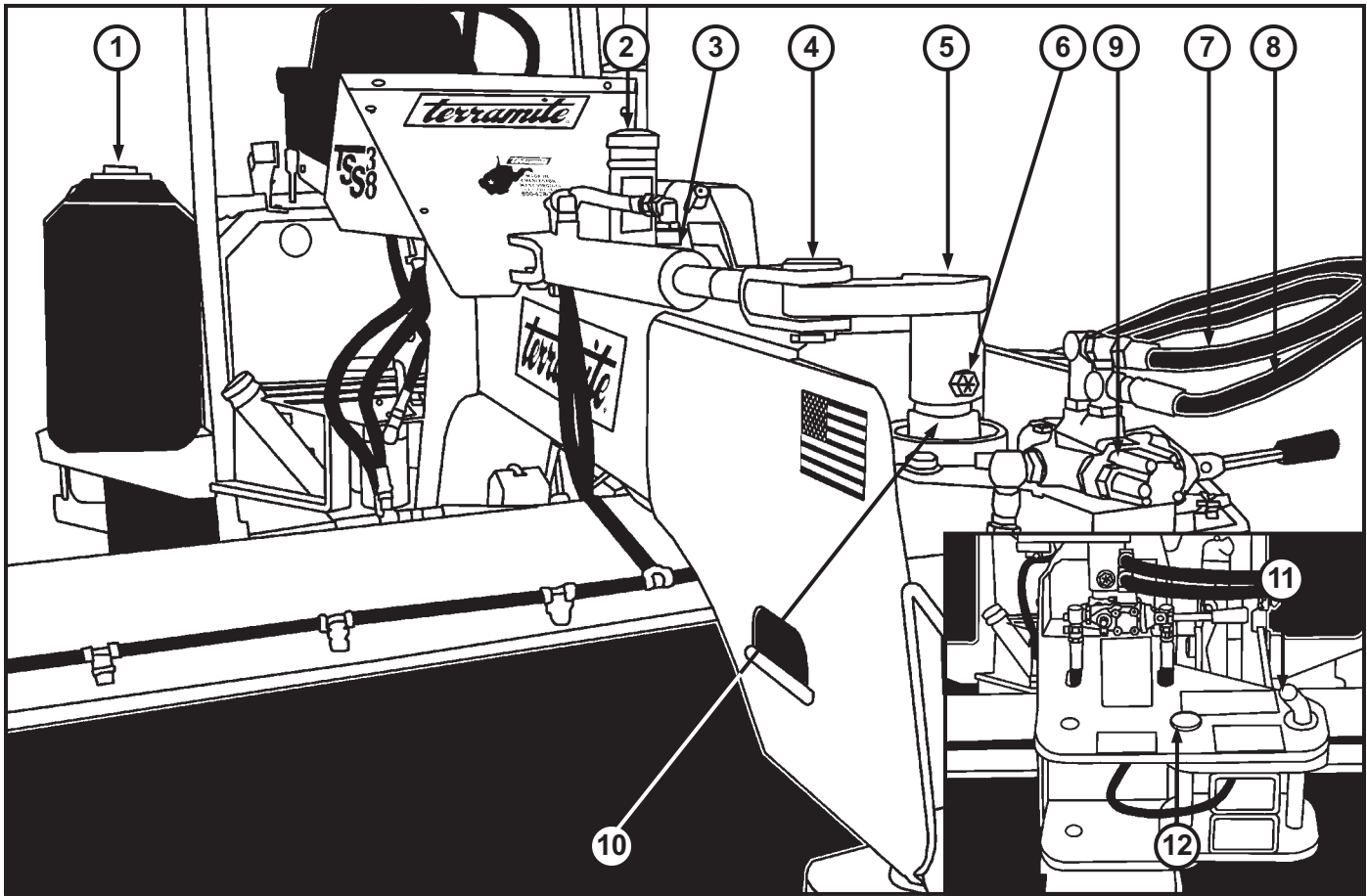

ITEM	PART NUMBER	DESCRIPTION	QTY.
1	38532	Cap, Water Tank Fill, Sweeper	2
2	38013	Cap, Locking, Fuel/Hydraulic Filler, Sweeper	2
3	38015	Cylinder, Steering, Sweeper	1
4	38420	Pin, Tow-Bar Lift/Steering Cylinder, Sweeper	2
5	38282	Arm, Steering, Sweeper	1
6	22158	Bolt, 1/2 x 3 1/4" GR8, Sweeper	1
7	38106	Hose, 3/8 x 37", #6FJIC Both, Cylinder, Tow-Bar Lift, Sweeper	1
8	38101	Hose, 3/8 x 31", #6FJIC Both, Cylinder, Tow-Bar Lift, Sweeper	1
9	38026	Valve, Tow-Bar, Sweeper	1
10	38169	Bearing, 4 Bolt Flange, Front Fork, Sweeper	2
11	38023	Pin, Upper Locking, Tow-Bar, Sweeper	1
12	38021	Pin, Tow-Bar, Sweeper	1

View of Right Side Front

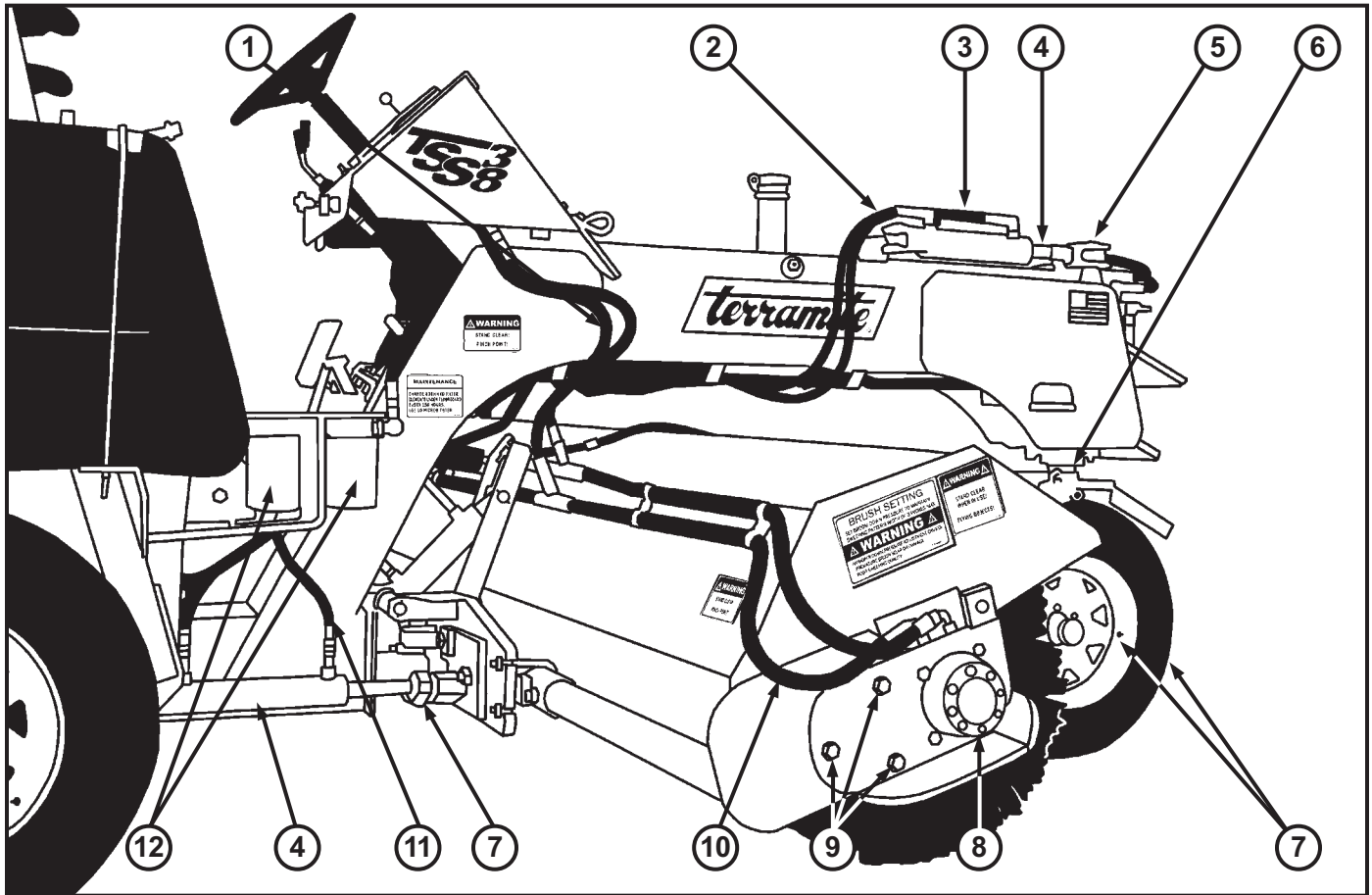

ITEM	PART NUMBER	DESCRIPTION	QTY.
1	38096	Hose, 1/2 x 39", #8FJIC x #8JICF90°, Sweeper	1
2	38551	Hose, 3/8 x 74", #6FJIC x #6FJIC90°, Sweeper	1
3	38550	Hose, 3/8 x 84", #6FJIC x #6FJIC90°, Sweeper	1
4	38015	Cylinder, Steering, Sweeper	1
5	38420	Pin, Tow-Bar Lift/Steering Cylinder, Sweeper	6
6	38169	Bearing, 4 Bolt Flange, Front Fork, Sweeper	2
7	38816	Assembly, Tire & Wheel, Sweeper	3
8	38232	Motor, Brush Core Drive, Sweeper	2
9	22154	Bolt, 1/2 - 13 x 11/2" NC Gr 8Z, Sweeper/T5C/D/G/T7	6
10	38129	Hose, 1/2 x 54", #8FJIC x #8FJIC90°, Sweeper	2
11	38112	Hose, 3/8 x 48", #6FJIC both, Sweeper	2
12	21002	Filter, Hydraulic, Sweeper	2

Parts

View of Right Side Front

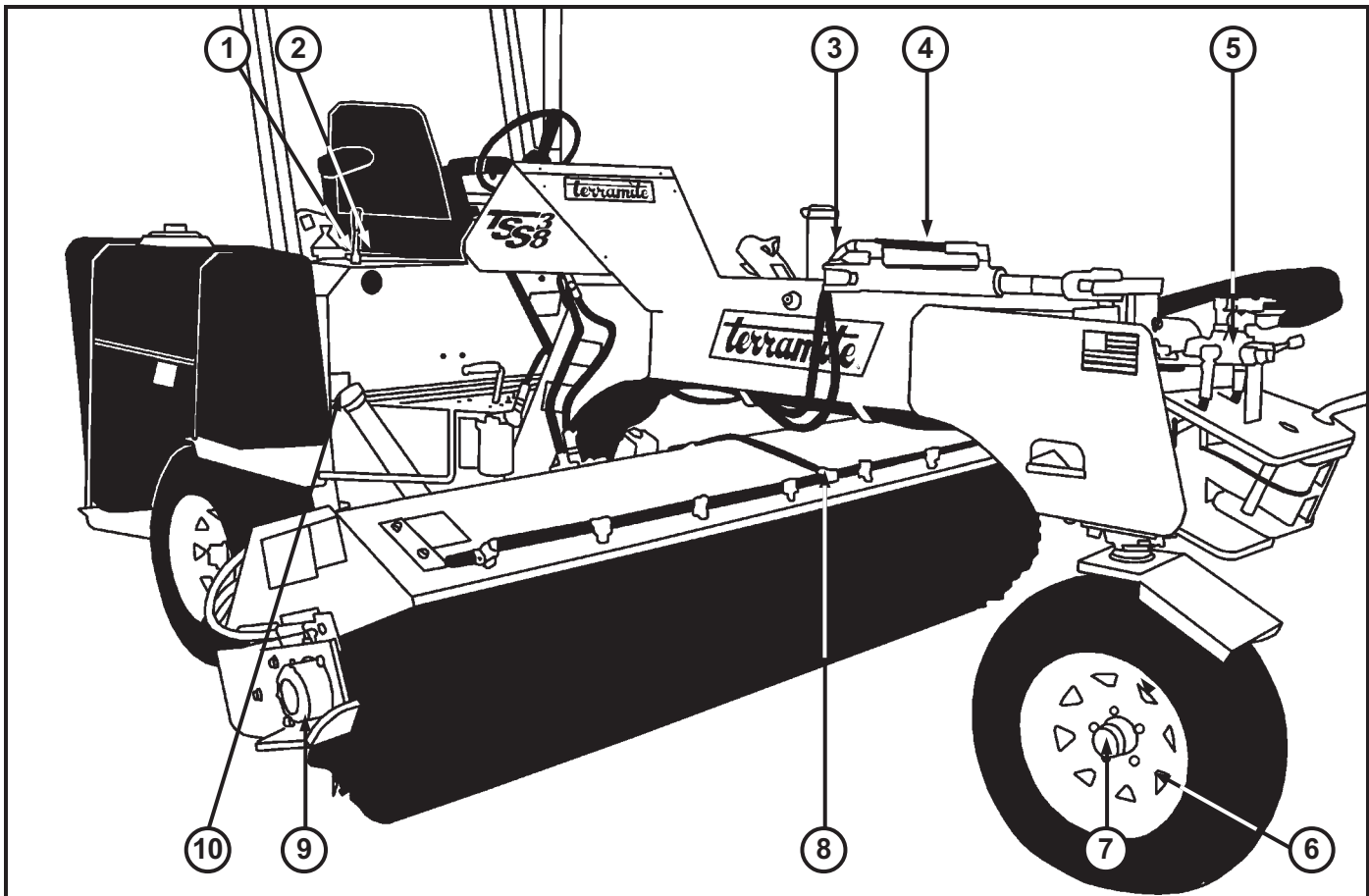

ITEM	PART NUMBER	DESCRIPTION	QTY.
1	38565	Boot, Forward/Reverse Valve, Sweeper	1
2	38086	Valve, Forward/Reverse, Sweeper	1
3	38551	Hose, 3/8 x 74", #6FJIC x #6FJIC90°, Sweeper	1
4	38550	Hose, 3/8 x 84", #6FJIC x #6FJIC90°, Sweeper	1
5	38026	Valve, Tow-Bar, Sweeper	1
6	38816	Assembly, Tire & Wheel, Sweeper	3
7	38047	Kit, Front Hub, Sweeper	1
8	20135	Fitting, 3/8 HBT 29 Brass, Waterline, Sweeper	2
9	38052	Motor, Brush Core Drive, Sweeper	2
10	38013	Cap, Locking, Fuel/Hydraulic Filler, Sweeper	2

View of Left Side Front

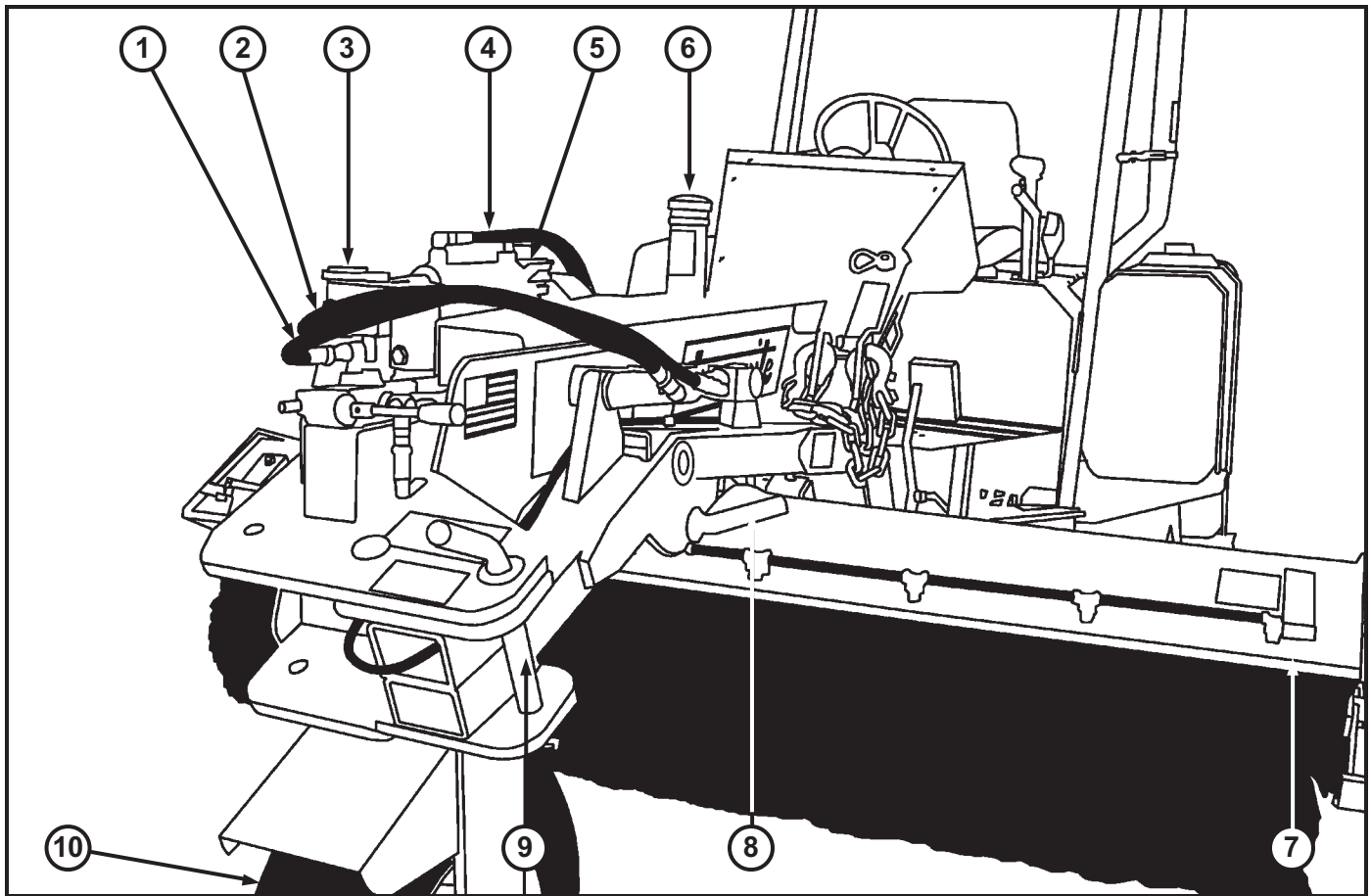

ITEM	PART NUMBER	DESCRIPTION	QTY.
1	38101	Hose, 3/8 x 31", #6FJIC Both, Cylinder, Tow-Bar Lift, Sweeper	1
2	38106	Hose, 3/8 x 37", #6FJIC Both, Cylinder, Tow-Bar Lift, Sweeper	1
3	38420	Pin, Tow-Bar Lift/Steering Cylinder, Sweeper	6
4	38550	Hose, 3/8 x 84", #6FJIC x #6FJIC90°, Sweeper	1
5	38015	Cylinder, Steering, Sweeper	1
6	38013	Cap, Locking, Fuel/Hydraulic Filler, Sweeper	2
7	38304	6 Foot Brush	1
	38305	8 Foot Brush	
8	38023	Pin, Lower Locking, Tow-Bar, Sweeper	1
9	38042	Pin, Upper Locking, Tow-Bar, Sweeper	1
10	38048	Assembly, Tire & Wheel, Sweeper	3

Parts

View of Left Side

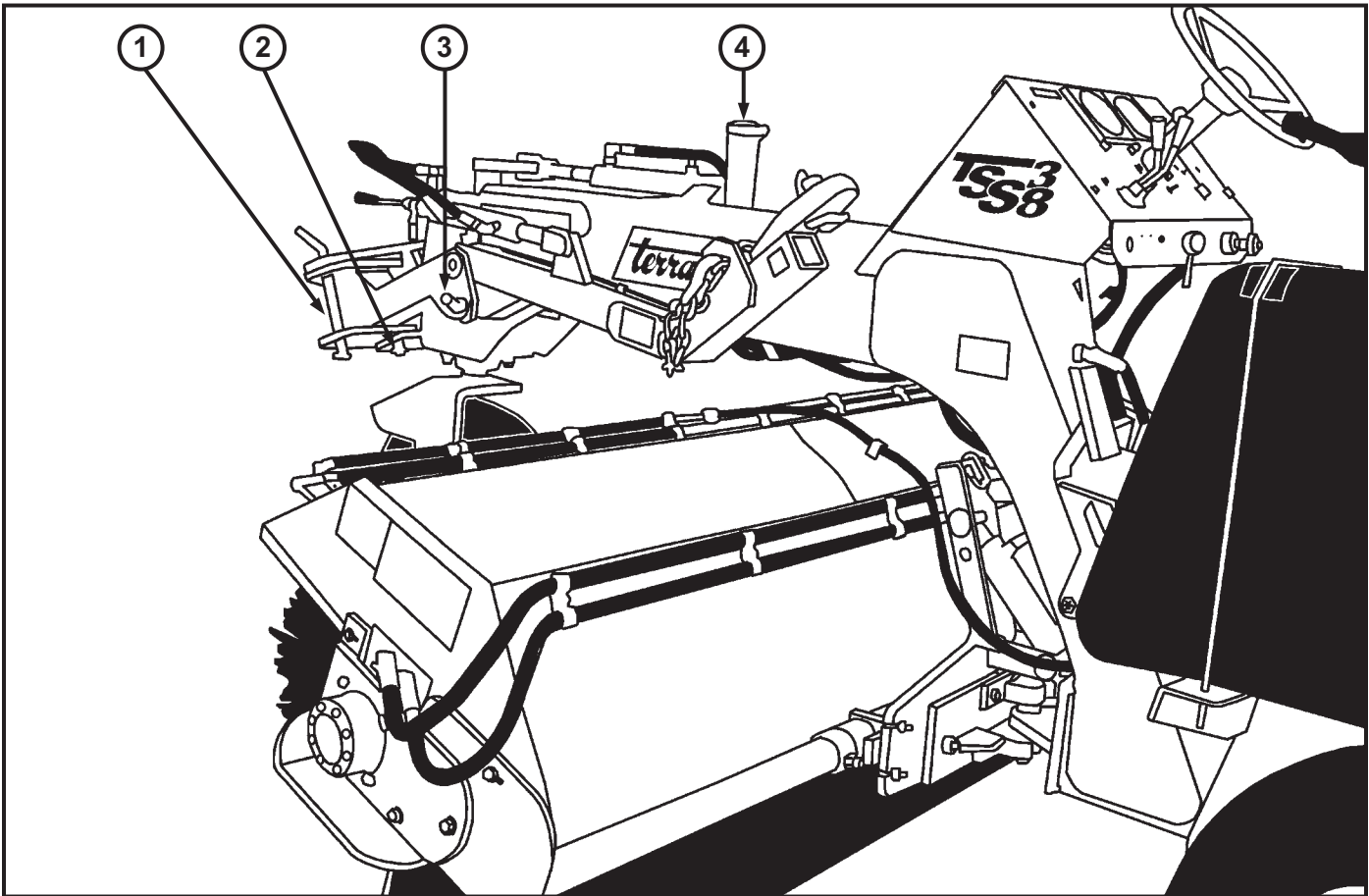

ITEM	PART NUMBER	DESCRIPTION	QTY.
1	38042	Pin, Upper Locking, Tow-Bar, Sweeper	1
2	38021	Pin, Tow-Bar, Sweeper	1
3	38023	Pin, Lower Locking, Tow-Bar, Sweeper	1
4	38013	Cap, Locking, Fuel/Hydraulic Filler, Sweeper	2

View of Right Side Brush Assembly

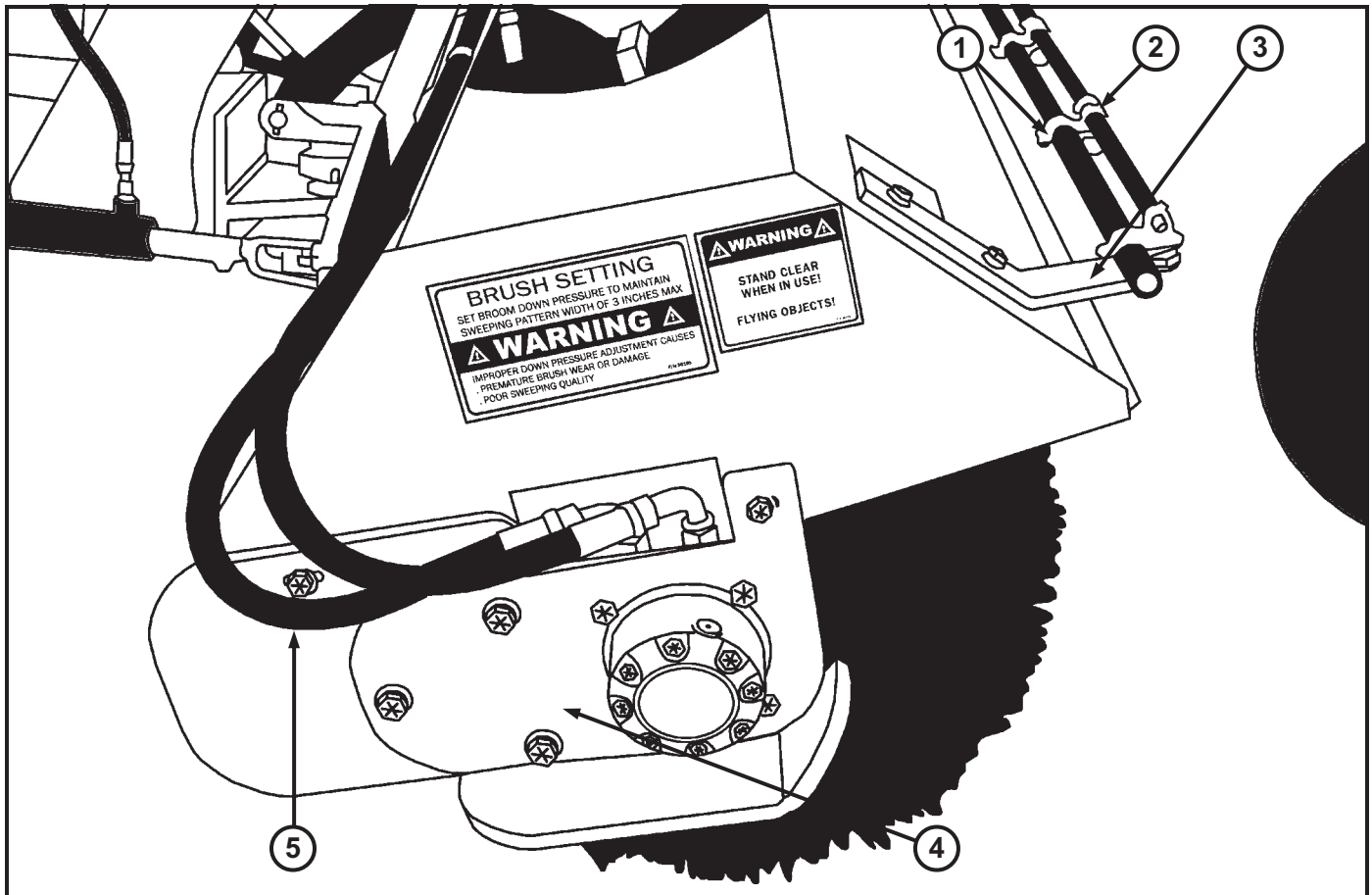

ITEM	PART NUMBER	DESCRIPTION	QTY.
1	38162	Clamp, Spray Bar to Push Lock Hose, Sweeper	8
2	38176	Clamp, 19/32", Spray Orifice, Sweeper	16
3	38304	Bar, Spray, Sweeper 6 Foot Brush	1
	38305	Bar, Spray, Sweeper 8 Foot Brush	
4	38402	Mount, Brush Core Motor, Sweeper Left Side	1
	38403	Mount, Brush Core Motor, Sweeper Right Side	
5	38571	Hose, #8FJIC x #8FJIC90°, 8 Ft. Brush, Sweeper, Left Side 1/2 x 74"	2
	38129	Hose, #8FJIC x #8FJIC90°, 8 Ft. Brush, Sweeper, Right Side 1/2 x 54"	
	38132	Hose, #8FJIC x #8FJIC90°, 6 Ft. Brush, Sweeper, Left Side 1/2 x 62"	2
	38096	Hose, #8FJIC x #8FJIC90°, 6 Ft. Brush, Sweeper, Right Side 1/2 x 39"	

Parts

View of Left Side Brush Assembly

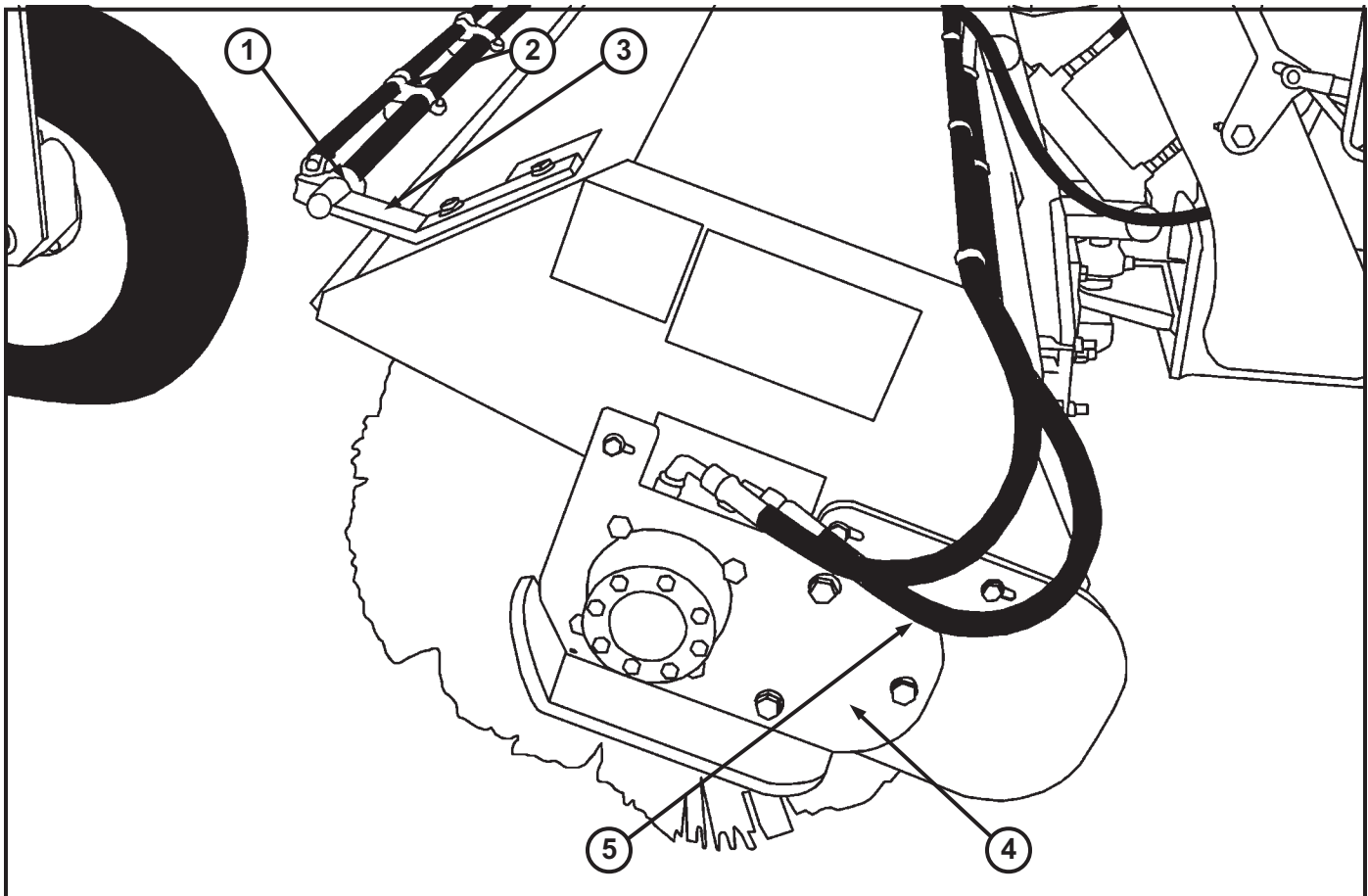

ITEM	PART NUMBER	DESCRIPTION	QTY.
1	38162	Clamp, Spray Bar to Push Lock Hose, Sweeper	8
2	38176	Clamp, 1 ⁹ / ₃₂ " , Spray Orifice, Sweeper	16
3	38304	Bar, Spray, Sweeper 6 Foot Brush	1
	38305	8 Foot Brush	
4	38402	Mount, Brush Core Motor, Sweeper Left Side	1
	38403	Right Side	
5	38571	Hose, #8FJIC x #8FJIC90°, 8 Ft. Brush, Sweeper, Left Side 1/2 x 74"	2
	38129	Right Side 1/2 x 54"	
	38132	Hose, #8FJIC x #8FJIC90°, 6 Ft. Brush, Sweeper, Left Side 1/2 x 62"	2
	38096	Right Side 1/2 x 39"	

View of Lower Right

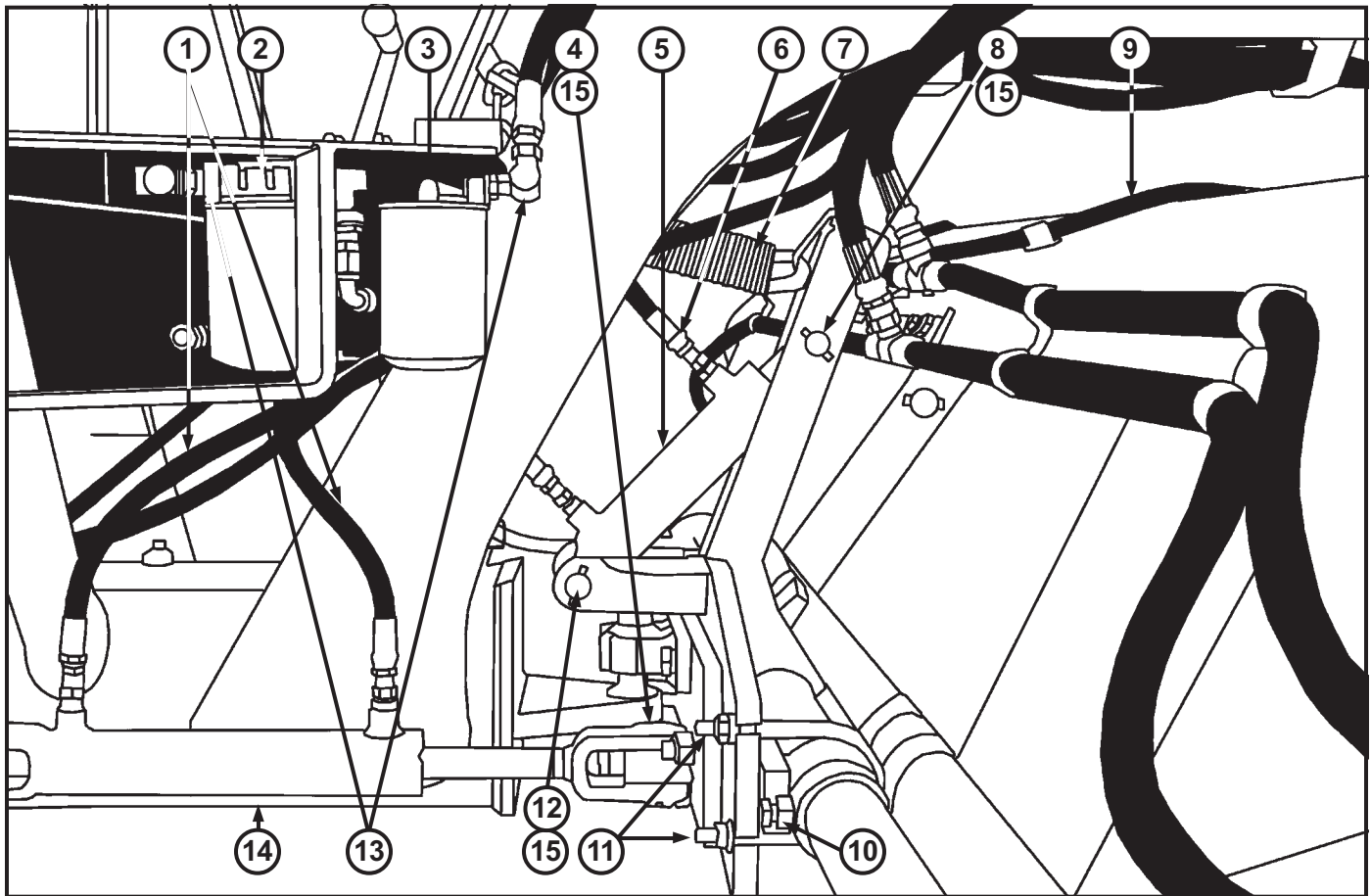

ITEM	PART NUMBER	DESCRIPTION	QTY.
1	38112	Hose, 3/8 x 48", #6FJIC Both, Sweeper	2
2	38075	Head, Filter, Blocked-By-Pass, Sweeper	1
3	38074	Head, Filter, 25PSI, Relief, Sweeper	1
4	38420	Pin, 1" x 2 1/8" Lg., Steering Cylinder, Sweeper	1
5	38016	Cylinder, Brush Lift, Sweeper	1
6	38110	Hose, 3/8 x 30", #6FJIC Both, Sweeper	1
7	38399	Spring, Large, Frame to Boom, Sweeper	1
8	38422	Pin, 1" x 4 1/2" Lg., Top Broom Lift, Sweeper	1
9	38387	Hose, 3/8", Push Lock, Sweeper	By Ft.
10	28019	Bolt, 1/2 x 1" GR8, Sweeper	2
11	22168	U-Bolt, W/Nuts "U", 1/2NF x 3IW x 6"L, Sweeper	2
12	38421	Pin, 1" x 5 1/8" Lg., Broom Lift, Sweeper	2
13	20172	Fitting, 1/2MP x #8MJIC90°, Sweeper	4
14	38017	Cylinder, Brush Angle, Sweeper	1
15	38506	Pin, Roll 1/4" x 1 1/2", Sweeper	7

Parts

View of Lower Left

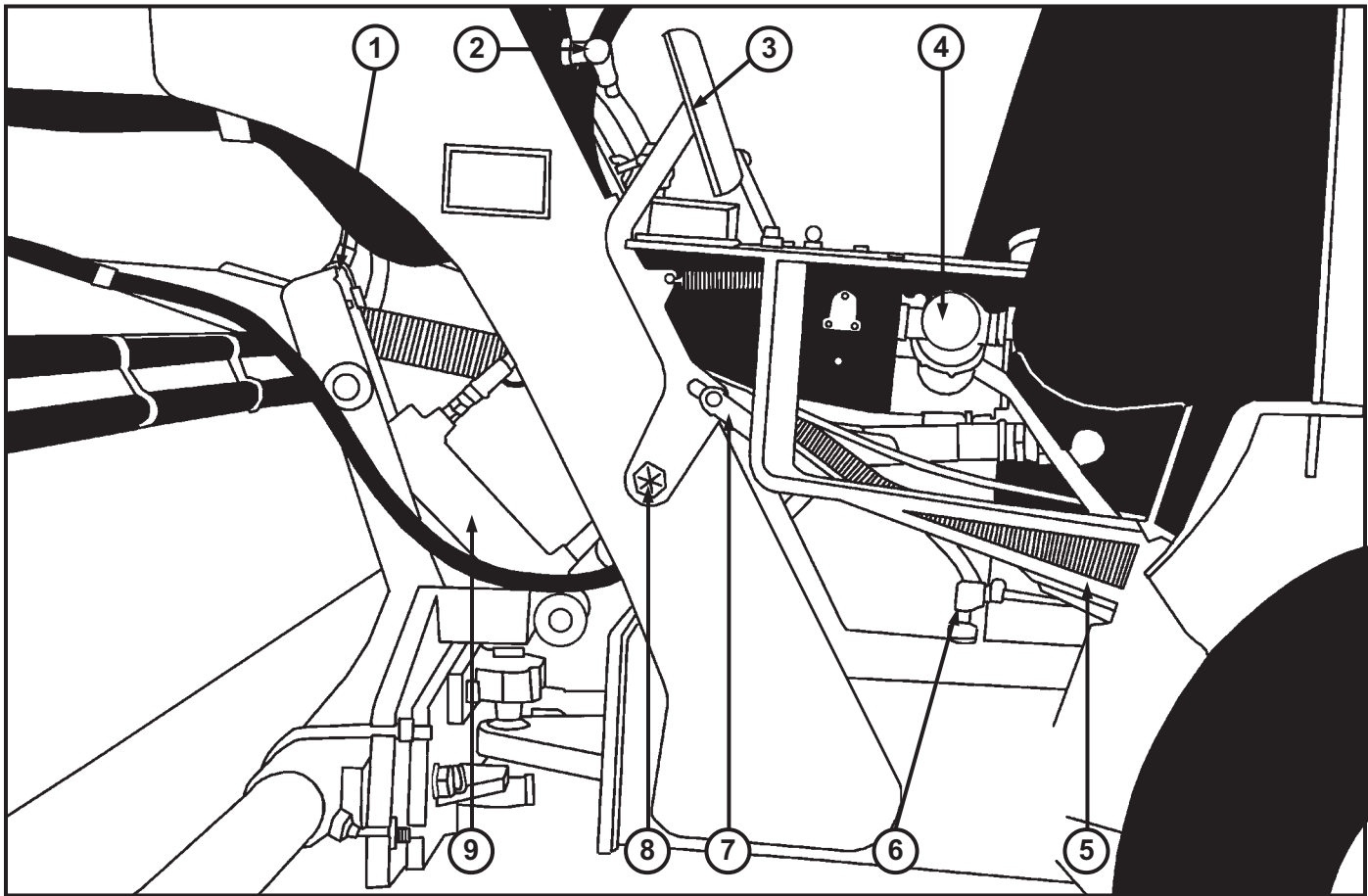

ITEM	PART NUMBER	DESCRIPTION	QTY.
1	38210	Link, Quick, 5/16", Sweeper	1
2	20172	Fitting, 1/2MP x #8MJIC90°, Sweeper	1
3	38465	Pedal, Brake, Sweeper	1
4	38165	Filter, Suction, Water-Pump, Sweeper	1
5	37464	Assembly, Rod Brake Pedal, Sweeper	1
6	38604	Fitting, Fuel Tank, 1/4FM x 1/4" FM90°, Sweeper	1
7	38475	Yoke, Lever, Brake, 1/2" - 20 NF, Sweeper	2
8	38515	Bolt, Shoulder, Pedal, 3/4 - 10 x 4" NC, Sweeper	1
9	38016	Cylinder, Brush Lift, Sweeper	1

View of Dash

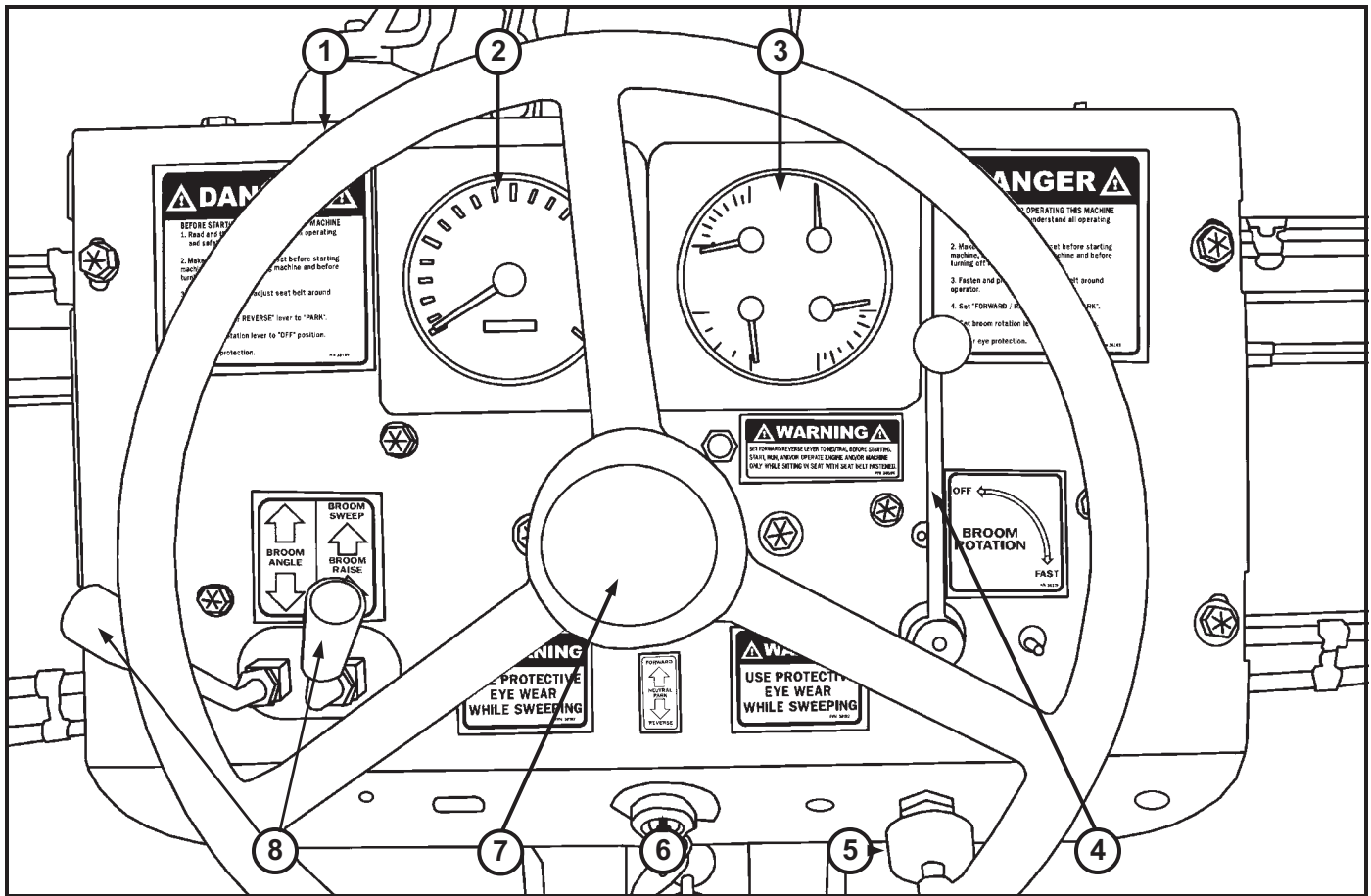

ITEM	PART NUMBER	DESCRIPTION	QTY.
1	38061	Wheel, Steering, Sweeper	1
2&3	72225	New Kit	1
4	38393	Lever, Brush Speed, Sweeper	1
5	38391	Cable, Throttle, Sweeper	1
	38502	Kubota Deutz	
6	70040	Switch, Ignition, Sweeper	1
	38590	Kubota - T5D/T7 Deutz	
7	38077	Cap, Steering Wheel, Sweeper	1
8	38660	Handle, Boom Lift/Angle Valve, Sweeper	2

Parts

View of Under Dash

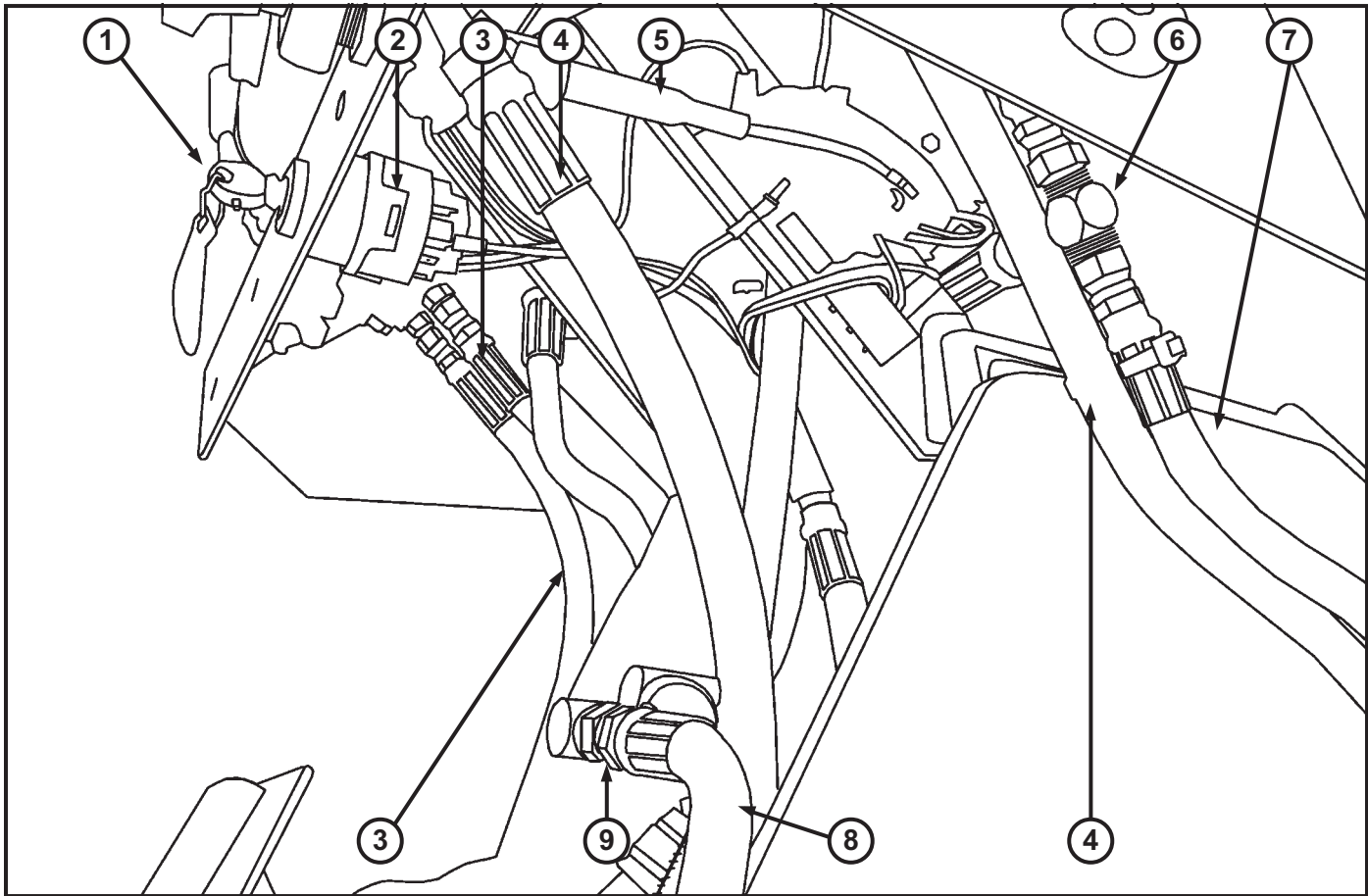

ITEM	PART NUMBER	DESCRIPTION	QTY.
1	38719	Key, Ignition, Sweeper Deutz	2
	70041	Kubota - T5D/T7	
2	38590	Switch, Ignition, Sweeper Deutz	1
	70040	Kubota - T5D/T7	
3	38112	Hose, 3/8 x 48", #6FJIC Both, Sweeper	2
4	38096	Hose, 1/2 x 39", #8FJIC x #8FJIC90°, Sweeper	2
5	38502	Cable, Throttle, Sweeper Deutz	1
	38391	Kubota	
6	20109	Fitting, #8MJIC "T", Sweeper	1
7	38520	Hose, 1/2 x 29", FX08W/hy08-08 FJ, Sweeper	1
8	38521	Hose, 1/2 x 10 1/2", FX08W/hy08, Sweeper	1
9	20172	Fitting, 1/2MP x #8MJIC90°, Sweeper	1

View of Behind Dash

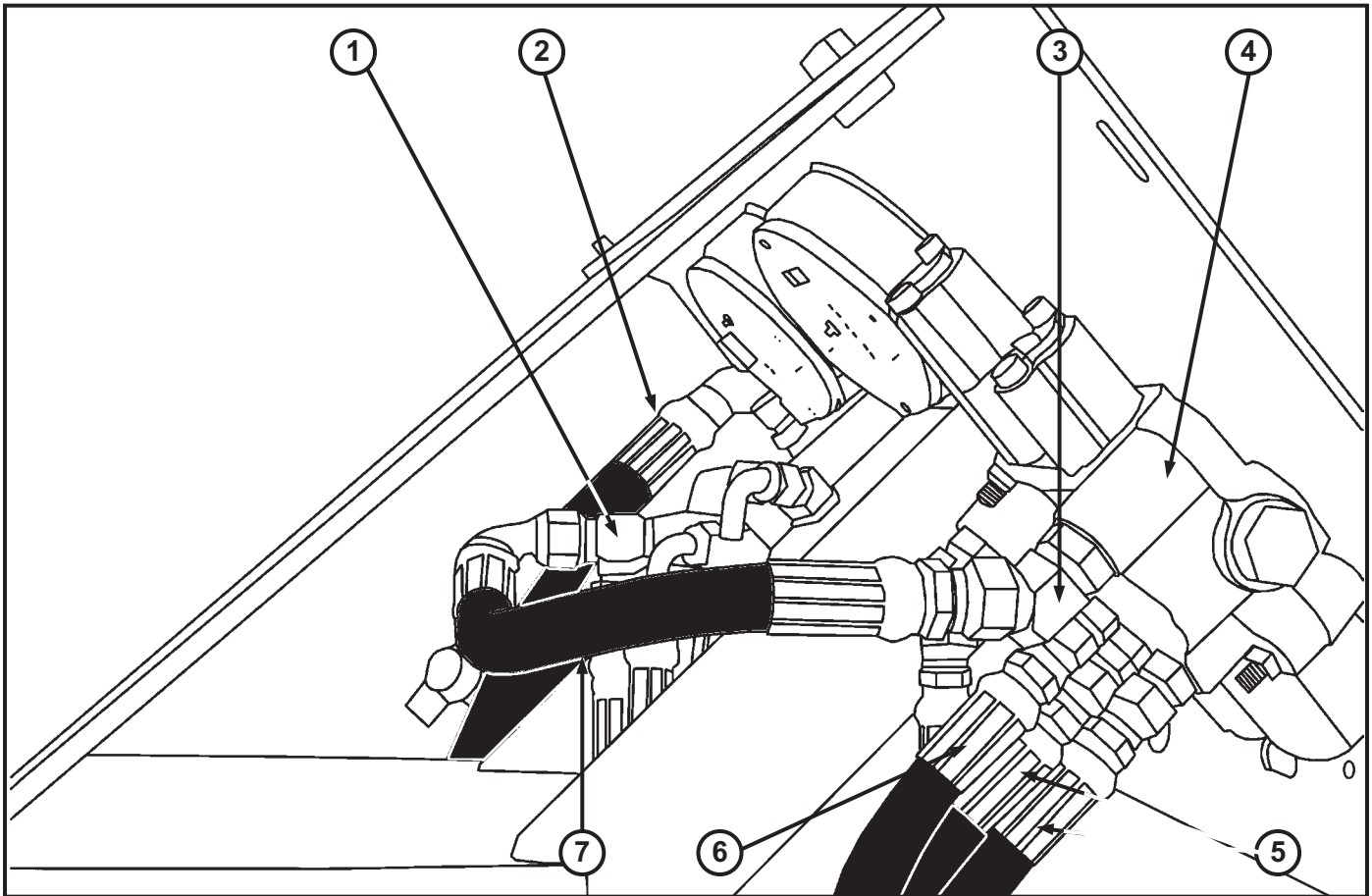

ITEM	PART NUMBER	DESCRIPTION	QTY.
1	38566	Fitting, #8 Swivel Nut Run "T", Sweeper	1
2	38096	Hose, 1/2 x 39", #8FJIC x #8FJIC90°, Sweeper	2
3	20179	Fitting, #8 O-Ring x #8JICM45°, Sweeper	1
4	38087	Valve, Lift/Angle, Sweeper	1
5	38112	Hose, 3/8 x 48", #6FJIC Both, Sweeper	2
6	38110	Hose, 3/8 x 30", #6FJIC Both, Sweeper	1
7	38570	Hose, 1/2 x 13", #8FJIC x #8FJIC90°, Sweeper	1

Parts

View of Underside of Dash

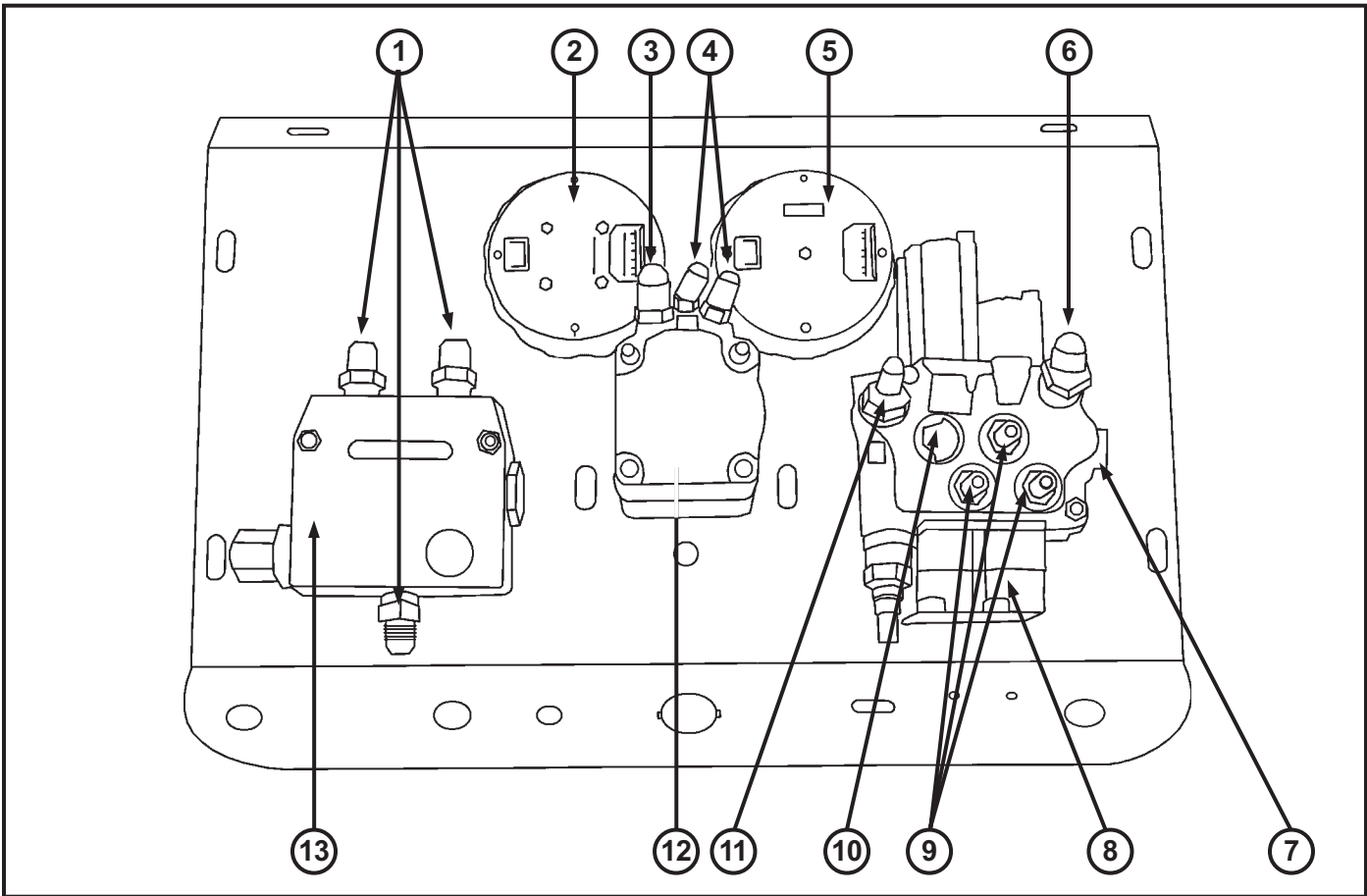

ITEM	PART NUMBER	DESCRIPTION	QTY.
1	20123	Fitting, #8MJIC x #8MP Straight, Sweeper	3
2	38024	Gauge, Fuel/Oil/Temp/Volts, Sweeper	1
3	20142	Fitting, #6 O-Ring x #8MJIC45°, (Forged), Sweeper	1
4	20112	Fitting, #6 O-Ring x #6MJIC45°, (Forged), Sweeper	4
5	38043	Gauge, Hourmeter/Tachometer Cluster, Sweeper	1
6	20179	Fitting, #8 O-Ring x #8JICM45°, Sweeper	1
7	20167	Fitting, Hex Head, #8 Plug, Sweeper	1
8	38087	Valve, Lift/Angle, Sweeper	1
9	20111	Fitting, #6 O-Rng x #6MJIC Straight, Sweeper	3
10	20134	Fitting, #6 O-Ring Plug, Sweeper	1
11	20173	Fitting, #8 O-Ring x #6JICM45°, Sweeper	1
12	38537	Gear, Steering, Sweeper	1
13	38082	Valve, Control, Variable, Broom RDRS-105-16, Sweeper	1
2 & 5	72225	New Gauge, Sweeper	1

View from Back of Operator's Seat Left Side

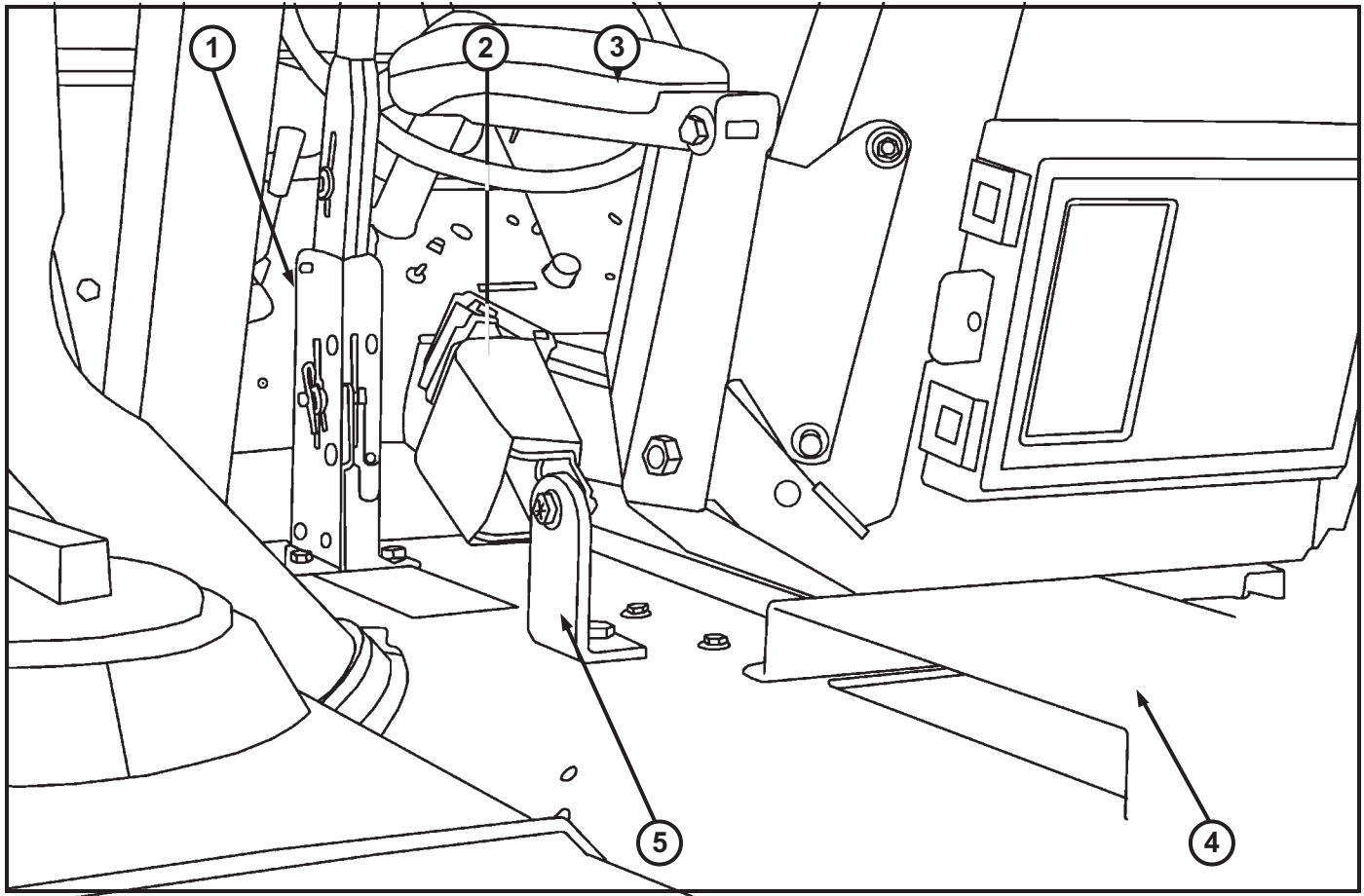

ITEM	PART NUMBER	DESCRIPTION	QTY.
1	38083	Handle, Brake, Sweeper	1
2	11903	Belt, Seat, Sweeper/T5C/D/G/T7/T6/T9	2
3	11045	Set, Arm Rest, Sweeper/T5/T5D/G/T7/T6/T9	1
4	38364	Panel, Top, Engine, Sweeper	1
	38362		
5	38477	Bracket, Seat Belt Mounting, Sweeper	2

Parts

View from Inside Rear Panel

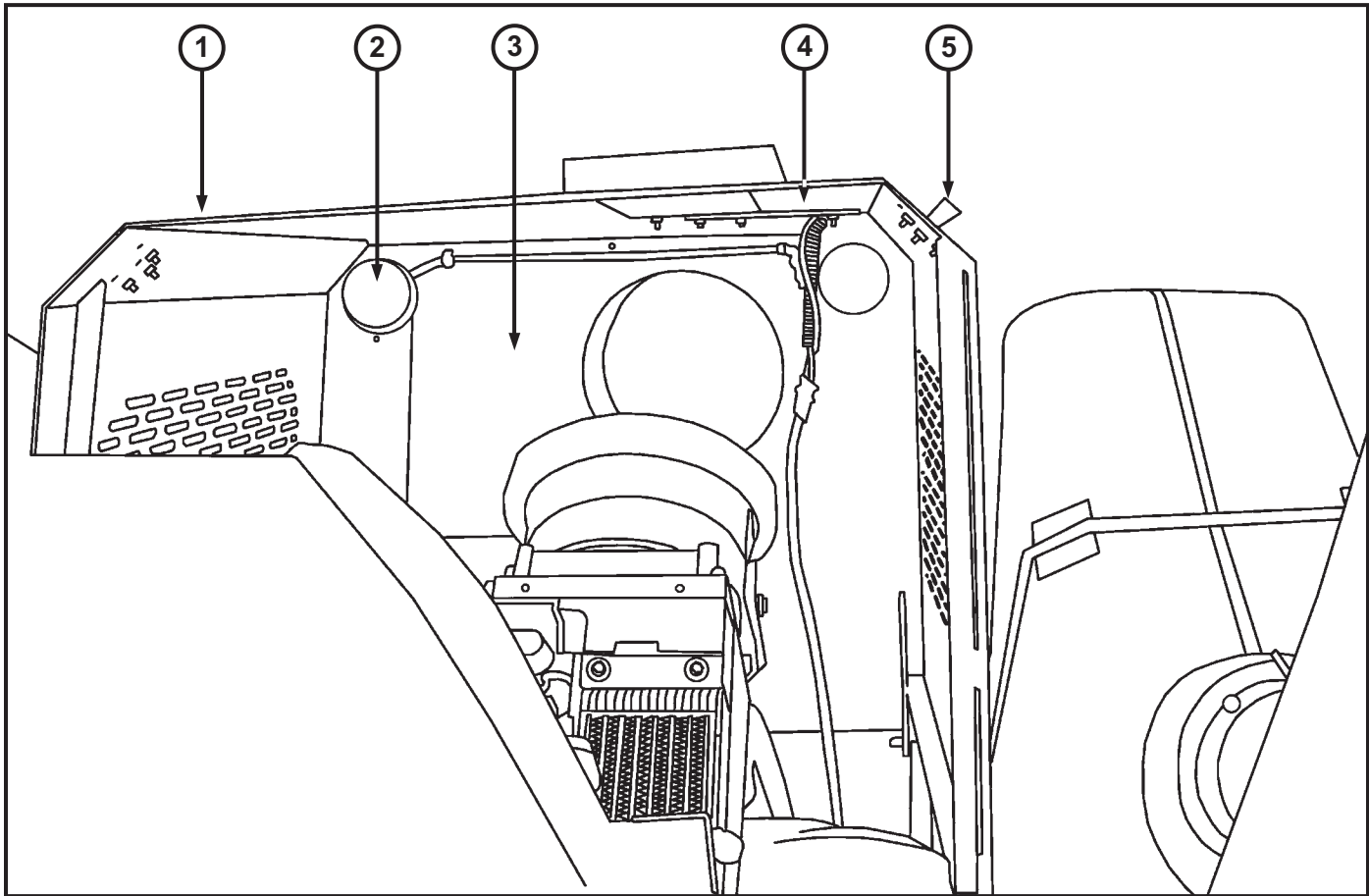

ITEM	PART NUMBER	DESCRIPTION	QTY.
1	38351	Hood, Engine, Sweeper	1
2	38084	Light, Stop/Turn/Tail, Sweeper	2
3	38363	Panel, Cover, Rear, Engine, Sweeper	1
	38361		
4	38450	Bracket, Tail Light Harness, Sweeper	1
5	38143	Latch, Engine Hood, Sweeper	2
NOT SHOWN	70116	Battery, T4/T5C/D/T6/T7/T9/Screed/Sweeper	1
	77022		
NOT SHOWN	38723	Cable, Negative Battery, Sweeper	1
NOT SHOWN	72001	Cable, Ground Strap, 12" Eye x Eye, T6/T9/Sweeper	1
NOT SHOWN	38722	Cable, Positive Battery, Sweeper	1
NOT SHOWN	38718	Hold Down, Battery, Sweeper	2
NOT SHOWN	38901	Hood Assy. W/Lights	1

View of Rear Engine Area

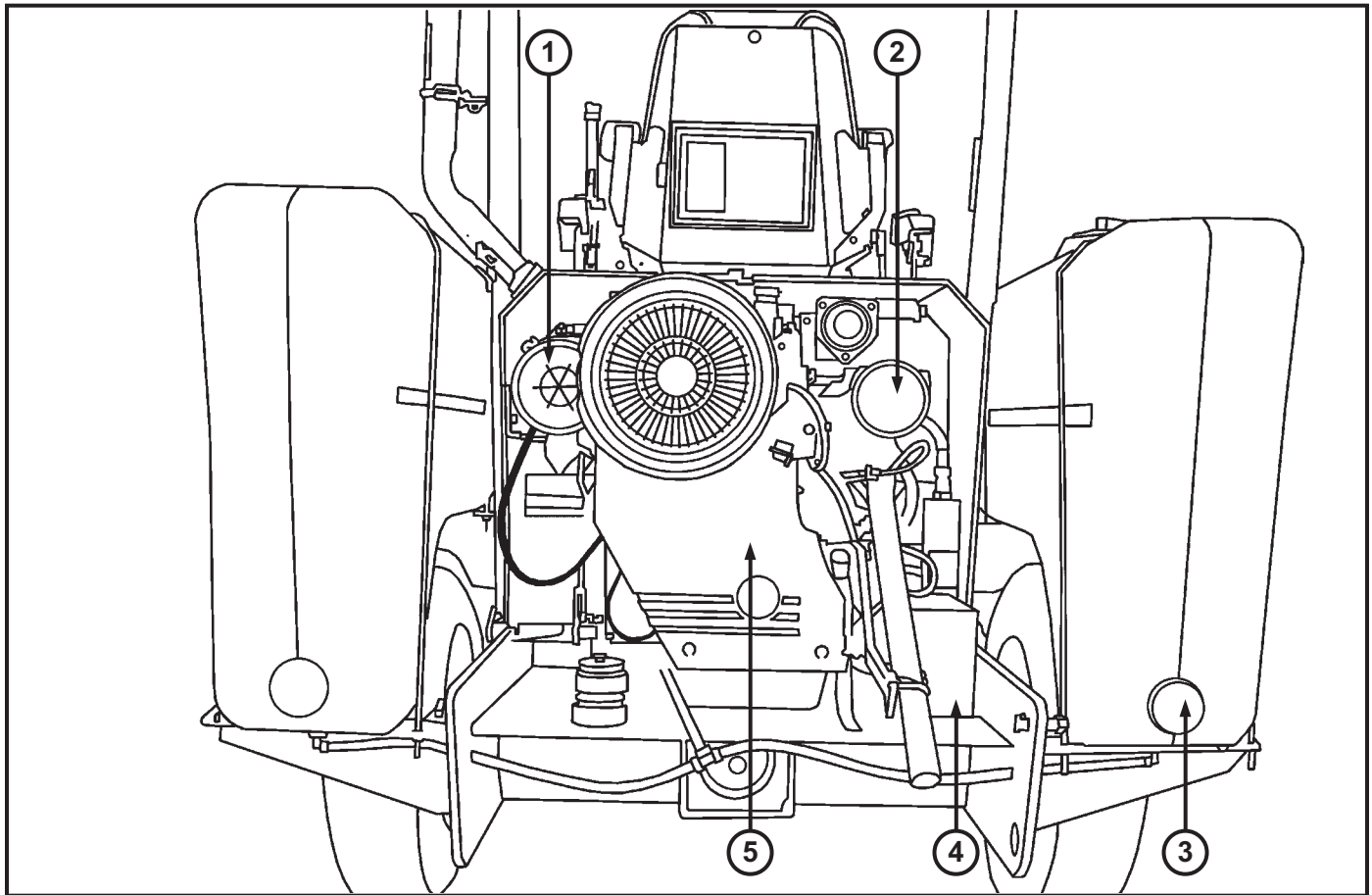

ITEM	PART NUMBER	DESCRIPTION	QTY.	
1	38150	Filter, Air, Sweeper	1	
	38214			Deutz
	41072			Kubota Kubota, New
2	38170	Muffler, Sweeper	1	
	38728			Deutz Kubota
3	38580	Plug, Drain, Water Tank, Sweeper	2	
4	70116	Battery, Sweeper	1	
	77022			Deutz Kubota
5	38652	Assembly, Engine, Sweeper	1	
	38651			Deutz Kubota

Parts

Rear View of Transmission/Pump Assembly

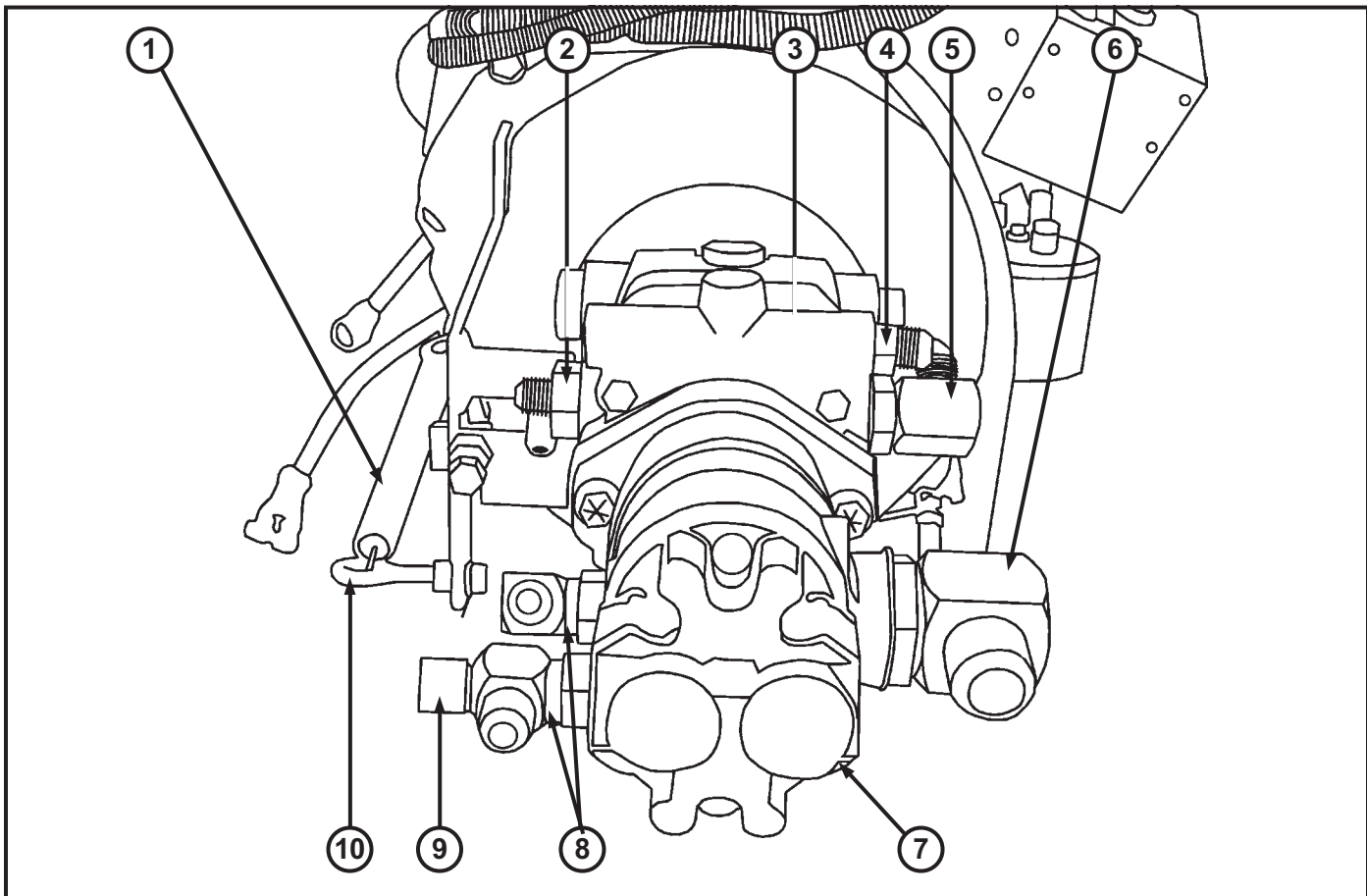

ITEM	PART NUMBER	DESCRIPTION	QTY.
1	39025	Spring, Forward/Reverse Pedal, Sweeper	1
2	20140	Fitting, #12 O-Ring x #8MJIC, Sweeper	1
3	38058	Pump, Main Transmission, Sweeper	1
4	20035	Fitting, #8 O-Ring x #8MJIC, T5D/T7/T9/Sweeper	1
5	20040	Fitting, #12 O-Ring x #8MJIC90°, T6/T9/Sweeper	1
6	20041	Fitting, 1 1/4 O-Ring x 1" JIC90°, T6/T9/Sweeper	1
7	38536	Pump, Tandem, Eaton, Sweeper	1
8	20124	Fitting, #8MJIC x #10 O-Ring 90° w/Check P, Sweeper	2
9	20116	Fitting, "L" 1/4", Sweeper	1
10	38513	Bolt, Eye, 3/8 - 16 x 2", Sweeper	2

Left Side View of Transmission/Pump Assembly

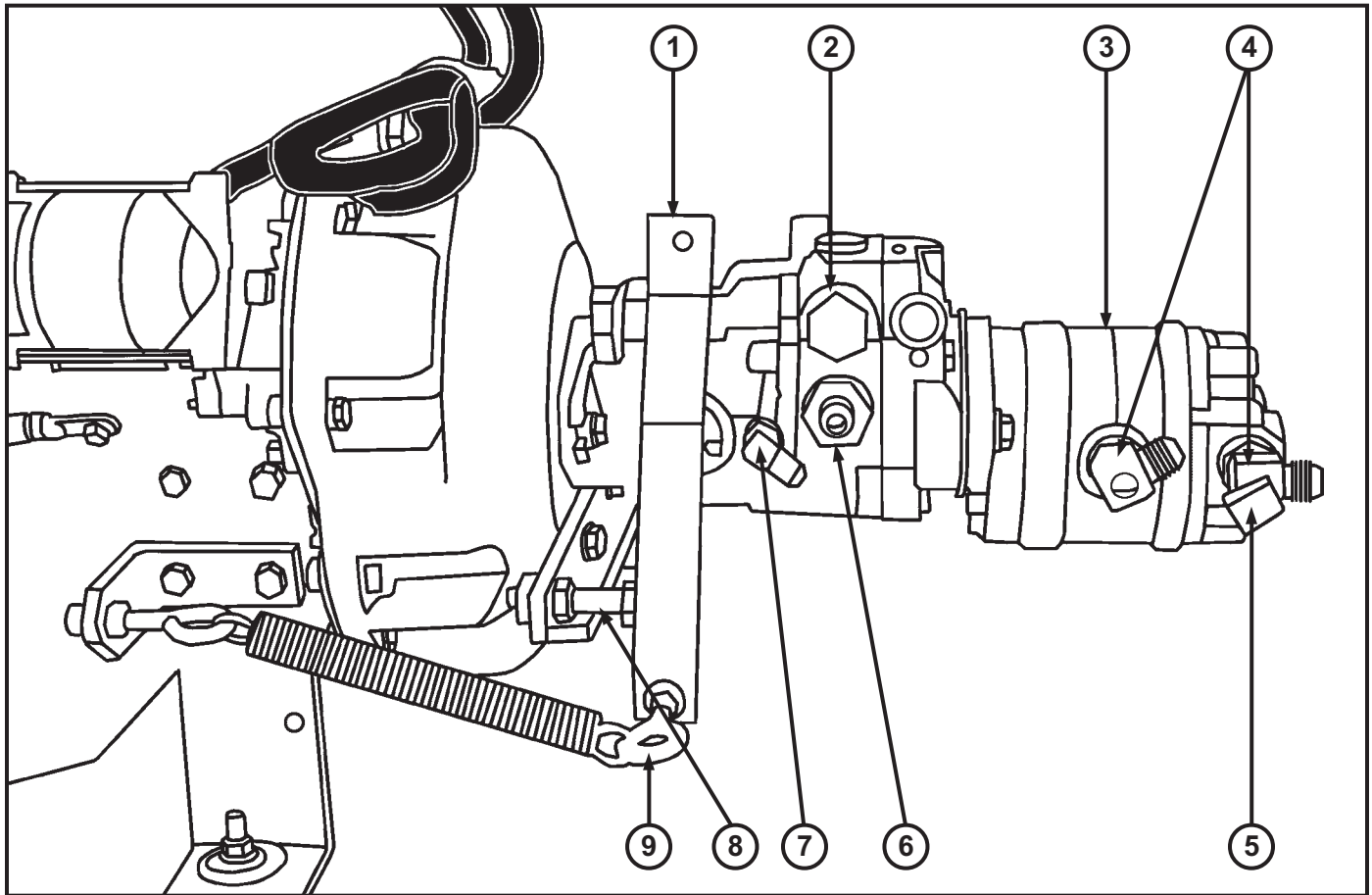

ITEM	PART NUMBER	DESCRIPTION	QTY.
1	38294	Arm, Welded Pump, Sweeper	1
	38611		
2	38058	Pump, Main Transmission, Sweeper	1
3	38536	Pump, Tandem, Eaton, Sweeper	1
4	20124	Fitting, #8MJIC x #10 O-Ring 90° w/Check P, Sweeper	2
5	20116	Fitting, "L" 1/4", Sweeper	1
6	20140	Fitting, #12 O-Ring x #8MJIC, Sweeper	1
7	20144	Fitting, #6 O-Ring x #6MJIC90°, Sweeper	1
8	28022	Bolt, 1/2 x 2 1/4" GR8, Sweeper	1
	39025	Assembly	1

Parts

View of Under Seat Area

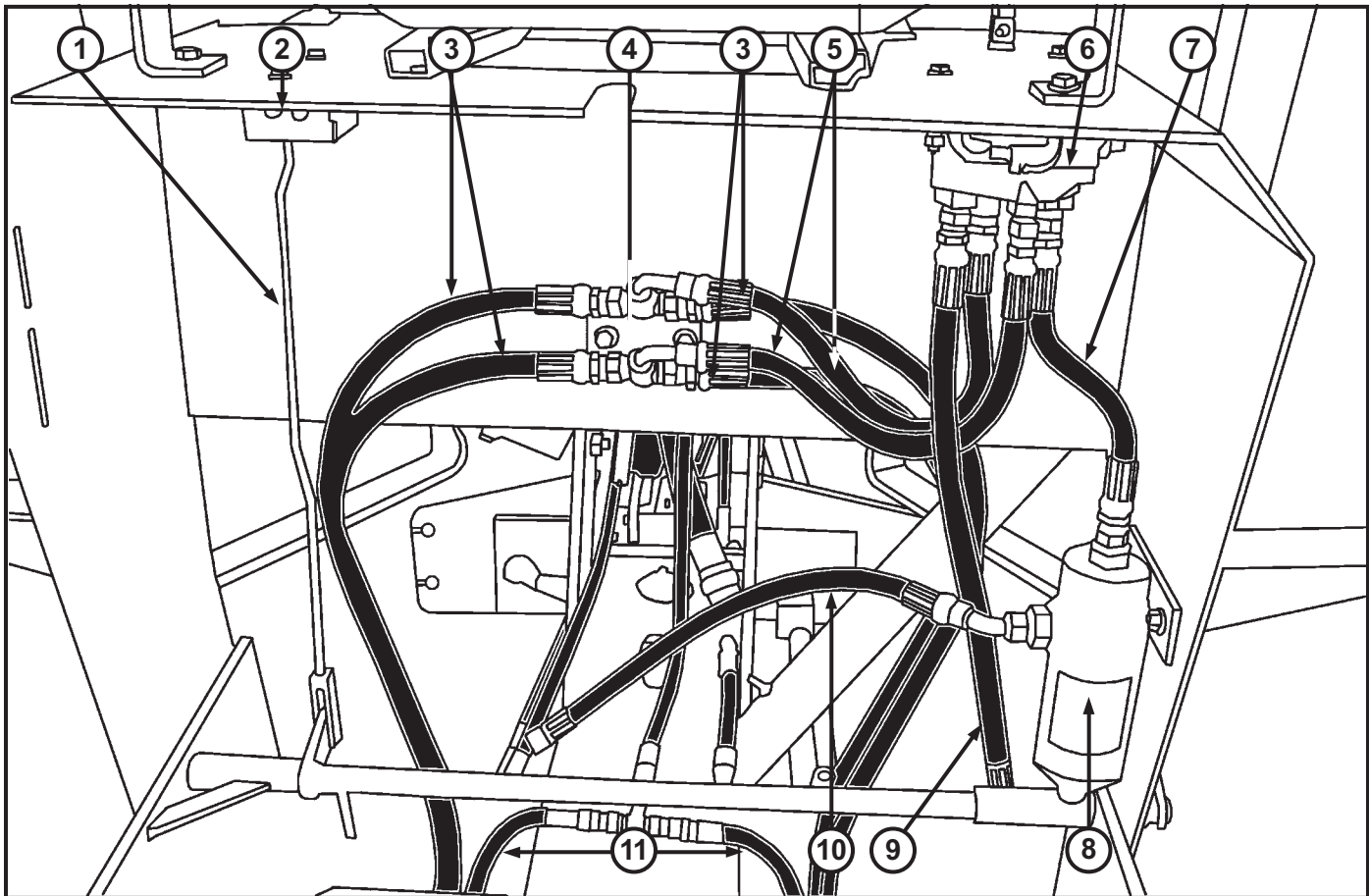

ITEM	PART NUMBER	DESCRIPTION	QTY.
1	38379	Rod, Brake Lever, Plated, Sweeper	1
2	77510	Alarm, Back-Up, T5C/D/T6/T7/T9/Sweeper	1
3	38097	Hose, 1/2 x 36", #8FJIC x #8FJIC90°, Sweeper	4
4	38343	"T" Block, Sweeper	1
5	38091	Hose, 1/2 x 19 1/2", #8FJIC x #8FJIC90°, Sweeper	2
6	38086	Valve, Forward/Reverse, Sweeper	1
7	38095	Hose, 1/2 x 12", #8FMJICSTR Both, Sweeper	1
8	38019	Assembly, Filter, High Pressure, Sweeper	1
9	38090	Hose, 1/2 x 25", #8FMJIC Both, Sweeper	1
10	38089	Hose, 1/2 x 25", #8FJIC x #8FJIC45°, Sweeper	1
11	38528	Hose, 3/8 x 12", HY06-06FJ-06FJ9, Sweeper	2

View of Lock Out

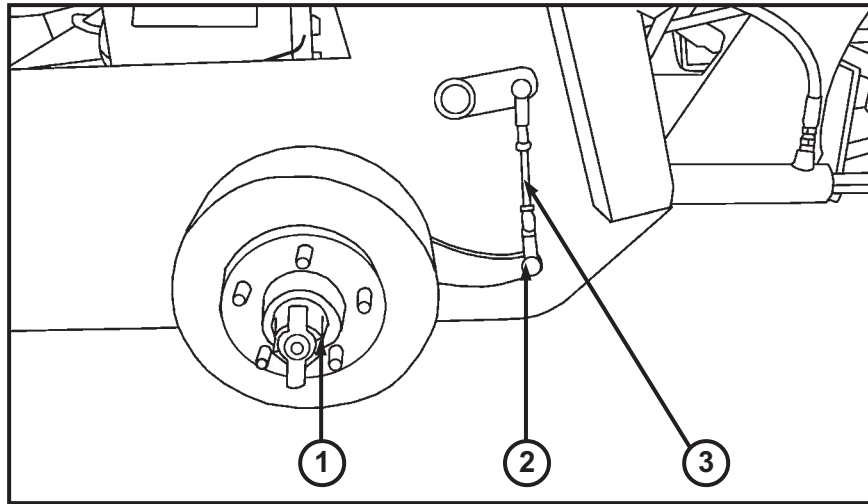

ITEM	PART NUMBER	DESCRIPTION	QTY.
1	38085	Assembly, Brake/Disconnect, Sweeper	2
2	38144	Clevis, Weldable, 5/16 - 24, Screed/Sweeper	2
3	38378	Rod, Bellcrank Control, 4 5/8" L, Sweeper	1

Left Side Brush Assembly Breakdown

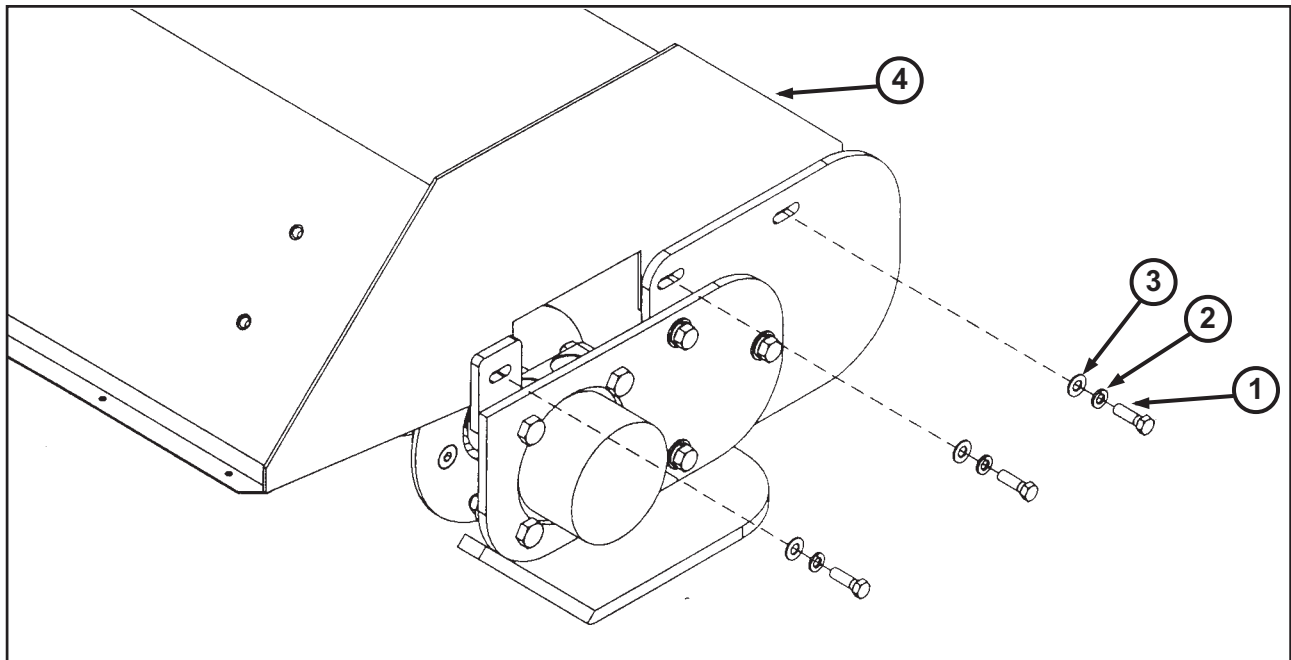

ITEM	PART NUMBER	DESCRIPTION	QTY.
1	22123	1/2" - 13 x 1 1/2" Bolt	6
2	22171	1/2" Lock Washer	6
3	28044	1/2" Flat Washer SAE	6
4	38302	6' Brush Hood	1
	38303	8' Brush Hood	1

Parts

Front Fork Assy.

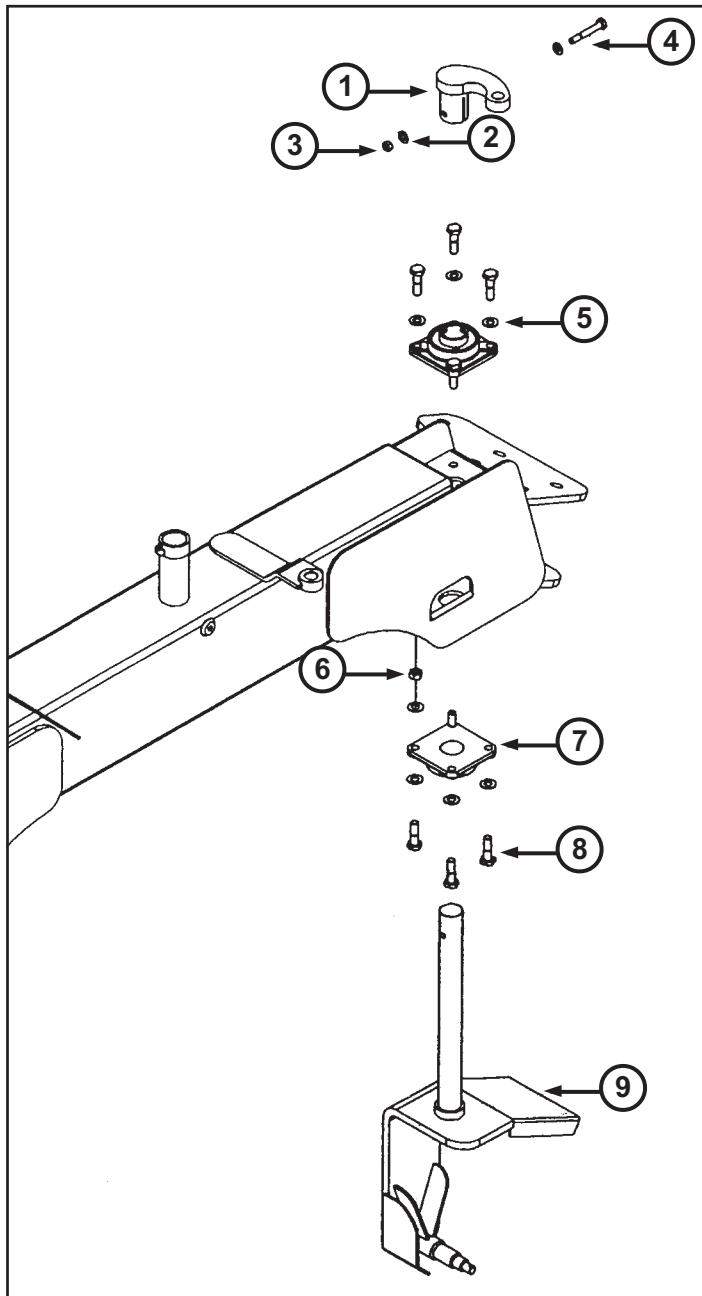

ITEM	PART NUMBER	DESCRIPTION	QTY.
1	38282	Steering Arm	1
2	28042	1/2 Washer	1
3	23034	1/2 Lock Nut	1
4	22158	1/2 Bolt	1
5	28047	5/8 Washer	16
6	22166	5/8 Lock Nut	8
7	38169	4 Bolt Flange Bearing	2
8	22160	5/8 Bolt	8
9	38275	Sweeper Front Fork	1

Water System Routing

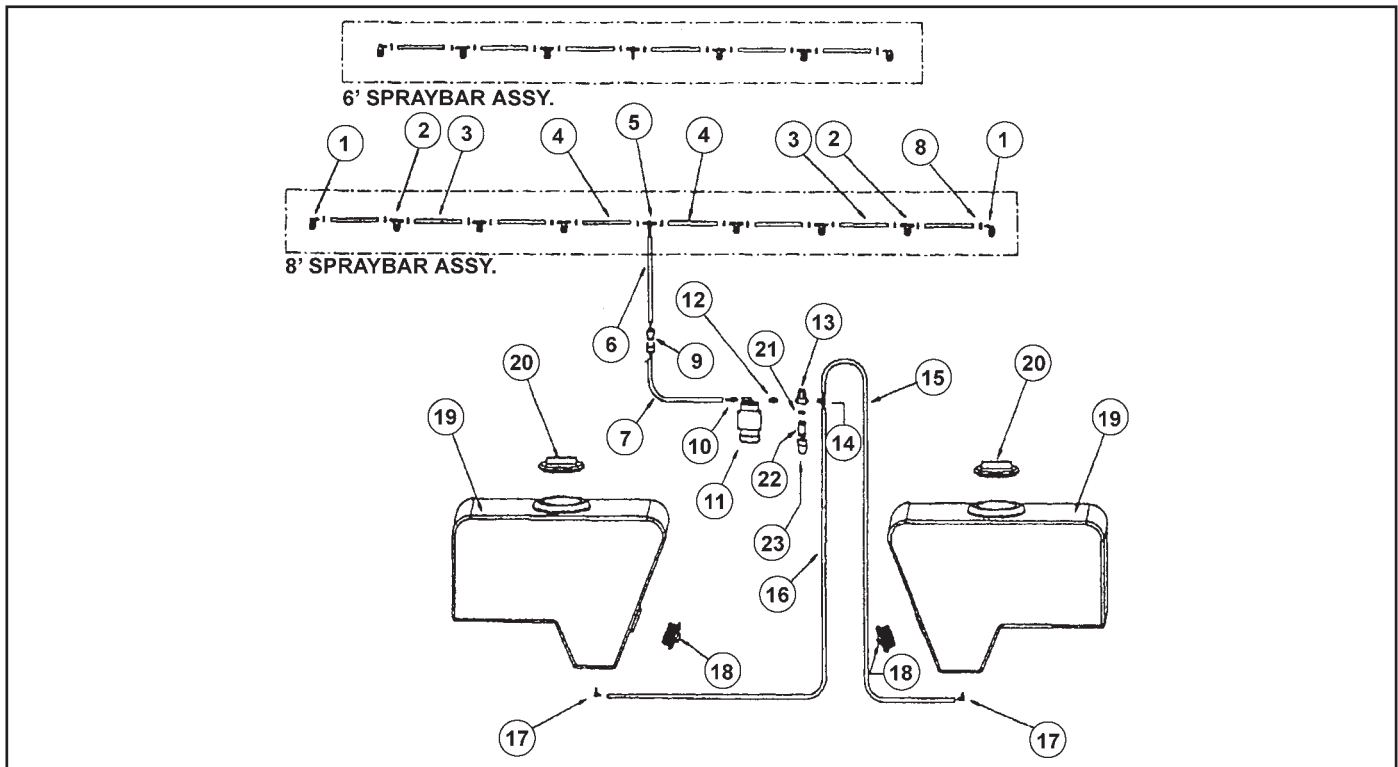

ITEM	PART NUMBER	DESCRIPTION	6' QTY.	8' QTY.
1	38161	90 Degree Body	2	2
2	38160	"T" Body	5	7
3	38152	3/8 Hose x 9"	5	7
4	38153	3/8 Hose x 4"	2	2
5	38163	3/8 Plastic "T"	1	1
6	38154	3/8 Hose x 19"	1	1
7	38155	3/8 Hose x 16"	1	1
8	38176	3/8 Crimp Clamp	22	24
9	38201	Water Hose Connector	1	1
10	38170	3/8 Mnpt x 90 Deg. x 3/8 Barb	1	1
11	38168	Water Pump	1	1
12	38166	3/8 Mnpt x 1/2 Mnpt. Step Nipple	1	1
13	38165	Water Pump Filter	1	1
14	38167	1/2 Mnpt. x 3/8 Barb	1	1
15	38202	3/8" Hose (Right) x 75"	1	1
16	38203	3/8" Hose (Left) x 65"	1	1
17	38170	3/8" Mnpt. x 90 Deg. x 3/8 Barb	2	2
18	38204	Water Tank Drain Plug	2	2
19	38390	Water Tanks	2	2
20	38205	Water Tank Cap	2	2
21		Filter "O" Ring (Spare Parts)	1	1
22		Filter Element (Spare Parts)	1	1
23		Filter Bowl (Spare Parts)	1	1

Parts

Sprayer Parts

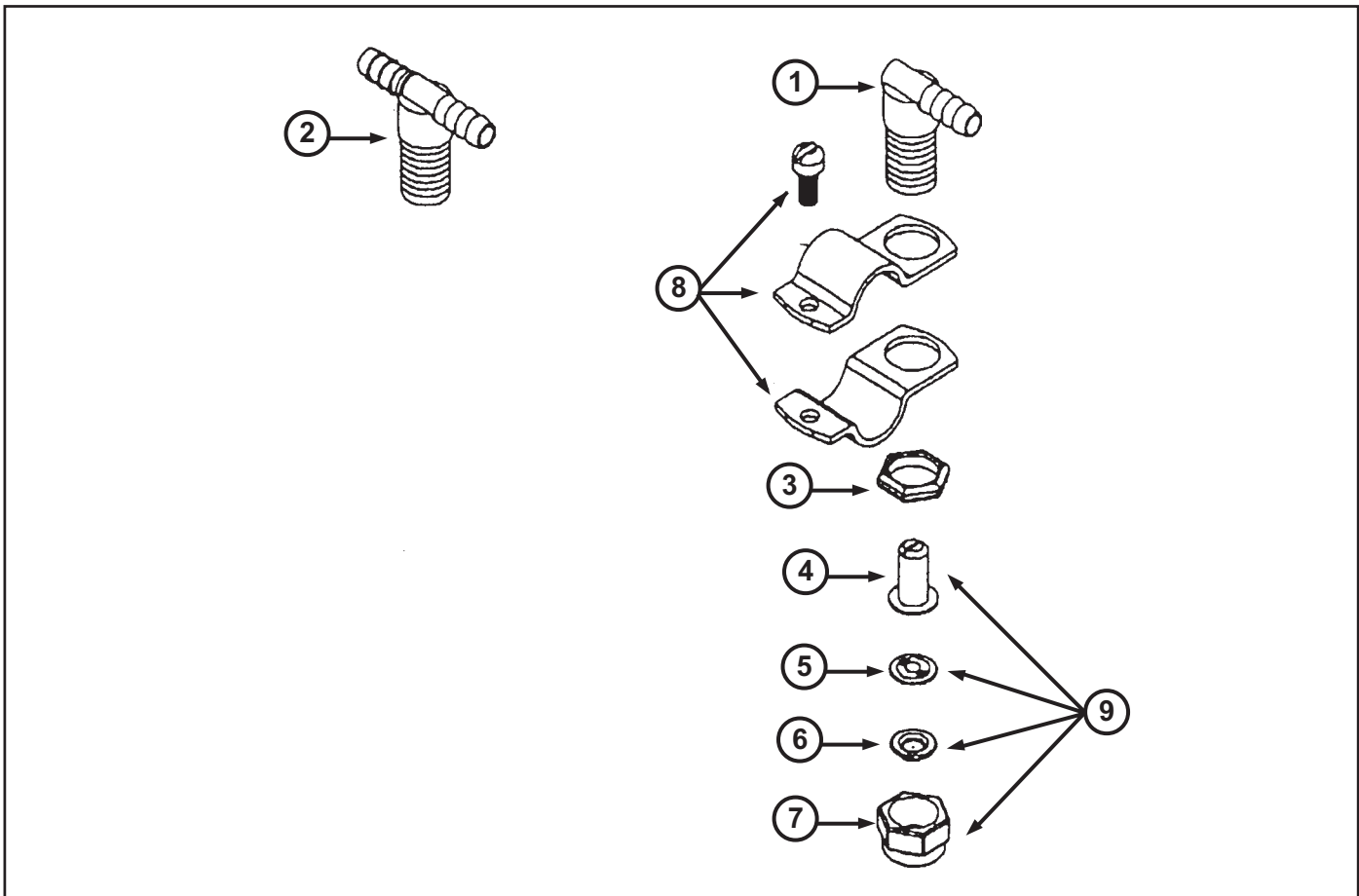

ITEM	PART NUMBER	DESCRIPTION	6' QTY.	8' QTY.
1	38161	90° Degree Water Fitting	2	2
2	38160	Tee Brass Water Fitting	4	6
3		Nut, Comes on Part 38160 & 38161	6	8
4	38159	Check Valve Strainer	6	8
5	38164	Brass Seal	6	8
6	38158	Water Spray Orifice	6	8
7	38157	Brass Cap	6	8
8	38162	Spray Bar Clamp W/Screw	6	8
9	38908	Spray Kit Items 4,5,6,7	6	8

Brush Core

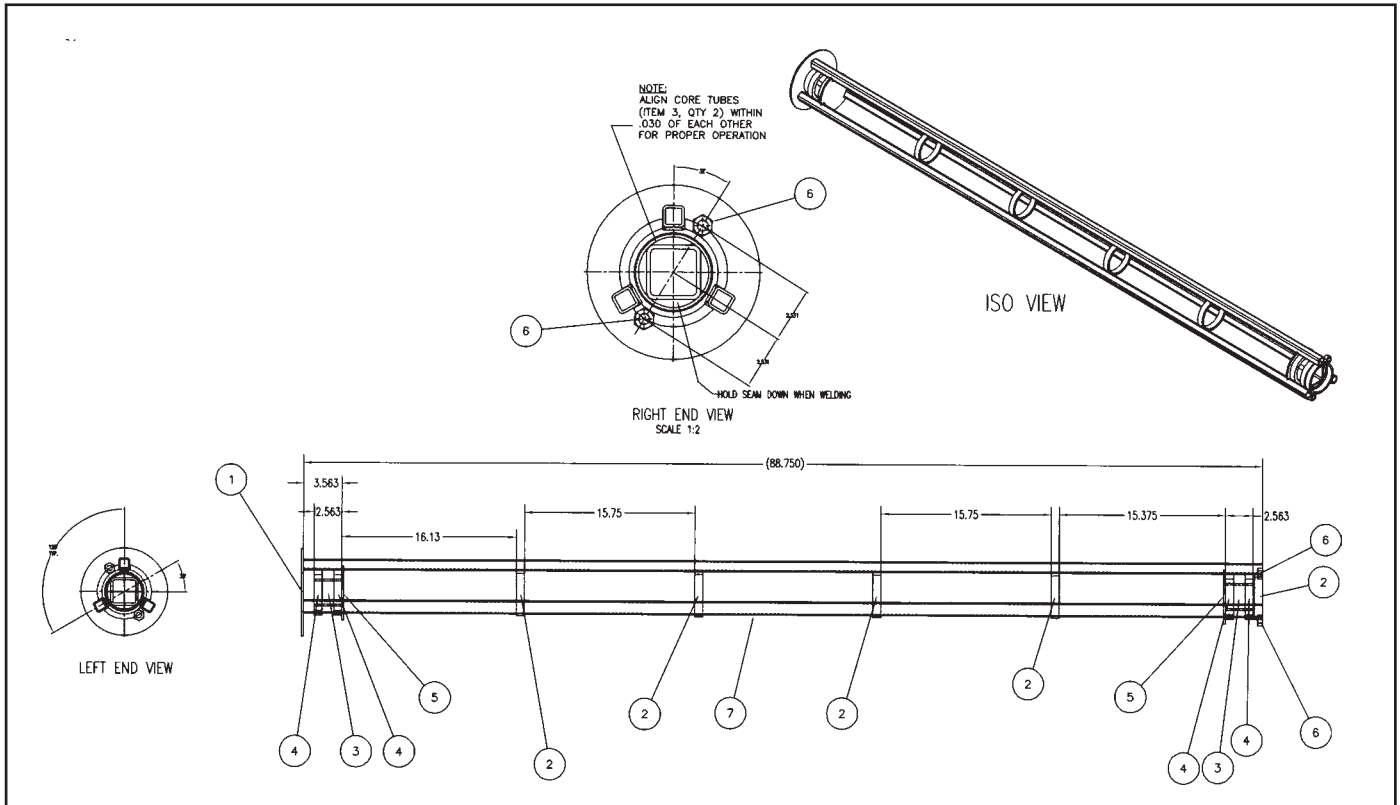

ITEM	PART NUMBER	DESCRIPTION	QTY.
1	38330	Plate, Broom Core End	2
2	38327	Rings, Thin Broom Core Center	5
3	38603	Tube - Broom Core	5
4	38326	Rings, Thick Broom Core	2
5	38672	Plate - Broom Core Cap	1
6	38620	Nut - 1/2 - 13 Heavy Hex	1
7	38324	Tube, Broom, Core, 8'	1

Parts

Front Hub

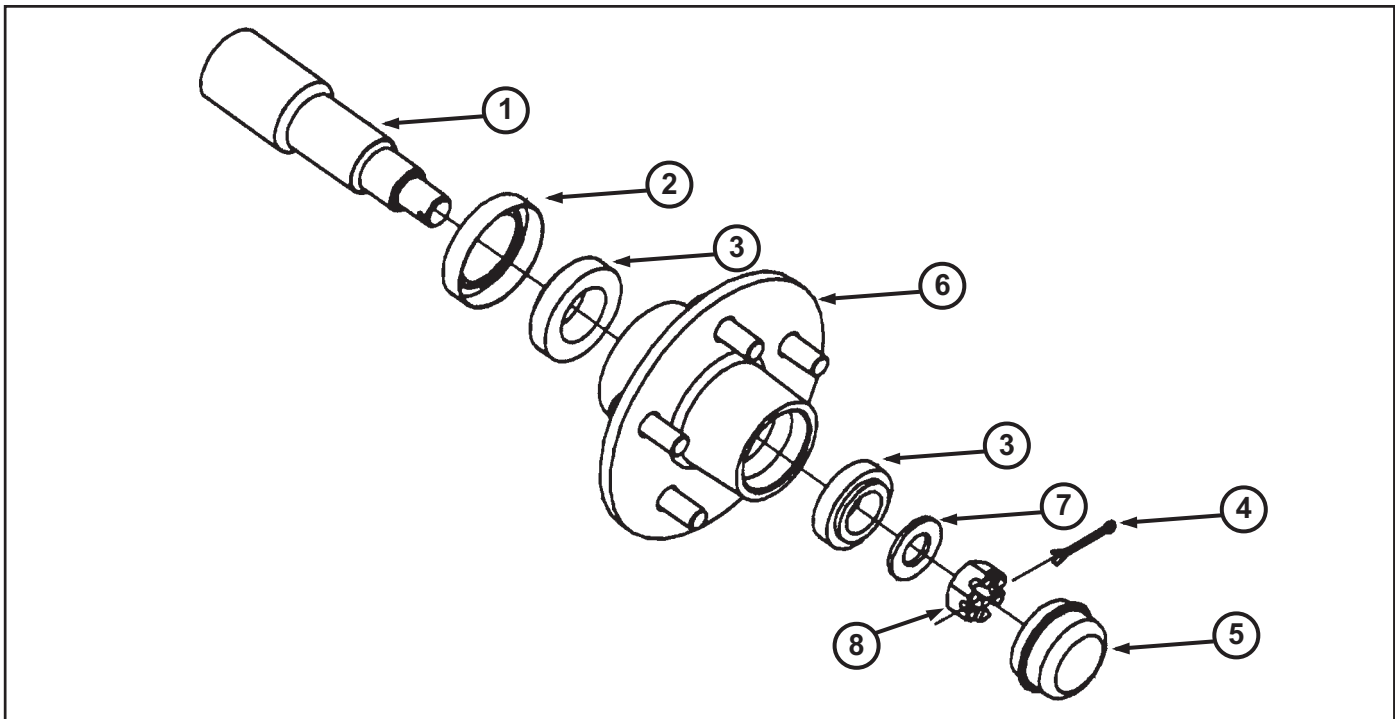

Old, Prior To Ser#23TS0327

ITEM	PART NUMBER	DESCRIPTION	QTY.
1	38141	Spindle, P/N	1
2	38914	Rings, Thin Broom Core Center - Seal Sold Separately	1
3	38484	Bearing/Race FR Hub	2
4	53160	Cotter Pin 1/8" x 1 3/4"	1
5	38485	Dust Cap	1
6		Hub, Not Sold Separately	1
7	28015	Washer, P/N, 1" SAE	1
8	28016	Slotted Nut, P/N, 1" - 14	1
9	38047	Kit P/N Contains Bearings, Hub and Dust Cap	1

New, After Ser#23TS0327

ITEM	PART NUMBER	DESCRIPTION	QTY.
1	38850	Spindle, P/N	1
2	38863	Seal	1
3	53123	Bearing, FR Inner	1
4	53125	Bearing, FR Outer	1
5	53160	Cotter Pin 1/8" x 1 3/4"	1
6	53170	Dust Cap	1
7	53137	Hub	1
8	53140	Washer, P 3/4" SAE	1
9	53150	Slotted Nut, P/N 3/4"	1
10	38864	Kit P/N Contains Bearings, Hub and Dust Cap	1

Pivot Bearing Weldment Assembly

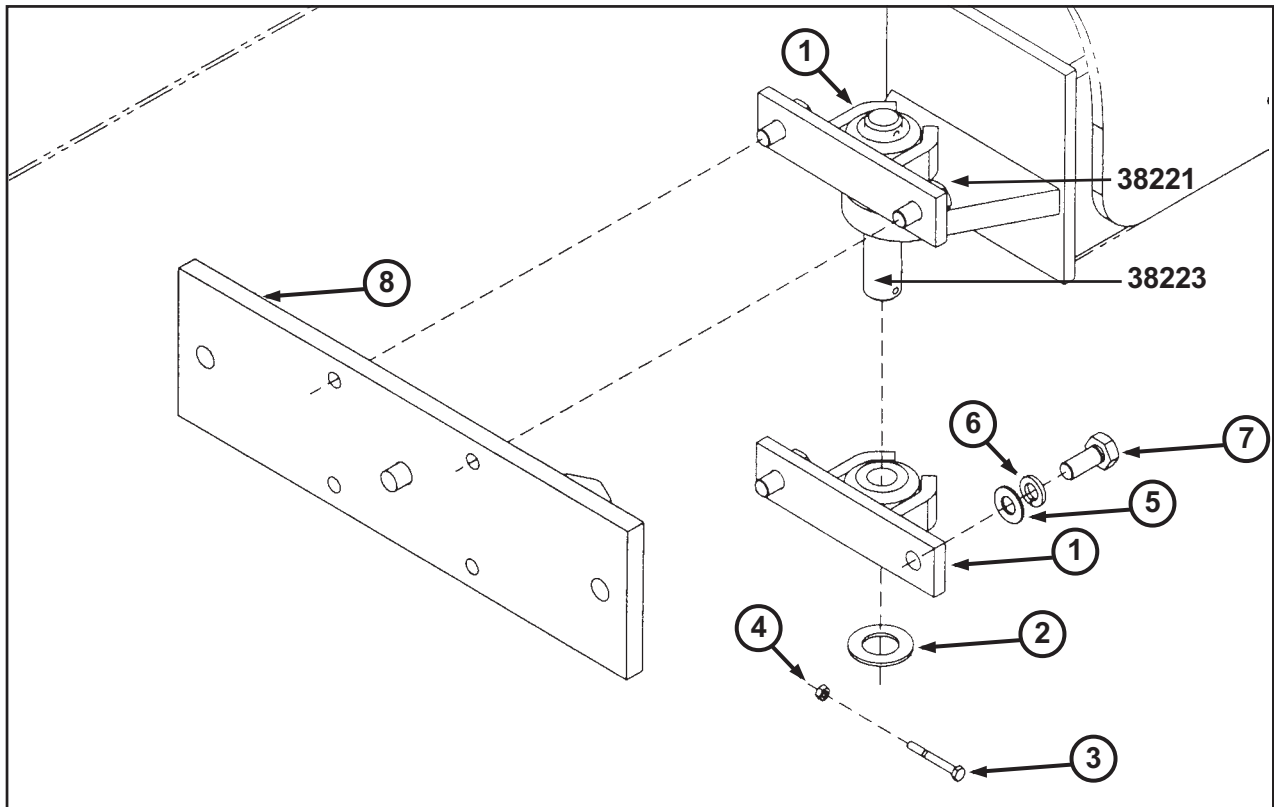

ITEM	PART NUMBER	DESCRIPTION	QTY.
1	38314	Pivot Bearing Weldment	2
2	22175	1 1/4" Washer	1
3	22150	1/4" - 20 x 2 1/4" Bolt	1
4	22171	1/4" Lock Nut	1
5	28047	5/8" Flat Washer	4
6	22162	5/8" Lock Washer	4
7	22214	5/8" - 18 x 1 1/2" Bolt	4
8	38346	Pivot Bracket Weldment	1

Parts

Broom Mount Weldment

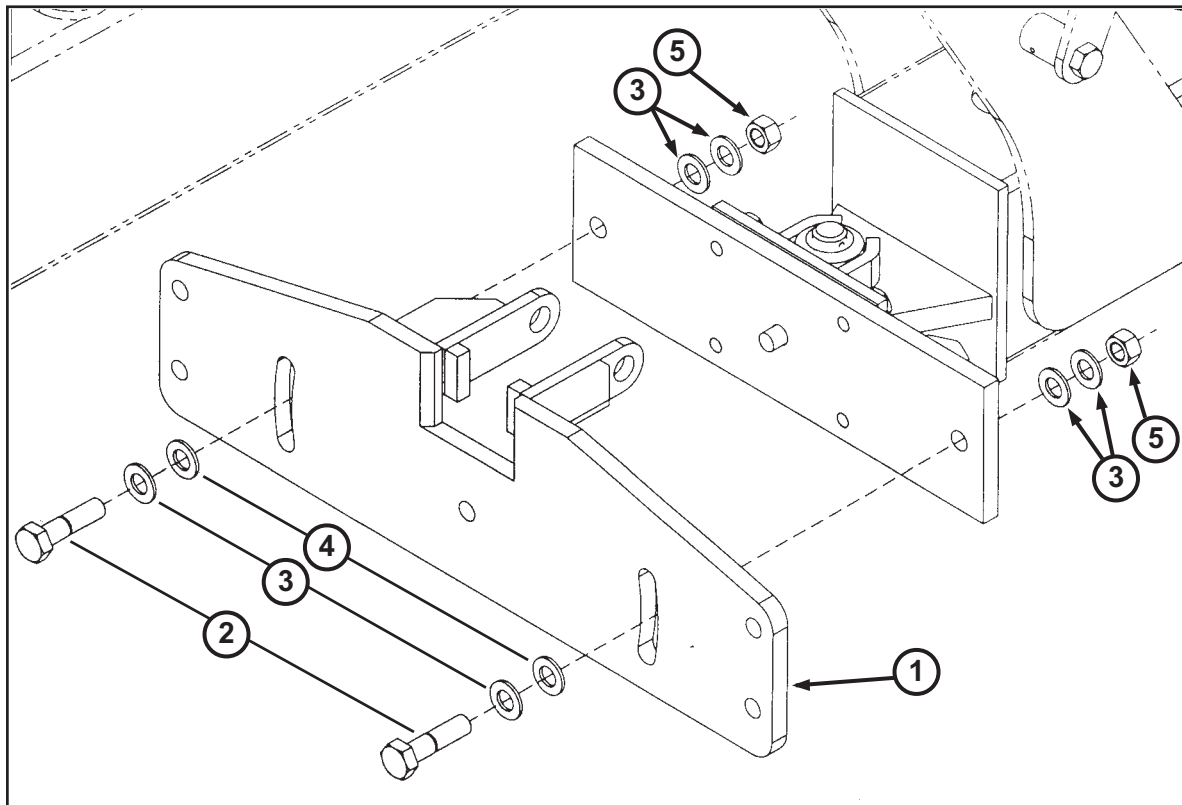

ITEM	PART NUMBER	DESCRIPTION	QTY.
1	38313	Broom Mount Plate W/Stops	1
2	28030	3/4" - 10 x 3" Bolt	2
3	53140	3/4" Flat Washer SAE	6
4	28060	3/4" Flat Washer USS	2
5	28037	3/4" Lock Nut	2

Brush Bar Assembly

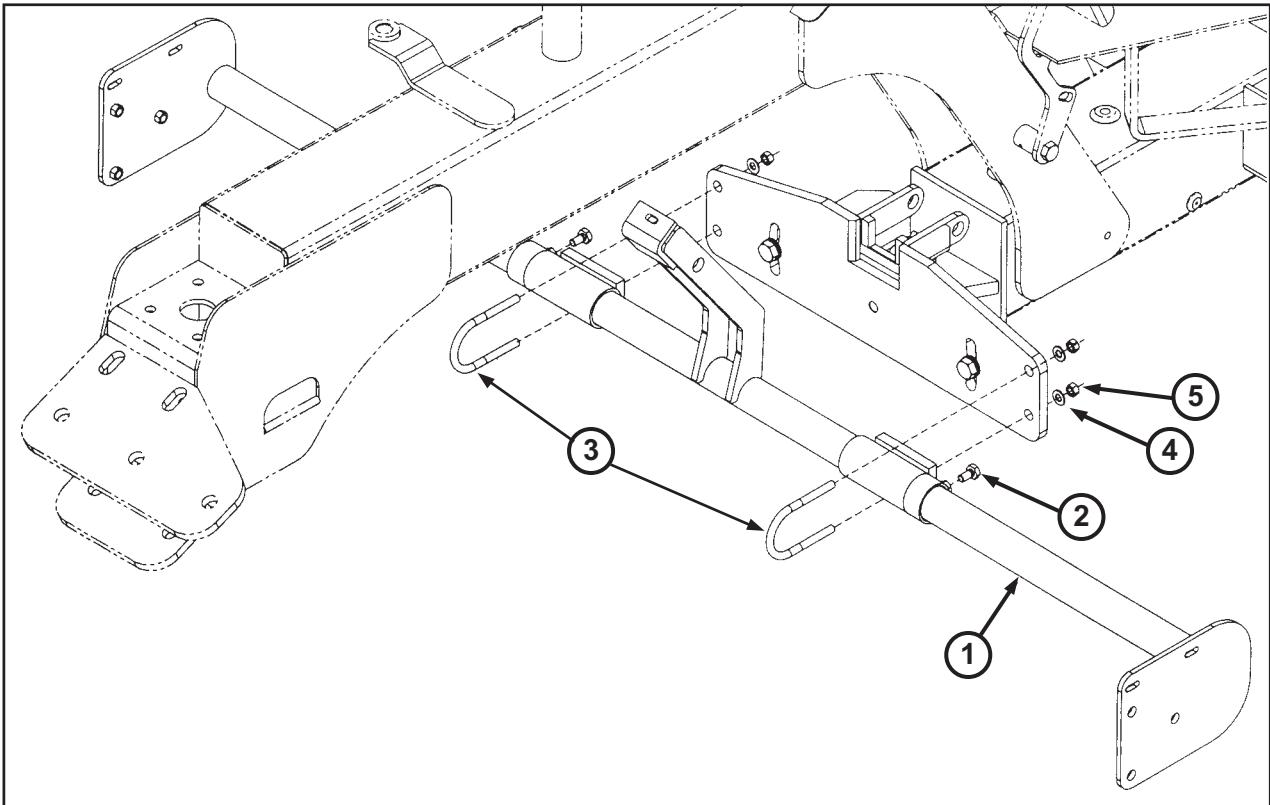

ITEM	PART NUMBER	DESCRIPTION	QTY.
1	38306	6' Brush Mount Bar	1
	38307	8' Brush Mount Bar	1
2	28019	1/2" - 13 x 1" Bolt	2
3	22168	1/2" x 3" x 6" U-Bolt	2
4	28042	1/2" Flat Washer SAE	4
5	28059	1/2" - 20 Lock Nut	4

Parts

Brush Bar Cylinder

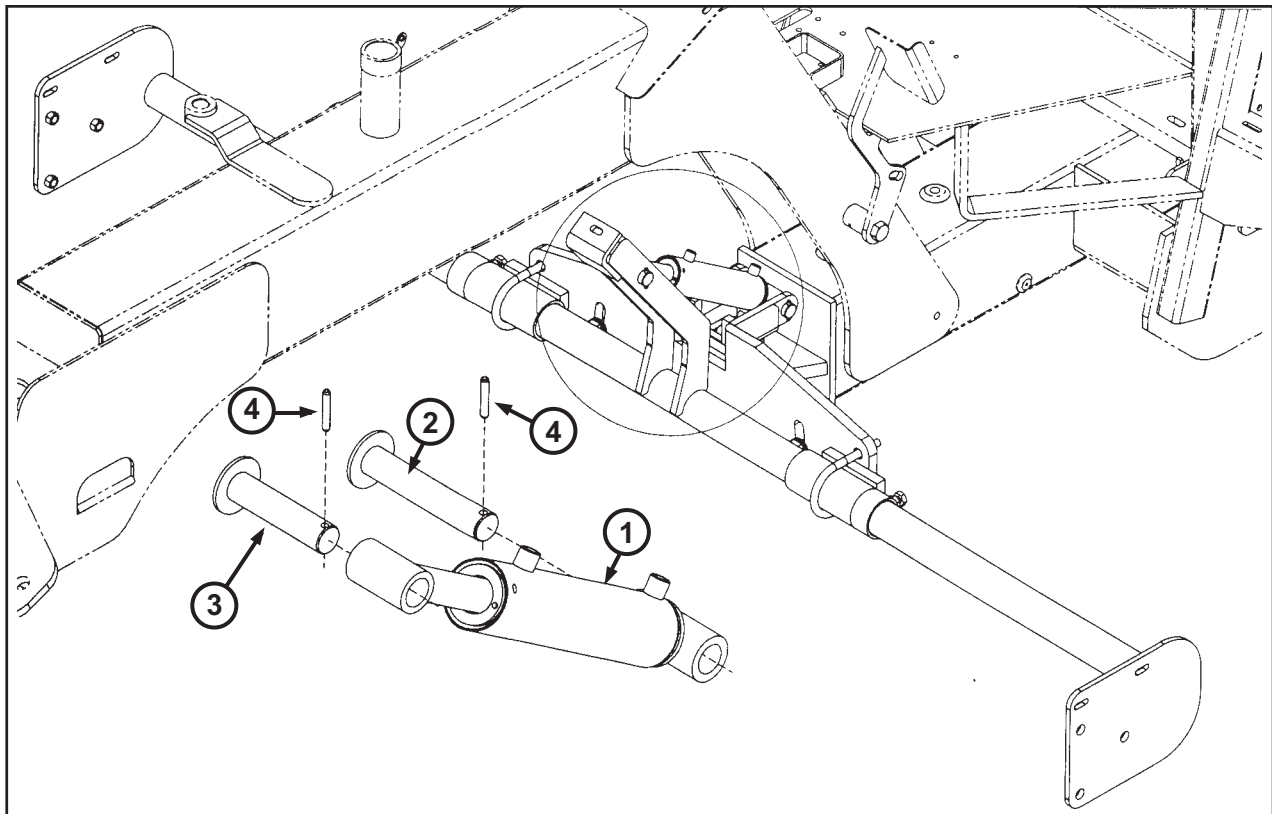

ITEM	PART NUMBER	DESCRIPTION	QTY.
1	38016	Brush Lift Cylinder	1
2	38421	1" Dia. x 5 1/8 Long Pin	1
3	38422	1" Dia. x 4 1/8" Long Pin	1
4	28042	1/4" x 1 1/2" Long Roll Pin	2

Brush Core Motor Mount

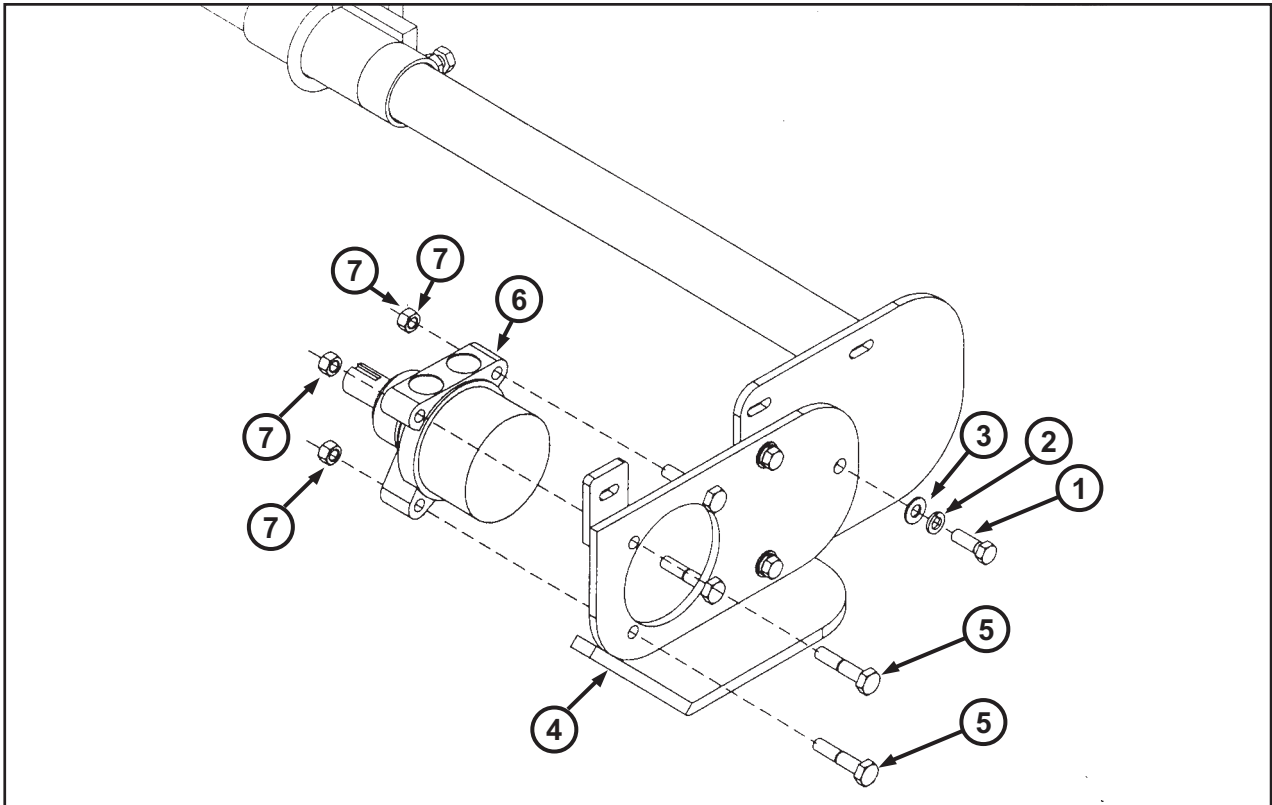

ITEM	PART NUMBER	DESCRIPTION	QTY.
1	22037	1/2" - 13 x 1 1/2" Bolt	6
2	24013	1/2" Lock Washer	6
3	28042	1/2" Flat Washer SAE	6
4	38402	Brush Core Motor Mount, LH	1
	38403	Brush Core Motor Mount, RH	1
5	22146	1/2" - 13 x 2 1/2" Bolt	8
6	38052	Brush Core Motor	2
7	28500	1/2" Lock Nut	8

Parts

Brush Core Plate & Block For Motor Assembly

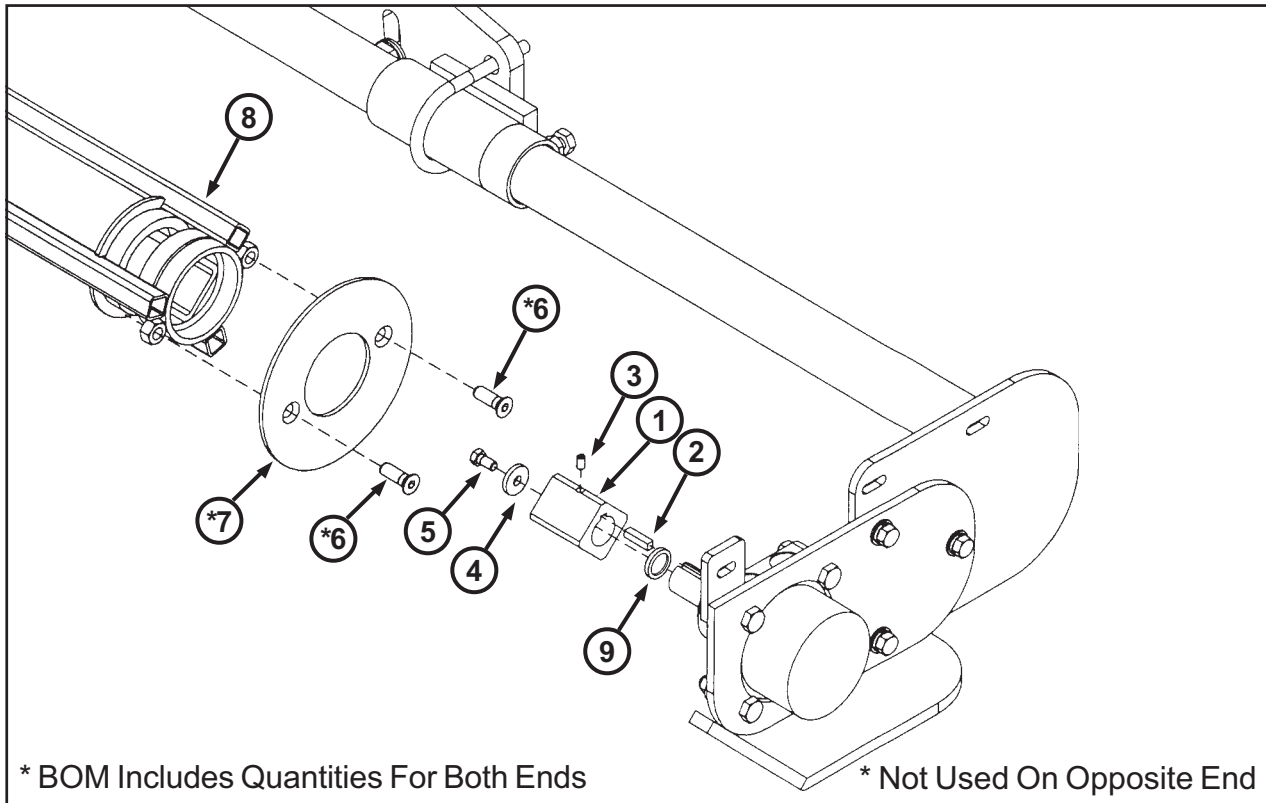

ITEM	PART NUMBER	DESCRIPTION	QTY.
1	38315	Drive Motor Block	2
2	38809	Straight Key	2
3	22115	5/16" - 18 x 1/2" Set Screw	2
4	38428	Key Retainer Washer	2
5	22044	3/8" x 3/4" Bolt	2
6	22167	1/2" x 1 1/4" Flat Head Bolt	2
7	38329	Brush Core Cap Plate	1
8	38308	6' Brush Core	1
	38309	8' Brush Core	1
9	38432	Block Seal for Brush Motor	1

Spray Bar Assembly

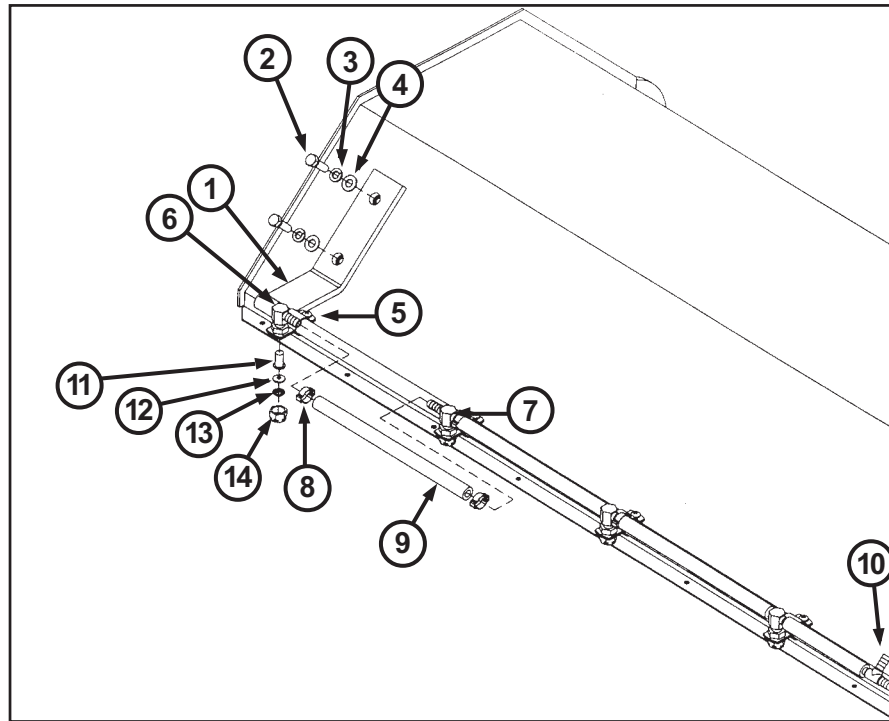

ITEM	PART NUMBER	DESCRIPTION	QTY.
1	38304	6' Spray Bar	1
	38305	8' Spray Bar	1
2	22123	3/8" - 16 x 1 1/4" Bolt, Zinc Plated	4
3	22171	3/8" Lock Washer	4
4	28044	3/8" Flat Washer	4
5	38162	Spray Bar Clamp W/Screw	8
6	38161	90° Brass Water Fitting	2
7	38160	Tee Brass Water Fitting	6
8	38176	Spray Hose Clamp	16
9	38387	3/8" Spray Hose (6 - 10 1/2", 2 - 4 1/2")	6 ft.
10	20135	3/8" Barbed Tee Water Fitting	1
11	38159	Check Valve Strainer	8
12	38164	Brass Seal	8
13	38158	Water Spray Orifice	8
14	38157	Brass Cap	8

Parts

Brake Hub Assembly

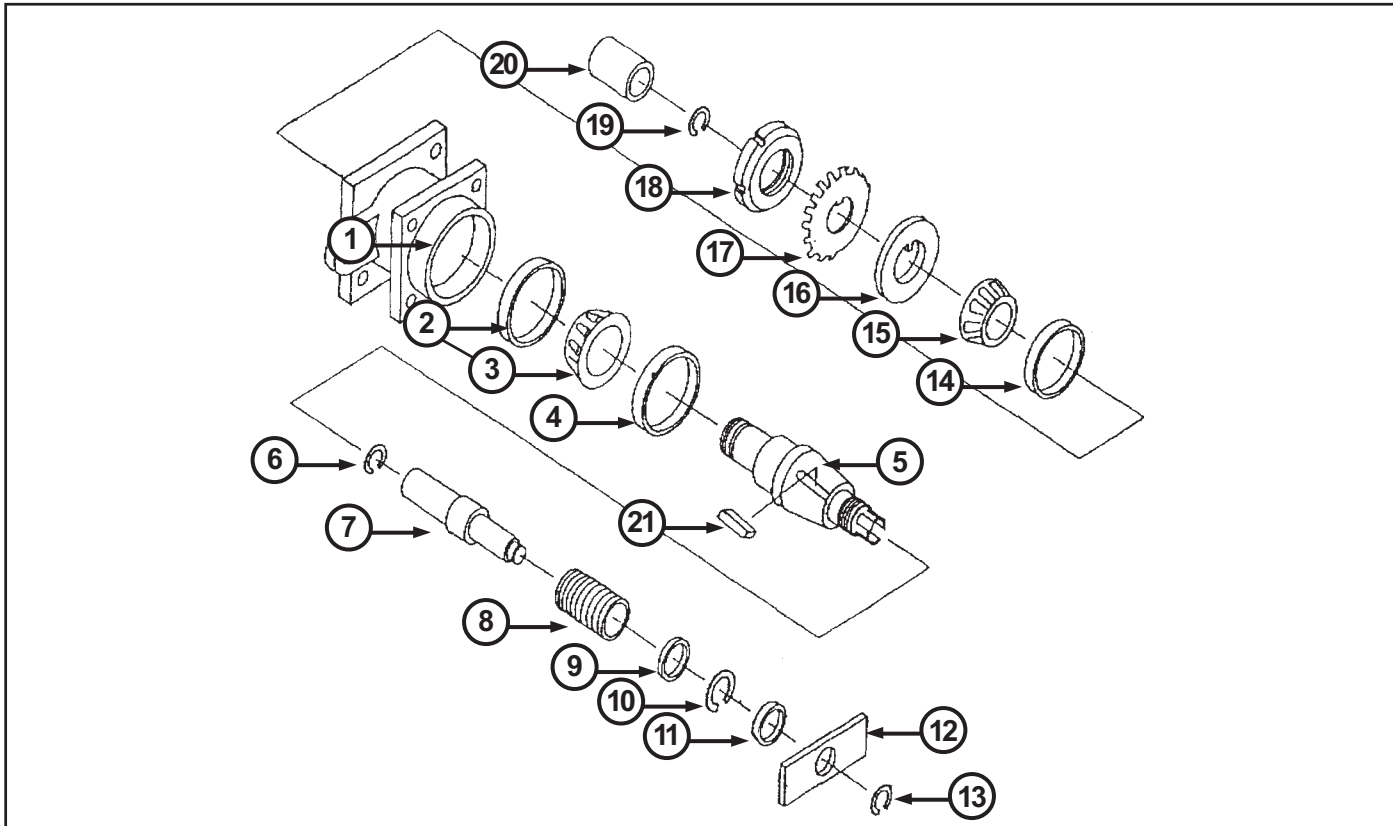

ITEM	PART NUMBER	LAKIN#	DESCRIPTION	QTY.
1	N/A	4207	Housing w/Brake	1
2	38776	3732	Set, Bearing & Race, Outer #2 & #3	1
3	38776	3731	Set, Bearing & Race, Outer #2 & #3	1
4	38775	3728	Seal, Oil - Bearing	1
5	38828	3718	Spindle, Brake, Disconnect Hub	1
6	N/A	3724	Ret. Ring - Shaft (2) req'd	1
7	N/A	3719	Shaft	1
8	38424	3735	Spring, Shaft	1
9	38845	3736	Washer, Spring	1
10	N/A	3725	Ret. Ring - Spring	1
11	38843	3727	Seal, Oil, Shaft	1
12	N/A	3721	Handle, Shaft	1
13	N/A	3726	Ret. Ring - Handle	1
14	38777	3730	Set, Bearing & Race, Inner #14 & #15	1
15	38777	3729	Set, Bearing & Race, Inner #14 & #15	1
16	38839	3976W	Washer, Tongued	1
17	38827	3734	Lockwasher, Inner	1
18	38826	3733	Locknut (2) req'd	1
19	N/A	3723	Ret. Ring - Sleeve	1
20	38823	3720	Sleeve, Brake Disconnect Hub	1
21	N/A	3990	Key, 0.312 sq. x 1" Long	1

Brake Hub Assembly

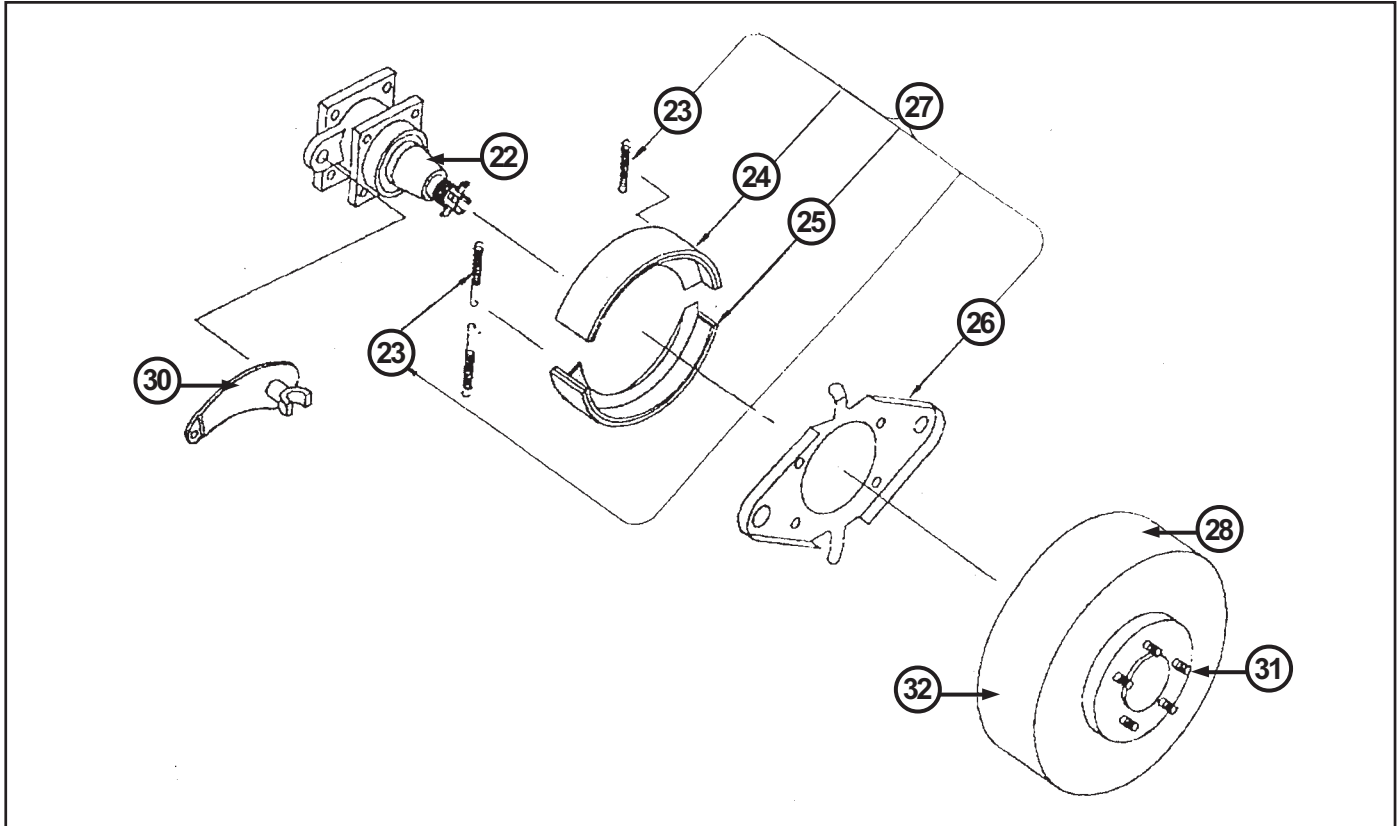

ITEM	PART NUMBER	LAKIN#	DESCRIPTION	QTY.
22	N/A	3573	Basic Hypac	1
23	N/A	3713	Spring (4) req'ed (Only shipped complete w/27.)	1
24	N/A	N/A	Brake Shoe (Only shipped complete w/27.)	1
25	N/A	N/A	Brake Shoe (Only shipped complete w/27.)	1
26	N/A	N/A	Backing Plate (Only shipped complete w/27.)	1
27	N/A	3700	Brake Shoe Assembly	1
28	N/A	4314	Hub - Drum	1
29	N/A	N/A	Spring (2) req'ed	1
30	N/A	3701	Brake Arm Shaft Assembly	1
31	N/A	3709	Bolt, Wheel Hub (5) req'ed	1
32	N/A	4188	Steel Drum	1
			Not Shown in Drawings	1
5.1.	N/A	N/A	Spindle, Brake Disconnect (Used)	1
17.1	38777	N/A	Lockwasher, Inner (Used)	1
18.1	38777	N/A	Locknut (2) req'ed (Used)	1
52	38050	N/A	Gasket, Face Seal "A" Mount 4 Bolt	1
53.	38085	3823A	Assembly, Brake / Disconnect Hub	1
54.	38486	4107A	Wrench, Hypac hub Mount Nut	1

Not Sold Separately

Parts

Hoses Set Sweeper Parker Valves

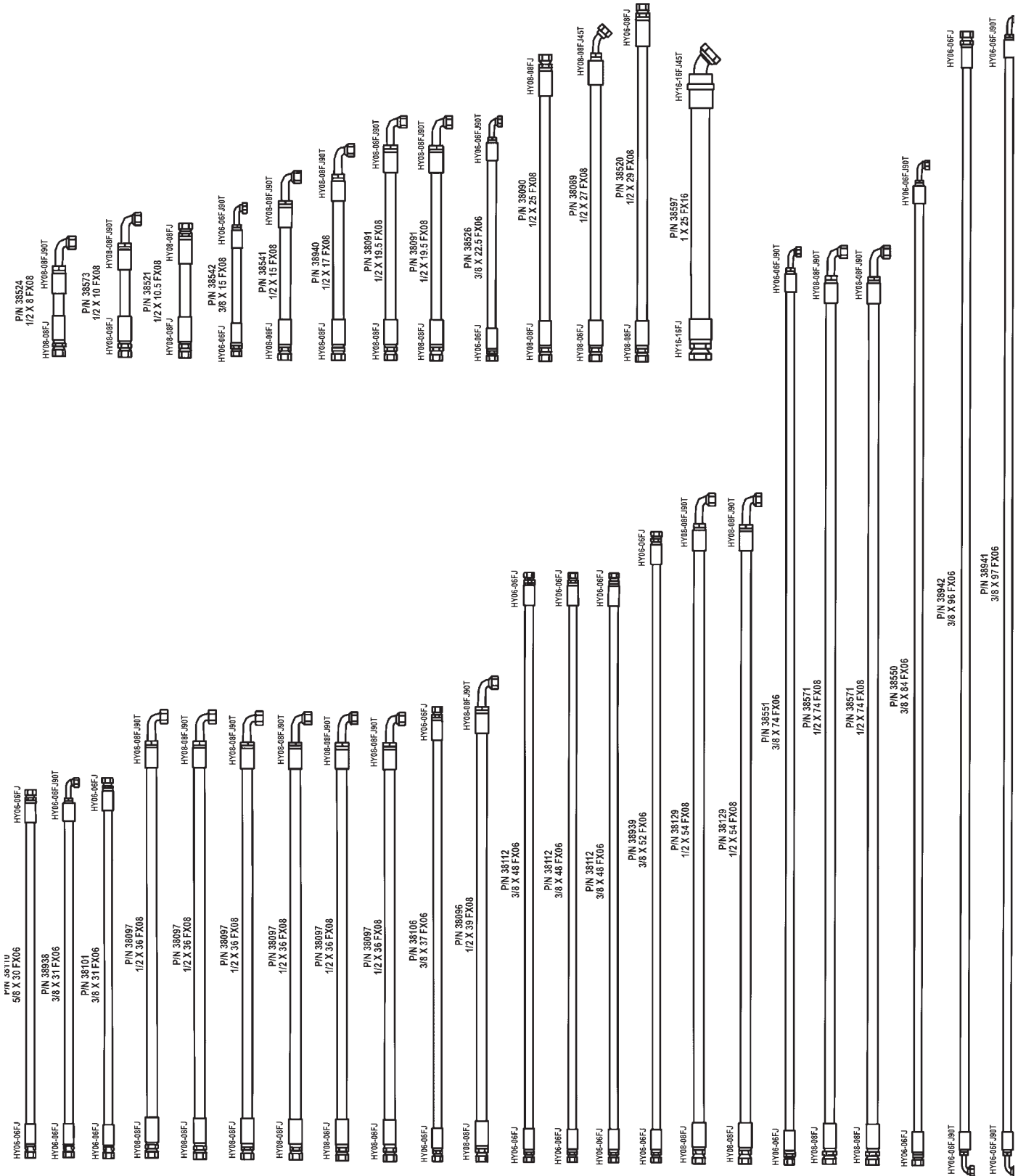

Hoses Set Sweeper Saver Dantoss Valves

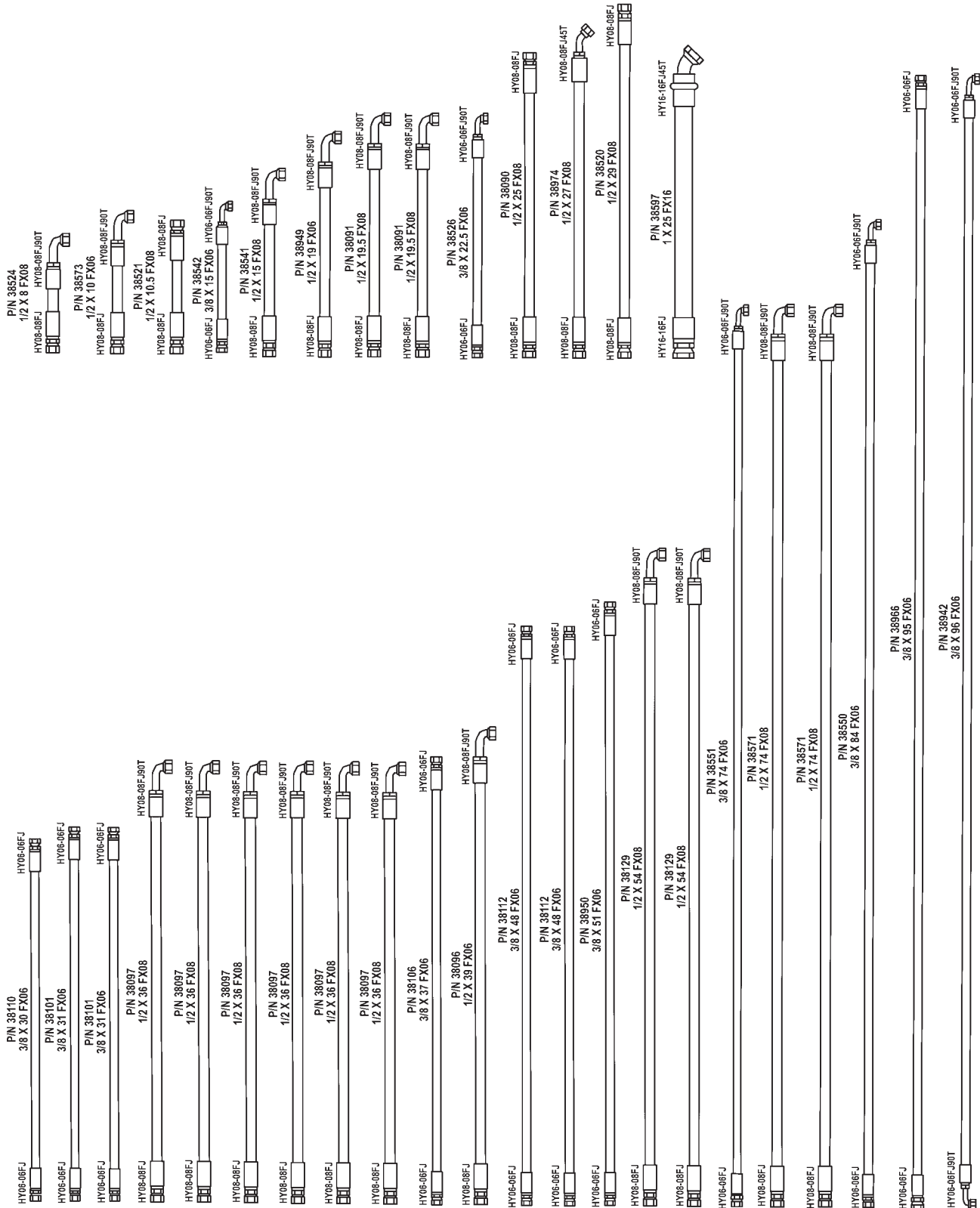

Parts

Hoses 6 Ft. Sweeper

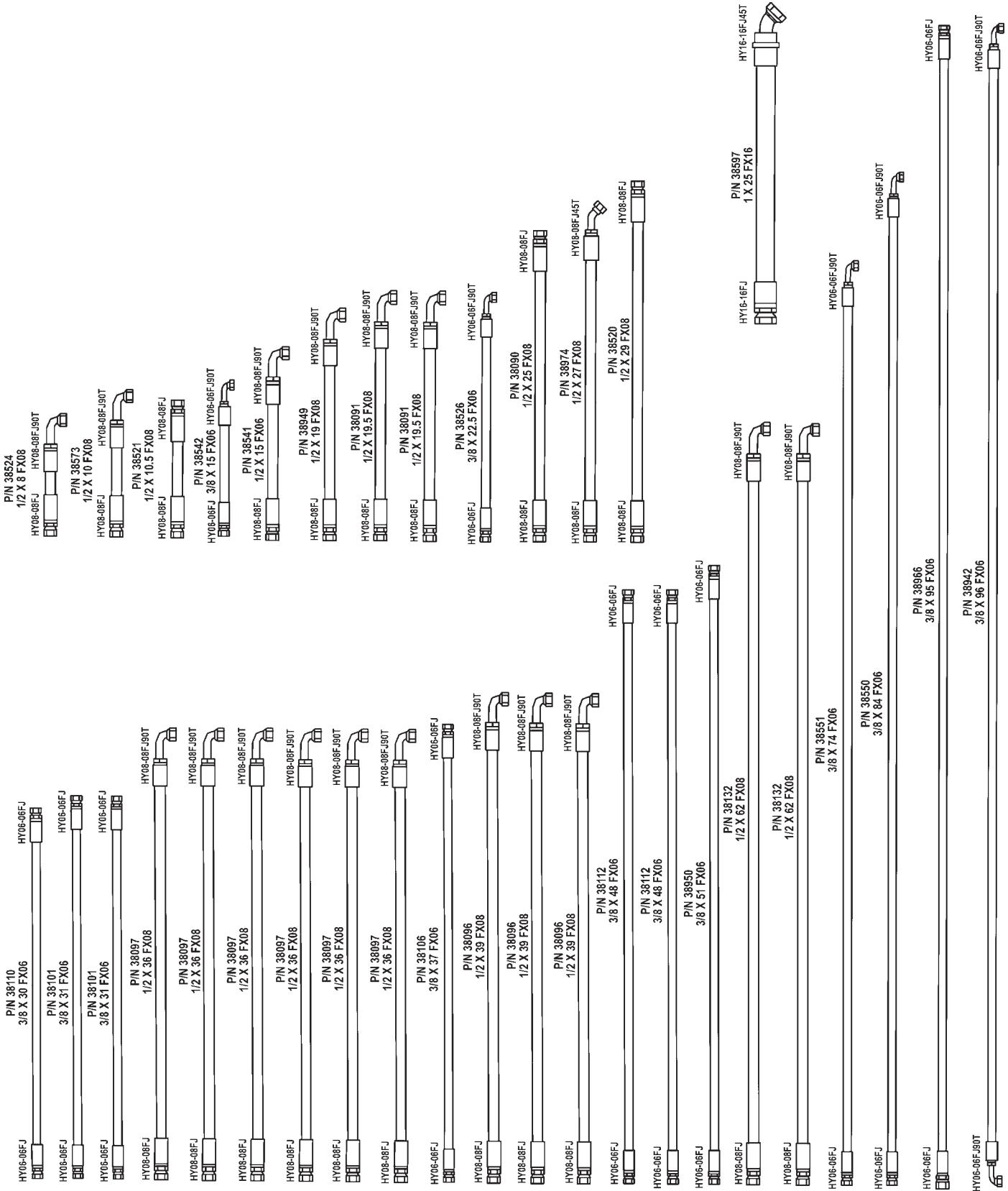

Low Pressure Filter Assembly

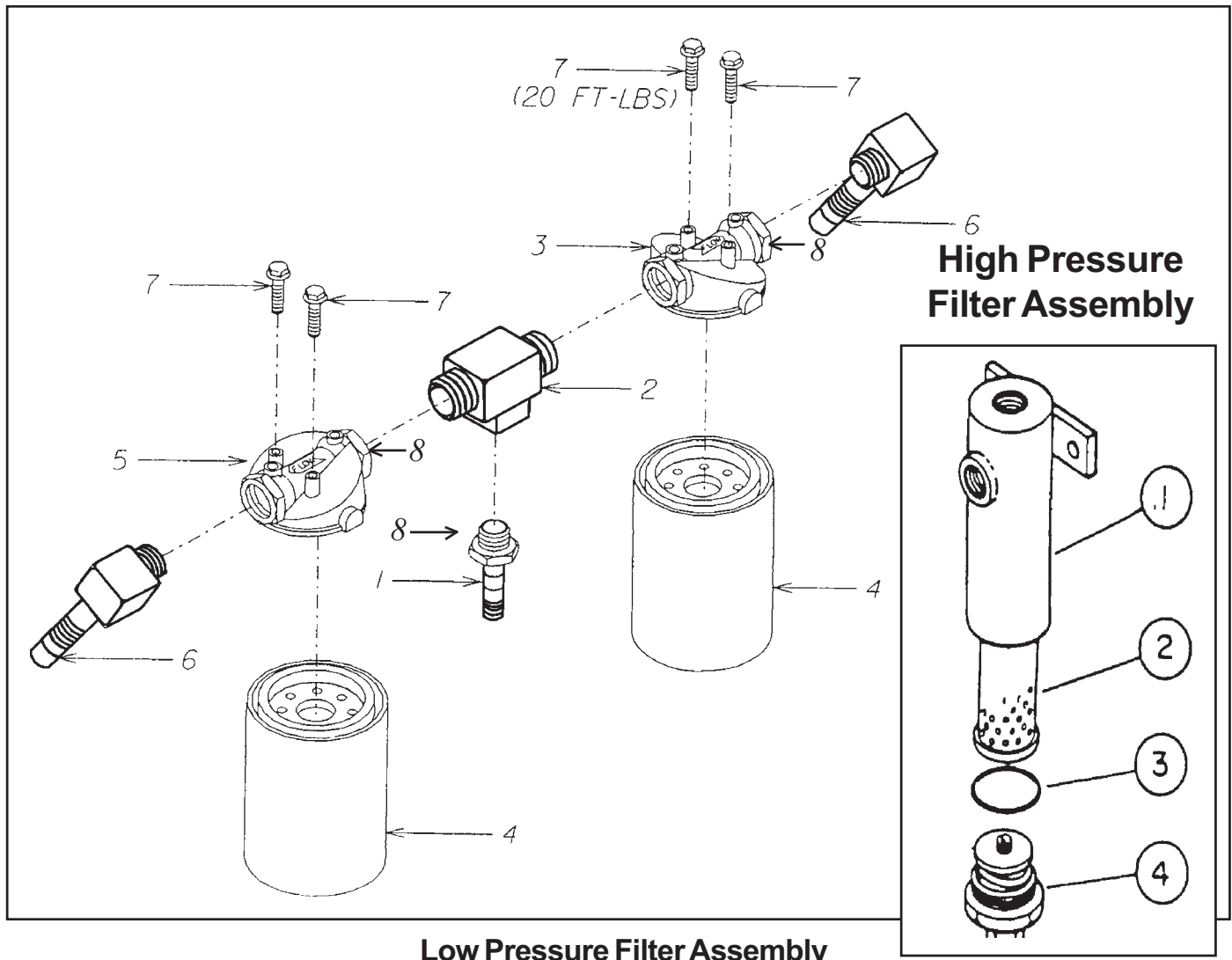

Low Pressure Filter Assembly

ITEM	PART NUMBER	DESCRIPTION	QTY.
1	20123	Fitting, #8MVIC x #8MP Straight	1
2	20163	Fitting, T, 3/4" mp Across 3/4 FP Center	1
3	38074	Filter Base	1
4	21002	Filter Hydraulic, T5C/Sweeper	2
5	38075	Filter Base	1
6	20172	Fitting 1/2 mp x #8MVIC 90°	2
7	22192	Bolt 1/4" - 20 x 5/8 GR8Z	4
8	20128	Fitting 3/4" mp x 1/2 F Reducer	3

High Pressure Filter Assembly

ITEM	PART NUMBER	DESCRIPTION	QTY.
1	38073	Filter, Housing Assembly	1
2	38297	Filter, Element Internal	1
3		Filter, O-Ring, Not Sold Separately	1
4		Filter, Relief Nut Assembly, Not Sold Separately	1

Parts

Ground Drive Assembly

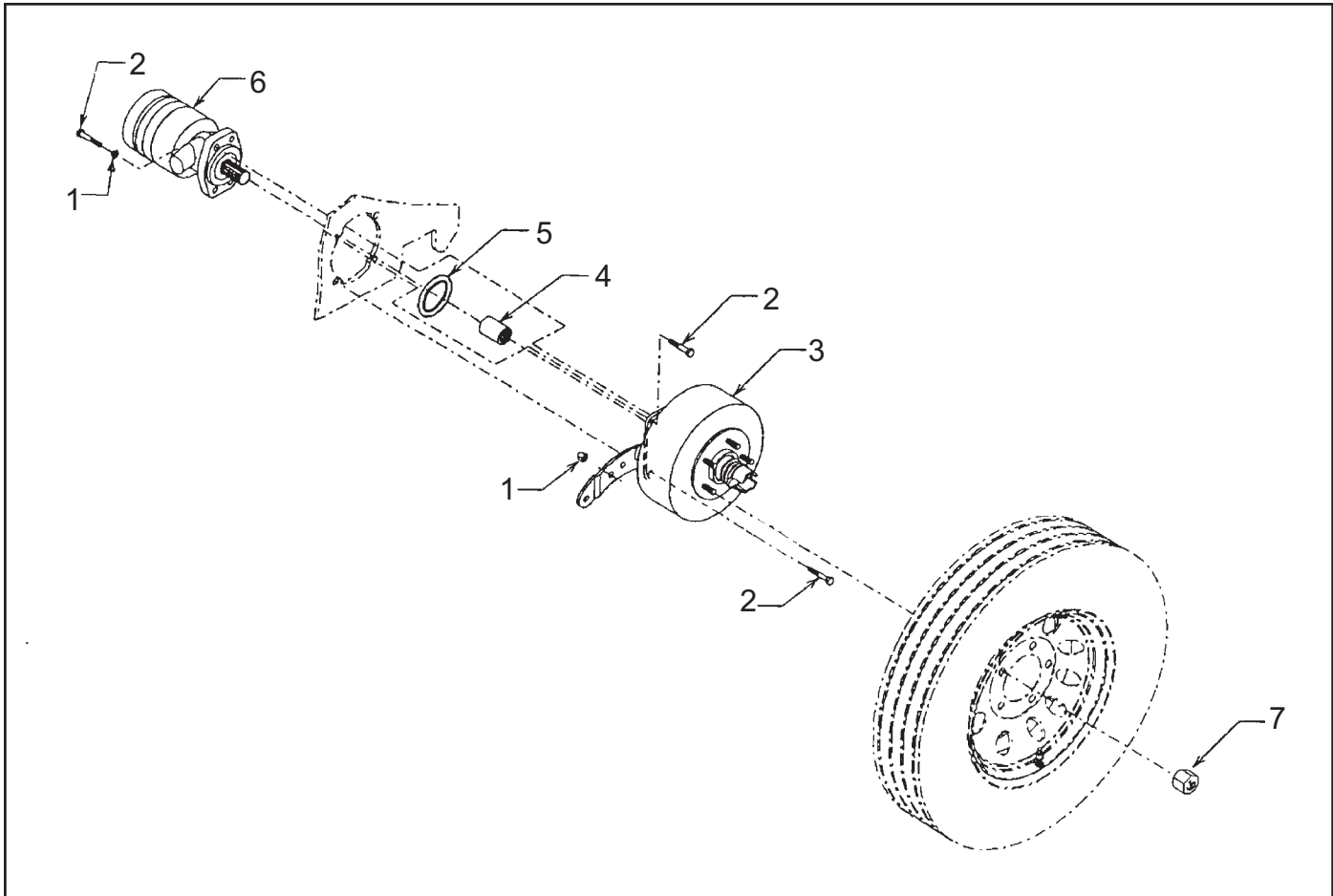

ITEM	PART NUMBER	DESCRIPTION	QTY.
1	24013	Washer, 1/2", Split Lock	4
2	22155	Bolt, 1/2"-20 x 1/2" GR8	4
3	38085	Brake Hub Assembly	1
4	38823	Sleeve, Brake Disconnect Hub	1
5	38050	Gasket, Motor-to/Lockout, Wheel Drive	1
6	38867	Motor, Drive, Wheel, W/Relief, After Ser#24TS0107	1
7	28506	Nut, Lug, 1/2" ID x 13/16" on, Front/Rear	5

Gear Pump Part Number 66000 Gas / 66001 Diesel

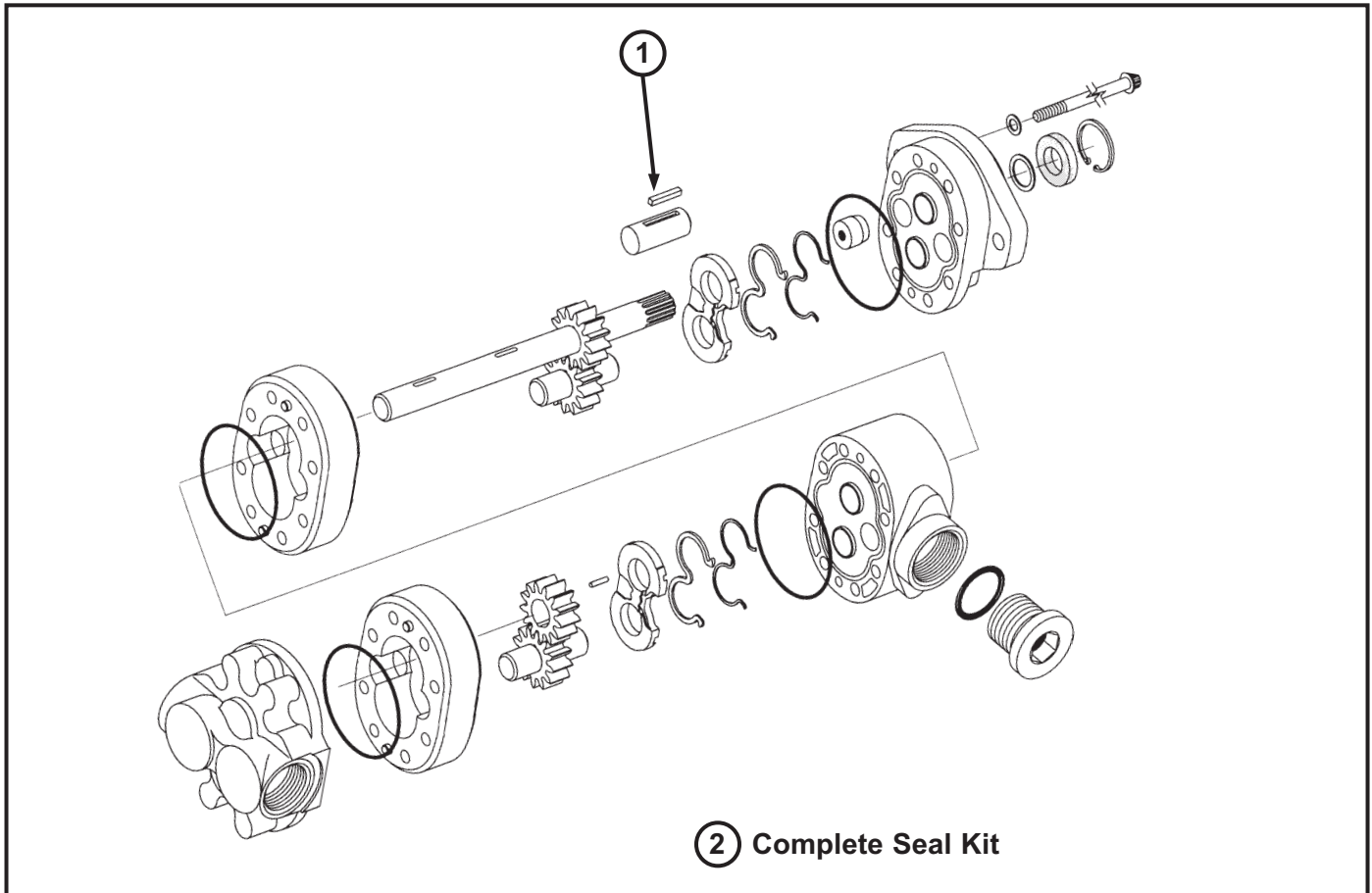

ITEM	PART NUMBER	DESCRIPTION	QTY.
1	64049	Key, Coupler, Cessna	1
2	66030	Kit, Seal, Double Gear Pump	1

Parts

Hydrastatic Transmission

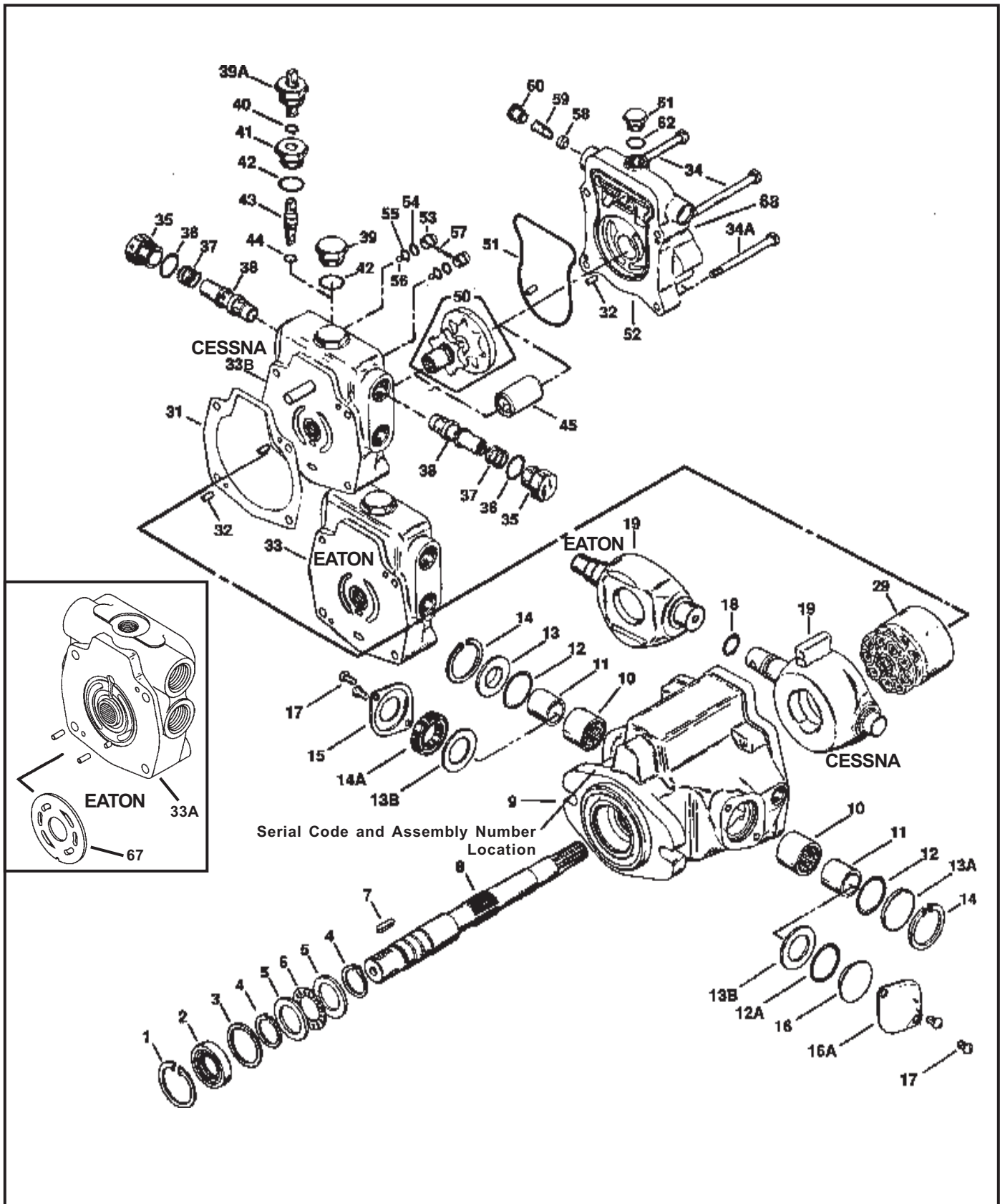

*PLEASE PROVIDE SERIAL NUMBER OF MACHINE WHEN ORDERING ANY COMPONENT PARTS.

ITEM	PART NUMBER	DESCRIPTION	QTY.
1	60401	Retaining Ring	1
2	60402	Shaft Seal	1
3	60403	Washer	1
4	60404	Retaining Ring	2
5	60405	Bearing Race	2
6	60406	Bearing, Thrust	1
7	60471	Key	1
8	38892	Drive Shaft	1
9	60409	Housing Assembly	1
10	60410	Bearing	2
11	60411	Inner Race	2
12	60412	O-Ring, 3/32" x 15/16", Outer Pintle	2
13	60465	Sleeve Cover	1
13A	60415	Trunnion Cover	1
13B	60561	Washer	1
14	60414	Retaining Ring	2
14A	60562	Seal, Pintle	1
15	60418	Seal Cover	1
17	60564	Screws, Trunnion Cover	2
18	60516	O-Ring, Outer Pintle	1
19	60517	Camplate, For Eaton Trans.	1
19	60417	Camplate, For Cessna Trans.	1
29	60422	Rotating Kit Assembly	1
31	60429	Housing, Gasket	1
33	60533	Backplate Assy., Eaton, with Power Steering	1
33A	60535	Backplate Assy., w/valve plate, Eaton	1
33B	60432	Backplate Assy., Cessna, without Power Steering	1
35	60436	Plug Assembly	2
36	60435	O-Ring 3/32" x 7/8" ID, Back Plate	1
37	60463	Spring, Transmission, Relief Valve	2
38	60467	Relief Valve Assembly	2
39	60433	Plug Assembly	1
40	60440	Retaining Ring	1
41	60441	Separator Plug	1
42	60442	O-Ring, 3/32" x 7/8"	1
43	60454	Spreader	1
44	60437	O-Ring, 1/16" x 3/8"	1
45	60443	Coupler	1
50	64050	Gerotor and Coupler	1
51	60449	O-Ring, Molded	1
52	60453	Adapter Assembly without Power Steering	1
	60553	Adapter Assembly with Power Steering	
	64058	Adapter Assembly with Power Steering - Diesel	
53	60450	Check Valve Assembly	2
54	60452	Back Up Washer	2
55	60455	O-Ring, 1/16" x 7/16"	2
56	60456	Steel Ball	2
57	60457	Pin	2
58	60461	Poppet Filter Relief	1
59	60463	Spring	1
60	60560	Spring Retainer	1
61	60469	Plug Assembly	1
62	60466	O-Ring, 3/32" x 41/64"	1
64	60464	O-Ring, 1/16" x 3/4"	1
65	60465	Cover Plate	1
66	60459	Cap Screw	2
67	60534	Plate, Valve	1
*S	64100	Seal Repair Kit, Cessna	1
*S	64101	Seal Repair Kit Eaton	1
*S	60043	Rotating Rebuild Kit, Cessna	1
*S	60564	Screws, Trunnion Cover	2
68	60464	O-Ring in Back	1

Parts

110A Brush Motor Exploded View Parker

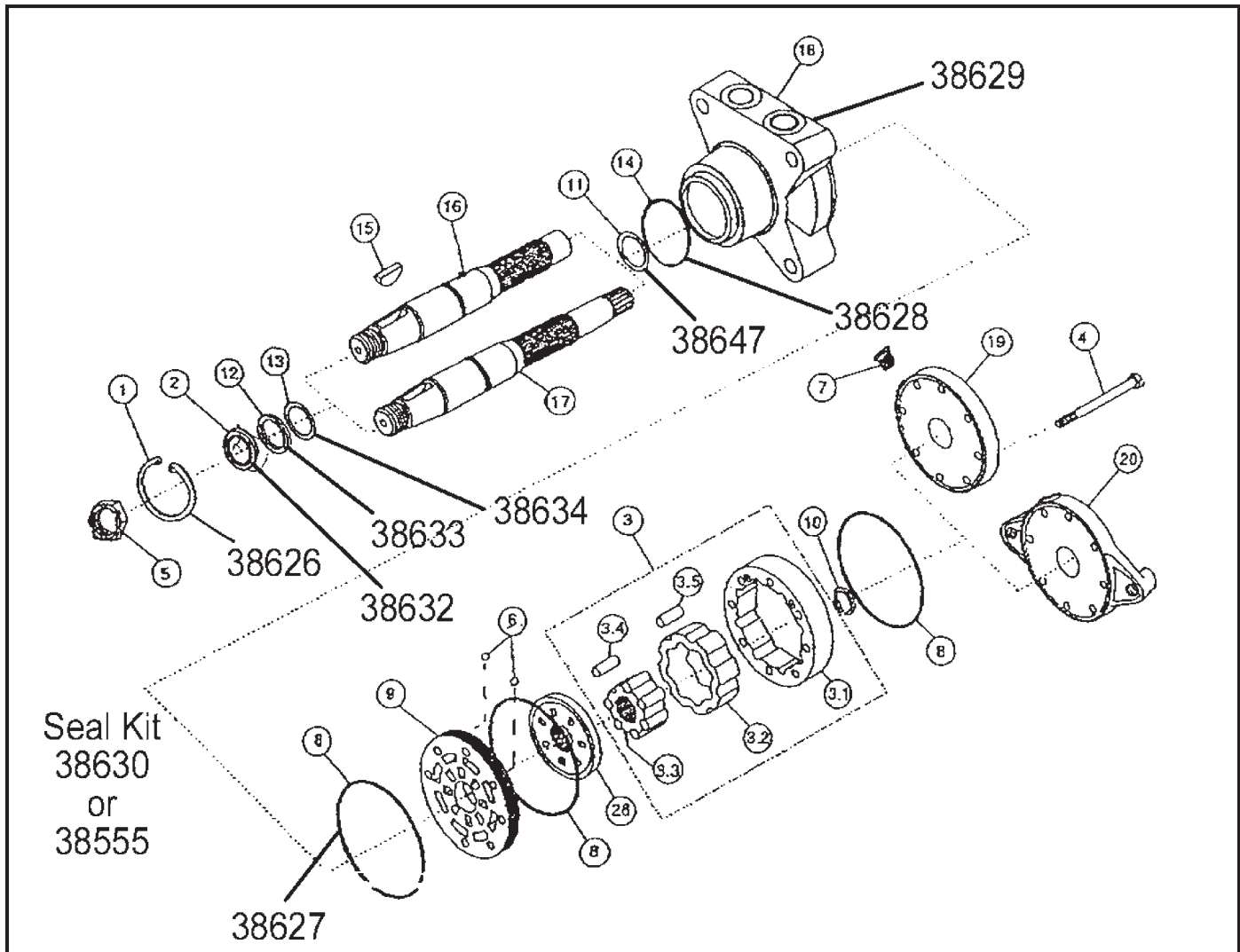

ITEM	PART NUMBER	DESCRIPTION	QTY.
1	38626	Ring, Snap, Seal, or Motor, Broom Core Parker	1
2	38627	Seal, Square Ring or Motor, Broom Core Parker	3
3	38632	Seal/Retainer Assembly, Broom Core Parker	1
4	38633	Washer, Thrust Drive Motor, Broom Core Parker	1
5	38634	Washer, Thrust Hard #13, Broom Core Parker	1
6	38647	Washer, Thrust #11, Broom Core Parker	1
7	38628	Seal, O-Ring, Drive Motor, Brush, Broom Core Parker	1
8	38629	Body, 4 Bolt Thru Mounting, Broom Core Parker	1
9	38630	Seal Kit, Drive Motor, Brush, Broom Core Parker	1

Kubota Engine Left Side

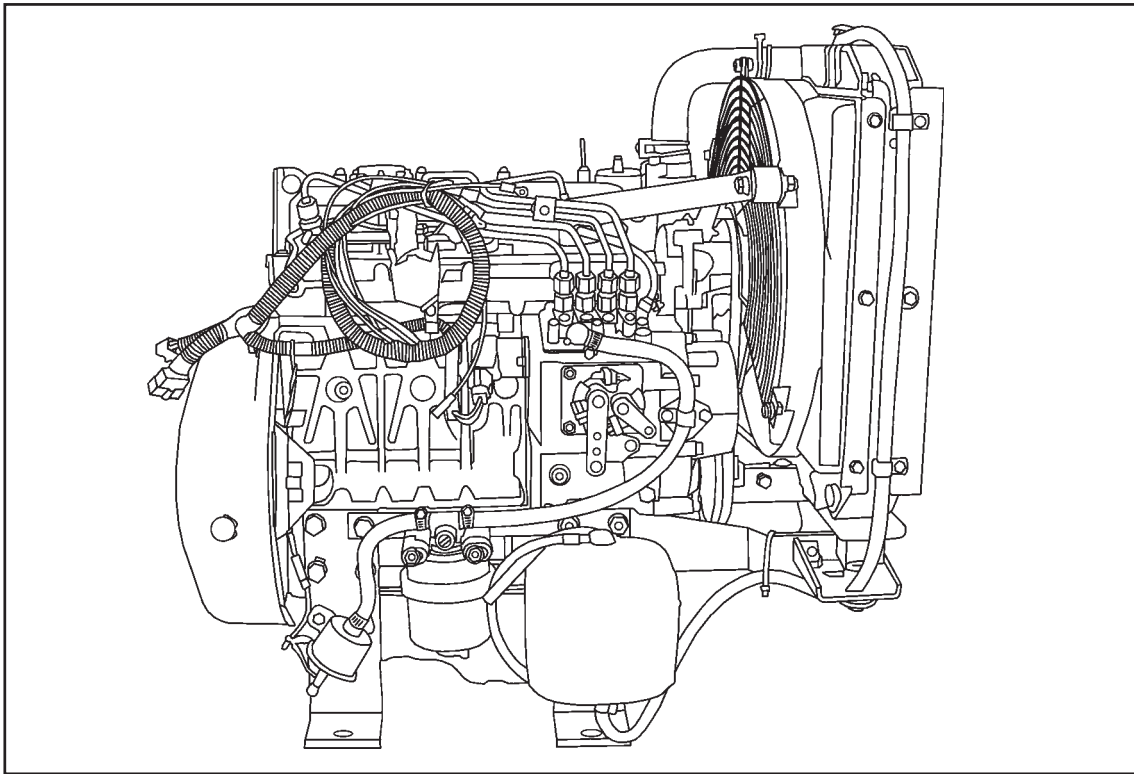

Kubota Engine Right Side

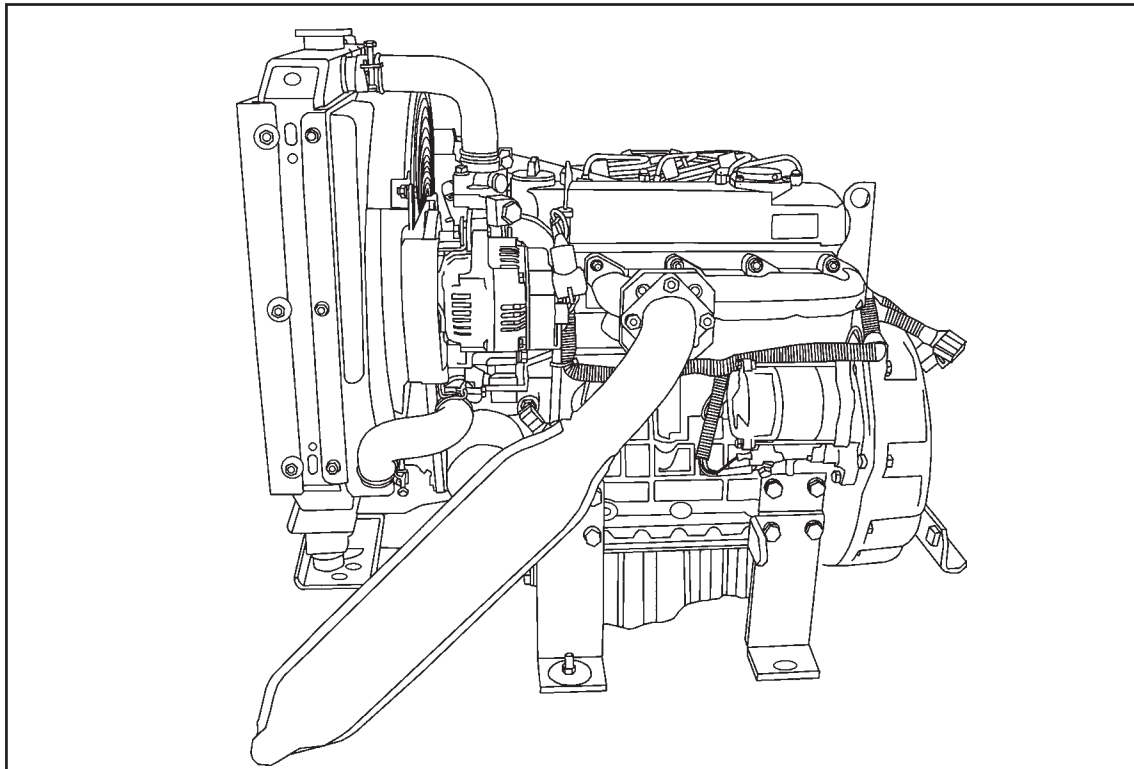

Hydraulic Oil Change and Type Specifications

When your machine is new, the hydraulic system oil and filter should be changed within the first 50 hours of use and every 250 thereafter. Refill the hydraulic reservoir with engine oil type API SF.CD 10W when outside temperature is above 40 degrees F. Use engine oil type API SF.CD 10 weight when outside temperature is below 40 degrees F. It is important to follow these instructions to alleviate any cold weather engine starting problems and any pressure or heat related component failure.

**DO NOT USE HYDRAULIC OIL!
MAJOR DAMAGE WILL RESULT!**

For your engine oil requirements and change intervals refer to your engine owners manual.

WHETHER YOU OWN
ONE TERRAMITE OR 100,
CONTACT OUR
PARTS/SERVICE DEPARTMENT
FOR ANY ADVICE
YOU MAY NEED TO
TAILOR A STOCK LIST
TO YOUR SPECIFIC NEEDS

600 Goff Mountain Road ♦ P.O. Box 7146, Charleston, WV 25356-7146
1-800-428-3772 ♦ Fax 1-800-776-4845
International 1-304-776-4231 ♦ Fax 1-304-776-4845
www.terramite.com

Hydraulic Schematic #1, Main Propel Drive Version 1

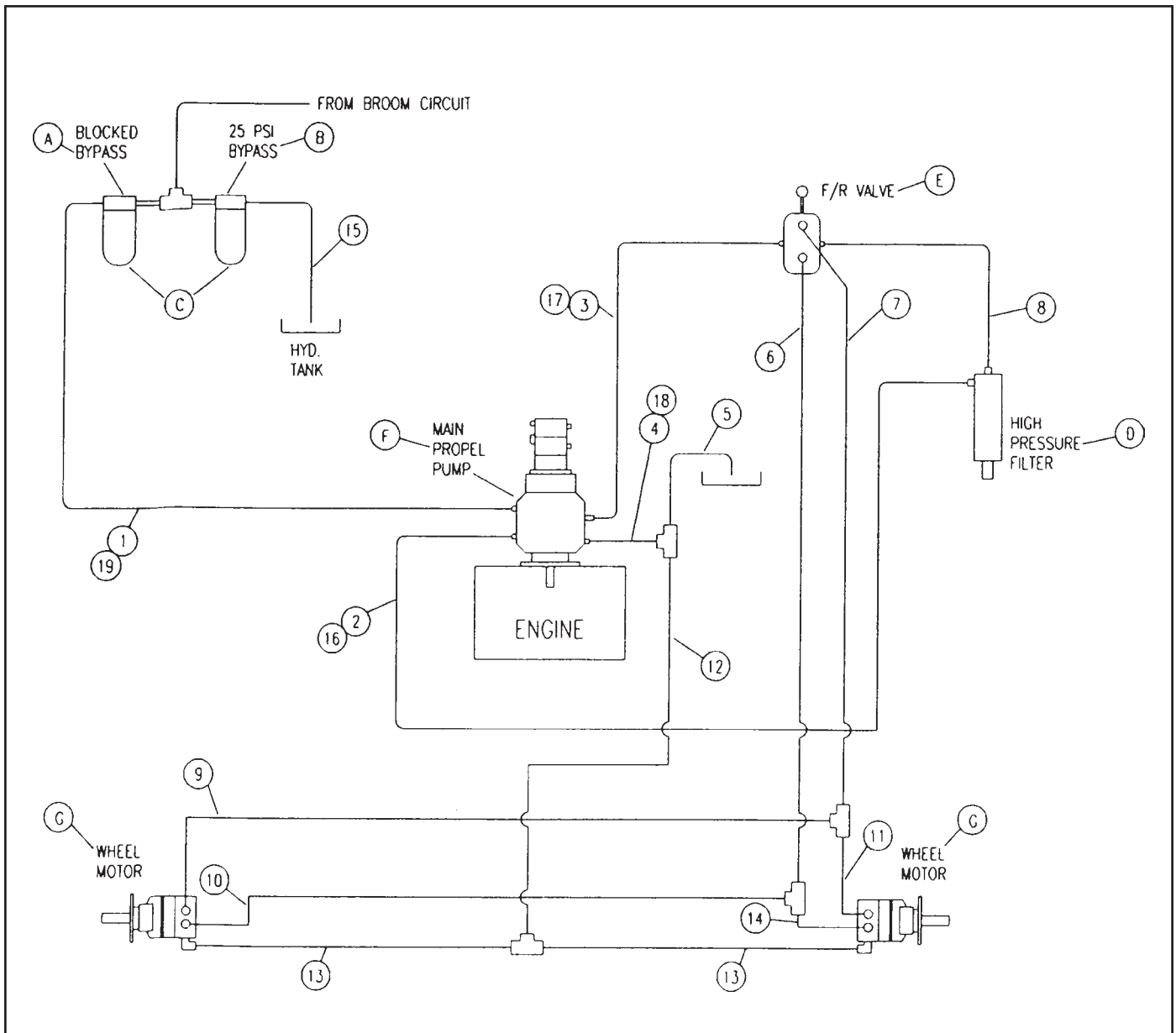

ITEM	PART NUMBER
A	38075
B	38074
C	38076
D	38019
E	38086
F	38058
G	38057
1	38088
2	38089 - Deutz

ITEM	PART NUMBER
3	38090
4	38091 - Duetz
5	38092
6	38090
7	38094
8	38095
9	38096
10	38097
11	38098

ITEM	PART NUMBER
12	38099
13	38100
14	38101
15	38102
16	38215 - Kubota
17	38429 - Kubota
18	38430 - Kubota
19	38431 - Kubota

Hydraulics

Hydraulic Schematic #2, Steering / Auxiliary Version 1

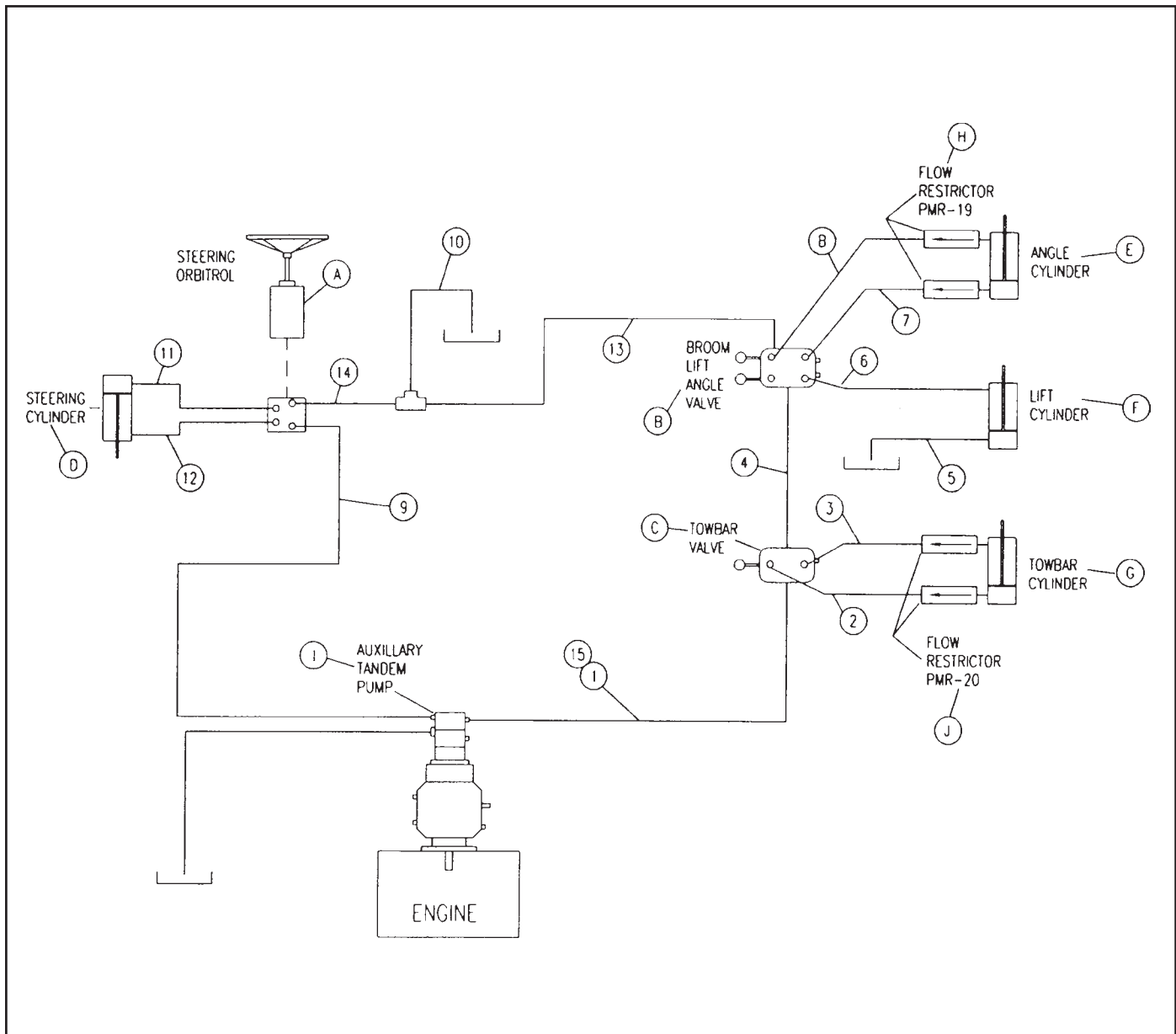

ITEM	PART NUMBER
A	38051
B	38087
C	38026
D	38015
E	38017
F	38016
G	38018
H	38020
I	38081

ITEM	PART NUMBER
J	38105
1	38108 - Kubota
2	38106
3	38107
4	38108
5	38109
6	38110
7	38111
8	38112

ITEM	PART NUMBER
9	38473
10	38091
11	38115
12	38116
13	38117
14	38091
15	38119 - Deutz

Hydraulic Schematic #3, Broom Drive Version 1

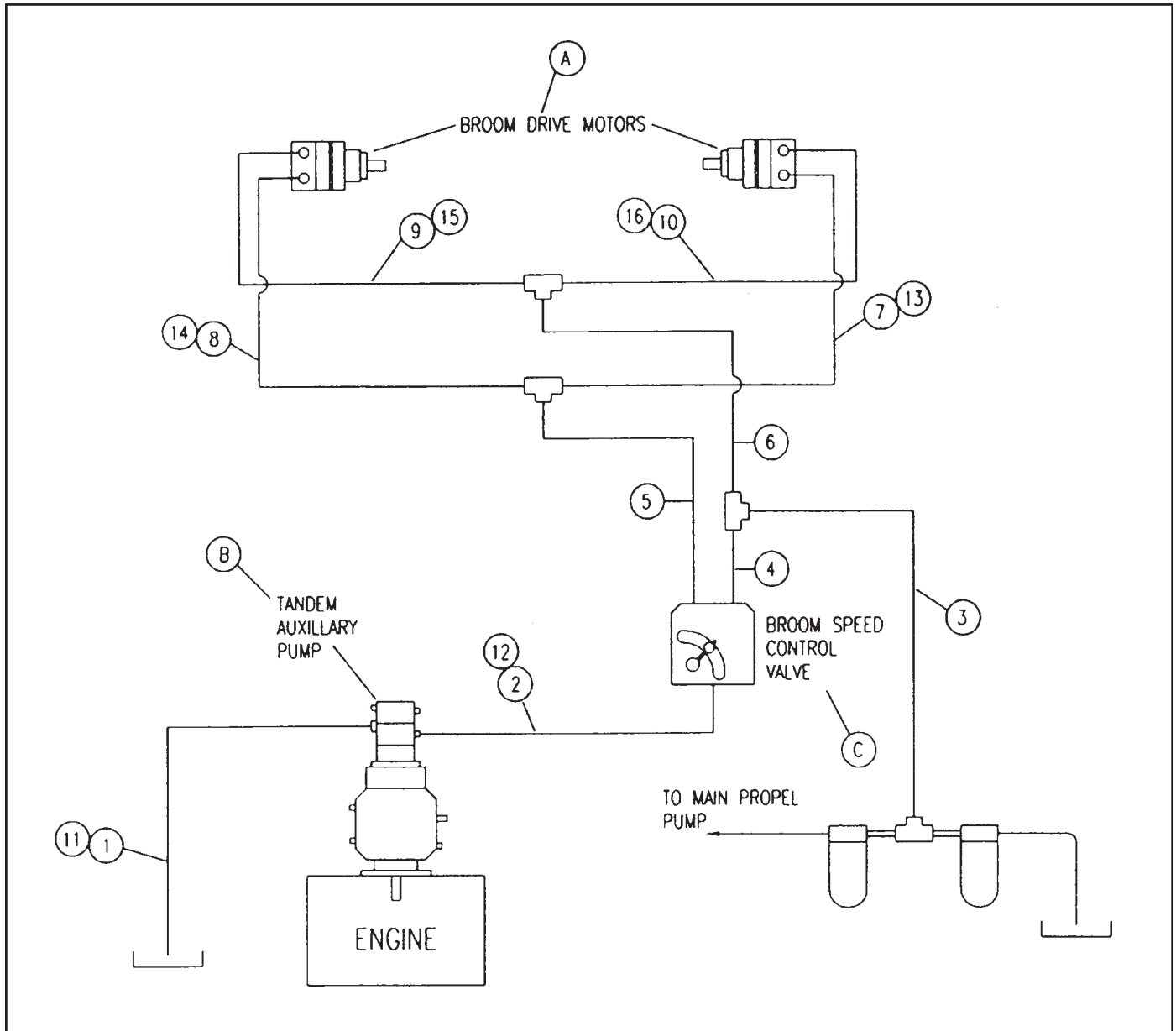

ITEM	PART NUMBER
A	38052
B	38081
C	38082
1	38121 - Kubota
2	38125 - Kubota
3	38125
4	38126
5	38127
6	38128

ITEM	PART NUMBER
7	38129 (8')
8	38131 (8')
9	38133 (8')
10	38135 (8')
11	38122 - Deutz
12	38124 - Deutz
13	38130 (6')
14	38132 (6')
15	38134 (6')

ITEM	PART NUMBER
16	38136 (6')

Hydraulics

Hydraulic Schematic #1, Main Propel Drive Version 2

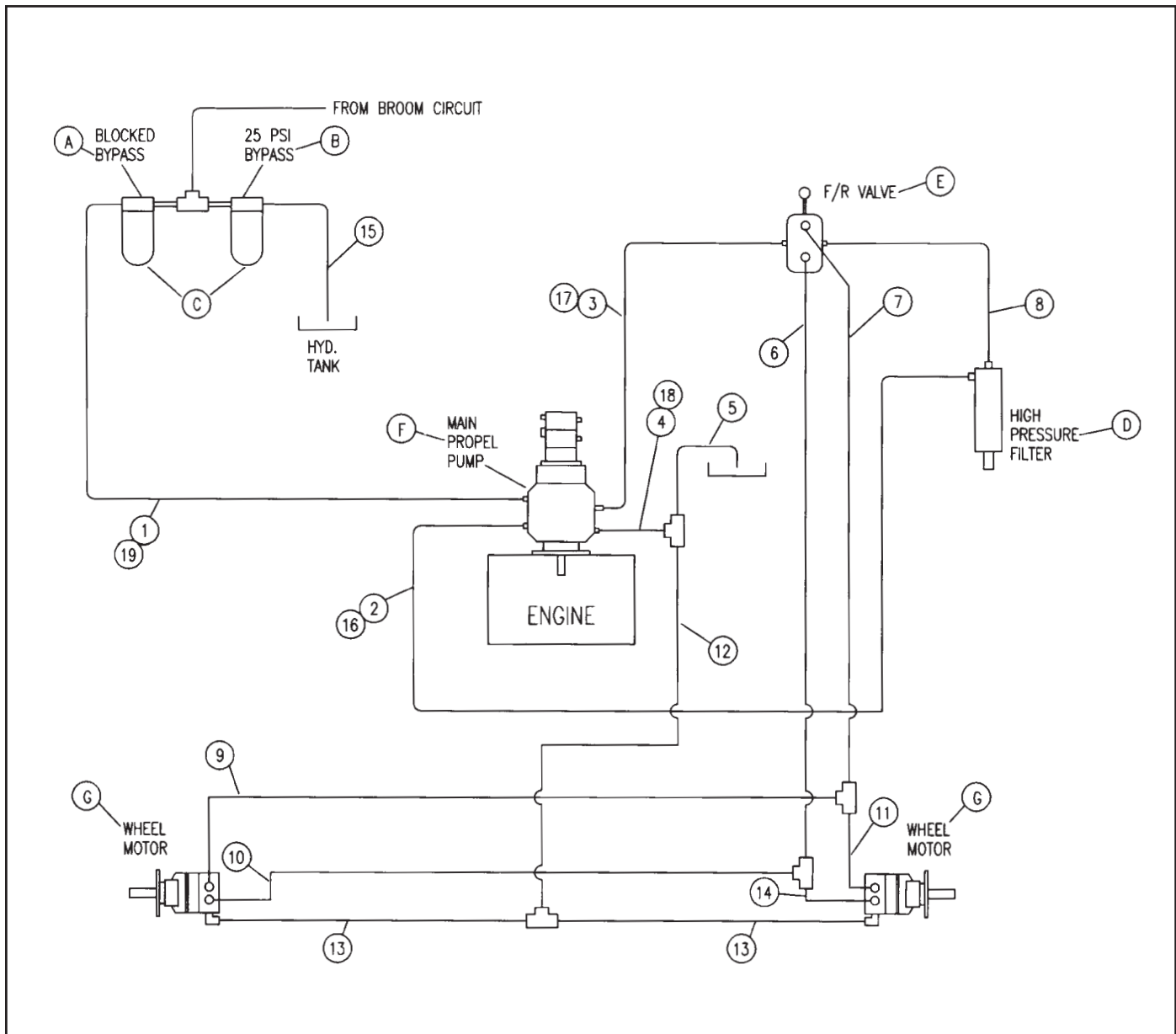

ITEM	PART NUMBER
A	38075
B	38074
C	38076
D	38019
E	38086
F	38058
G	38057
1	38088
2	38089 - Deutz

ITEM	PART NUMBER
3	38090
4	38091 - Deutz
5	38092
6	38090
7	38094
8	38095
9	38096
10	38097
11	38098

ITEM	PART NUMBER
12	38099
13	38100
14	38101
15	38102
16	38215 - Kubota
17	38429 - Kubota
18	38430 - Kubota
19	38431 - Kubota

Hydraulic Schematic #2, Steering / Auxiliary Version 2

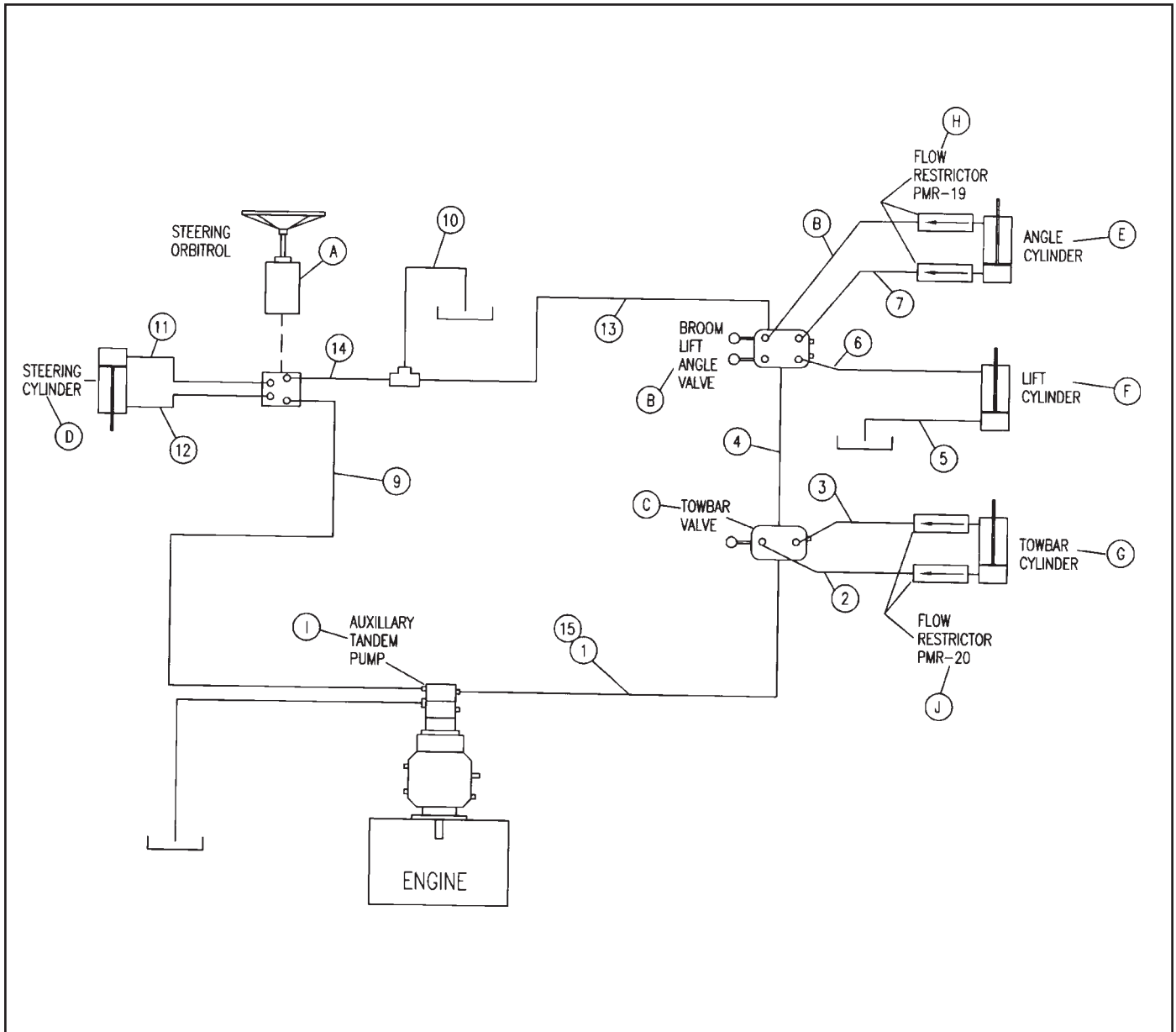

ITEM	PART NUMBER
A	38051
B	38087
C	38026
D	38015
E	38017
F	38016
G	38018
H	38020
I	38081

ITEM	PART NUMBER
J	38105
1	38108 - Kubota
2	38106
3	38107
4	38108
5	38109
6	38110
7	38111
8	38112

ITEM	PART NUMBER
9	38473
10	38091
11	38115
12	38116
13	38117
14	38091
15	38119 - Deutz

Hydraulics

Hydraulic Schematic #3, Broom Drive Version 2

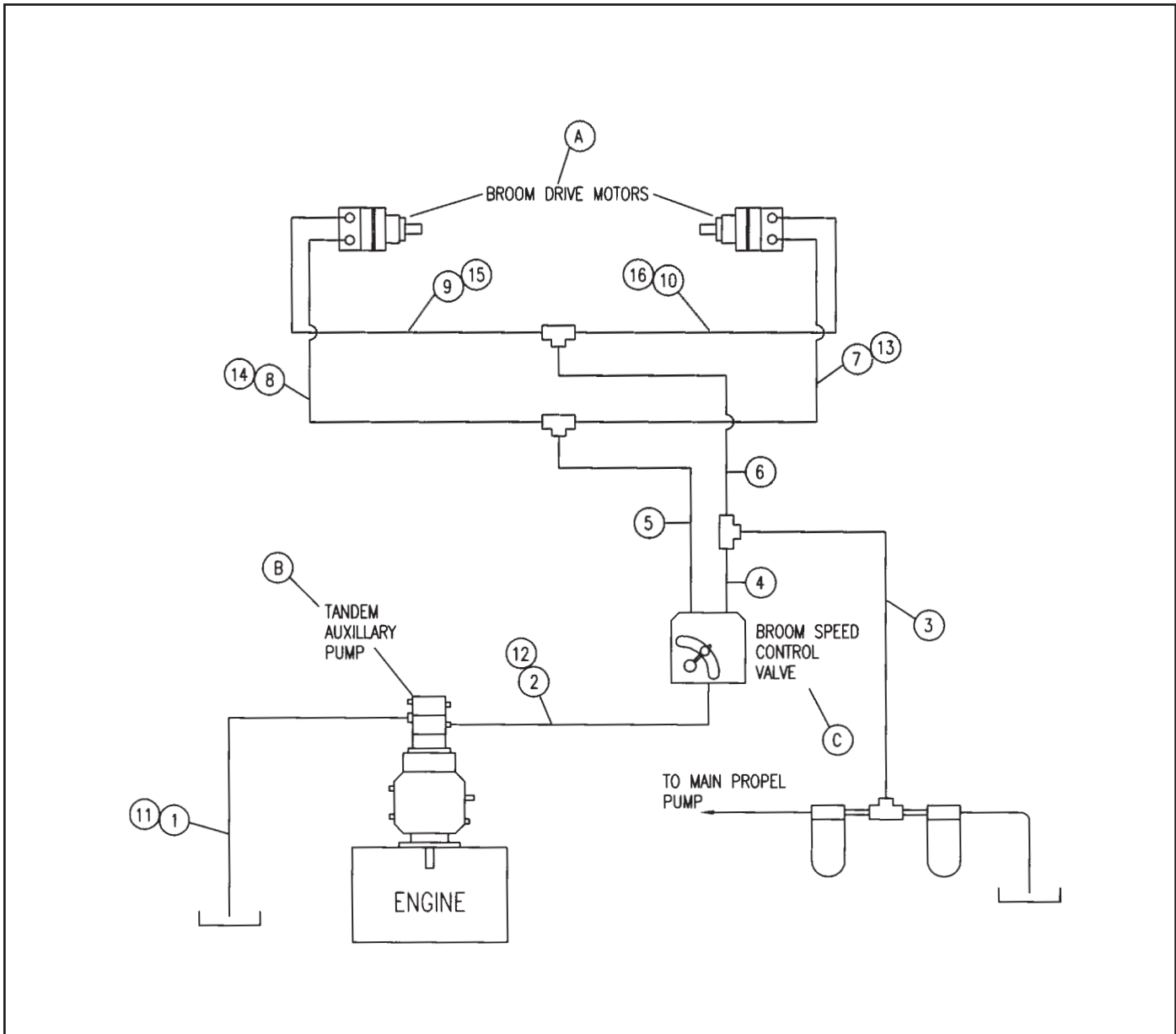

ITEM	PART NUMBER
A	38052
B	38081
C	38082
1	38121 - Kubota
2	38123 - Kubota
3	38125
4	38126
5	38127
6	38128

ITEM	PART NUMBER
7	38129 (8')
8	38131 (8')
9	38133 (8')
10	38135 (8')
11	38122 - Deutz
12	38124 - Deutz
13	38130 (6')
14	38132 (6')
15	38134 (6')

ITEM	PART NUMBER
16	38136 (6')

Hydraulic Schematic #1, Main Propel Drive Version 3

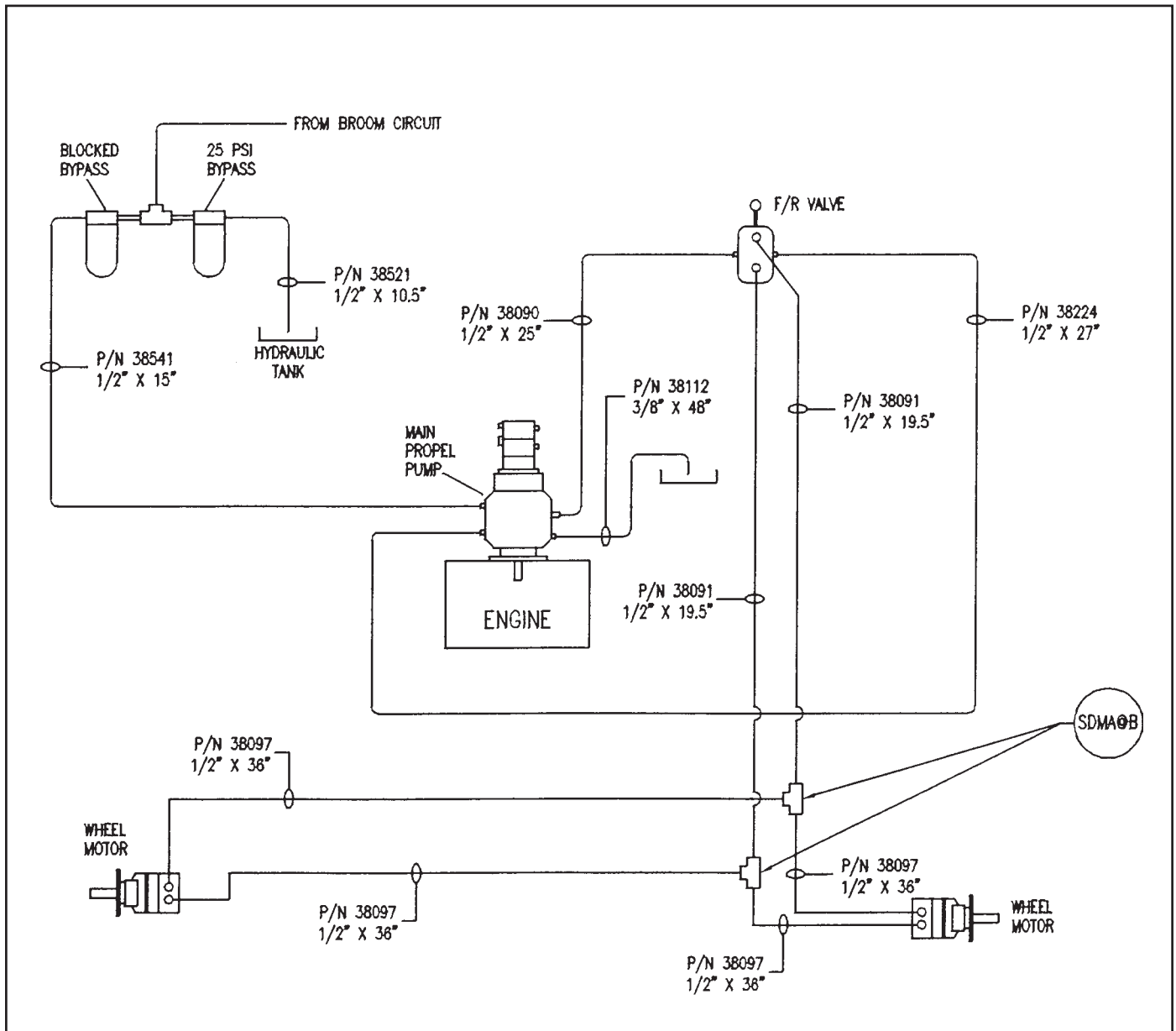

Hydraulics

Hydraulic Schematic #2, Steering / Auxiliary Version 3

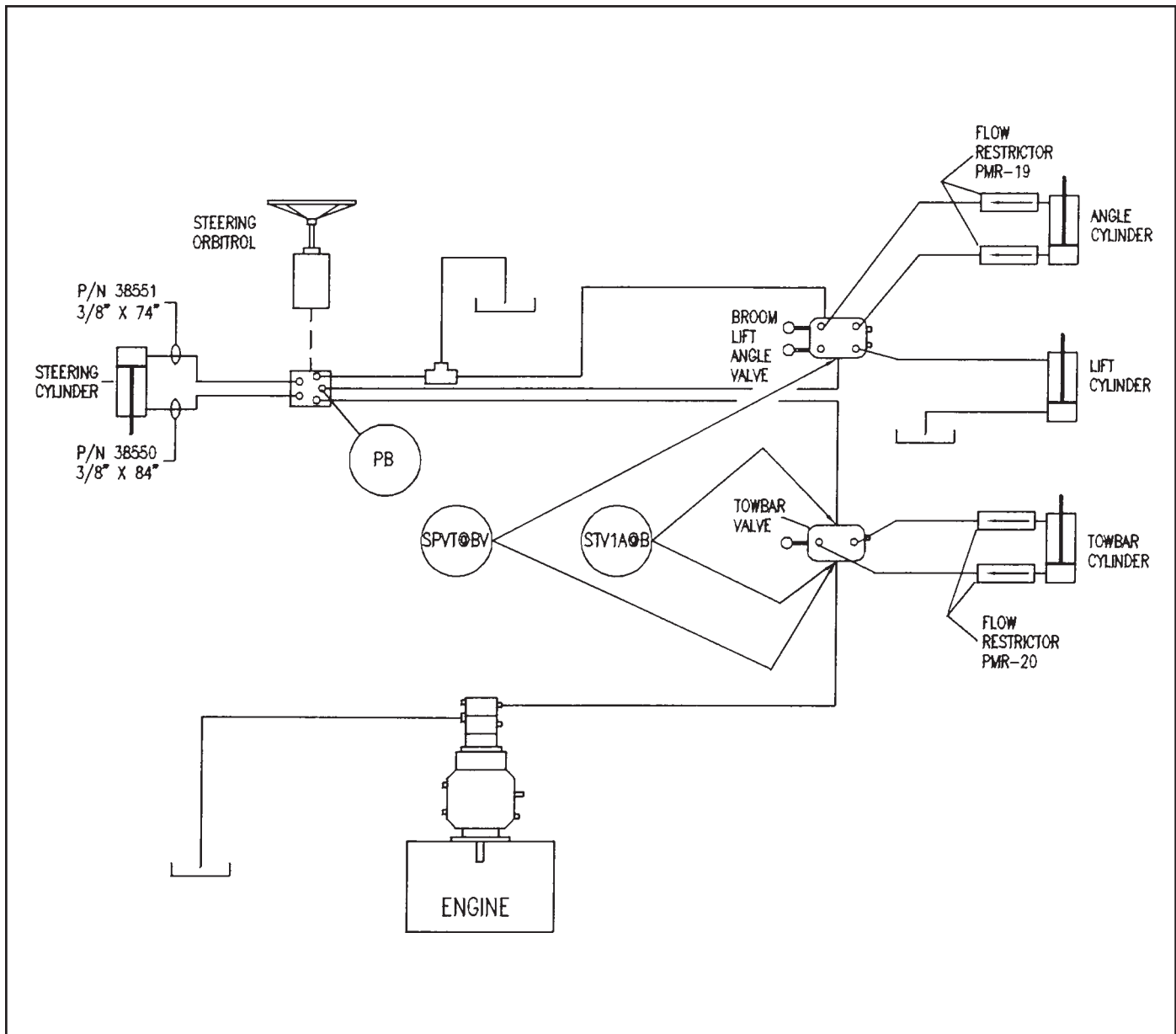

ITEM	PART NUMBER
A	38051
B	38087
C	38026
D	38015
E	38017
F	38016
G	38018
H	38020
I	38081

ITEM	PART NUMBER
J	38105
1	38108 - Kubota
2	38106
3	38107
4	38108
5	38109
6	38110
7	38111
8	38112

ITEM	PART NUMBER
9	38473
10	38091
11	38115
12	38116
13	38117
14	38091
15	38119 - Deutz

Hydraulic Schematic #3, Broom Drive Version 3

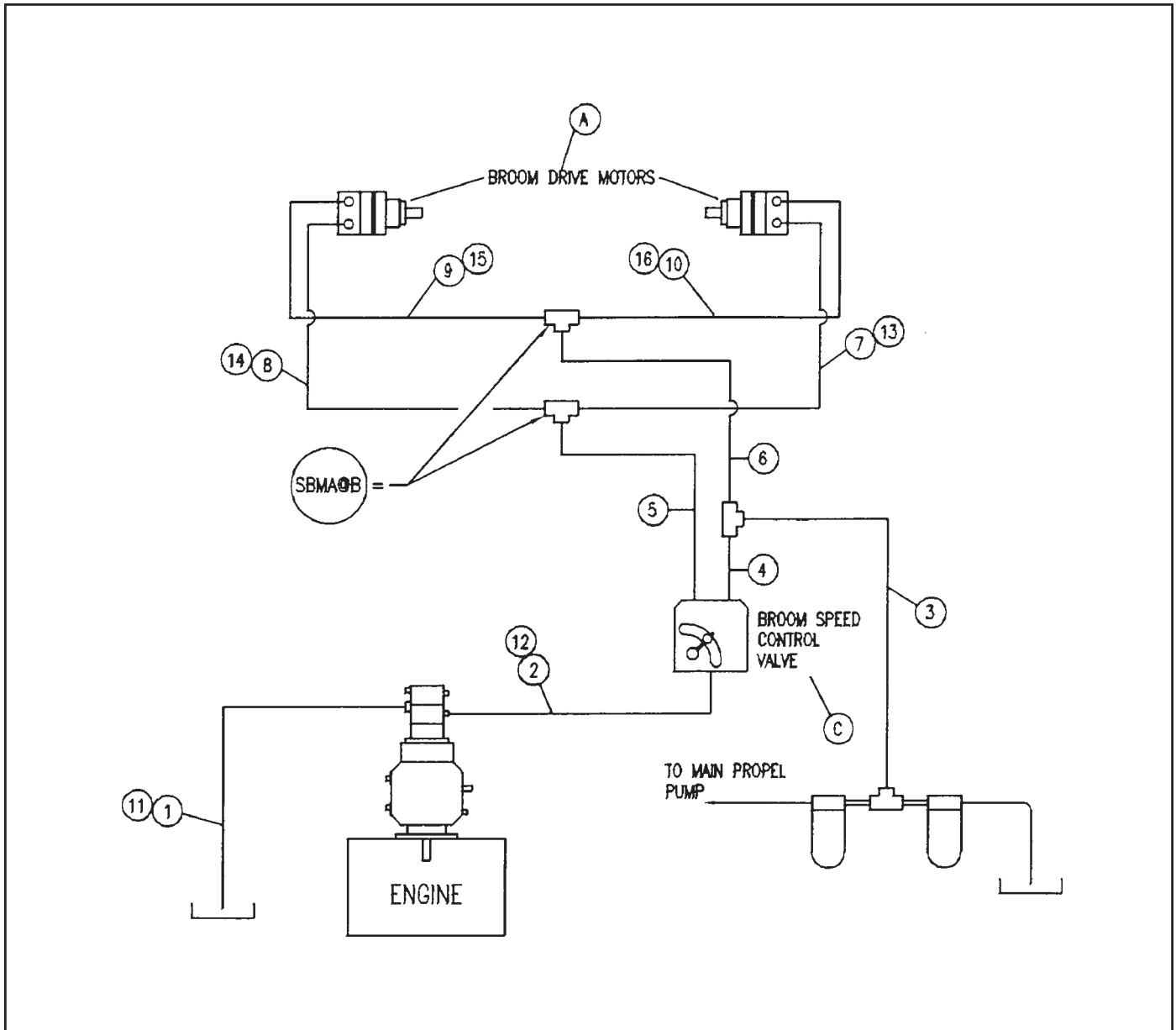

ITEM	PART NUMBER
A	38052
B	38081
C	38082
1	38121 - Kubota
2	38123 - Kubota
3	38125
4	38126
5	38127
6	38128

ITEM	PART NUMBER
7	38129 (8')
8	38131 (8')
9	38133 (8')
10	38135 (8')
11	38122 - Deutz
12	38124 - Deutz
13	38130 (6')
14	38132 (6')
15	38134 (6')

ITEM	PART NUMBER
16	38136 (6')

Wiring Diagram for DIODE Engine

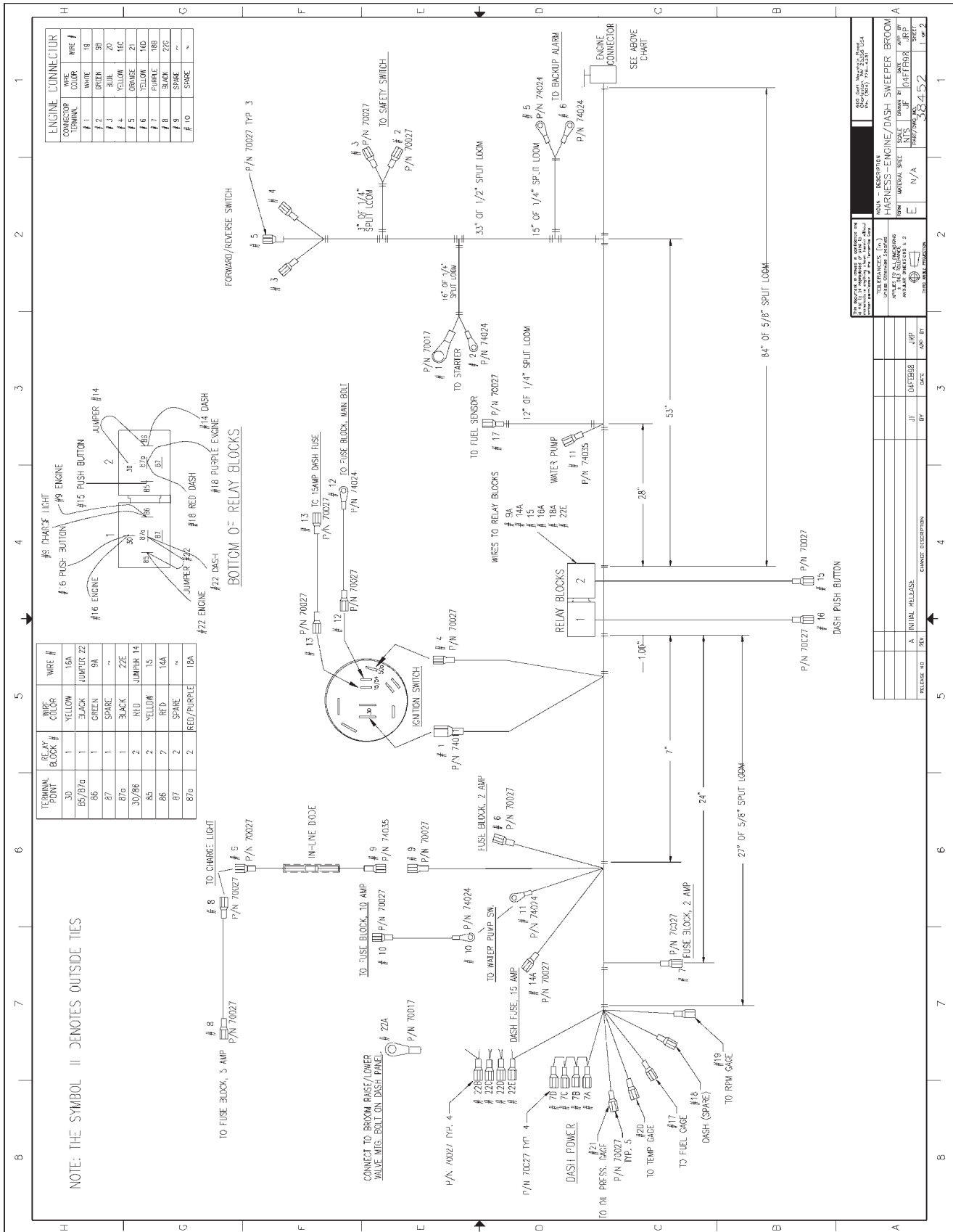

Wiring Diagram Cat Engine

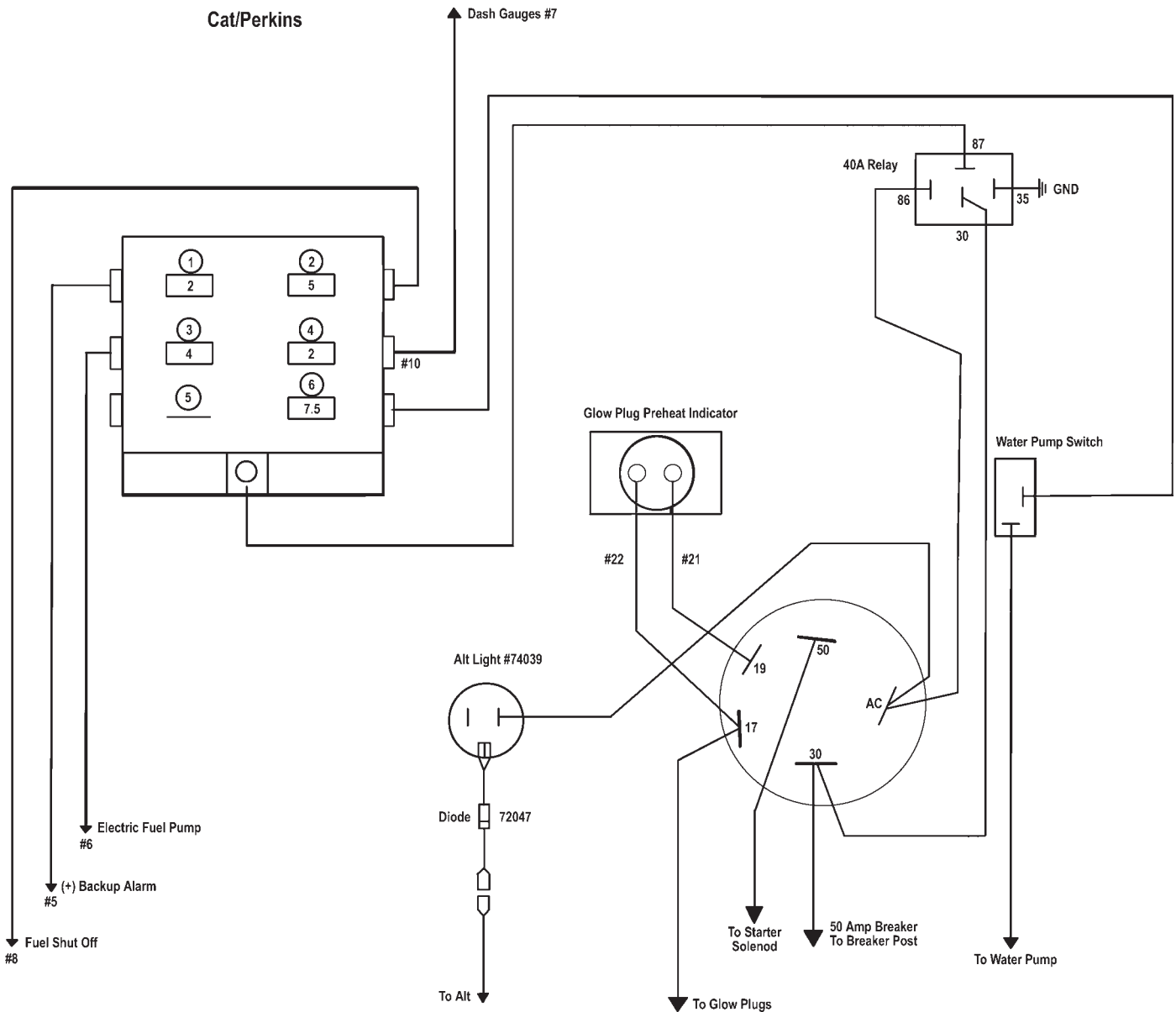

Wiring Diagram Cat Engine

Cat/Perkins Sweeper Wiring

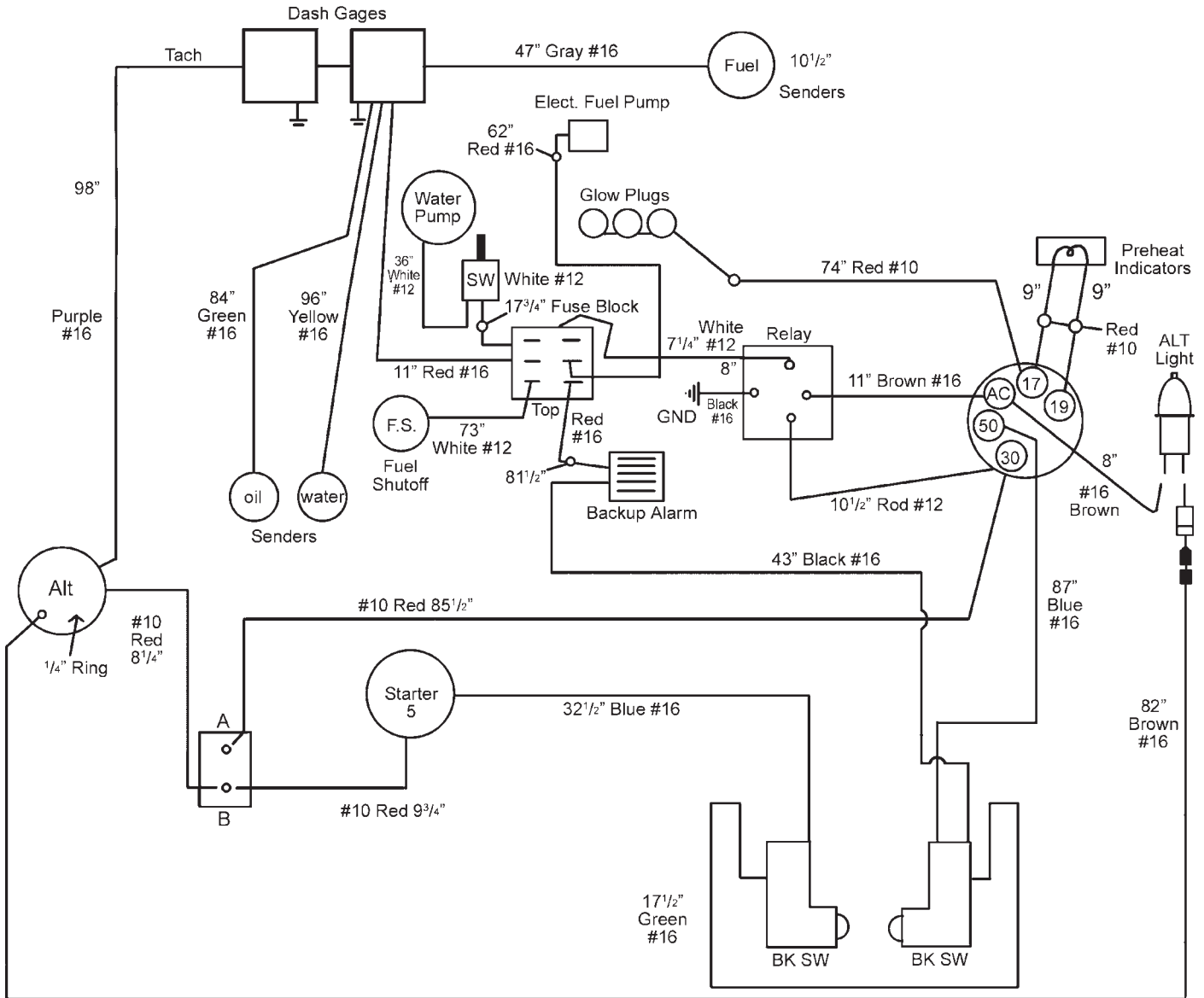

Wiring Diagram Cat Engine

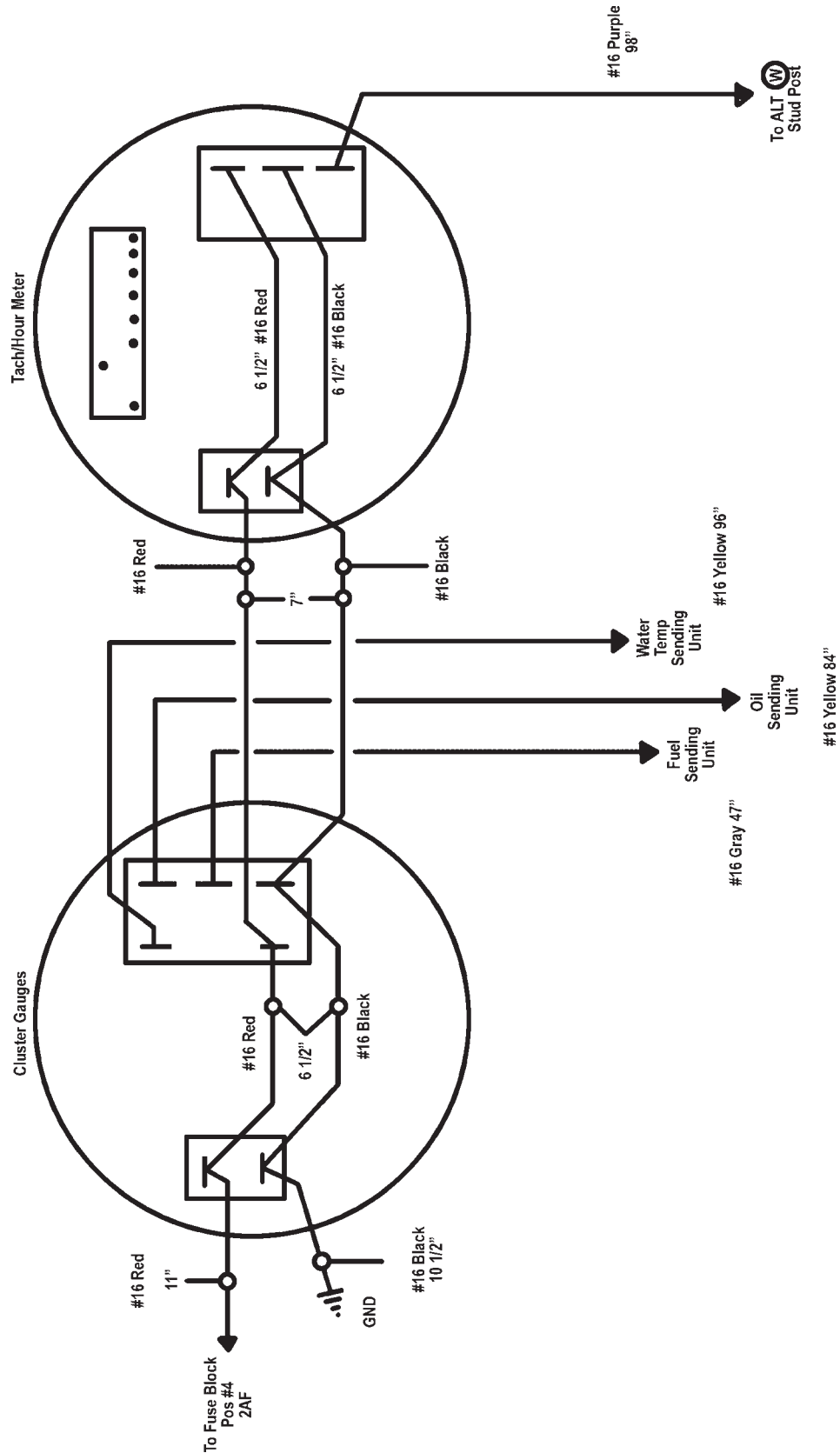

Wiring Harness Diagram for the Kubota Engine

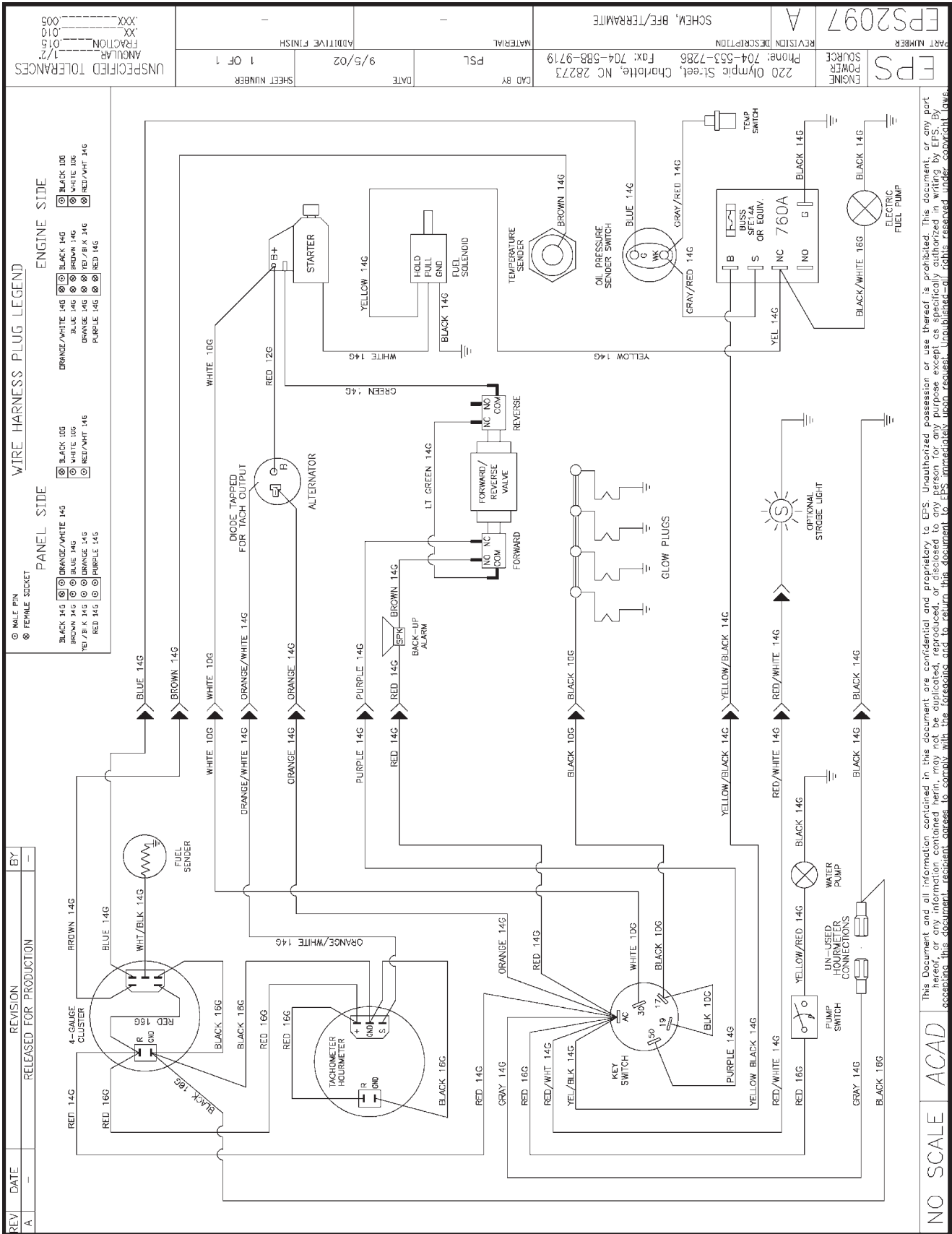

Wiring Schematic Elec. Gauge Panel

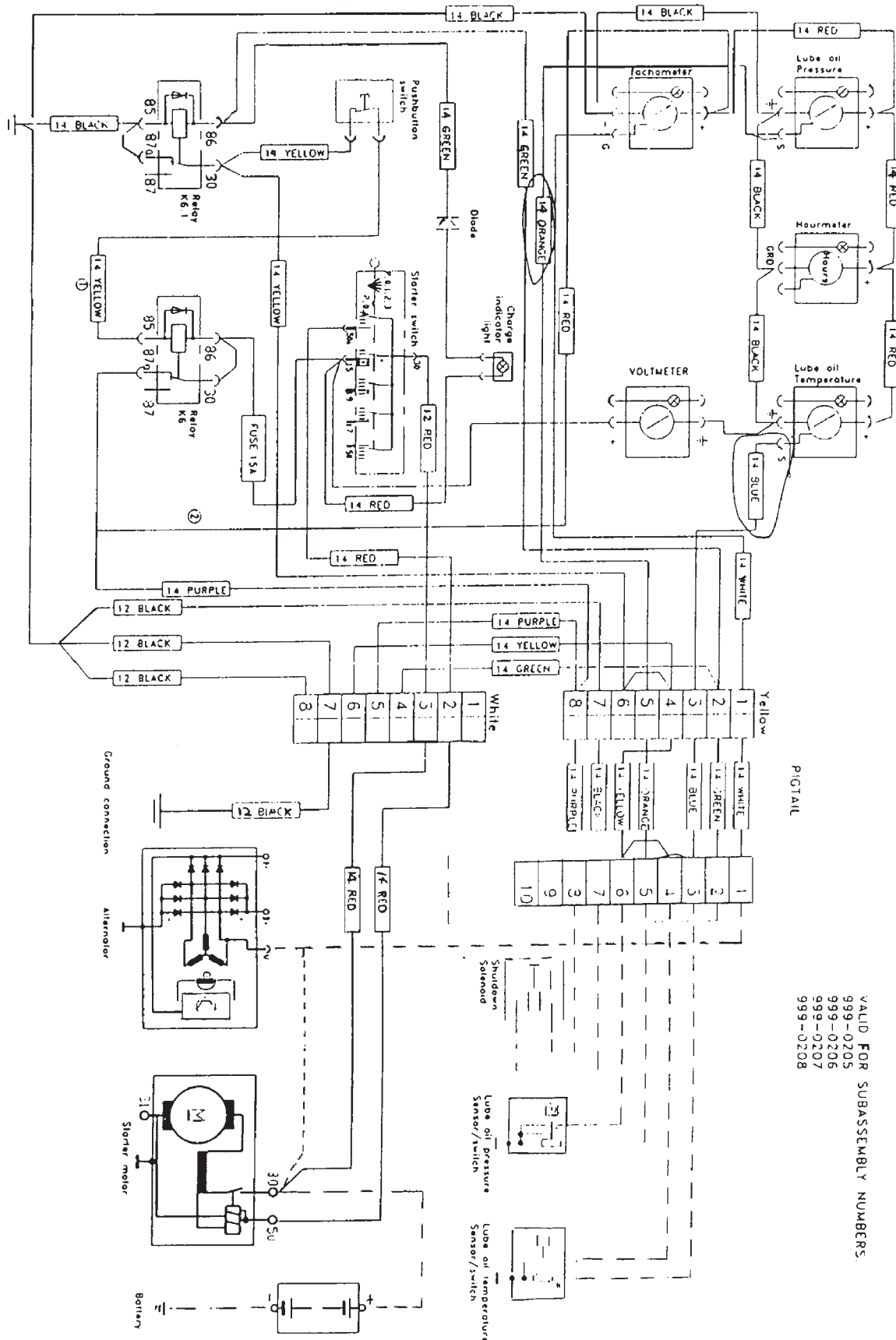

VALID FOR SUBASSEMBLY NUMBERS:
999-0205
999-0206
999-0207
999-0208

Decal Location - Right Side from Operators Position

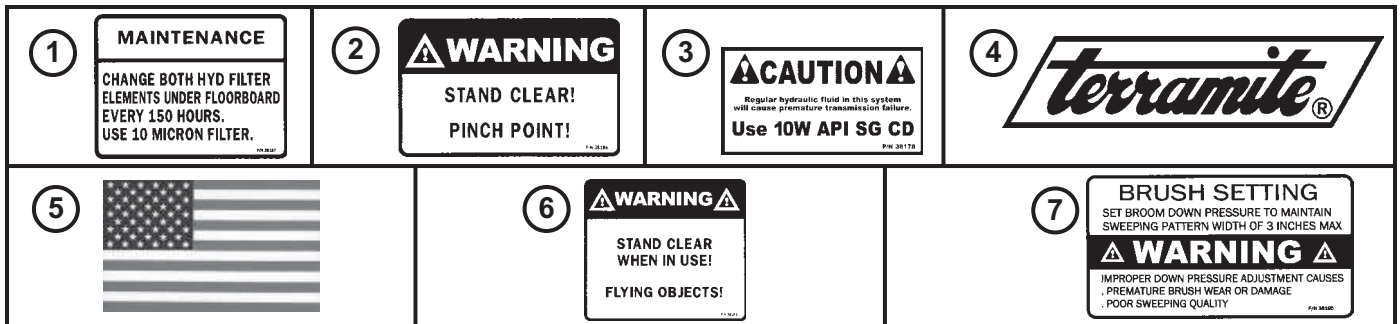
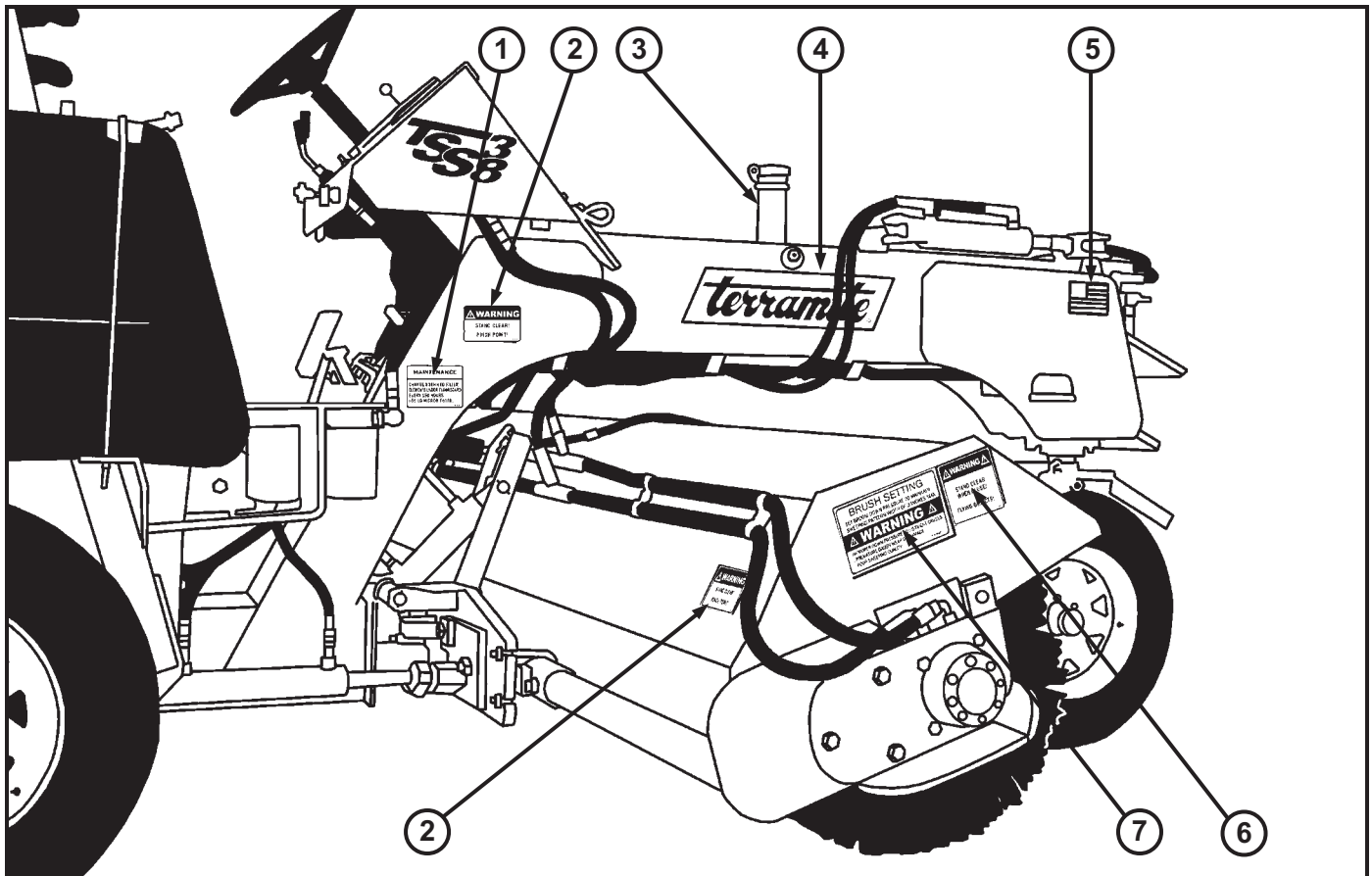



ITEM	PART NUMBER	DESCRIPTION	QTY.
1	38187	Decal, Maintenance, Sweeper	1
2	38186	Decal, WARNING, Stand Clear Pinch Point, Sweeper	6
3	38178	Decal, Use 10W API SG CD, Sweeper	1
4	14001	Decal, Terramite, Sweeper	2
5	14099	Decal, American Flag, Sweeper	2
6	38193	Decal, WARNING, Stand Clear, Flying Objects, Sweeper	4
7	38195	Decal, WARNING, Brush Setting, Sweeper	2

Decals

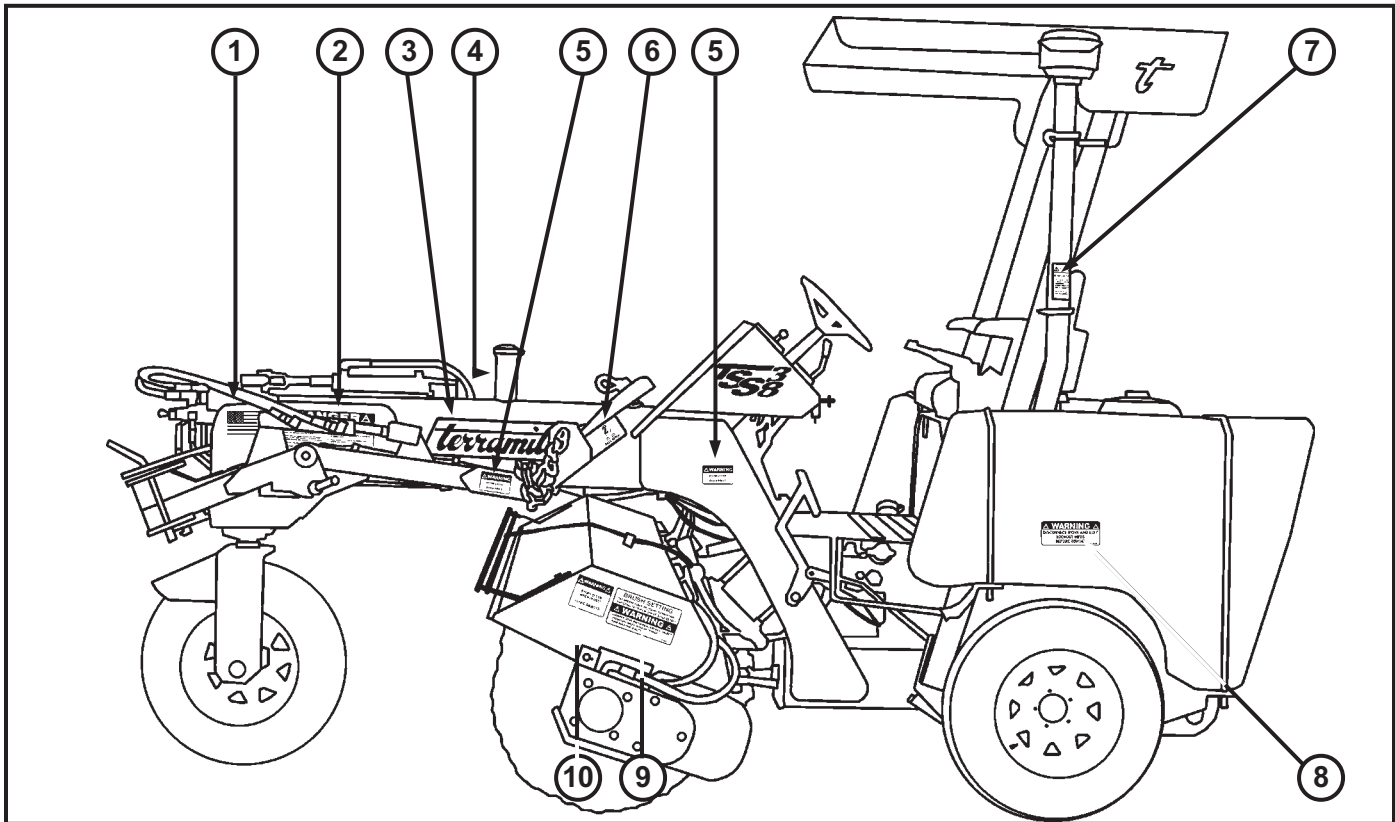
Decal Location - Left Side from Operators Position



<p>1</p> 	<p>2</p> <p>TOWING INSTRUCTIONS</p> <ol style="list-style-type: none"> 1. Set parking brake & turn off engine. 2. Pin tongue in towing position & connect hitch to towing vehicle. 3. Attach safety chain & hook up light cord. 4. Disconnect right & left lockout hubs. 5. Release parking brake before towing. <p>PN 38194</p>	<p>3</p> 	<p>4</p> <p>CAUTION</p> <p>Regular hydraulic fluid in this system will cause premature transmission failure.</p> <p>Use 10W API SG CD</p> <p>PN 38178</p>	<p>5</p> <p>WARNING</p> <p>STAND CLEAR!</p> <p>PINCH POINT!</p> <p>PN 38186</p>
<p>6</p>  <p>BALL HITCH</p>	<p>7</p> <p>CAUTION</p> <p>DO NOT USE ETHER</p> <p>ANY USE OF ETHER OR STARTING FLUID WILL PERMANENTLY DAMAGE ENGINE AND VOID ALL WARRANTY.</p> <p>USE GLOW PLUGS ONLY AS STARTING AID.</p> <p>PN 38185</p>	<p>8</p> <p>WARNING</p> <p>DISCONNECT RIGHT AND LEFT LOCKOUT HUBS BEFORE TOWING</p> <p>PN 38499</p>	<p>9</p> <p>BRUSH SETTING</p> <p>SET BRUSH DOWN PRESSURE TO MAINTAIN SWEEPING PATTERN WIDTH OF 3 INCHES MAX</p> <p>WARNING</p> <p>IMPROPER DOWN PRESSURE ADJUSTMENT CAUSES</p> <ul style="list-style-type: none"> • PREMATURE BRUSH WEAR OR DAMAGE • POOR SWEEPING QUALITY <p>PN 38195</p>	<p>10</p> <p>WARNING</p> <p>STAND CLEAR WHEN IN USE!</p> <p>FLYING OBJECTS!</p> <p>PN 38193</p>

ITEM	PART NUMBER	DESCRIPTION	QTY.
1	14099	Decal, American Flag, Sweeper	2
2	38194	Decal, Towbar Connection Instructions, Sweeper	1
3	14001	Decal, Terramite, Sweeper	2
4	38178	Decal, Use 10W API SG CD, Sweeper	1
5	38186	Decal, WARNING, Stand Clear, Pinch Point, Sweeper	6
6	38482	Decal, 2" Ball Hitch, Sweeper	1
7	38185	Decal, CAUTION, Do Not Use Ether, Sweeper	1
8	38499	Decal, WARNING, Disconnect Right and Left Lockout Hubs, Sweeper	4
9	38195	Decal, WARNING, Brush Setting, Sweeper	2
10	38193	Decal, WARNING, Stand Clear, Flying Objects, Sweeper	4

Decal Location - Right Side from Operators Position

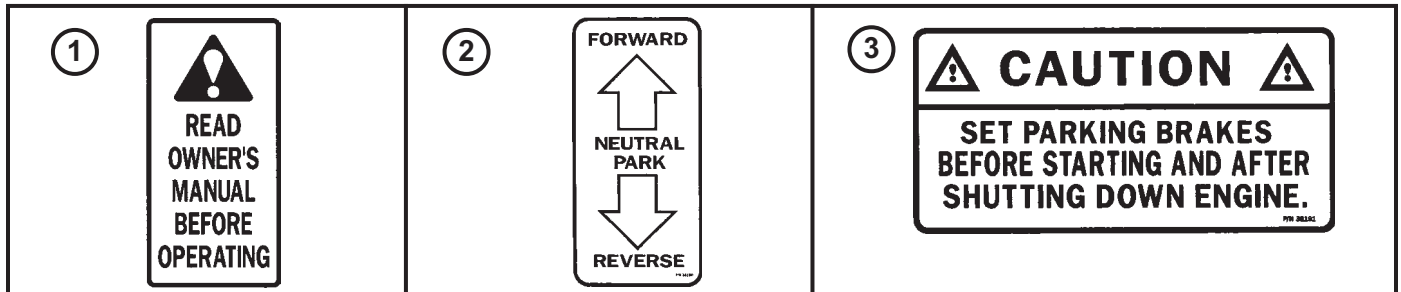
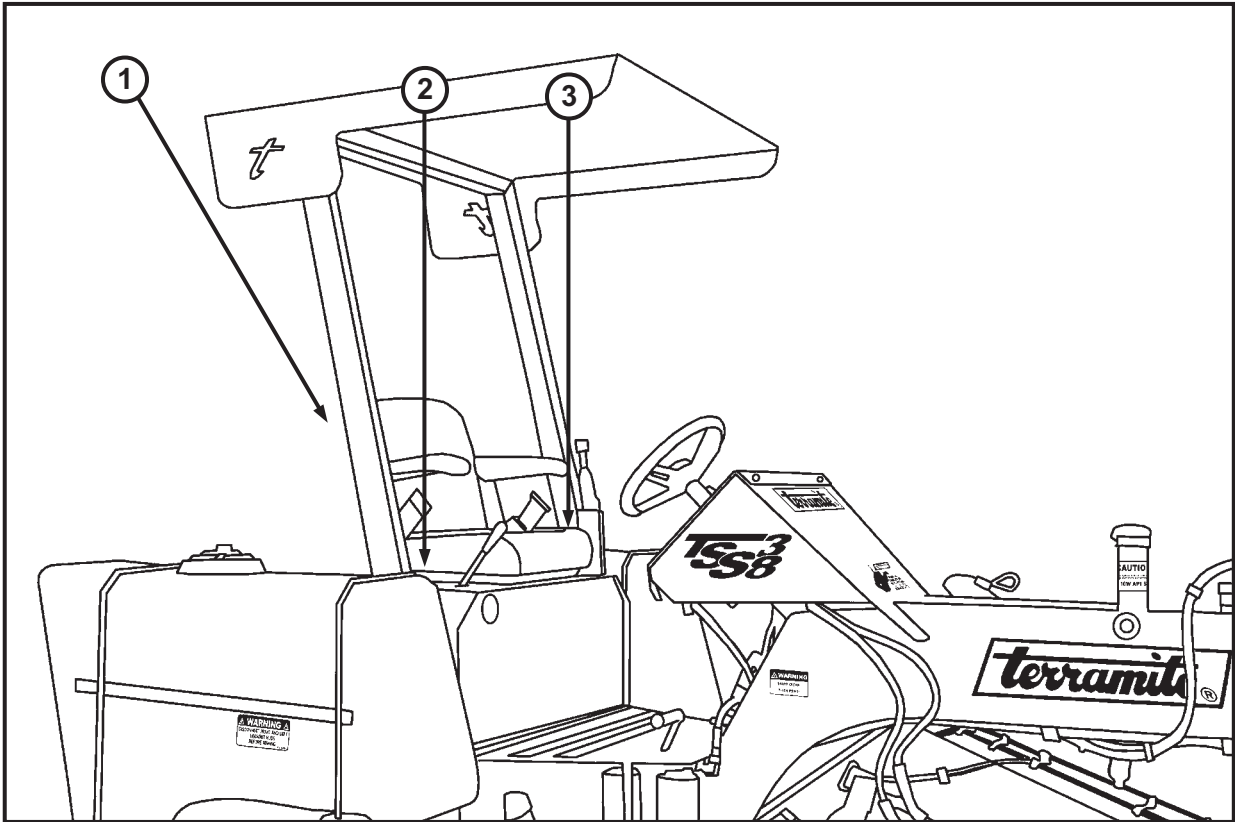

ITEM	PART NUMBER	DESCRIPTION	QTY.
1	14207	Decal, Read Owner's Manual Before Operating, Sweeper	1
2	38180	Decal, Forward/Neutral/Park/Reverse, Sweeper	1
3	38191	Decal, CAUTION, Set Parking Brakes....., Sweeper	1

Decals

Decal Location - Tow Bar

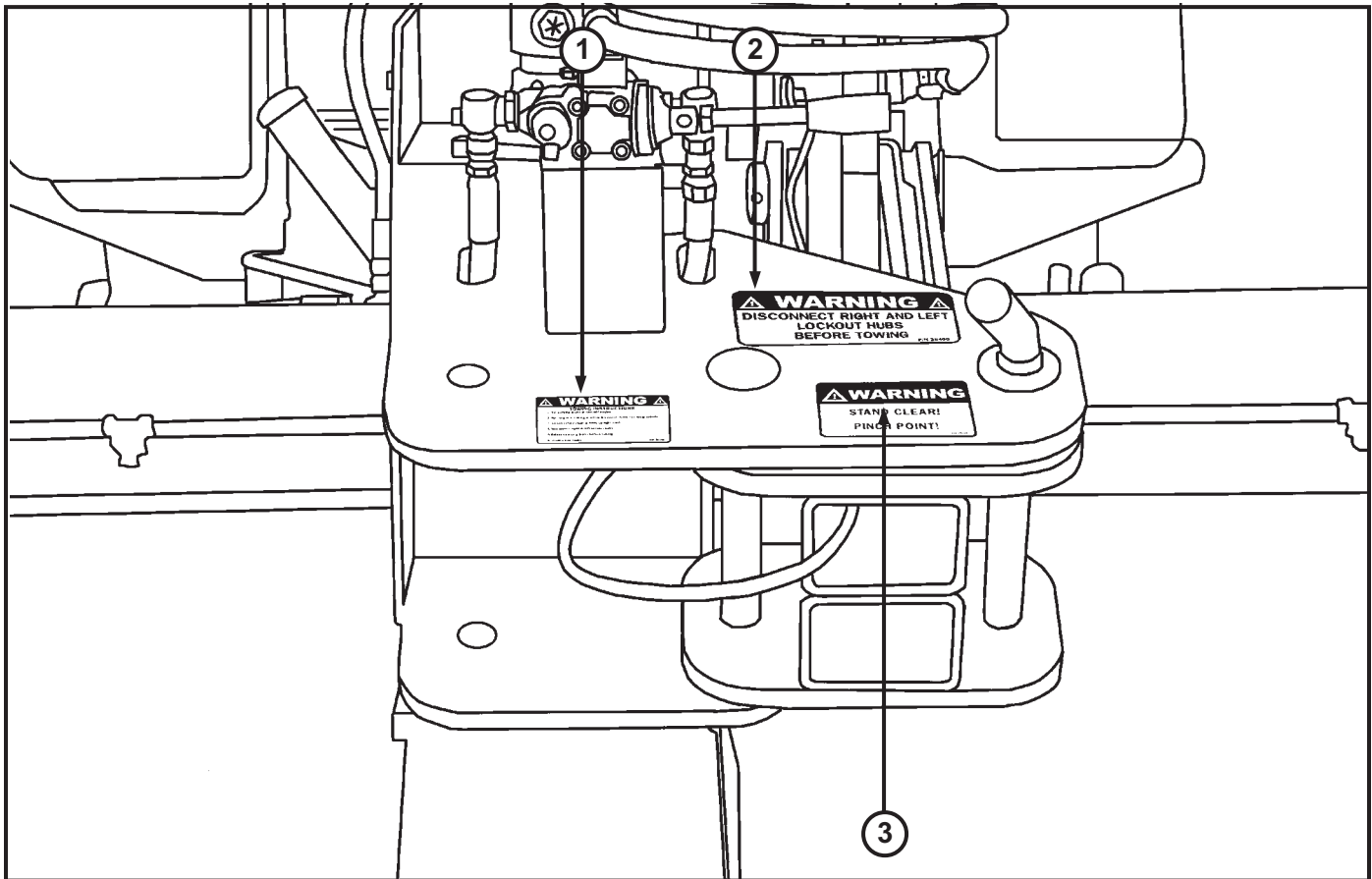

ITEM	PART NUMBER	DESCRIPTION	QTY.
1	38194	Decal, WARNING, Towing Instructions, Sweeper	1
2	38499	Decal, WARNING, Disconnect Right and Left Lockout Hubs, Sweeper	4
3	38186	Decal, WARNING, Stand Clear Pinch Point, Sweeper	6

Decal Location - Dash

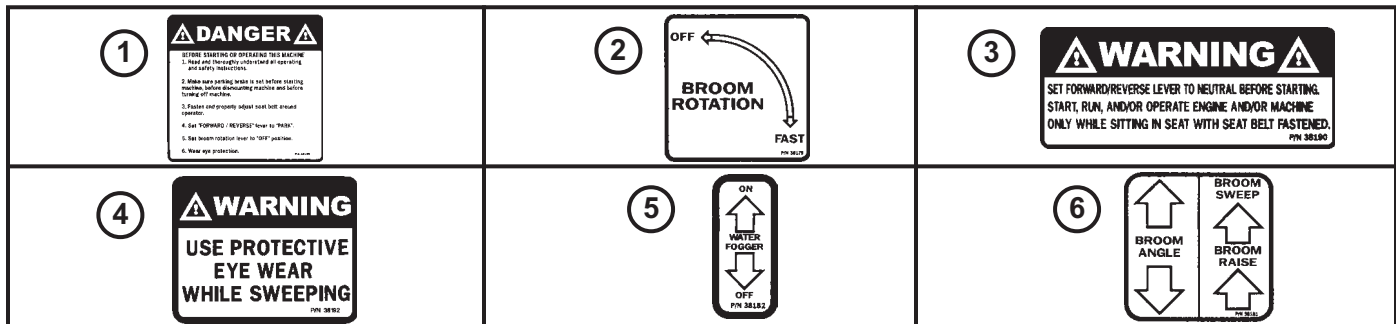
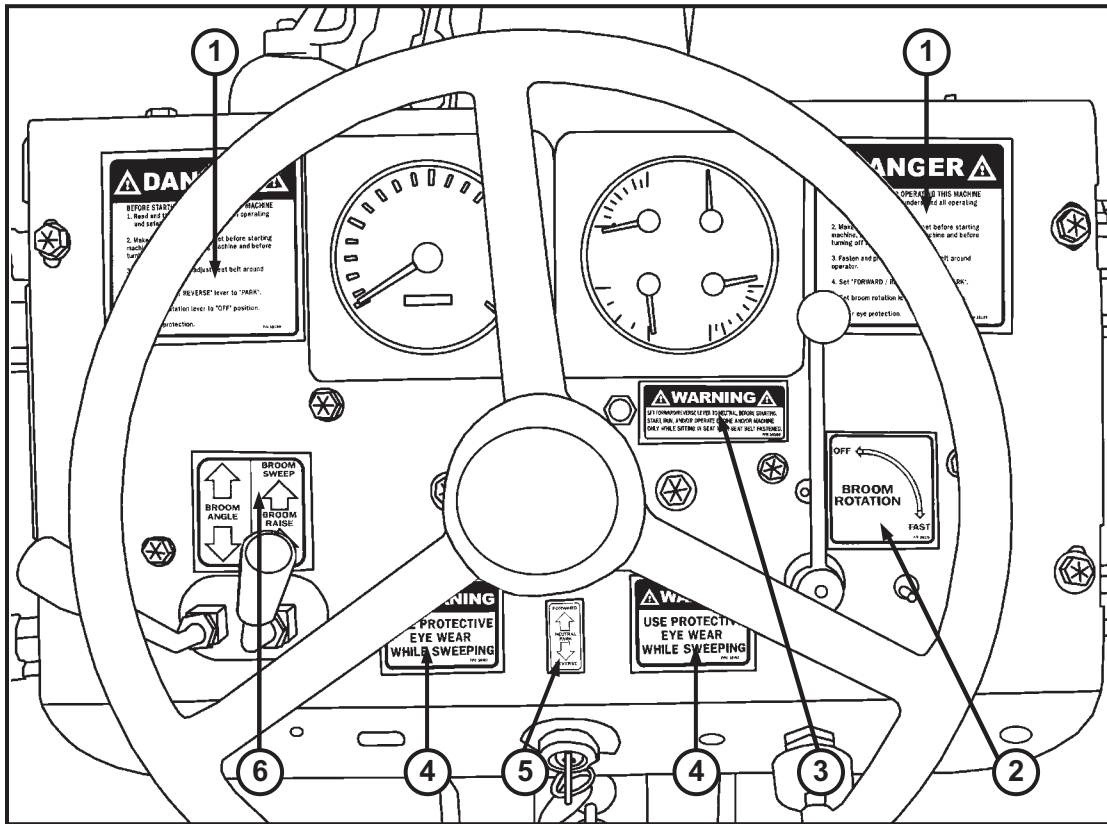

ITEM	PART NUMBER	DESCRIPTION	QTY.
1	38189	Decal, DANGER, Before Starting This Machine...., Sweeper	2
2	38179	Decal, Broom Rotation, Sweeper	1
3	38190	Decal, WARNING, Set Forward/Reverse Lever..., Sweeper	1
4	38192	Decal, WARNING, Use Protective Eye Wear, Sweeper	2
5	38182	Decal, On/Water/Fogger/Off, Sweeper	1
6	38181	Decal, Broom Angle, Sweeper	1

Translation Chart

ENGLISH	FRANÇAIS	DEUTSCH	ESPAÑOL
adapter	adaptateur	Zwischenstück	adaptador
arm	bras	Arm	brazo
axle assembly	essieu ensemble	Achse vollst	eje conjunto
axle shaft	arbre d'essieu	Achsenwelle	barra eje
bearing	palier	Lager	cojinete
body	carrosserie	Karosserie	carrocería
body assembly	ens carrosserie	Karosserie vollst	conj carrocería
bolt	boulon	Bolzen	bulón
boom	flèche	Hubarm	aguilón
boot	capuchon	Kappe	capuchón
bracket	support	Winkel	grampa
brake head assembly	étrier frein ens	Bremskopf vollst	cabeza freno conj
brake lever assembly	ens levier trein	Bremsebel vollst	conj planca freno
brake shoe	patin frein	Bremsschuh	zapata freno
breather	reniflard	Entlüse	carcasa
bucket	godet	Schaufel	cucharón
bushing	chemise	Buchse	buje
button	bouton	Knopf	botón
cable	câble	Kabel, Seil	Cable
cam	came	Nocke	leva
cap	chapeau	Kappe	tapa
carburetor	carbureteur (mélangeur)	Vergaser	carburador
case	carter	Gehäuse	caja
chain	chaînes	Kette	cadena
Channel	canal, moulure	U-Träger, Profil	perfil
choke	enrichisseur	Starterklappe	ahogador
circuit breaker	disjoncteur	Unterbrecher	disyuntor
circuit	circuit	Stromkreis	circuito
clamp	attche, collier	Klammer, Einspannbacke	abrazadera
cleaner	épurateur	Luftreiniger	filtro
clevis	chape	Gabelkopf	horquilla
clip	agrafa	Klemme, Bügel	fbroche
collar	collier	Bundring, Flansch	collar
column	montant, colonne	Säule	columna de dirección
cone	cône, bague intérieure	Konus, Kegel	cónico
connecting	de liaison	verbinden	conectar
connection	connexion	Verbindungsstück,	conexión
connector	raccord	Anschluss, Stecker	conector
control	commande	Steuerung, Betätigung	control
converter	convertisseur	Drehmomentwandler	convertidor
cotter pin	goupille fendu	Splint	chaveta
counterweight	contrepoids	Gegengewicht	contrapeso
coupler	raccord	Anschlusstück, Schnellwechsler	conector, enganche
coupling	accouplement	Verbindungsstück	acoplamiento
cover	couvercle	Deckel	cubierta, tapa
crankcase	carter moteur	Kurbelgehäuse	cárter
crankshaft	vilebrequin	Kurbelwelle	cigüeñal
crosshead	traverse	Kreuzkoph	cruceta
cup	coupelle	Aussenring, Schale	taza

Translations

Translation Chart (Continued)

ENGLISH	FRANÇAIS	DEUTSCH	ESPAÑOL
cushion	coussin	Dämpfungselement, Sitzpolster, Vollgummi	amortiguador
cylinder	cylindre	Zylinder	cilindro
cylinder block	bloc-cylindres	Motorblock, Zylinderblock	bloque de motor
decals	décalque, décalcomanie	Abziehbild, Beschriftung	calcomania
detachable	amovible	abnehmbar, geteilt	separable
differential	différentiel	Differential	diferencial
diode	diode	Diode	diodo
dipstick	jauge baïonnette	Messstab	varilla medidora
direction switch	inverseur de marche	Richtungsschalter	interruptor de direccion
directional	de sens de marche	richtungsabhängig	sentido de marcha
disc	disque	Scheibe	disco
distributor	allumeur	Verteiler, Zündverteiler	distribuidor
divider	diviseur, répartiteur	Teller, Verteiler	divisor
dowel	goujon	Passstift, Haltestift	espiga
drive axle	essieu moteur	Antriebsachse	eje motriz
drum	tambour	Trommel	tambor
dual	jamelé, double	doppelt, zweifach	doble
elbow	coude	Kniestück, Winkelstück	codo
element	élément	Element, Einsatz	elemento
enclosure	carter, carénage	Umrandung, Gehäuse	compartimiento
end	terminal, extrémité	Ende	extremo
engine	moteur	Motor	motor
exhaust	échappement	Auspuff	escape
extension	prolongement, rollonge	Verlängerung	extensión
exhaust valve	souparpe d'échappement	Auspuff-, Auslassventil	válvula de escape
fan	ventilateur	Lüfter	ventilador
felt	feutre	Filz	anillo de retén
fender	aile, pare-boue	Schutzblech, Kofflülge	guardabarros
film	film, autocollant	Aufkleber	película
filter	filtre	Filter	filtro
fitting	graisseur, raccord	Nippel, Schraubverbindung	acoplamiento
flap	rabat, bavette	Felgenrand, Klappe	pestaña
flasher	clignotant	Blinkgeber	contacto intermitente
flash lamp	ampoule de clignotant	Blinkleuchte	bombilla intermitente
float	flotteur	gleiten, schwimmen	flotador
floor	sol, plancher	Boden	piso
flow	débit, courant, flux	Strömung, Durchfluss	flujo
flywheel	volant (moteur)	Schwungradscheibe	volante
flow protector	protecteur de débit	Durchfluss-Schutzvorrichtung	protector de flujo
foot	pied	Fuss	pie
fork	fourche	Gabel	horquilla
forward	en avant	vorwärts	adelante, hacia adelante
frame	châssis	Rahmen	bastidor
front	avant	vorne, Front	frente, parte delantera
fuel	carburant	Kraftstoff	combustible
FFTL	triple levée	Dreifach-Vollfreihub	alto despejo libre
fuse	fusible	Sicherung	fusible
gasket	joint	Dichtung	junta

Translation Chart (Continued)

ENGLISH	FRANÇAIS	DEUTSCH	ESPAÑOL
guage	jauge	Anzeiger	medidor, indicador, calibrador
gear	pignon, engrenage	Zahnrad, Gang	engranaje
glow plug	bougie de préchauffage	Glühkerze	bujía incandescente
grommet	virole	Tülle, Dichtungsring	arandela aislante
group	ensemble	Gruppe, Satz	grupo
guard	protecteur	Schutz, Abdeckung	protector
guide	guide	Führung	guía
hand brake	frein à main	Handbremse	freno de emergencia
handle	poignée	Griff, Handgriff	asa
harness	faisceau	Kabelbaum, Verdrahtung	mazo de cables
head	tête	Kopf	culata
head lamp	phare AV	Scheinwerfer	luz delantera
height	hauteur	Höhe	altura
hinge	charnière	Gelenk, Scharnier	bisagra
hold down	tendeur	Aufspannvorrichtung	sujetador
holder	support	Halter	soporte
hood	capot	Motorhaube	capó
hook	crochet	Zughaken	gancho
horn	avertisseur	Hupe, Signalhorn	bocina
hose	durite, flexible	Schlauch	manguera
housing	boîtier, carter	Gehäuse	caja
hub	moyeu	Nabe, Radnabe	maza
hydraulic	hydraulique	Hydraulik	hidráulico
ignition	allumage	Zündung	encendido
indicator	indicateur	Anzeigevorrichtung	indicador
injection	injection	Einspritzung	inyección
injector	injecteur	Einspritzventil	inyector
inner	intérieur	innen	interior
insert	pièce rapportée	Einsatz	inserto
instrument	instrument	Instrument	instrumento
insulation	isolation	Isolierung	aislante
insulator	isolateur	Isolator, Nichtleiter	aislador
intake valve	soupape d'admission	Ansaugventil	válvula de admisión, válvula de aspiración
interface	surface de réparation, interface	Übertragungseinheit	entrecara, zona Interfacial
jacket	chemise, jupe	Mantel, Wärmeisolierung	camisa, chaqueta
intermediate	intermédiaire, moyen	indirekt	intermedio, medianero
joint	joint	Gelenk, Verbindung	junta, unión, juntaura
keeper	détente	Gegenmutter, Halter	tirante, fijader, retentór
key	clé, clavette	Schlüssel, Keil	llave
lever	levier	Hebel	palanca
leveler	niveleur, correcteur	Planierer	nivelador
light	lumière	Leuchte	luz
line	canalisation	Leitung	tuberia
liner	chemise, garniture	Laufbuchse	camisa
lining	revêtement, garniture (frein)	Auskleidung, Belag	revestimiento, forro
link	baillette, maillon	Glied, Gelenkstück	eslabón
locknut	contre-écrou	Kontermutter, Siche-	tuerca de traba

Translations

Translation Chart (Continued)

ENGLISH	FRANÇAIS	DEUTSCH	ESPAÑOL
		rungsmutter	
lockwasher	rondelle d'arrêt	Federring	arandela de seguridad
magnet	aimant	Magnet	imán
manifold	collecteur	Krümmer	múltiple
master cylinder	maître-cylindre	Hauptzylinder	cilindro maestro
maximum	maximum	maximal	máximo
meter	instrument, mètre	Messgerät	medidor, dosificador
modulating	de modulation	Modulation	modulador
motor	moteur	Motor, elektr.	motor
mount	support	anbauen, montieren	montar
mounting	montage	Befestigung, Anbausatz	montaje
muffler	silencieux d'échappement	Schaildämpfer	silenciador
nipple	graisseur	Schmiernippel	boquilla
nut	écrou	Mutter	tuerca
oil	huile	Öl	aceite
oil level	niveau d'huile	Ölstand	nivel del aceite
outer	extérieur	aussen	exterior
oil filter	filtre à huile	Ölfilter	filtro de aceite
O-ring	joint torique	O-Ring	sello anular
oversize	surdimensionné, majoré	Übermass, Übergrösse	sobremedida
packing	garniture d'étanchéité	Abdichtung	empaquetadura
pad	tampon, coussin	Polster, Unterlagsblock	almohadilla
pan	carter, cuvette	Ölwanne	colector del cárter
panel	tableau	Verkleidungsblech, Instrumentenbrett	panel, tablero de instrumentos
pedal	pédale	Pedal	pedal
pin	goupille, axe	Bolzen, Stift	pasador
pinion	pignon	Ritzel	piñón
piston	piston	Kolben	pistón
pivot	pivot	Anlenk-, Drehpunkt, Auf- hängung	pivote
plate	plaque, plateau	Platte, Blech	placa, plancha
plug	bouchon	Schraubstopfen	tapón, bujía
plunger	plongeur	Tauch-, Ventilkolben	émbolo
polished	poli	poliert	pulido
precleaner	préfiltre	Vorreiniger	antefiltro
primary	primaire	Haupt-, Vor-, primär	primario
priority	priorité, séquence	Sicherheits-, Vorrang	prioridad
protector	protecteur	Schutzvorrichtung	protector
pulley	pulie	Riemenscheibe	polea
pump	pompe	Pumpe	bomba
push rod	poussoir	Schubstange	varilla de empuje
race	chemin de roulement, cuvette	Lager-, Laufring	anillo de cojinete
radiator	radiateur	Kühlernetz	radiador
rail	rail (glissière)	Schiene	riel, mástil
rear	arrière, AR	rückwärts, hinten	posterior, trasero
rectifier	redresseur	Gleichrichter	rectificador
regulator	régulateur	Regler, Reguliervorrichtung	regulador
relay	relais	Relais	relé

Translation Chart (Continued)

ENGLISH	FRANÇAIS	DEUTSCH	ESPAÑOL
relief valve	soupape de décharge	Überdruckventil	válvula de alivio
repair	réparation	Reparatur	reparación
required (Reqd.)	requis	erforderlich	requerido
reservoir	réservoir	Tank	depósito, tanque
retainer	arrêtoir	Halterung	retén
reverse	marche AR	Rückwärtsgang	marcha atrás, reverso
right hand (RH)	côté droit, à droit	rechts	lado derecho (L.D.)
ring	anneau, joint	Ring	anillo, aro, argolla
rivet	rivet	Niete	remache
rocker arm	culbuteur	Kipphebel	balancin
rod	bielle	Stange, Pleuelstange	varilla
roller	galet	Laufrolle	rodillo
rotor	rotor	Rotor, Laufrad	rotador, rotor, rodete
seal	joint	Dichtring	sello
seal-o-ring	joint torique	O-Ring-Dichtung	anillo, anillo de estancamiento
sealant	produit d'étanchéité	Dichtungsmittel	sellante, sellador
seal-u-cup	joint en demi-lune	U-Profil-Dichtungsring	copa en "U"
seat	siège	Sitz	asiento
secondary	secondaire	Anbau-, Hilfs-, Sekundär	secundario, auxiliar
sender	émetteur, sonde	Geber (Kraftstoffstand)	sensor
sending unit	émetteur	Messwertgeber	unidad sensora
separator	séparateur	Separator, Abscheider	separador
setscrew	vis de fixation	Gewindestift	tornillo de traba, tornillo prisionero
shaft	arbre, axe	Welle	eje, mango largo, rastágo
shield	bouclier, écran de protection	Abdeckung, Schild	protector
shim	cale de réglage	Beilagscheibe	calce
short block	bloc-moteur nu	Teil-, Skelettmotor	bloque de motor sin accesorio, bloque parcial
shroud	panneau, plaque	Abdeckplatte	cubierta, refuerzo de ventilador
sideshift	déport latéral	Seitenschubvorrichtung	desplazador lateral
sleeve	manchon, chemise	Büchse, Hülse	manguito
snap	jonc d'arrêt	Sprengring	anillo de presión, cierre de resorte
socket	douille, chape	Fassung	enchufe
solenoid	solénoïde	Magnetspule	solenoide
spacer	entretoise	Distanzstück	espaciador
spark plug	bougie d'allumage	Zündkerze	bujía
spider	croisillon	Gelenkkreuz	cruceta
spindle	pivot, fusée, broche	Spindel, Achszapfen	punta de eje
spool	tiroir	Ventilstößel	carrete
springs	ressort	Feder	resortes
sprocket	barbotin	Antriebsrad	rueda dentada
standard (Std.)	normal	Standard	estándar
starter	démarrreur	Anlasser	arranque
stationary (Stat.)	stationnaire	Aussenmast, stationär	estacionario, inmóvil
stator	stator	Ständer, Stator	estator

Translations

Translation Chart (Continued)

ENGLISH	FRANÇAIS	DEUTSCH	ESPAÑOL
steering	directon	Lenkung	directción
stem	tige	Schaft	vóstago
strainer	filtre, crépine	Sieb	filtro
strap	sangle	Riemen, Gurt	banda, correa
strut	étai, tirant	Strebe	tirante de dirección
stud	goujon, tenon	Stehbolzen	espárrago
support	support	Auflager, Abstützung	soporte
switch	interrupteur	Schalter	interruptor
tag	étiquette	Anhänger	etiqueta
tapered	conique	konisch, kegelförmig, verjüngt	perfil cónico, aguzado
tappet	poussoir	Anschlag, Stößel	levantaválvulas
tee	té	T-Stück	conexión "T"
terminal	borne	Anschlussklemme	terminal
thermistor	thermistor	Thermistor, Temperatur- fühler	termistor
thermostat	thermostat	Thermostat	termostato
tightner	tendeur	Spanner	tensor, ajustador
tilt cylinder	vérin d'inclinaison	Neigezylinder	cilindro de inclinación
tire	pneumatique	Reifen	neumático
transfer	déclacomanie, autocollant	Abziehbild	transferencia
transmission	transmission, boîte de vi- tesses	Getriebe	transmisión
tread-step	marchepied	Triffstufe	estribo antirresbalante
tube	tuyau, tube, gicleur	Rohr, Schlauch	tubo
tubing	canalisations	Rohr, Schlauchleitung	tuberias, tubos
undersize	sous-dimensionne, minore	Untermass	bajomedida
union	raccord	Anschlusstück, Verbinaung	unión
universal joint	cardan	Kreuzgelenk	junta universal
upright	montant	senkrecht, Hubgerüst	montante vertical
valve	soupape, clapet	Ventil	válvula
valve mechanism	culbuterie	Ventilsteuerung	mecanismo de válvulas
vacuum	vide, dépression	Vakuum, Unterdruck	vacio, vacuómetro
washer	rondelle	Unterlegscheibe	aradela
water	eau	Wasser	agua
water pump	pompe à eau	Wasserpumpe	bomba de agua
wear strip	bande d'usure	Verschleissstreifen	plancha de desgaste
wheel	roue	Rad	rueda
wheel cylinder	cylindre de roue	Radbremszylinder	cilindro de rueda
wiper	racleur	Wischer, Abstreifer	limpiaparabrisas
wire	fil	Draht, Leitung	alambre, cable
wire harness	faisceau de fils	Kabelbaum	mazo de cables
wire marker	marquer de fil	Kabelmarkierung	marcador de alambre
worm	vis sans fin	Schnecke	tornillo sin fin
wrap	revêtement, enveloppe	Hülle	envolver, envoltura
yoke	chape	Gabelgelenk, Joch	horquilla

A

Alarm, Back-Up	3.26
Arm, Steering	3.8
Arm, Welded Pump	3.25
Assembly:	
Brake/Disconnect	3.27
Engine	3.23
Filter, High Pressure	3.26
Rod Brake Pedal	3.16
Tire & Wheel	3.2, 3.9, 3.10, 3.11
Transmission/Pump	3.25

B

Bar, Brush Mount	3.2, 3.35
Bar, Spray	3.11, 3.12, 3.14
Battery	3.22, 3.23
Bearing, 4 Bolt Flange, Front Fork	3.6, 3.8, 3.9
Belt, Seat	3.21
Bolt:	
1/2 x 1" GR8	3.15
1/2 x 2 1/4" GR8	3.25
1/2 x 3 1/4" GR8	3.8
1/2 - 13 x 1 1/2" NC GR8Z	3.9
5/8 x 2 1/4" GR8Z	3.6
Eye, 3/8 - 16 x 2"	3.24
Eye, Brake Extension Spring	3.3
Shoulder, Pedal, 3/4 - 10 x 4" NC	3.16
Boot, Forward/Reverse Valve	3.10
Bracket, Seat Belt Mounting	3.21
Bracket, Tail Light Harness	3.22

Brake Hub:

Backing Plate	3.41
Basic Hypac	3.41
Bearing & Race, Inner #14 & #15, Set	3.40
Bearing & Race, Outer #2 & #3, Set	3.40
Bolt, Wheel Hub	3.41
Brake Arm Shaft Assembly	3.41
Brake/Disconnect Hub Assembly	3.41
Brake Shoe	3.41
Brake Shoe Assembly	3.41
Gasket, Face Seal "A" Mount 4 Bolt	3.41
Handle, Shaft	3.40
Housing w/Brake	3.40
Hub - Drum	3.41
Key, 0.312 sq. x 1" Long	3.40
Locknut	3.40, 3.41
Lock Washer, Inner	3.40, 3.41
Ret. Ring - Handle	3.40
Ret. Ring - Shaft	3.40
Ret. Ring - Sleeve	3.40
Ret. Ring - Spring	3.40
Seal, Oil - Bearing	3.40
Seal, Oil, Shaft	3.40
Shaft	3.40
Sleeve, Brake Disconnect Hub	3.40
Spindle, Brake, Disconnect Hub	3.40, 3.41
Spring	3.41
Spring, Shaft	3.40
Steel Drum	3.41
Washer, Spring	3.40
Washer, Tongued	3.40
Wrench, Hypac Hub Mount Hub	3.41

Broom:

Bolt, 1/2" - 13 x 1 1/2"	3.27
Bolt, 3/4" - 10 x 3"	3.34
Dust Cap	3.32
Flat Washer SAE, 1/2"	3.27
Flat Washer SAE, 3/4"	3.34
Flat Washer USS, 3/4"	3.34
Kit P/N - Bearings, Hub and Dust Cap	3.32
Lock Nut, 3/4"	3.34
Lock Washer, 1/2"	3.27
Mount Plate w/Stops	3.34
Nut, 1/2 - 13, Heavy Hex	3.31
Slotted Nut, P/N, 3/4"	3.32
Spindle, P/N	3.32
Washer, P/N, 3/4" SAE	3.32

Broom, Core:

Bearing/Race	3.32
Body, 4 Bolt Thru Mounting	3.50

Broom, Core (continued):

Cap, Plate	3.31
Cotter Pin, 1/8" x 1 3/4"	3.32
Ring	3.50
Rings, Thick	3.31, 3.32
Rings, Thin, Center	3.31, 3.32
Plate, End	3.31
Seal	3.32
Seal Kit, Drive Motor, Brush	3.50
Seal, O-Ring, Drive Motor, Brush	3.50
Seal/Retainer Assembly	3.50
Seal, Square Ring or Motor	3.50
Tube	3.31, 3.32
Washer, Thrust # 11	3.50
Washer, Thrust Hard #13	3.50
Washer, Thrust Drive Motor	3.50

Brush Bar:

Bolt, 1/2" - 13 x 1"	3.35
Flat Washer SAE, 1/2"	3.35
Lock Nut, 1/2" - 20	3.35
Long Pin, 1" Dia x 4 1/8"	3.36
Long Pin, 1" Dia x 5 1/8"	3.36
Long Roll Pin, 1/4" x 1 1/2"	3.36
U-Bolt, 1/2" x 3" x 6"	3.35

Brush Core:

6 Foot	3.38
8 Foot	3.38
Block Seal for Brush Motor	3.38
Bolt, 3/8" x 3/4"	3.38
Bolt, 1/2" - 13 x 1 1/2"	3.37
Bolt, 1/2" - 13 x 2 1/2"	3.37
Cap Plate	3.38
Drive Motor Block	3.38
Flat Head Bolt, 1/2" x 1 1/4"	3.38
Flat Washer SAE, 1/2"	3.37
Key Retainer Washer	3.38
Lock Nut, 1/2"	3.37
Lock Washer, 1/2"	3.37
Motor	3.37
Motor Mount, LH	3.37
Motor Mount, RH	3.37
Set Screw, 5/16" - 18 x 1/2"	3.38
Straight Key	3.38
Brush Hood, 6 Foot	3.27
Brush Hood, 8 Foot	3.27
Brush Lift Cylinder	3.36

C

Cable, Ground Strap, 12" Eye x Eye	3.22
Cable, Negative Battery	3.22
Cable, Positive Battery	3.22
Cable, Throttle	3.17, 3.18
Cap, Locking, Fuel/Hydraulic Filler	3.8, 3.10, 3.11, 3.12
Cap, Steering Wheel	3.17
Cap, Water Tank Fill	3.8
Chain, Safety, Tow-Bar	3.4, 3.5
Clamp, 19/32" Spray Orifice	3.13, 3.14
Clamp, Spray Bar to Push Lock Hose	3.13, 3.14
Clevis, Weldable, 5/16 - 24	3.27
Coupler, Tow Bar Hitch, 2"	3.4, 3.5
Cylinder, Brush Angle	3.2, 3.15
Cylinder, Brush Lift	3.15, 3.16
Cylinder, Steering	3.2, 3.8, 3.9, 3.11
Cylinder, Tow-Bar Lift	3.4, 3.5

D

Decal:

2" Ball Hitch	5.2
American Flag	5.1, 5.2
Broom Angle	5.5
Broom Rotation	5.5
CAUTION, Do Not Use Ether	5.2
CAUTION, Set Parking Brakes	5.3
DANGER, Before Starting This Machine	5.5
Forward/Neutral/Park/Reverse	5.3
Maintenance	5.1
On/Water/Fogger/Off	5.5
Read Owner's Manual Before Operating	5.3
Terramite	5.1, 5.2

INDEX

Decal (continued):

Tow Bar Connection Instructions	5.2
Use 10W API SG CD	5.1, 5.2
WARNING, Brush Setting	5.1, 5.2
WARNING, Disconnect Right and Left Lockout Hubs	5.2, 5.4
WARNING, Set Forward/Reverse Lever	5.5
WARNING, Stand Clear, Flying Objects	5.1, 5.2
WARNING, Stand Clear, Pinch Point	5.1, 5.2, 5.4
WARNING, Towing Instructions	5.4
WARNING, Use Protective Eye Wear	5.5

E

F

Filter:

Air	3.23
Base	3.45
Bolt 1/4" - 20 x 5/8 GR8Z	3.45
Bowl	3.29
Element	3.29, 3.45
Fitting, 1/2 mp x #8MVIC 90°	3.45
Fitting 3/4" mp x 1/2 F Reducer	3.45
Fitting, #8MVIC x #8MP Straight	3.45
Fitting, "T", mp Across 3/4 FP Center	3.45
Housing Assembly	3.45
Hydraulic	3.9, 3.45
"O" Ring	3.29, 3.45
Relief Nut Assembly	3.45
Suction, Water-Pump	3.16

Fitting:

3/8 HBT 29 Brass, Waterline	3.10
1/2 MP x #8MJIC90°	3.15, 3.16, 3.18
1/2 MP x 3/8 HB90, Water Tank	3.3
1 1/4 O-Ring x 1" JIC90°	3.24
#6 O-Ring Plug	3.20
#6 O-Ring x #6MJIC Straight	3.20
#6 O-Ring x #6MJIC90°	3.25
#6 O-Ring x #6MJIC90° w/.016, Cylinder Hose, Tow-Bar Lift	3.4, 3.5
#6 O-Ring x #6MJIC45°(Forged)	3.20
#6 O-Ring x #8MJIC45°(Forged)	3.20
#8MB O-Ring x #6JIC90°, Tow-Bar Valve	3.5
#8MJIC "T"	3.18
#8MJIC x #8MP Straight	3.20
#8MJIC x #10 O-Ring 90° w/Check P	3.24, 3.25
#8 O-Ring x #6JIC90°, Tow-Bar Valve	3.5, 3.7
#8 O-Ring x #6JICM45°	3.20
#8 O-Ring x #8JICM45°	3.19, 3.20
#8 O-Ring x #8MJIC	3.24
#8 Swivel Nut Run "T"	3.19
#12 O-Ring x #8MJIC	3.24, 3.25
#12 O-Ring x #8MJIC90°	3.24
90° Water	3.30
Fuel Tank, 1/4FM x 1/4" FM90°	3.16
Hex Head, #8 Plug	3.20
"L" 1/4"	3.24, 3.25
Tee Brass Water	3.30

Front Fork:

4 Bolt Flange Bearing	3.28
Bolt, 1/2	3.28
Bolt, 5/8	3.28
Front Fork	3.3, 3.28
Lock Nut, 1/2	3.28
Lock Nut, 5/8	3.28
Washer, 1/2	3.28
Washer, 5/8	3.28
Steering Arm	3.28
Frame	3.2

G

Gauge, Fuel/Oil/Temp/Volts	3.20
Gauge, Hourmeter/Tachometer Cluster	3.20
Gear Pump, Key, Coupler, Cessna	3.47
Gear Pump, Kit, Seal, Double Gear Pump	3.47
Gear, Steering	3.2, 3.20

Ground Drive:

Bolt, 1/2" - 20 x 1/2" GR8	3.46
Brake Hub Assembly	3.46
Gasket, Motor-to/Lockout, Wheel Drive	3.46
Motor, Drive, Wheel, w/Relief	3.46
Nut, Lug, 1/2" ID x 13/16"	3.46
Sleeve, Brake Disconnect Hub	3.46
Washer, 1/2", Split Lock	3.46

H

Handle, Brake	3.2, 3.21
Handle, Broom Lift/Angle Valve	3.17
Handle, Tow-Gar Valve	3.7
Harness, Electrical, Tow-Bar	3.4, 3.7
Head, Filter, Blocked-By-Pass	3.15
Head, Filter, 25PSI, Relief	3.15
Hold Down, Battery	3.22
Hood Assembly w/Lights	3.22
Hood, Engine	3.22

Hose:

#8FJIC x #8JICF90°, 6 Ft. Brush (L & R Side)	3.13, 3.14
#8FJIC x #8JICF90°, 8 Ft. Brush (L & R Side)	3.13, 3.14
3/8", Push Lock	3.15
3/8 x 4	3.29
3/8 x 9"	3.29
3/8 x 12", HY06-06FJ-06FJ9	3.26
3/8 x 16"	3.29
3/8 x 19"	3.29
3/8 x 30", #6FJIC Both	3.15, 3.19
3/8 x 31", #6FJIC Both, Cylinder, Tow Bar Lift	3.4, 3.5, 3.8, 3.11
3/8 x 37", #6FJIC Both, Cylinder, Tow Bar Lift	3.4, 3.5, 3.8, 3.11
3/8 x 48", #6FJIC Both	3.9, 3.15, 3.18, 3.19
3/8 x 74", #6FJIC x #6FJIC90°	3.9, 3.10
3/8 x 84", #6FJIC x #6FJIC90°	3.9, 3.10, 3.11
3/8 x 92", #8FJIC x #6FJIC - Kubota	3.7
3/8 x 96", #8 FJIC x #6FJIC - Deutz	3.7
3/8 (Left) x 65"	3.29
3/8 (Right) x 75"	3.29
1/2 x 10 1/2", FX08W/hy08	3.18
1/2 x 12", #8FMJICSTR Both	3.26
1/2 x 13", #8FJIC x #8FJIC90°	3.19
1/2 x 19 1/2", #8FJIC x #8FJIC90°	3.26
1/2 x 25", #8FJIC x #8FJIC45°	3.26
1/2 x 25", #8FMJIC Both	3.26
1/2 x 29", FX08W/hy08-08 FJ	3.18
1/2 x 36", #8FJIC x #8JICF90°	3.26
1/2 x 39", #8FJIC x #8JICF90°	3.9, 3.18, 3.19
1/2 x 54", #8FJIC x #8FJIC90°	3.9

I

J

K

Key, Ignition	3.18
Kit, Front Hub	3.10
Kit, Tow-Bar Coupler	3.4

L

Latch, Engine Hood	3.22
Lever, Brush Speed	3.17
Light, Stop/Turn/Tail	3.22
Link, Quick, 5/16"	3.16

M

Motor, Brush Core Drive	3.2, 3.9, 3.10
Mount, Brush Core Motor	3.13, 3.14
Muffler	3.23

N

New Gauge	3.20
New Kit	3.17

O

P

Panel, Cover, Rear, Engine	3.22
Panel, Top, Engine	3.21
Pedal, Brake	3.16

Pin:

- 1" x 2 1/8" Lg., Steering Cylinder 3.15
- 1" x 4 1/2" Lg., Top Broom Lift 3.15
- 1" x 5 1/8 Lg., Broom Lift 3.15
- Linch, Tow-Bar Pivot Pin 3.6
- Roll 1/4" x 1 1/2" 3.15
- Tow-Bar 3.5, 3.6, 3.7, 3.8, 3.12
- Tow-Bar Lift/Steering Cylinder 3.4, 3.5, 3.8, 3.9, 3.11
- Tow-Bar - Lower Locking 3.5, 3.11, 3.12
- Tow-Bar - Upper Locking 3.5, 3.7, 3.8, 3.11, 3.12

Pipe, Air Inlet, Deutz 3.2

Pivot:

- Bearing Weldment 3.33
- Bracket Weldment 3.33
- Bolt, 1/4" - 20 x 2 1/4" 3.33
- Bolt, 5/8" - 18 x 1 1/2" 3.33
- Flat Washer, 5/8" 3.33
- Lock Nut, 1/4" 3.33
- Lock Washer, 5/8" 3.33
- Washer, 1 1/4" 3.33

Plug, Drain, Water Tank 3.3, 3.23

Pre-Cleaner Assembly 3.3

Pump, Main Transmission 3.24, 3.25

Pump, Tandem, Eaton 3.24, 3.25

Q

R

- Rod, Bellcrank Control, 4 5/8" L 3.27
- Rod, Brake Lever, Plated 3.26

S

Seat 3.2

Set, Arm Rest 3.21

Spray Bar:

- 6 Foot 3.39
- 8 Foot 3.39
- Barbed Tee Water Fitting, 3/8" 3.39
- Bolt, 3/8" - 16 x 1 1/4", Zinc Plated 3.39
- Brass Cap 3.30, 3.39
- Brass Seal 3.30, 3.39
- Brass Water Fitting, 90° 3.39
- Brass Water Fitting, Tee 3.39
- Check Valve Strainer 3.30, 3.39
- Clamp w/Screw 3.30, 3.39
- Flat Washer, 3/8" 3.39
- Lock Washer, 3/8" 3.39
- Nut 3.30

Spray Hose, 3/8" (6 - 10 1/2", 2 - 4 1/2") 3.39

Spray Hose Clamp 3.39

Spray Kit Items 3.30

Spring, Brake Extension, 3/4 OD 3.3

Spring, Forward/Reverse Pedal 3.24

Spring, Large, Frame to Broom 3.15

Strainer, Drain, Water Tank 3.3

Strap, Front Holding, Water Tank 3.3

Strap, Rear Holding, Water Tank 3.3

Switch, Ignition 3.17, 3.18

T

"T" Block 3.26

Tank, Water 3.2

Transmission: 3.48, 3.49

- Adapter Assembly
- Backplate Assembly
- Bearing Race
- Camplate
- Check Valve Assembly
- Cover Plate
- Gerotor and Coupler
- Housing, Gasket
- Key
- O-Ring in Back
- O-Ring, 1/16" x 3 1/4"
- O-Ring, 3 3/32" x 4 1/64"
- O-Ring, Molded
- O-Ring, 1/16" x 7/16"
- Plate, Valve
- Poppet Filter Relief
- Back Up Washer
- Bearing
- Bearing, Thrust
- Cap Screw
- Coupler
- Drive Shaft
- Housing Assembly
- Inner Race
- O-Ring 3 3/32" x 7/8" ID, Back Plate
- O-Ring, 1/16" x 3/8"
- O-Ring, 3/32" x 15/16", Outer Pintle
- O-Ring, 3 3/32" x 7/8"
- O-Ring, Outer Pintle
- Pin
- Plug Assembly
- Relief Valve Assembly

Transmission (Continued):

- Retaining Ring
- Rotating Rebuild Kit, Cessna
- Seal Cover
- Seal, Pintle
- Shaft Seal
- Spreader
- Spring Retainer
- Steel Ball
- Washer

- Rotating Kit Assembly
- Screws
- Seal Repair Kit
- Separator Plug
- Sleeve Cover
- Spring
- Spring, Transmission, Relief Valve
- Trunnion Cover

U

- U-Bolt, w/Nuts "U", 1/2NF x 31W x 6"L 3.15

V

- Valve, Control, Variable, Broom RDRS-105-16 3.20
- Valve, Forward/Reverse 3.10, 3.26
- Valve, Lift/Angle 3.19, 3.20
- Valve, Tow Bar 3.2, 3.5, 3.7, 3.8, 3.10

W

- Wafer, Poly, Brush 3.1
- Wafer, Wire, Brush 3.1
- Water Hose Connector 3.29
- Water Pump 3.29
- Water Pump Filter 3.29
- Water Spray Orifice 3.30, 3.39
- Water System, 3/8 Crimp Clamp 3.29
- Water System, 3/8 Mnpt x 1/2 Mnpt Step Nipple 3.29
- Water System, 3/8 Mnpt x 90° x 3/8 Barb 3.29
- Water System, 3/8 Plastic "T" 3.29
- Water System, 1/2 Mnpt x 3x8 Barb 3.29
- Water System, 90° Body 3.29
- Water System, "T" Body 3.29
- Water Tank 3.29
- Water Tank Cap 3.29
- Water Tank Drain Plug 3.29
- Wheel, Steering 3.2, 3.17

X

Y

- Yoke, Lever, Brake, 1/2" - 20NF 3.16

Z

SAMPLE Limited New Product Warranty

WE WARRANT TO THE ORIGINAL CONSUMER/ PURCHASER THAT EACH NEW PRODUCT SOLD BY US WILL BE FREE FROM MANUFACTURING DEFECTS IN NORMAL SERVICE USE FOR A PERIOD OF ONE (1) YEAR FROM DATE OF PURCHASE.

Our obligation under this warranty is expressly limited, solely at our option, to the replacement or repair at the premises of Terramite Corporation, 600 Goff Mountain Road, Charleston, West Virginia 25356, or at a service facility designated by us, of such part or parts as inspection shall disclose to have been defective. This warranty does not apply to defects caused by casualty or unreasonable use (including faulty repairs by others and failure to provide reasonable and necessary maintenance) nor to ordinary wear and tear, while in the possession of the consumer/purchaser.

This warranty is for replacement or repair of defective parts only, and does not provide for replacement of complete products due to a defective part or parts nor does it cover any charges of whatever kind in connection with the replacement of any such defective parts.

We shall not be responsible for special, indirect, incidental or consequential damages of any kind including, but not limited to, labor costs or transportation charges in

connection with the replacement or repair of defective parts.

Components such as engines, pumps and batteries which are supplied by other manufacturers, are warranted by the manufacturer's nearest "Factory Service Center" for repair or replacement of those items. However, when necessary, the manufacturer will act as your agent to secure adjustment.

To obtain warranty service, purchaser must bring the product to an authorized Terramite Service facility. For the facility nearest you, contact Terramite Corporation, P.O. Box 7146, Charleston, WV 25356 or telephone (304) 776-4231.

This warranty gives you specific rights and you may have other rights which vary from state to state. This warranty is in lieu of any other warranty, whether written, verbal, expressed or implied and may not be modified or changed by Terramite Distributors or Dealers. This warranty shall be null and void unless the section below has been filled in and the manufacturer's copy of this document is returned to Terramite Corporation, P.O. Box 7146, Charleston, WV 25356 within ten (10) days of the date of purchase by the original owner.

MODEL# _____ SERIAL# _____ ENGINE# _____
 PURCHASED FROM _____ CERTIFICATE OF ORIGIN# _____
 NAME OF PURCHASER _____
 ADDRESS _____
 PHONE (____) _____ CERTIFICATE OF ORIGIN# _____
 TYPE OF BUSINESS _____
 IS THIS YOUR FIRST TERRAMITE? _____
 WHAT KIND OF SIMILAR EQUIPMENT DO YOU OWN? _____

 OPTIONS _____

 DATE OF PURCHASE _____ SIGNATURE _____

(ORIGINAL PURCHASER)

**Fill in the information requested above.
 This will be useful anytime you need to order parts.**

**This is only a SAMPLE of the Limited New Product Warranty
 provided with each new machine to the original owner.**