

UR-W547C

UNIC MINI-CRAWLER CRANE

UR-W547C provides maximum hook height of 18.2m with its seven section hydraulic boom.

Its compact 7 section long hydraulic boom provides the wide working radius of 17.83m and fantastic hook height of 18.2m. The long and yet compact boom gains a huge variety of lifting situation.

Max
18.2m

Hook height (Approx.)
(Above ground level)

with electric power unit



5020kg
Mass of crane

Max
4.05t
×2.5m
Lifting capacity

Max
17.83m
Working radius

Radio
remote
control



WORKING RANGE & NET RATED LOADS (kg)

Outrigger ● Max-extended NOT max-extended

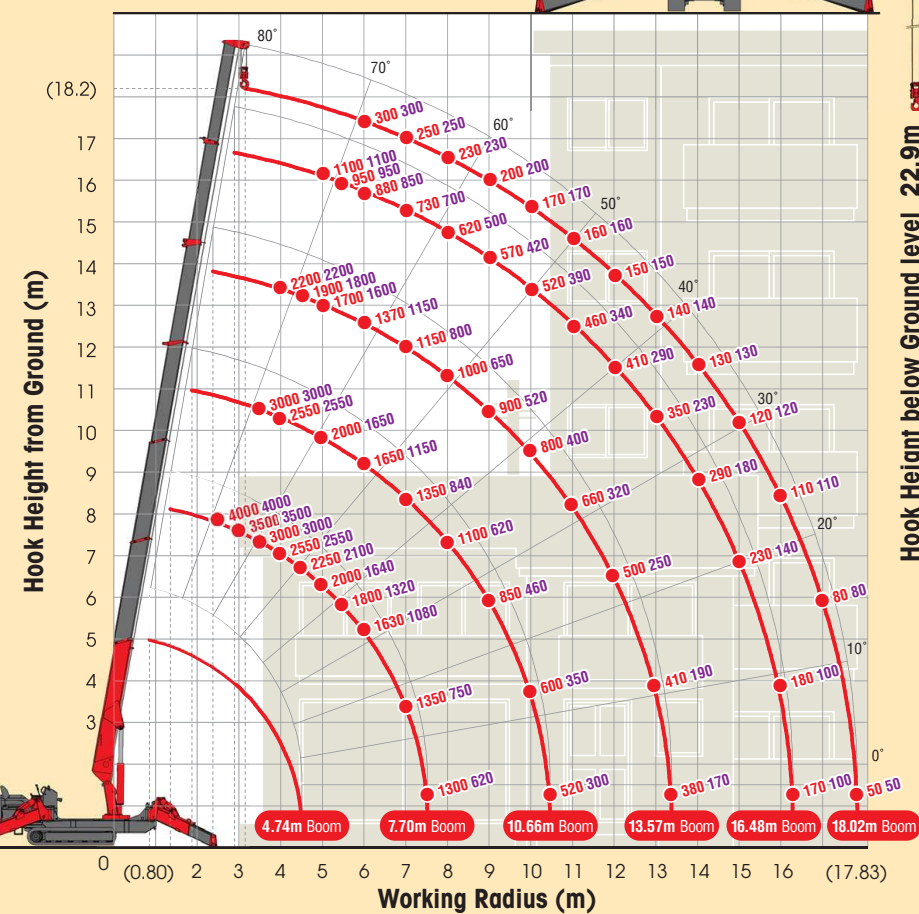

Automatic stop for overloading (KM-100)



Three colored lamp



Searcher hook assembly (Options)

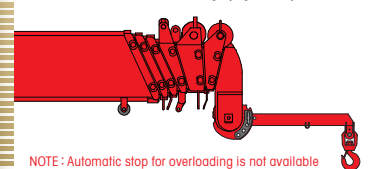

NOTE: Automatic stop for overloading is not available in combination with this Searcher hook assembly. For more information, contact your local UNIC distributor.

Length	800mm
Lifting capacity	Max. 500kg
Tilt angles	0°, 20°, 40°, 60°

SPECIFICATIONS

Crane model	UR-W547C2
Lifting capacity	Max. 4.05t at 2.5m
Working radius	Min. 0.80m, Max. 17.83m
Hook height (Approx.)	Above ground level
	Max. 18.2m
Below ground level	Max. 22.9m with 4-part line
	Min. 3.99m to Max. 18.02m
Boom	Length
	Extending speed [with electric power unit]
	Raising angle / speed [with electric power unit]
	Structure
	Single line speed [with electric power unit]
Winch	Hook speed [with electric power unit]
	Structure
	Wire rope
	Hook block
Slewing	Range
	Speed [with electric power unit]
Hydraulic pump	Structure
	Rated pressure
Hydraulic oil tank capacity	Rated delivery
	Rated revolution
Safety devices	Pressure relief valve for hydraulic circuit / Counterbalance valves for boom raising and boom telescoping cylinders / Pilot-operated check valves for outrigger cylinders (Horizontal)
	Double pilot-operated check valves for outrigger cylinders (Vertical) / Boom angle indicator with load indicator / Hook safety latch / Automatic mechanical brake for winch / Automatic stop for overwinding / Overwinding alarm / Automatic stop for leaving minimum wire rope / Emergency stop button / Inter-lock device of crane and crawling levers / Inter-lock device of crane and outriggers / Level / Automatic stop for overloading (KM-100) / Digital load meter / Three colored lamp / Headlight / Boom outrigger monitor lamp

OUTRIGGER POSITIONS

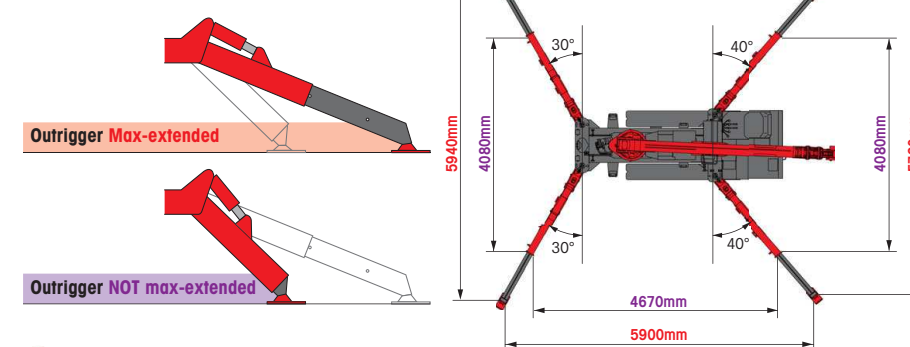

CRAWLING GEAR

Crane model	UR-W547C2
Crawling speed [with electric power unit]	0-3.0 km/h, forward / backward [50Hz] 0-1.3 km/h [60Hz] 0-1.5 km/h
Hill climbing ability	23°
Tread length	1750mm
Ground contact pressure [with electric power unit]	47.0 kPa [0.48 kg/cm ²] 48.1 kPa [0.49 kg/cm ²]
Engine manufacturer / model	Yanmar / 3TNV76
Displacement	1115cc
Maximum output	15.17kW(20.6PS) / 2500 rpm, Rated output
Fuel	Diesel
Fuel tank capacity	40 liters
Steering	Hydraulic drive independent of left / right
Starter	Starter motor

DIMENSIONS

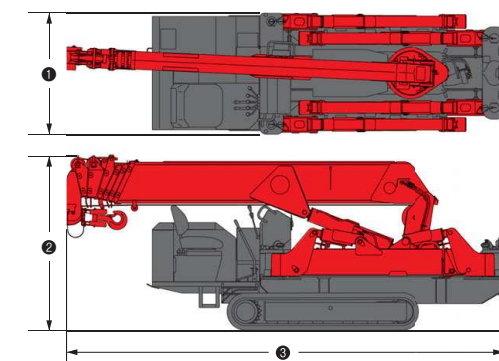

Crane model	UR-W547C2
1 Total width	1380mm
2 Total height	1980mm
3 Total length	4955mm
Mass of crane	5020kg [5170kg] [with electric power unit]

Electric power unit specifications

Rated power	7.5kW (3-phase 4 poles)
Voltage	AC 200V or 400V (50Hz / 60Hz) 3 phase 4P

*Not included any cables.

Standard equipments and Options

UNIC MINI-CRAWLER CRANE

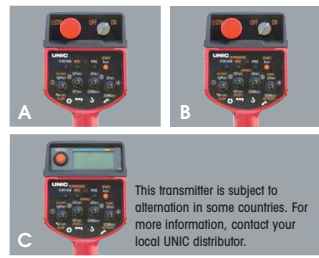

1 Radio remote control
 A W094C, W295C
 B W376C, W546C, W547C, W706C
 C W1006C



2 Cable remote control



3 Load meter



4 Digital load meter
 Load indication is each 20kg (0.02t).



5 Automatic stop for overloading
 KM-100 W376C, W546C, W547C



6 Automatic stop for overloading
 ML-300 W706C



7 Safe load indicator

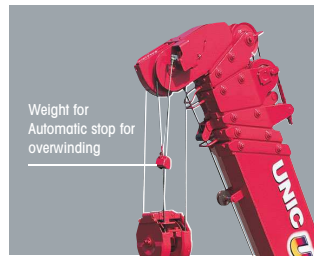

8 Automatic stop for overwinding



9 Automatic stop for leaving minimum wire rope



10 Emergency stop button
 A W094C, W295C
 B W376C, W546C, W547C, W706C, W1006C

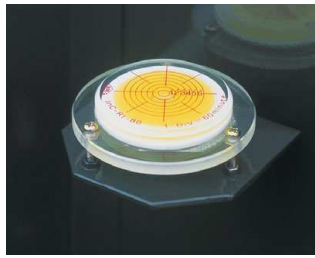

11 Level

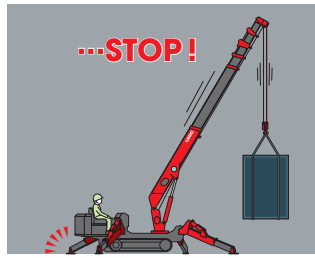

12 Turn over prevention device

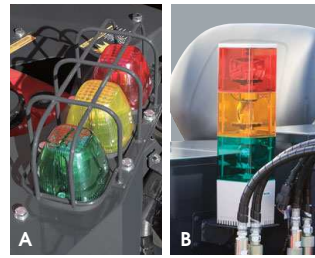

13 Three colored lamp
 A W295C
 B W376C, W546C, W547C, W706C, W1006C



14 Boom outrigger monitor lamp

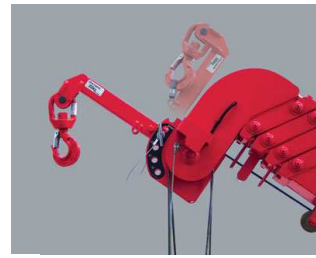

15 Searcher hook assembly



16 Fly jib assembly



17 Single line hook



18 Working light



19 Headlight



20 Outrigger mats



21 Black crawler belt



22 White crawler belt
23 White crawler belt (as spare)

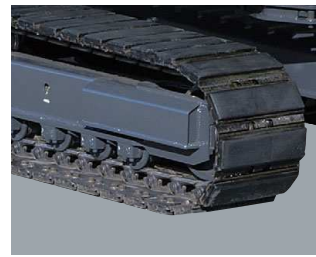

24 Rubber Pad



25 20M cable for motor (200V)
26 20M cable for motor (400V)

STANDARD EQUIPMENTS / OPTION [★ Standard ● Option — Not available]

Crane model	UR-W094C		UR-W295C		UR-W295C1		UR-W376C2		UR-W546C2		UR-W547C2		UR-W706C2		UR-W1006C2		Crane model
	UR-W094CP2E	UR-W295CP2A	UR-W295CP2AM	UR-W295C1A	UR-W295C1AM	UR-W376C2A	UR-W376C2AM	UR-W546C2A	UR-W546C2AM	UR-W547C2A	UR-W547C2AM	UR-W706C2A	UR-W706C2AM	UR-W1006C2A	UR-W1006C2AM		
Engine manufacturer / model	Mitsubishi / GB300LE	Mitsubishi / GB400LE	Mitsubishi / GB400LE	Kubota / Z482-E3B	Kubota / Z482-E3B	Yanmar / 3TNV76	Yanmar / 3TNV76	Yanmar / 3TNV76	Yanmar / 3TNV76	Yanmar / 3TNV76	Yanmar / 3TNV76	Mitsubishi / S4L2	Mitsubishi / S4L2	Yanmar / 4TNV88	Yanmar / 4TNV88	Engine manufacturer / model	
Fuel	Petrol	Petrol	Petrol	Diesel	Diesel	Diesel	Diesel	Diesel	Diesel	Diesel	Diesel	Diesel	Diesel	Diesel	Diesel	Fuel	
Electric motor	—	—	AC 200V or 400V	—	AC 200V or 400V	—	AC 200V or 400V	—	AC 200V or 400V	—	AC 200V or 400V	—	AC 200V or 400V	—	AC 400/400-440V	Electric motor	
1 Radio remote control	★	★	★	★	★	★	★	★	★	★	★	★	★	★	★	1 Radio remote control	
2 Cable remote control	●	●	●	●	●	●	●	●	●	●	●	●	●	●	●	2 Cable remote control	
3 Load meter	★	★	★	★	★	—	—	—	—	—	—	—	—	—	—	3 Load meter	
4 Digital load meter	—	●	●	●	●	★	★	★	★	★	★	★	★	★	★	4 Digital load meter	
5 Automatic stop for overloading (KM-100)	—	●	●	●	●	★	★	★	★	★	★	—	—	—	—	5 Automatic stop for overloading (KM-100)	
6 Automatic stop for overloading (ML-300)	—	—	—	—	—	—	—	—	—	—	—	★	★	—	—	6 Automatic stop for overloading (ML-300)	
7 Safe load indicator	—	—	—	—	—	—	—	—	—	—	—	—	—	—	—	7 Safe load indicator	
8 Automatic stop for overwinding	★	★	★	★	★	★	★	★	★	★	★	★	★	★	★	8 Automatic stop for overwinding	
9 Automatic stop for leaving minimum wire rope	★	★	★	★	★	★	★	★	★	★	★	★	★	★	★	9 Automatic stop for leaving minimum wire rope	
10 Emergency stop button	★	★	★	★	★	★	★	★	★	★	★	★	★	★	★	10 Emergency stop button	
11 Level	★	★	★	★	★	★	★	★	★	★	★	★	★	★	★	11 Level	
12 Turn over prevention device	—	★	★	★	★	●	●	—	—	—	—	—	—	—	—	12 Turn over prevention device	
13 Three colored lamp	—	●	●	●	●	★	★	★	★	★	★	★	★	★	★	13 Three colored lamp	
14 Boom outrigger monitor lamp	—	—	—	—	—	★	★	★	★	★	★	★	★	★	★	14 Boom outrigger monitor lamp	
15 Searcher hook assembly	—	●	●	●	●	●	●	●	●	●	●	●	●	●	●	15 Searcher hook assembly	
16 Fly jib assembly	—	●	●	●	●	●	●	●	●	●	●	●	●	●	●	16 Fly jib assembly	
17 Single line hook	—	●	●	●	●	—	—	—	—	—	—	●	●	●	●	17 Single line hook	
18 Working light	●	●	●	●	●	●	●	●	●	●	●	●	●	●	●	18 Working light	
19 Headlight	—	—	—	—	—	★	★	★	★	★	★	★	★	★	★	19 Headlight	
20 Outrigger mats	●	●	●	●	●	●	●	●	●	●	●	●	●	●	●	20 Outrigger mats	
21 Black crawler belt	★	★	★	★	★	★	★	★	★	★	★	★	★	★	★	21 Black crawler belt	
22 White crawler belt	●	●	●	●	●	—	—	—	—	—	—	—	—	—	—	22 White crawler belt	
23 White crawler belt (as spare)	●	●	●	●	●	●	●	●	●	●	●	●	●	●	●	23 White crawler belt (as spare)	
24 Rubber Pad	—	—	—	—	—	—	—	—	—	—	—	—	—	—	—	24 Rubber Pad	
25 20M cable for motor (200V)	—	—	●	—	—	—	—	—	—	—	—	—	—	—	—	25 20M cable for motor (200V)	
26 20M cable for motor (400V)	—	—	●	—	—	—	—	—	—	—	—	—	—	—	—	26 20M cable for motor (400V)	