

# Boom Lift

**UpRight**  
POWERED ACCESS



PRELIMINARY

- Working height up to 16.1m
- 7.5m working outreach
- Electric proportional controls
- 1.5m, 140° jib
- 2WD or 4WD rough terrain
- Ultra-tight inside turning radius of 0.6m
- Large 1.75m x 1.0m working platform
- 5 year structural warranty

**AB46E**  
**AB46RT**

# AB46E/46RT self propelled boom specifications

	AB46E 2WD	AB46RT 4WD
max. working height	16.1m	16.1m
max. platform height	14.1m	14.1m
max. working outreach	7.5m	7.5m
jib length	1.5m	1.5m
jib arc	140°	140°
platform capacity (SWL)	227kg	227kg
platform size - outside	1.0m x 1.75m	1.0m x 1.75m
platform rotation	140°	140°
turret rotation	360° non-continuous	360° non-continuous
width <b>A</b>	1.75m	2.0m
stowed height <b>B</b>	2.0m	2.13m
stowed length <b>C</b>	5.43m	5.43m
gross weight	6,486kg	6,650kg
gradeability	17°/30%	22°/40%
inside turning radius	0.60m	0.60m
outside turning radius	3.0m	3.0m
tail swing - stowed	0	0
cycle time to full height	66 secs	66 secs
ground clearance	152mm	330mm
max. drive speed - stowed	5.64km/h	8.5km/h
max. drive speed - elevated	0.8km/h	0.6km/h
tyres	high grip poly filled	high grip poly filled
power source	8 6V 350 Ah batteries	Kubota V1505 Diesel

Specifications subject to change without notice. Photos and diagrams in this brochure are for promotional purposes only. Refer to appropriate UpRight operators manual for detailed instructions on the proper use and maintenance.

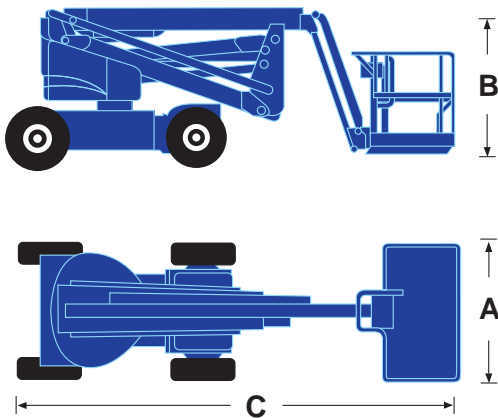

BP1, AB46 3/07

**UpRight**  
POWERED ACCESS

Vigo Centre, Birtley Road, Washington,  
Tyne & Wear, NE38 9DA, U.K.

Sales Tel: + 44 (0) 845 1550 057 • Spare Parts Tel: + 44 (0) 845 1550 058

[www.upright.com](http://www.upright.com)

## standard features

- Multi-function, variable speed platform controls
- Oscillating front axle (4WD model only)
- Proportional controls
- Power to platform
- Hour meter
- Battery charge indicator (electric only)
- Wide rough terrain tyres (4WD model only)
- 1 year parts/service
- 5 year structural warranty

## options

- Motion alarm
- Flashing amber beacon
- Diesel scrubber (Diesel models only)
- Special paint colours
- Environmental green oil

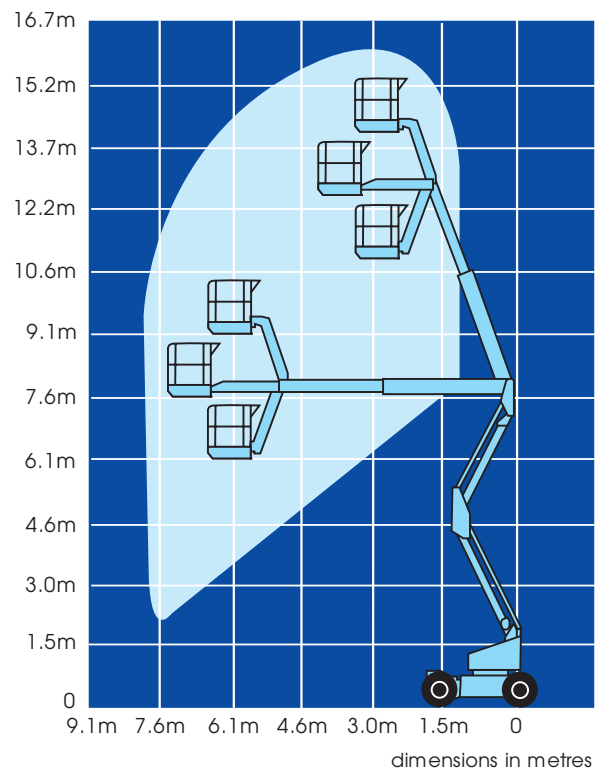

This product is available with the CE mark confirming compliance with all relevant European Machinery Directives

manufactured by

**UpRight**  
POWERED ACCESS