

Vertical Mast

UpRight
POWERED ACCESS



- 5.7m max. working height
- Ultra-compact design
- Drives through standard doorway or narrow aisles
- 227kg platform capacity
- Transportable in most passenger elevators
- Step-on / step-off platform
- Non-marking tyres

TM12

TM12 vertical mast specifications

TM12 VERTICAL MAST

max. working height A	5.7m
max. platform height B	3.7m
max. drive height	3.7m
platform capacity (SWL)	227kg
platform size (inside)	0.74m x 1.04m
width C	0.76m
stowed height D	1.7m
stowed length E	1.36m
gross weight	776kg
drive speed - max.	3.65km/h
with platform raised	1.0km/h
gradeability	14° / 25%
inside turning radius	0.37m
ground clearance	76mm
lift speed - raise/lower	18 seconds / 25 seconds
drive system	dual front hydraulic motors
tyres	305mm dia. solid rubber, non-marking
battery charger	90V - 240V - 25 amp automatic
parking brake	2 wheel, spring-applied, hydraulically-released with manual overdrive
control system	one-hand proportional controls
power source	24V 4hp DC electric motor 4-220 Ah batteries

Specifications subject to change without notice. Photos and diagrams in this brochure are for promotional purposes only. Refer to appropriate UpRight operators manual for detailed instructions on the proper use and maintenance.

The UpRight TM12 provides a safe, efficient means of working at height in restricted spaces typically encountered in offices, retail stores, hotels, public buildings or crowded industrial aisles. Its compact size also makes it ideal for applications such as stock picking and record storage retrieval. Operators simply step onto the platform, drive to the work location and elevate to the desired height. When the job is complete, the lift can be quickly lowered and returned to a convenient storage area.



standard features

- Proportional controls
- Drives at full height
- 24V DC 4hp electric motor provides clean, pollution-free power for indoor use
- Descent and tilt alarms
- High amp hour rating gives long usage between charges
- 25 amp charger for easy overnight re-charging
- Emergency lowering at chassis controls
- Non-marking, solid rubber tyres
- Crane lift points
- Selectable motion alarm
- 1 year parts and labour warranty
- 5 year structural warranty

options

- Overload alarm
- Special paint colours
- Environmental green oil

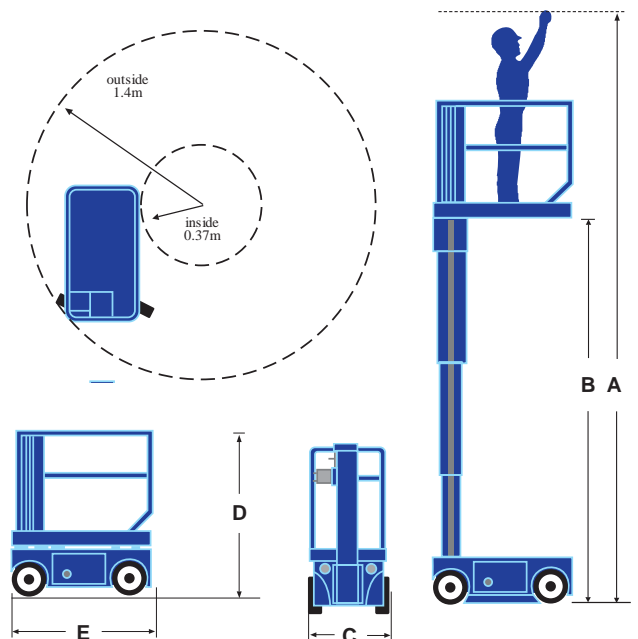

BP1 - TM12 10/06

UpRight
POWERED ACCESS

Vigo Centre, Birtley Road, Washington,
Tyne & Wear, NE38 9DA, U.K.

Sales Tel: + 44 (0) 845 1550 057 • Spare Parts Tel: + 44 (0) 845 1550 058

www.upright.com

CE This product is available with the CE mark confirming compliance with all relevant European Machinery Directives

manufactured by
UpRight
POWERED ACCESS