

2000/2250JBT
2500/2700JBT Cranes
Operating & Safety Manual

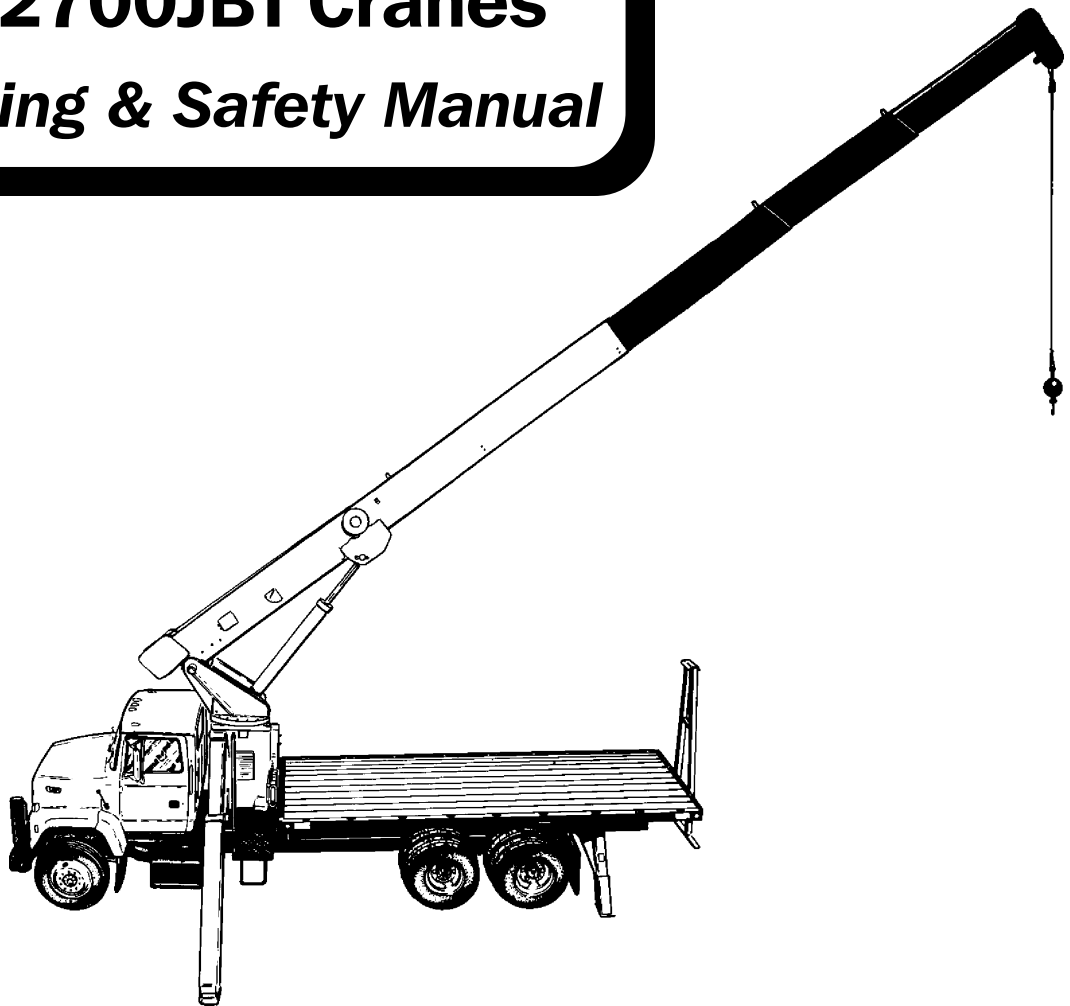

USTC, Inc.

*76 Bowman Road
York, PA 17404-8793*

*3000 S. Austin Ave
Georgetown, TX 78627-1609*

Sales: (717) 505-8800
Sales Fax: (717) 505-8811
Service: (800) 556-8280
Service Fax: (717) 505-8812

Sales: (512) 942-3000
Sales Fax: (512) 863-3776
Service: (512) 942-3022
Service Fax: (512) 942-3094

FORWARD

The purpose of this manual is to provide the customer with the operating procedures essential for the promotion of safe and proper machine operation for its intended purpose. It is important to over-stress proper usage. All information in this manual should be **READ** and **UNDERSTOOD** before any attempt is made to operate the machine.

SINCE THE MANUFACTURER HAS NO DIRECT CONTROL OVER MACHINE APPLICATION AND OPERATION, CONFORMANCE WITH GOOD SAFETY PRACTICE IN THIS AREA IS THE RESPONSIBILITY OF THE USER AND HIS OPERATING PERSONNEL.

ALL PROCEDURES HEREIN ARE BASED ON THE USE OF THE MACHINE UNDER PROPER OPERATING CONDITIONS, WITH NO DEVIATIONS FROM THE ORIGINAL DESIGN. ALTERATION AND/OR MODIFICATION OF THE MACHINE IS STRICTLY FORBIDDEN WITHOUT WRITTEN APPROVAL FROM USTC, INC.

REMEMBER, EQUIPMENT IS ONLY AS SAFE AS THOSE WHO OPERATE IT!

Since safety of personnel and proper use of the machine are of primary concern, statements are used throughout this manual to emphasize certain areas. The following definitions indicate how a statement will appear in this manual.

Whenever this symbol is seen in this manual or on the machine, personnel safety is a concern. Take time to read and understand these statements!

 **DANGER: INDICATES AN IMMINENTLY HAZARDOUS SITUATION WHICH, IF NOT AVOIDED, WILL RESULT IN DEATH OR SERIOUS INJURY.**

 **WARNING: INDICATES A POTENTIALLY HAZARDOUS SITUATION WHICH, IF NOT AVOIDED, COULD RESULT IN DEATH OR SERIOUS INJURY.**

 **CAUTION: INDICATES A POTENTIALLY HAZARDOUS SITUATIONS WHICH, IF NOT AVOIDED, MAY RESULT IN MINOR OR MODERATE INJURY. IT MAY ALSO BE USED TO ALERT AGAINST UNSAFE PRACTICES.**

IMPORTANT: Indicates a situation which may cause machine damage if not correctly followed.

Note: Provides information which may be of special interest.

TABLE OF CONTENTS

SECTION 1 – SAFETY PRECAUTIONS

General 1-1

 Load Lifting Safety 1-3

 Load Handling Safety 1-4

 Outrigger/Stabilizer Safety 1-4

 Operating Safety 1-5

 Operating Area Safety 1-5

 Wire Rope Safety 1-6

 Driving Safety 1-6

SECTION 2 – PRE-OPERATIONAL CHECKS

Machine Inspection Requirements 2-1

Preparation for Use 2-1

Lubrication 2-1

Operator's Daily Checklist 2-3

Periodic Inspection 2-4

Transporting 2-5

 General 2-5

 Transport 2-5

SECTION 3 – OPERATION

Authorized Operating Personnel 3-1

Operating Characteristics and Limitations 3-1

 General 3-1

Control Placards 3-1

Capacities and Stabilization 3-1

Controls and Indicators 3-2

Outrigger Controls 3-3

 General 3-3

 Outrigger and Stabilizer Types 3-4

 Outrigger/Stabilizer-In-Motion 3-4

Boom Controls 3-5

 Rotation 3-5

 Telescope 3-5

 Hoist 3-5

TABLE OF CONTENTS (Cont.)

Burst-of-Speed 3-5

Lift 3-5

Indicators and Engine Controls 3-5

 Engine Stop Switch 3-5

 Ignition Switch 3-5

 Horn Switch 3-5

 Boom Angle Indicator 3-5

 Crane Level Indicator 3-5

 Throttle Control 3-5

 Drum Rotation Indicator 3-6

 Anti-Two-Block Device 3-6

 Overload System 3-6

 Load Moment Indicator System 3-7

Load Chart 3-7

 Lift Capacity Chart 3-7

 Weight Reduction for Load Handling Devices 3-8

 Hook Height Chart 3-8

 Area of Operation 3-8

Notes to Lifting Capacities 3-8

Operating the Crane 3-8

Work Site Selection 3-8

Preparation for Machine Operation 3-8

 Load Capacity Chart 3-8

 Danger, Warning, Caution and Instruction Placards 3-8

 Boom Length Marking Tape 3-8

 Notes to Lifting Capacities 3-8

Crane Functions 3-9

 Starting the Engine and PTO 3-9

 Setting A-Frame Outriggers and Stabilizers 3-9

 Setting Out-and-Down Outriggers and Stabilizers 3-9

 Setting the Stabilizer Jack 3-10

TABLE OF CONTENTS (Cont.)

Transporting the Crane 3-11

Wire Rope 3-11

Optional Equipment 3-11

Load Moment Indicator 3-11

Jib 3-11

 Jib Installation 3-12

 Telescope Jib 3-13

 Jib Stowage 3-14

Cable Reeving 3-14

 Single-Part Line Reeving 3-15

 Two-Part Line Reeving 3-15

 Three and Four-Part Line Reeving 3-16

 Five and Six-Part Line Reeving 3-16

 Additional Options 3-17

SECTION 4 – TROUBLESHOOTING

 Troubleshooting 4-1

APPENDIX

FIGURE LIST

1-1 *Read and Understand Your Manual* 1-1

1-2 *Electrical Hazard Working Vicinity* 1-2

1-3 *Never Wrap a Hoist Line Around Load* 1-3

1-4 *Never Use Boom for Anything Other Than Lifting Freely Suspended Loads* 1-3

1-5 *Never Lift Two Separate Loads at the Same Time* 1-4

1-6 *Keep Operating Area Clear of Personnel* 1-4

1-7 *Do Not Position Load or Boom Over Personnel* 1-5

1-8 *Allow No One to Ride the Load* 1-5

1-9 *Never Guess at the Load Weight* 1-6

1-10 *Avoid Overhanging Loads* 1-6

1-11 *Hand Signals* 1-7

2-1 *Lubrication Points* 2-2

2-2 *Anti-Two Block Switch Location* 2-6

3-1 *Outrigger and Stabilizer Locations* 3-2

3-2 *Operator's Control Station* 3-3

3-3 *Anti-Two-Block Switch Installation* 3-6

3-4 *Cable Socket and Wedge Installation* 3-10

3-5 *Telescoping Jib Pin Installation* 3-12

3-6 *Jib Stowage Pins* 3-13

3-7 *Reeving Configuration* 3-15

3-8 *Snatch Block Showing Five-Part Line* 3-17

TABLE LIST

1-1 *Safe Distances*..... 1-2

2-1 *Lubrication Points and Intervals* 2-2

GENERAL

⚠ WARNING: FAILURE TO COMPLY WITH SAFETY REGULATIONS LISTED IN THIS SECTION AND ON MACHINE IS A SAFETY VIOLATION WHICH MAY RESULT IN PERSONNEL INJURY OR DEATH TO PERSONNEL OR IN MACHINE DAMAGE.

This section prescribes proper and safe practices for major areas of machine usage. In order to promote proper usage of the machine, it is mandatory that a daily inspection routine be established by a qualified person and must be followed to ensure that the machine is safe to operate.

The user of the machine should not accept operating responsibility until this manual has been read and understood. Training in the operation of the machine, under the supervision of a qualified user, must also have been completed. If there is a question on application or operation, USTC, Inc. should be consulted before undertaking the intended use.

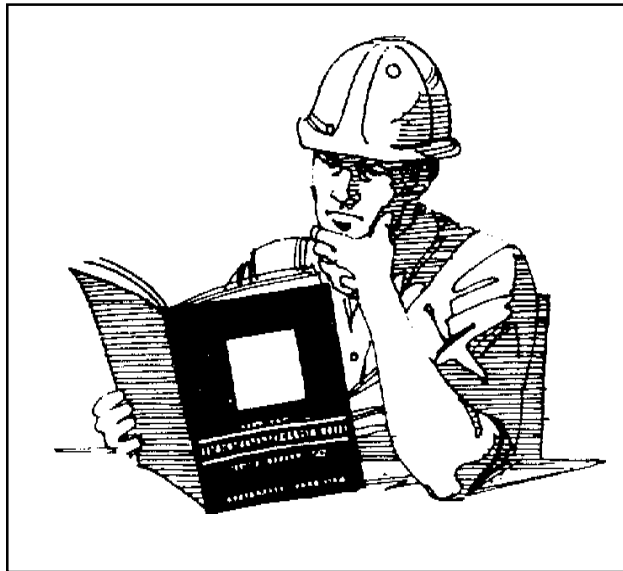

Figure 1-1. Read the Manual

⚠ WARNING: MODIFICATION OF THE MACHINE WITHOUT WRITTEN APPROVAL OF USTC, INC., OR CERTIFICATION BY A RESPONSIBLE AUTHORITY, THAT THE MACHINE IS AT LEAST AS SAFE AS ORIGINALLY MANUFACTURED IS A SAFETY VIOLATION AND IS STRICTLY PROHIBITED.

⚠ DANGER: WORKING IN THE VICINITY OF ELECTRICAL POWER LINES PRESENTS A VERY SERIOUS HAZARD AND SPECIAL PRECAUTIONS MUST BE TAKEN.

For purposes of this manual, the machine is considered to be working in the vicinity of power lines when any part of the crane, load line, load handling device, rigging or load, in any position can reach to within the minimum distance specified by local, state and federal regulations.

Federal regulations from 29CFR, PART 1926.550 for minimum distances are as follows:

Except where electrical distribution and transmission lines have been de-energized and visibly grounded at point of work or where insulating barrier, not a part of or an attachment to the equipment or machinery, have been erected to prevent physical contact with the lines, equipment or machines shall be operated proximate to power lines only in accordance with the following (see Table 1-1).

A person shall be designated to observe clearance of the equipment and give timely warning for all operations where it is difficult to maintain the desired clearance by visual means.

Cage-type boom guards, insulating links, or proximity warning devices shall not alter the requirements of any other regulation of this part, even if such device is required by law or regulation.

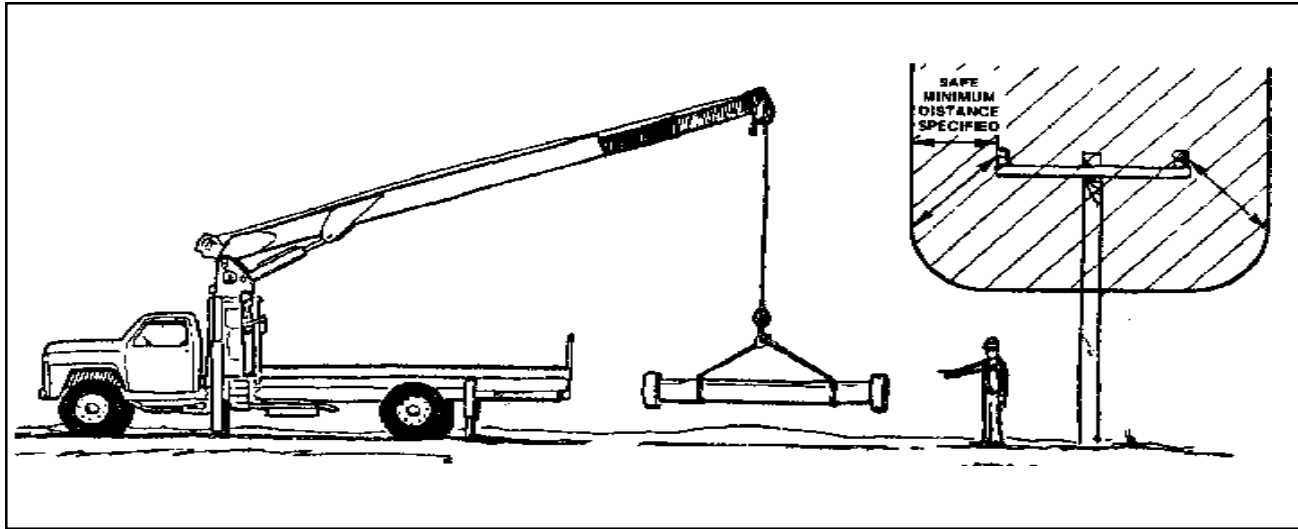

Figure 1-2. Electrical Hazard Working Vicinty

Any overhead wire shall be considered to be an energized line unless and until the person owning such line, or the electrical utility authorities, indicate that it is not an energized line and it has been visibly grounded.

⚠ DANGER: CONSIDER ALL LINES TO BE POWER LINES AND TREAT ALL POWER LINES AS ENERGIZED.

Operation of the boom and load over electric power lines is extremely dangerous. Avoid operating the crane, with or without a load, in this area.

Use a signal person. It is extremely difficult to judge distances between the crane and power lines. Do not rely on personal judgement. It is mandatory that a signal person be used when working in the vicinity of electrical lines.

The sole responsibility of the signal person is to observe, from the best vantage point, the approach of any part of

the crane or load to the power line. The signal person must be in direct communication with the operator and the operator must pay close attention to the signals.

⚠ DANGER: MAINTAIN SAFE CLEARANCE FROM ELECTRICAL LINES AND APPARATUS. ALLOW FOR BOOM SWAY, ROCK AND SAG AND ELECTRICAL LINE SWAY. MACHINE IS NOT INSULATED AND DOES NOT PROVIDE PROTECTION FROM CONTACT WITH, OR PROXIMITY TO, AN ELECTRICALLY CHARGED CONDUCTOR.

⚠ DANGER: EQUIPMENT MAY BECOME ELECTRICALLY CHARGED WHEN WORKING IN THE VICINITY OF HIGH FREQUENCY TRANSMITTERS.

⚠ DANGER: ALWAYS CONTACT THE OWNERS OF POWER LINES OR NEAREST ELECTRIC UTILITY BEFORE BEGINNING WORK IN THE VICINITY OF ELECTRIC POWER LINES. IT IS THE RESPONSIBILITY OF THE USER AND ELECTRIC UTILITY TO SEE THAT NECESSARY PRECAUTIONS ARE TAKEN.

⚠ WARNING: USE A SLOW OPERATING CYCLE TO ALLOW TIME TO REACT TO AVOID JUDGEMENT ERROR AND TO REACT TO SIGNALS.

Table 1-1 Safe Distances

VOLTAGE RANGE (PHASE TO PHASE)	MINIMUM SAFE DISTANCE
0-300 volts	Avoid Contact
Over 300 v to 50 kv	10 ft (3.05 m)
Over 50 kv to 200 kv	15 ft (4.60 m)
Over 200 kv to 350 kv	20 ft (6.10 m)
Over 350 kv to 500 kv	25 ft (7.62 m)
Over 500 kv to 750 kv	30 ft (10.67 m)
Over 750 kv to 1000 kv	45 ft (13.72 m)

LOAD LIFTING SAFETY

Do not exceed the load chart capacities or the load radius for the load being lifted. Always refer to the load chart before making any lifts. Under no circumstances should load chart capacities be exceeded. Never guess at the load weight. Determine weight of load before attempting the lift.

Do not depend on machine stability as a means to determine proper load capacity.

Rated loads on the main boom are based on both machine strength and stability with freely suspended loads. Overloading this machine may cause structural collapse or instability.

Ensure that the load is secured and properly rigged before starting any lifting operations.

Never lift two or more separately rigged loads at the same time even if combined load weight is within rated capacity.

Pre-plan all lifts and understand emergency procedures to be used should the unexpected occur.

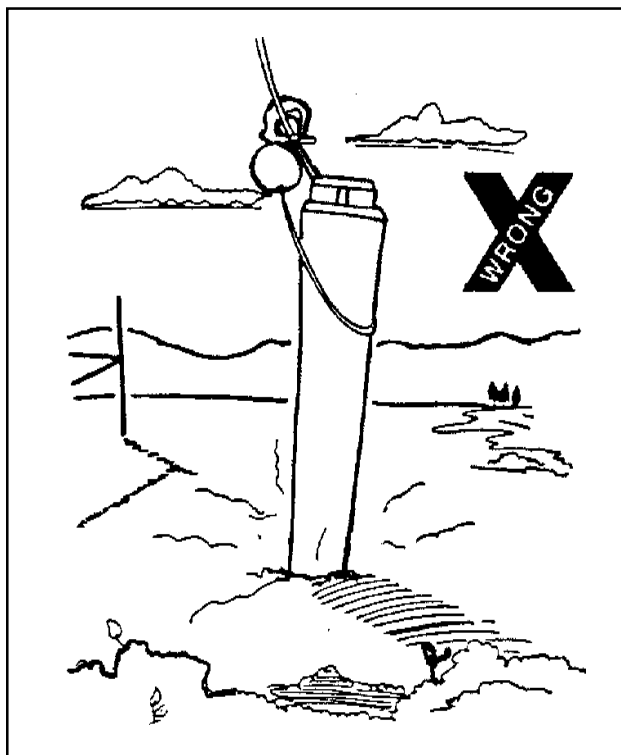

Figure 1-3. Never Wrap a Hoist Line Around Load

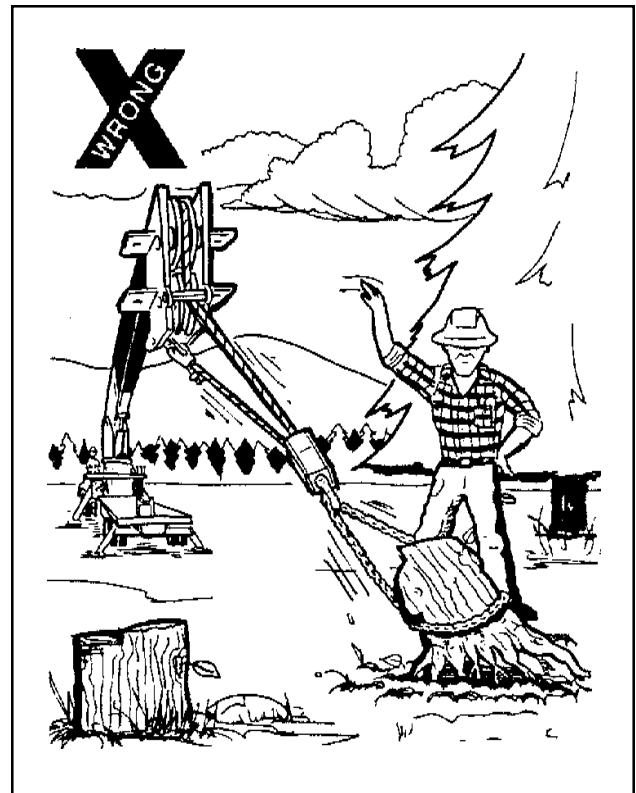

Figure 1-4. Never Use Boom for Anything Other Than Lifting Freely Suspended Loads

Never allow the load to strike any portion of the boom during a lift, or allow the boom to rest on or hit a building or any other object.

Before starting any lifting operations, check hoist brake operation by raising the load slightly and checking that brake does not slip.

Extreme caution must be used in performing lifts involving two or more cranes. Consult supervisor and a rigging specialist before attempting this type of lift. Such lifts must be supervised by a qualified third person.

A minimum of five (5) cable wraps must remain on hoist drum at all times.

Do not allow the hookblock to contact the boom tip by hoisting up or extending the boom. This condition, which is known as “two-blocking,” will cause load dropping, cable breakage, equipment damage and possible personnel injury.

Do not use the anti-two-block device to stop upward motion of the hookblock or other lifting device or as a substitute for good operator judgement and safe operating procedures.

Keep load handling devices a minimum of 12 inches below boom head.

The effects of wind loading should be considered during operation. The wind can impose substantial forces on the load. These forces can swing the load and increase both the load and load radius sufficiently to cause an overload condition.

Be certain the boom tip is centered directly over the load before lifting. Dragging the load with the hoist or boom from any position is prohibited.

LOAD HANDLING SAFETY

Never leave equipment with load suspended. Lower load to the ground and stop engine before leaving control station.

Avoid load swinging. Such practice can create unstable conditions and place undue stress on the boom.

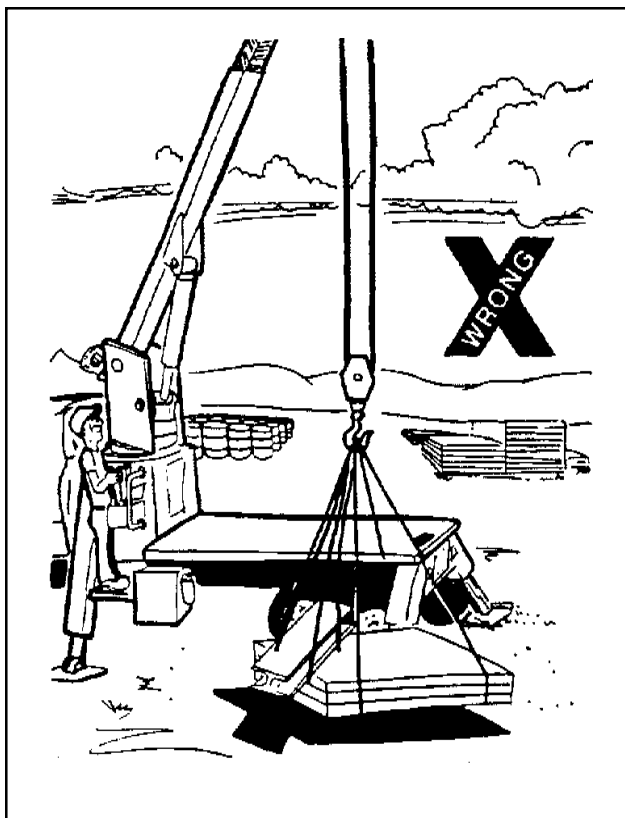

Figure 1-5. Never Lift Two Separate Loads at the Same Time

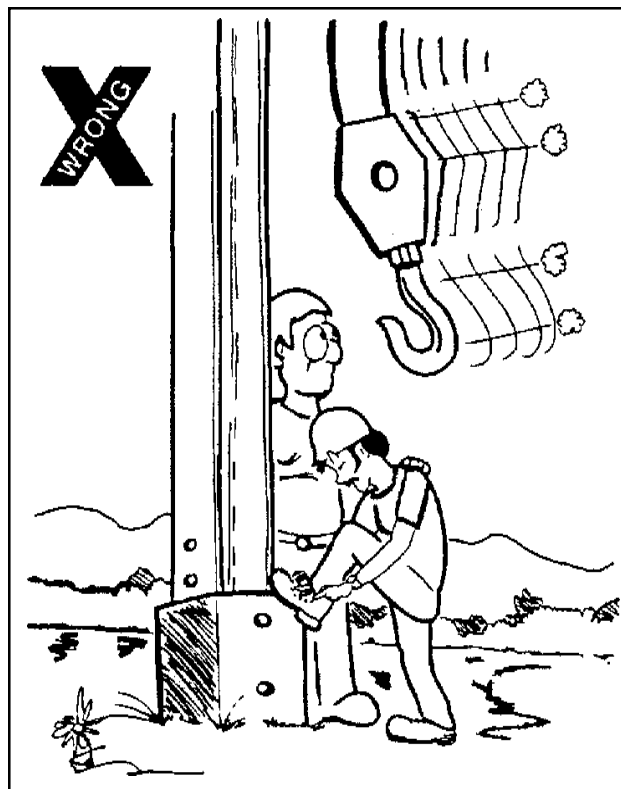

Figure 1-6. Keep Operating Area Clear of Personnel

OUTRIGGER/STABILIZER SAFETY

Ensure machine is level and stabilized and that the brakes are properly set prior to operating the boom (use the bubble level on the operator's control station).

Check clearance on both sides before outriggers are extended and set. Make sure personnel are clear of outriggers.

Set outrigger pads only on solid footing.

Blocking or cribbing should be used underneath outriggers to assist in machine leveling when crane is up on non-level ground or when supporting surface is soft or unstable.

Never set an A-frame outrigger on a curb. The load may cause the unit to tip due to the shortened fulcrum point of the outrigger.

Do not attempt to "walk" machine sideways on outriggers as serious damage will occur to outrigger components.

Outriggers must be properly extended, firmly set and crane level before operation is permissible.

OPERATING SAFETY

Allow only authorized and qualified personnel to operate the equipment. Such personnel must be trained and be familiar with the manufacturer's instructions and manuals, all worksite and local rules pertaining to crane operation, and must have demonstrated and understanding of proper machine operation.

Check clearances around turntable, boom and load during swinging, raising, lowering and telescoping operations.

Never use boom for any other purposes than hoisting and positioning intended loads.

Never smoke or allow an open flame when refueling the truck fuel tank. Stop the truck engine during refueling.

At all times, ensure that hands, feet, hair and loose clothing are kept away from moving sheaves, drums and cables.

Under no circumstances should any part of the equipment be modified in any way without the express permission of the manufacturer. Such modification will not only

void any warranty consideration, but could seriously effect safe operation of the crane.

Never allow personnel to ride the load, sling or hook.

Know all standard hand signals. Do not operate the equipment if warning or caution placards are missing or illegible.

Machine will upset if boom is extended over side without outriggers set.

No "on rubber" crane operation is permitted, including swinging, elevating and telescoping boom.

Always remove hookblock or headache ball, along with optional boom extension, if necessary, when personnel platform is installed.

Operating area for front-mounted pedestal is restricted to 180° over rear of unit, unless equipped with front bumper stabilizer, which permits 360° operation.

OPERATING AREA SAFETY

Ensure that areas around and under suspended loads are kept clear of personnel and equipment. Keep eyes and mind on the operation at hand.

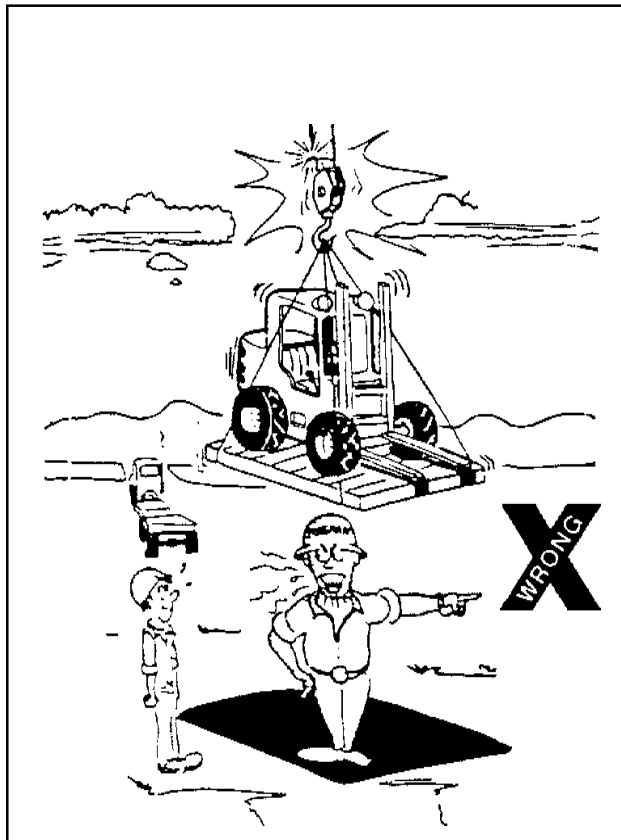

Figure 1-7. Do Not Position Load or Boom Over Personnel

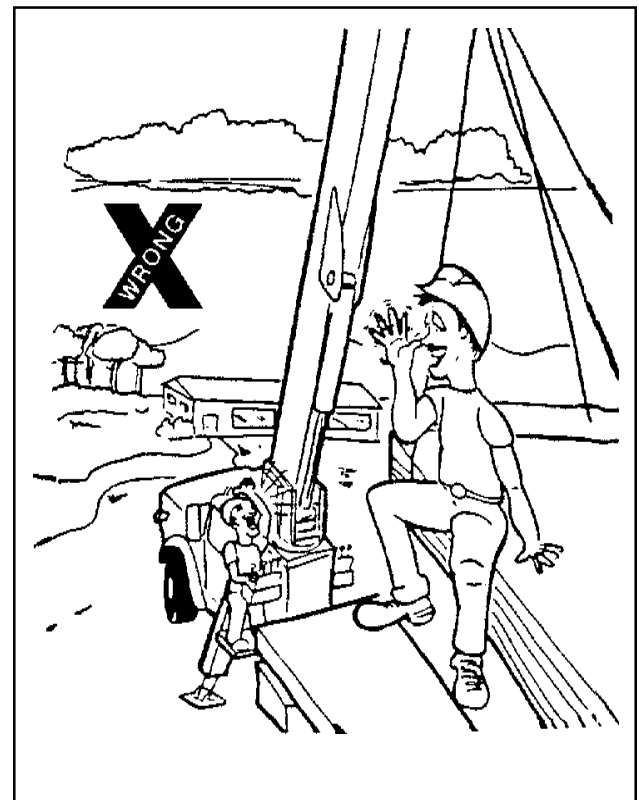

Figure 1-8. Allow No One to Ride the Load

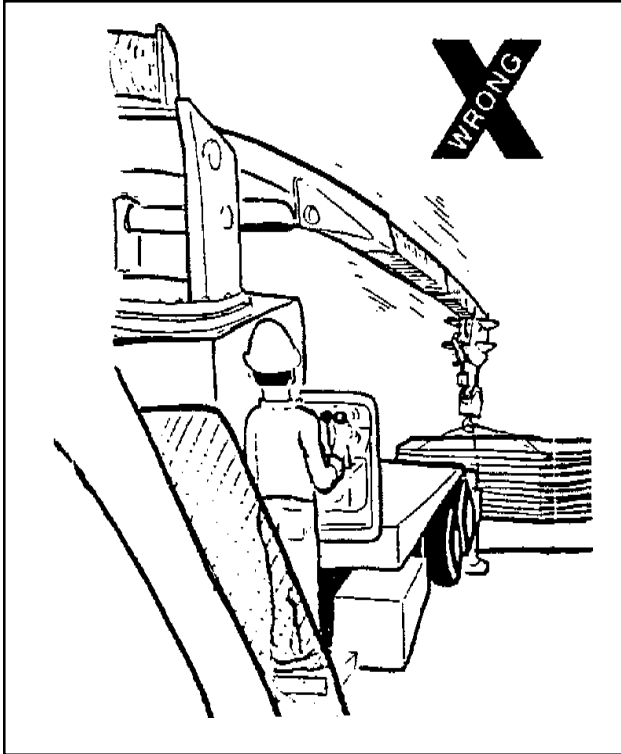

Figure 1-9. Never Guess at the Load Weight

Never position boom over ground personnel even if no load is attached to or suspended from boom.

Keep deck, foot holds, hand holds, foot wear, and all control surfaces free of oil, mud, grease, slippery substances and debris.

WIRE ROPE SAFETY

Ensure that cable is properly routed around sheaves and drums before operation and after any slack has been present in the cable. Check for overlapping cable on hoist drum.

Do not operate the crane with worn, damaged or frayed cables or improperly installed clamps.

Avoid handling cables with bare hands.

Never wrap a hoist line around the load in place of a sling or chain. Never use discarded wire rope to make slings.

DRIVING SAFETY

Never drive machine with outriggers extended.

Ensure outriggers are completely retracted prior to moving.

If equipped with the optional front or rear stabilizer, cylinder must be fully retracted, tilted back and pinned prior to moving.

Always post a lookout when backing up to verify that the rearward area is clear.

Ensure that turntable, boom and hookblock are in the stowed position when traveling.

Ensure that jib stowage pins and extendable jib pin are in place and secured with hair pins prior to moving machine.

Be aware of clearances when traveling.

Check tire condition weekly and maintain correct pressure at all times on all tires.







Avoid overhanging loads when traveling. Always ensure load is properly secured to deck. Ensure load is properly secured to deck. Ensure tie-downs, chains and slings are strong enough to restrain load.

When hauling a load, always ensure load is within rated truck capacity. Over-the-road weight limits may vary from state to state. Therefore owner/operator must comply with any local, state or federal regulations covering the use of this equipment on public streets or highways.

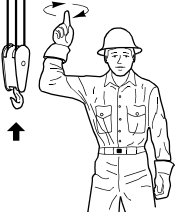
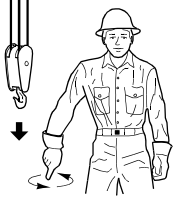
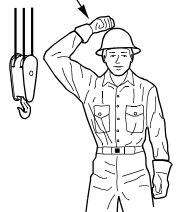
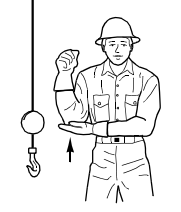
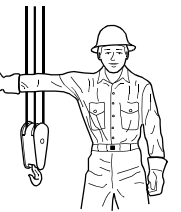
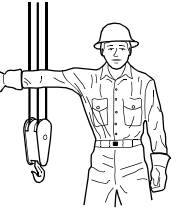

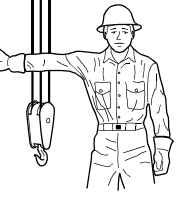
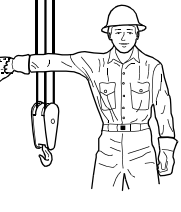
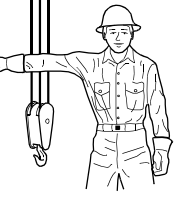
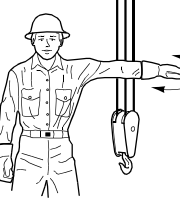
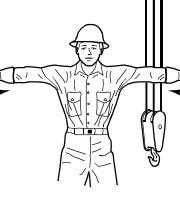
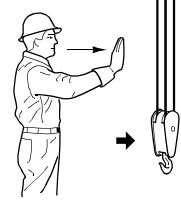
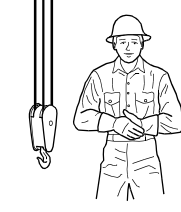
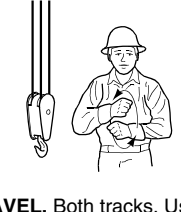
Figure 1-10. Avoid Overhanging Loads

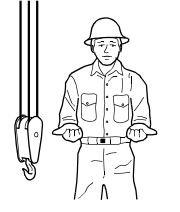
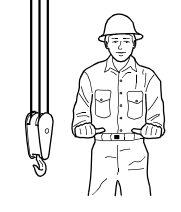
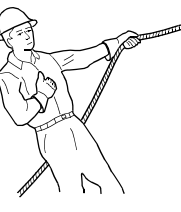
STANDARD HAND SIGNALS FOR CONTROLLING CRANE OPERATIONS
 Complies with ASME/ANSI B30.5 – 1993

 <p>HOIST. With forearm vertical, forefinger pointing up, move hand in small horizontal circle.</p>	 <p>LOWER. With arm extended downward, forefinger pointing down, move hand in small horizontal circles.</p>	 <p>USE MAIN HOIST. Tap fist on head; then use regular signals.</p>	 <p>USE WHIPLINE. (Auxiliary Hoist.) Tap elbow with one hand; then use regular signals.</p>	 <p>RAISE BOOM. Arm extended, finger closed, thumb pointing upward.</p>
 <p>LOWER BOOM. Arm extended, fingers closed, thumb pointing downward.</p>	 <p>MOVE SLOWLY. Use one hand to give any motion signal and place other hand motionless in front of hand giving the motion signal. (Hoist slowly shown as an example.)</p>	 <p>RAISE BOOM & LOWER LOAD. With arm extended, thumb pointed up, flex fingers in and out as long as load movement is desired.</p>	 <p>LOWER BOOM & RAISE LOAD. With arm extended, thumb pointed down, flex fingers in and out as long as load movement is desired.</p>	 <p>SWING. Arm extended, point with finger in direction of swing of boom.</p>
 <p>STOP. Arm extended, palm down, move arm back and forth horizontally.</p>	 <p>EMERGENCY STOP. Both arms extended, palms down, move arms back and forth horizontally.</p>	 <p>TRAVEL. Arm extended forward, hand open and slightly raised, make pushing motion in direction of travel.</p>	 <p>DOG EVERYTHING. Clasp hand in front of body.</p>	 <p>TRAVEL. Both tracks. Use both fists in front of body, making a circular motion about each other, indicating direction of travel; forward or backward.</p>
 <p>TRAVEL. (One Track.) Lock the track on side indicated by raised fist. Travel opposite track in direction indicated by circular motion of other fist, rotated vertically in front of body.</p>	 <p>EXTEND BOOM. (Telescoping Booms) Both fists in front of body with thumbs pointing outward.</p>	 <p>RETRACT BOOM. (Telescoping Boom) Both fists in front of body with thumbs pointing toward each other.</p>	 <p>EXTEND BOOM. (Telescoping Boom) One Hand Signal. One fist in front of chest with thumb tapping chest.</p>	 <p>RETRACT BOOM. (Telescoping Boom) One Hand Signal. One fist in front of chest, thumb pointing outward and heel of fist tapping chest.</p>

da0109

4000151-001 (B)

Figure 1-11. Hand Signals

MACHINE INSPECTION REQUIREMENTS

It should be noted that Occupational Safety and Health Administration (OSHA) regulations state that all cranes of the type covered by this manual be inspected and maintained on a regular, daily basis in accordance with recommendations made by the equipment manufacturer. In addition, a thorough annual inspection must be performed and a complete record of the inspection dates and results be maintained. These legal requirements are from OSHA Regulation 29CFR Parts 1910.180 1926.550. They are also specified in American National Standards Institute (ANSI) standard B30.5-1994-Safety Code For Cranes, Derricks, Hoists, Jacks and Slings.

USTC recommends that inspection procedures outlined in this and other manuals pertaining to this unit be followed and that a written record be maintained and available for review by Department of Labor personnel should the need arise. Further requirements are dependent upon state and local ordinances which govern the particular area in which the equipment operates.

USTC has inspected and tested the machine for stability and correct operation, if mounted at the factory. If mounted by an authorized distributor, the crane has been inspected and tested by the distributor. If any authorized changes are made to the machine, it is the responsibility of the owner to conduct stability or other tests to verify the correct installation of additional functions.

⚠ WARNING: DO NOT MODIFY IN ANY WAY OR USE UNAUTHORIZED PARTS ON THE MACHINE WITHOUT THE EXPRESS WRITTEN CONSENT OF USTC, INC.

PREPARATION FOR USE

Before a new unit is initially placed into service and periodically thereafter, it should be thoroughly inspected for signs of damage, such as oil, fuel and hydraulic leaks, and correct cable routing. Security of attaching hardware should also be checked.

All preparation necessary to place the unit in a state of operational readiness is the responsibility of management personnel. Most requirements are relatively simple, involving common sense coupled with a series of visual inspection guidelines. Refer to the New Machine Inspection/First Delivery/End of Warranty form shipped with each machine.

⚠ WARNING: SINCE THE MANUFACTURER HAS NO DIRECT CONTROL OVER MACHINE APPLICATION AND OPERATION, CONFORMANCE WITH GOOD SAFETY PRACTICE IN THIS AREA IS THE RESPONSIBILITY OF THE USER AND HIS OPERATING PERSONNEL.

LUBRICATION

The lubrication points to be covered periodically are illustrated and defined in Figure 2-1 and Table 2-1.

Intervals are shown in hours and assume full-time operation. In general operating hours should be converted to time as follows:

10 hours	Daily
50 hours	Weekly
100 hours	Every two weeks
250 hours	Monthly
1000 hours	Every six months
2000 hours	Annual

If usage is not constant and an equivalent amount of time passes, service the machine before the listed amount of operating hours has accumulated.

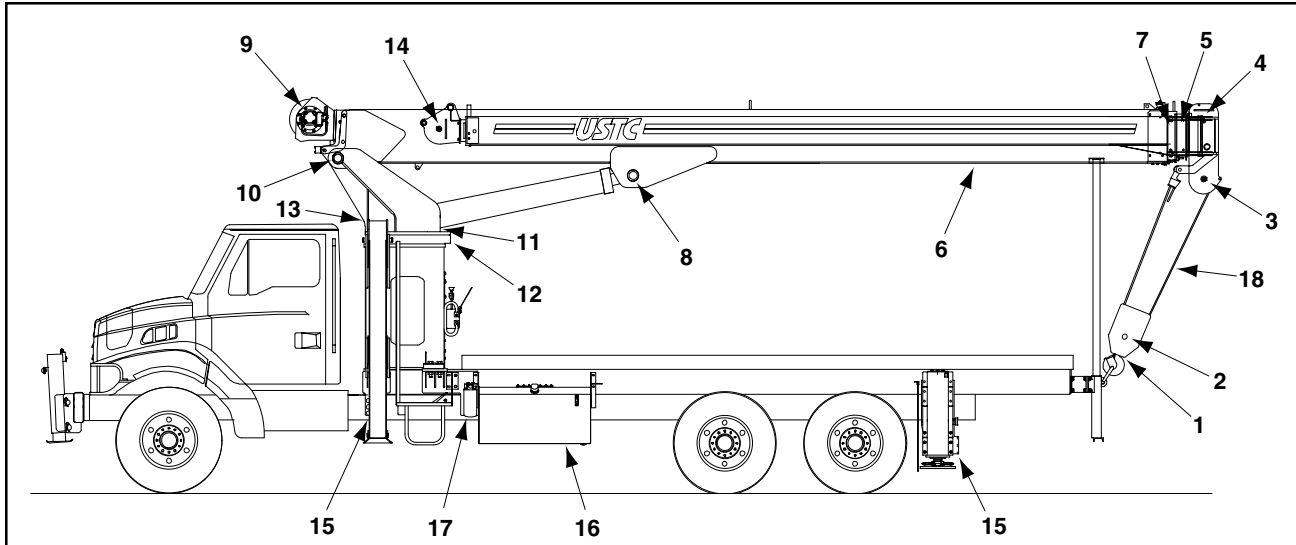

Figure 2-1. Lubrication Points

TABLE 2-1. Lubrication Points and Intervals

INDEX NO.	DESCRIPTION	LUBRICANT	HOURS	FITTINGS	NOTES
1	Hook Bearing	MPG	50	1	
2	Hookblock Sheave	MPG	50	1	
3	Lower Boom Nose Sheaves	MPG	50	1	
4	Upper Boom Nose Sheave	MPG	50	1	
5	Fly Extend Cable Sheave	MPG	50	1	Align holes in mid and fly.
6	Boom Assembly	MPG	500		Extend boom. Brush on wear pad travel area.
7	Fly Cable Retract Sheave	MPG	50	2	Align access hole in base boom.
8	Boom Pivot Bushing	MPG	50	2	
9	Hoist Oil Level – Check w/ boom at 0° by using the large oil level plug located in center of support.	API GL-2/3	100/1000		Change oil after first 100 hours and every 1000 hrs. thereafter.
10	Upper Lift Cylinder Pin	MPG	50	1	
11	Lower Lift Cylinder Pin	MPG	50	1	
12	Swing Bearing Pinion and Swing Bearing Teeth	MPG	50 500	2	Apply MPG, rotate turntable 90° and return, reapply MPG and rotate 90° in opposite direction.
13	Swing Gear Box	EPGL	250/1000		Change oil after first 250 hrs. and every 1000 hrs. thereafter. Oil level to be 1 1/2" from top of hub.
14	Jib Sheave (Optional)	MPG	50		
15	Outrigger/Stabilizer Wear Pads	MPG	500		Extend beam. Brush on wear pad travel area.
16	Hydraulic Oil Reservoir	HO	10/2000		Check level every 10 hrs. Change oil annually.
17	Hydraulic Oil Filter		50/250		Change filters after first 50 hrs. and 250 hours thereafter.
18	Hoist Wire Rope	PL	100		Brush on.
NS	Platform Pivot (Optional)	MPG	200	2	
NS	Platform Door Hinges	MPG	200	2	
NS	LMI Dynamometer (If Equipped)	MPG	50	2	

NS Not Shown

Lubricants MPG Multi-Purpose Grease. Requires minimum dripping point of 350°.
 EPGL Extreme Pressure Gear Lubricant meeting API GL-5 or MIL-L-2105.
 API GL-2/3 Hoist Lubricant
 HO Hydraulic Oil meeting API GL-3. SAE 10W-20, viscosity 152 recommended.

OPERATOR'S DAILY CHECKLIST

This paragraph provides a listing of those inspection procedures which must be performed before placing the unit in operation each day. Careful attention should be paid during actual operation of the unit to observe any condition which might occur between regular inspections that could possibly be a safety hazard.

Proper inspection of the crane is also of extreme importance and reference must be made to the appropriate vehicle components.

⚠ WARNING: DO NOT OPERATE EQUIPMENT UNTIL NECESSARY CORRECTIVE ACTIONS HAVE BEEN TAKEN TO REMEDY ANY NOTED MALFUNCTIONS.

1. Visually inspect machine for loose or missing parts, foreign objects, hydraulic leaks from lines or components and structural damage.
2. Ensure that tires are inflated to the proper pressure. Refer to tire sidewall or contact tire manufacturer for proper tire inflation pressure.
3. With all systems shut down and machine is stowed or travel position, check oil level in hydraulic fluid reservoir. If necessary, fill to FULL mark on tank sight gauge.

Note: On new or recently overhauled machines or after changing hydraulic oil, operate all systems a minimum of two complete cycles and recheck oil in reservoir.

⚠ WARNING: NEVER HANDLE CABLES OR WIRE ROPE WITH BARE HANDS. BROKEN OR FRAYED STRANDS CAN CAUSE SEVER CUTS. ALWAYS WEAR PROTECTIVE GLOVES IF IT IS NECESSARY TO HANDLE CABLE OR WIRE ROPE.

4. Inspect cable for defects as follows:
 - a. Corrosion
 - b. More than one broken wire in any one strand.
 - c. More than one broken wire near an attach fitting.
 - d. Excessive wear or broken wires in cable sections under sheaves where cable travel is limited.
 - e. Evidence of noticeable reduction in original cable diameter after allowance for normal stretch and diameter reductions of newly rigged cable.
 - f. Excessive abrasion, scrubbing and peeling of outer wires, pitting, deformation, kinking, bird caging or other damage resulting in physical changes to the cable structure.
 - g. Cracked, bent, worn or improperly installed wedge socket.
5. Inspect hook for security of attachment, proper swivel lubrication and for nicks, cracks, gouges, deformation or evidence of any other damage. Check for proper operation of hook safety latch.
6. Inspect hookblock for security of attachments, proper lubrication and for nicks, cracks, gouges, deformation or evidence of any other damage.
7. Check wedge socket for proper size and proper cable installation. Refer to Section 3.
8. Ensure that all components requiring lubrication are serviced as necessary. Refer to Service and Lubrication Chart.
9. Ensure that all control placards, located adjacent to the corresponding control device and all safety, warning and instruction placards are securely attached and legible.
10. Inspect steps, hand holds, deck, operator control station and controls to ensure they are free of oil, grease, mud, water, debris and foreign objects (tools, rags, etc.) Check entire machine for debris which may interfere with operation.
11. Using all applicable safety precautions, start engine and with PTO engaged, check indicator on top of hydraulic filter assembly mounted adjacent to oil tank for condition of element. Change element as indicated.

12. With unit operating and before starting actual jobsite operations, inspect the following:
- Smooth and proper operation of all crane and outrigger functions. Check that Outrigger-In-Motion Alarm system is working properly.
 - Check that boom and jib cable sheaves rotate freely and ensure that they are in good condition.
 - Inspect all control levers, switches and accelerator pedals and cables for proper installation and operation.
 - Check operation of STOP, START and HORN switches.
 - Check for proper operation of all lights and reflectors.
 - Check anti-two-block device for proper operation. The load handling device must stop when it contacts the anti-two-block counterweight while hoisting up or telescoping out.
 - If equipped with Overload Audio/Visual Warning or Overload Cut-off, test the system by activating the toggle switch labeled “Capacity Alert Test Switch” located on the console. When the test switch is activated, the warning light must flash, the warning horn sound and the following crane controls must be disabled: Hoist Up, Telescope Out, Boom Up, and Boom Down.

Next, lift and hold the “Override Switch for Lift Up Only” and attempt to lift the boom from its current position. If the boom elevates, the system is working properly.

⚠ WARNING DAMAGE TO EQUIPMENT OR PERSONNEL MAY OCCUR IF THE FOLLOWING IS NOT ADHERED TO.

Note: The overload warning, overload cut-off and the LMI systems are an operational aid only and shall not be a substitute for good operator judgement, experience, and use of safe crane operating procedures. The responsibility for the safe crane operation shall remain with the crane operator who shall ensure that all warnings and instructions supplied are fully understood and observed.

- If equipped with an LMI, refer to the manufacturer's operation manual for daily and pre-operational checks to be performed. The manual is supplied with the crane and should be kept with the crane at all times.

PERIODIC INSPECTION

Note: This machine requires annual inspections by an authorized distributor. A decal, located on the pedestal provides a place to record (stamp) inspection dates. Notify distributor if inspection is overdue.

The crane must be thoroughly inspected periodically so as to detect in a timely manner the possibility of damaged or improperly installed parts. Frequency of inspection will to a large extent depend upon crane activity and severity of service but under no circumstances should the interval for the below listed inspections exceed one month. These inspections should also include those listed in the Daily Inspection Checklist.

The appropriate truck manual should be consulted for those inspection procedures which pertain to the carrier and the recommendations of the manufacturer must be strictly adhered to.

- Inspect crane for any signs of deformation, damage and attaching hardware for security and missing items. Particular attention should be paid to areas of high potential stress, such as crane/truck frame attach points and outriggers.
- Inspect outrigger assemblies for evidence of leakage and security of attachment. Check pressure lines for evidence of abnormal chafing.
- Inspect PTO assemblies for security, wear and damage.
- Inspect main hydraulic pumps and lines for damage, evidence of leakage and security of attachment.
- Check hydraulic fluid reservoir and lines for damage, evidence of leakage and security of attachment. Check filter indicators for element condition. Clean or replace elements as necessary.
- Check control levers at both operator control stations for visible damage, loose or missing parts and proper lubrication. Assure that levers function properly.
- Check control switches at both operator control stations for visible damage, loose or missing parts, security of attachment, electrical connections for corrosion and tightness and wiring for proper routing. Assure that switches function properly.
- Check instruments on truck instrument panel for damage and security of installation. Check PTO cable and indicator light for damage and security of attachment.

9. Inspect load capacity charts, hook height chart, operating radii chart and corresponding lifting notes, decals and instruction chart for legibility and security.

⚠ WARNING: DO NOT USE AN OPEN FLAME TO PROVIDE ILLUMINATION FOR BATTERY CHECKS. GASES GIVEN OFF BY THE BATTERY ARE EXPLOSIVE AND POTENTIALLY DANGEROUS TO PERSONNEL.

10. Check batteries for damage, loose or missing cell caps, security and condition of cable connections, hold-down brackets and electrolyte for proper level. Add only clean distilled water as necessary.
11. Check integral swing gear, bearing, bolts and nuts for damage, uneven wear patterns, correct lubrication and proper meshing of pinion gear.
12. Inspect turntable and pedestal for obvious damage such as cracked welds, loose or missing hardware.
13. Check lift cylinder and hydraulic lines for damage, evidence of leakage and security of attachment.
14. Check boom pivot bushing for evidence of correct lubrication and shaft retainers for damage and security. Lubricate as necessary.
15. Check hoist for damage, evidence of leakage and security of attachment. Check for correct lay of cable on drum. Check hydraulic lines to hoist for damage, evidence of leakage and security of attachment. Check cable attachment to hoist drum.
16. Check boom angle indicator components for damage, legibility, security of attachment and proper operation.
17. Check boom structure for damage, missing or loose parts and hardware and security of attachment.
18. Check visible wear pads for damage, excessive wear and security of attachment.
19. Check jib extension for structural damage, security of attachment and evidence of sheave lubrication.
20. Check boom nose sheaves for damage, security of attachment, evidence of lubrication and correct cable seating in sheave grooves.

21. Check all cable guards and guides for damage and security of attachment.
22. Check jib stowage pins and extendible jib pin for security of attachment.
23. Check hookblock sheave for damage, correct routing of cable around sheave grooves and evidence of proper lubrication at sheaves and hook swivel.
24. Check hook for damage, security of attachment and correct hook latch operation.
25. Check lift cylinder boom attach pivot points for evidence of lubrication.
26. Check boom rest for damage and security of attachment.
27. Check that all components requiring lubrication are serviced as necessary.
28. Check that no unauthorized modifications have been made to machine.
29. Check platform (if equipped) for damage, security of attachment, loose or missing hardware. Check that the brake holds securely.

TRANSPORTING

General

Certain precautions must be taken to ensure safety of personnel and to avoid damage to equipment when moving the crane between jobsites. The safety precautions provided here are not intended to replace or take precedence over federal, state or local laws which govern the use of truck mounted cranes. In addition, insurance regulations should be recognized when applicable and the vehicle manufacturer's recommendations for driving should be followed.

Transport

1. Never travel with a load on the hook.
2. Ensure that the boom is retracted and properly stowed in the boom rest.
3. Always secure the hook or hookblock to the pintle at the rear or front of the unit.

4. Remove counterweight from anti-two-block switch.
5. Ensure that outriggers are fully retracted and that pad pins and snap rings are secure.
6. If applicable, ensure that the jib assembly is securely stowed.
7. Check that the oil tank filter is properly installed.
8. Disengage the PTO.
9. Secure or remove all loose items.
10. If applicable, remove and properly stow the personnel platform.
11. Ensure that tires are inflated to the proper pressures.
12. Allow no one to ride on the equipment during transportation and do not exceed truck cab seating capacities.
13. If necessary, appoint a person to provide the proper signals when maneuvering the unit in close quarters or when visibility is limited.

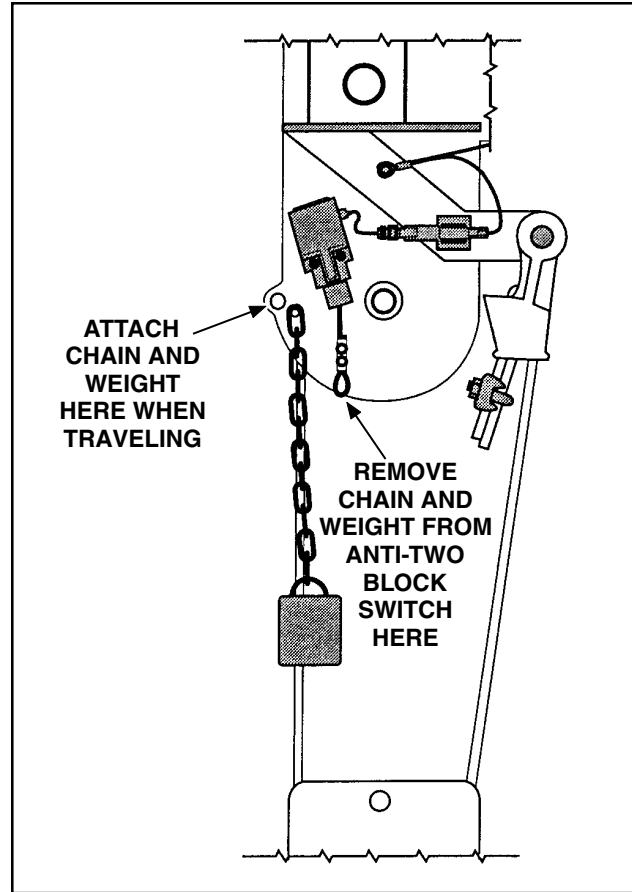

Figure 2-2. Anti-Two Block Switch

AUTHORIZED OPERATING PERSONNEL

⚠ WARNING: SINCE THE MANUFACTURER HAS NO DIRECT CONTROL OVER MACHINE APPLICATION AND OPERATION, CONFORMANCE WITH GOOD SAFETY PRACTICE IN THIS AREA IS THE RESPONSIBILITY OF THE USER AND HIS OPERATING PERSONNEL.

The crane is designed as a versatile crane, mounted on a standard commercial heavy-duty truck, capable of moving quickly between job sites. It is to be operated only by qualified personnel who have demonstrated an understanding of proper use of the equipment. It is essential that operating personnel receive a thorough training and familiarization program before being allowed to operate under normal working conditions.

The initial phase of the training program should include a complete study of this manual coupled with actual operation of all equipment functions under simulated operating conditions. These simulated conditions should include, where possible, any emergency procedures which may be encountered during actual use.

The operator must be familiar with the capacities and limitations of this equipment. For this reason, the weight of the load and the load radius must be known at all times during operation.

⚠ WARNING: DO NOT OPERATE EQUIPMENT UNTIL NECESSARY CORRECTIVE ACTIONS HAVE BEEN TAKEN TO REMEDY ANY NOTED MALFUNCTIONS.

OPERATING CHARACTERISTICS AND LIMITATIONS

GENERAL

A thorough knowledge of the operating characteristics and limitations of the equipment is the first requirement for an operator, regardless of prior experience with similar types of equipment.

Note: Reference to right and left hand controls is determined from crane operator control stations with operator facing controls.

CONTROL PLACARDS

Placards (decals) are installed at locations on equipment to both instruct personnel on equipment use and to alert personnel of potential hazards. Such placards must be heeded by the operating personnel at all times.

⚠ WARNING: NEVER OPERATE MACHINE IF PLACARDS ARE MISSING OR ILLEGIBLE.

CAPACITIES AND STABILIZATION

All load capacity ratings for the machine are based on the following criteria:

- Equipment is positioned on a firm, level and smooth surface, and the outriggers are fully extended, with the tires off the ground.
- Truck brakes are properly engaged.
- Visibility is good.
- Equipment is in good condition and properly equipped.
- There are no side loads and there is no danger of load outswing.
- The load is within the rated design capacity for lifting on properly extended outriggers as reflected on the Load Capacity Chart.
- The boom is fully retracted against stops to achieve maximum rated lift capacity as indicated on Load Capacity Chart.

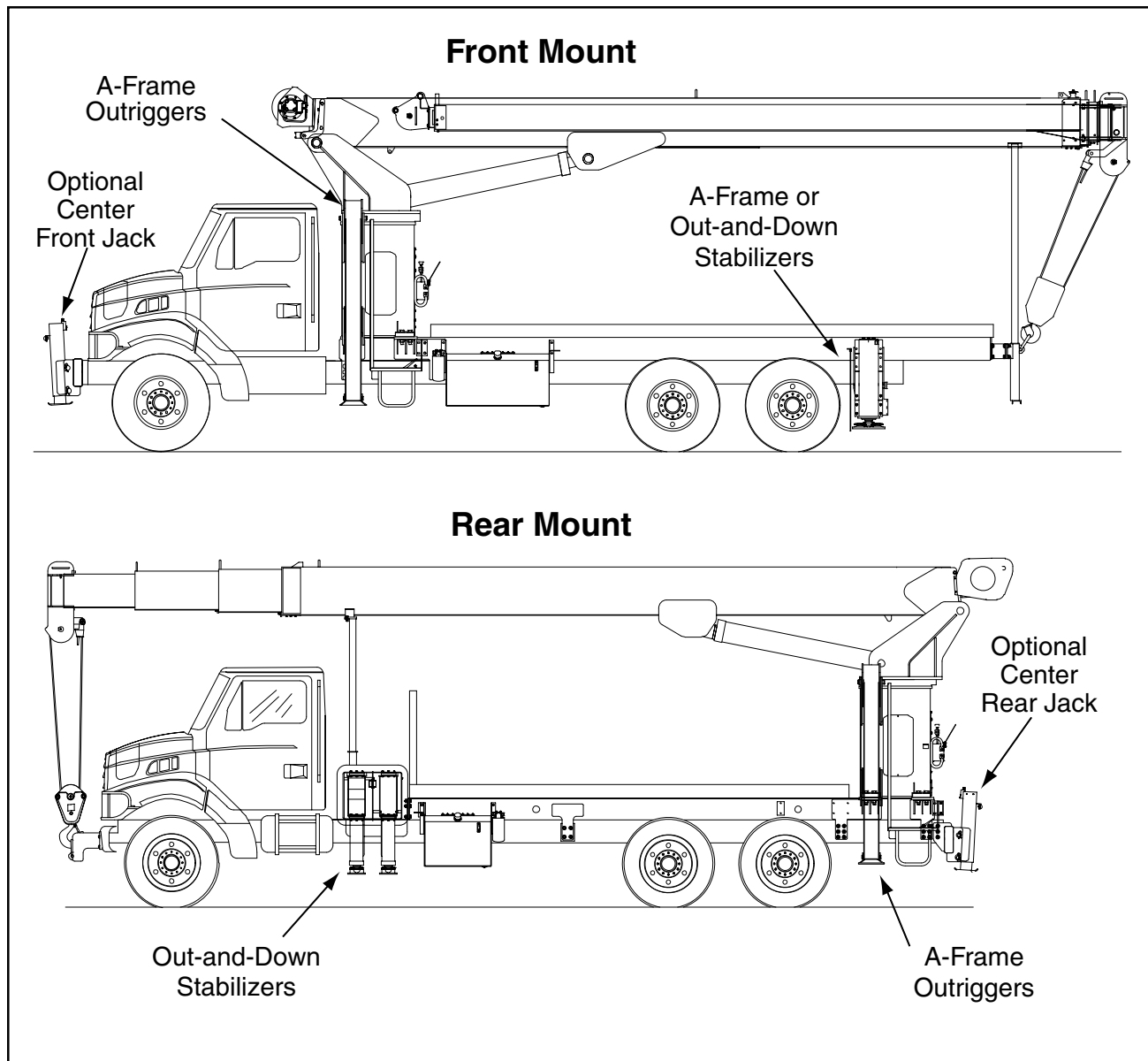

Figure 3-1. Outrigger and Stabilizer Locations

CONTROLS AND INDICATORS

Duplicate crane controls for normal operation are located on each side of the machine within easy reach of the operator. All engine controls and gauges are contained in the truck cab with the exception of the foot throttle and engine stop switch. The engine speed and start and stop can be controlled from each of the operator’s stations.

Note: Due to the location of the engine controls and gauges, the operator must start the engine, engage the PTO and monitor all gauges from the truck cab before proceeding with any crane operation. An optional engine

start (IGNITION) switch at operator control station is available. Refer to applicable vehicle manual for operating instructions. Gauges and indicators should include fuel, air pressure, oil pressure, water temperature, ammeter and tachometer. These gauges must be monitored at engine start and periodically during crane operation.

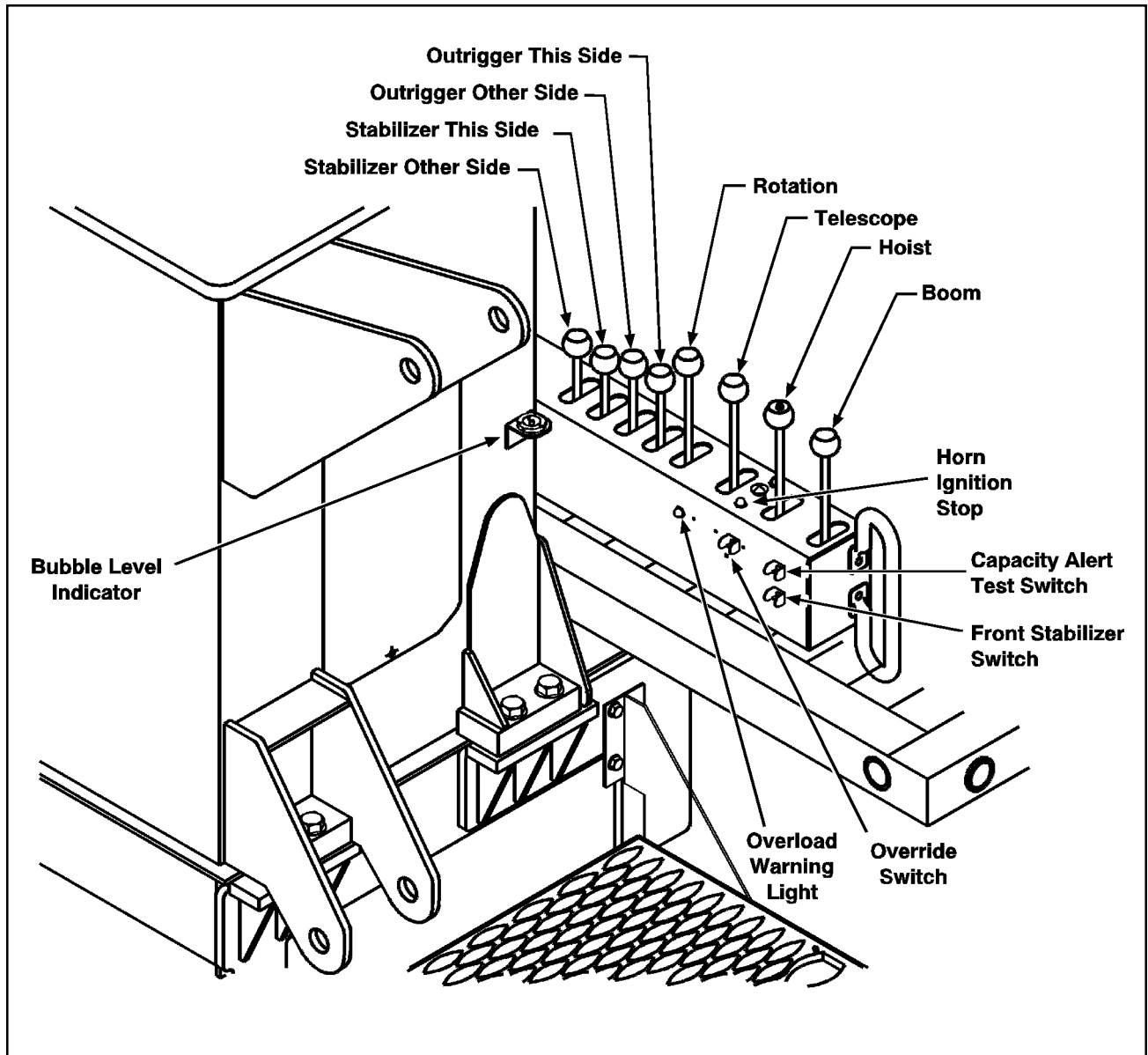

Figure 3-2. Operator's Control Station

OUTRIGGER CONTROLS

General

Stabilization of the machine is achieved by use of A-frame outriggers mounted on the forward side of the crane pedestal and A-frame or out-and-down stabilizers mounted just rear of the rear axle. On machines equipped with a rear mounted pedestal, the A-frame outriggers are mounted on the forward side of the crane pedestal and stabilizers are located just aft of the truck cab.

⚠ WARNING: BE SURE AREA IS CLEAR WHEN EXTENDING OR RETRACTING OUTRIGGERS.

⚠ WARNING: OUTRIGGER BEAMS MUST BE FULLY EXTENDED BEFORE JACKS ARE OPERATED. ALWAYS RAISE JACKS BEFORE RETRACTING BEAMS.

Outrigger and Stabilizers Types

A-Frame Outriggers – The front outriggers are controlled by a mechanical arrangement through two manually operated hydraulic control valves. Two control levers located at each operator control station provide for independent control of each outrigger leg.

The levers are labeled **OUTRIGGER THIS SIDE** and **OUTRIGGER OTHER SIDE** with arrows on the knob indicating lever direction for **EXTEND** and **RETRACT**. Speed of outrigger movement is regulated by control lever position.

On machines equipped with a rear-mounted pedestal, the outriggers are located at the rear of the truck deck on the forward side of the pedestal.

A-Frame Stabilizers – The rear-mounted A-frame stabilizers are mounted under the deck. They are controlled by a mechanical arrangement through two manually operated hydraulic control valves. Two control levers located at each operator control station provide for independent control of each stabilizer leg. The levers are labeled **STABILIZER THIS SIDE** and **STABILIZER OTHER SIDE** with arrows on the knob indicating lever direction for **EXTEND** and **RETRACT**. Speed of stabilizer movement is regulated by control lever position.

Out-and-Down Stabilizers – The out-and-down stabilizers are hydraulically operated and mechanically and electrically controlled. Two manually operated hydraulic control valves control the direction of either the beam or jack cylinders. An electrically controlled hydraulic valve stack switches flow between the beam and jack cylin-

ders. The hydraulic valves are controlled by two control levers located at each operator control station.

The levers are labeled **STABILIZER THIS SIDE**, **STABILIZER OTHER SIDE** and **STABILIZER BEAM** with arrows on the knob indicating lever direction for extend or retract. The beam cylinders are extended by depressing the button on the left stabilizer control lever and moving the lever in the direction indicated by the arrows on the control knob for either **OUT** or **IN**.

Front/Rear Center Jack Stabilizer – The center jack stabilizer is hydraulically operated and controlled by simultaneous operation of a manually operated hydraulic valve and an electrically operated hydraulic stack valve. Operation requires that the Front Stabilizer switch and the Street Side Stabilizer lever be operated simultaneously.

 **CAUTION: OPERATING THE REAR STABILIZER CONTROL LEVER WITHOUT FIRST ACTIVATING THE TOGGLE SWITCH WILL OPERATE THE REAR STABILIZER AND POSSIBLY BRING THE CRANE OUT OF LEVEL. IF THIS OCCURS, BE SURE TO LEVEL THE CRANE BEFORE THE BOOM IS RAISED FROM THE BOOM REST.**

Outrigger/Stabilizer-In-Motion Alarm

This audible warning device alerts personnel when outriggers or stabilizers are in motion. The alarm will activate during either extension or retraction. This system also includes flashing lights located adjacent to each outrigger. The flashing lights will illuminate to indicate which outrigger or stabilizer is in motion.

BOOM CONTROLS

Control of all crane functions is achieved by the use of control levers located at the operator's control console on each side of the pedestal. All controls are proportional so the farther the lever is moved, the greater the speed of the function.

The position of the crane controls are duplicated and in the same order on each side.

Note: The outrigger and stabilizer controls are always on the inside of the crane controls.

The order of the levers from left to right is rotation, telescope, hoist and lift. Each function is proportional and the speed will increase according to the displacement of the control lever.

Rotation

Swings the boom in either direction. Move lever away to rotate boom counterclockwise (left-hand). Move lever closer to rotate boom clockwise (right-hand).

Telescope

Extends and retracts each boom section proportionately. Move lever away to extend boom sections. Move lever closer to retract boom.

Hoist

Raises and lowers the lifting device by extending or retracting the cable.

Move lever away to lower lifting device (lengthen cable). Move lever closer to raise lifting device (shorten cable).

Burst-of-Speed

A button on top of the hoist lever activates the burst-of-speed, increasing the hoist speed. Hold the button to activate burst-of-speed. Release the button to resume normal operation.

Lift

Changes elevation (angle) of boom. Move lever away to lower boom. Move lever closer to raise boom.

⚠ WARNING: TELESCOPING THE BOOM CHANGES THE RADIUS OF LOAD. MAKE SURE LOAD IS WITHIN OPERATING RANGE BY REFERENCING LOAD CAPACITY CHART.

⚠ WARNING: CHANGING THE BOOM ELEVATION (ANGLE) CHANGES THE RADIUS OF THE LOAD. MAKE SURE LOAD IS WITHIN OPERATING RANGE OF CRANE BY REFERENCING THE LOAD CAPACITY CHART.

INDICATORS AND ENGINE CONTROLS

Engine Stop Switch

An ENGINE STOP switch is mounted on the top panel between the hoist and telescope levers at each operator's station. The switch is a push/pull switch. To stop the engine, push the switch and hold until the engine stops.

⚠ CAUTION: THE ENGINE MAY CONTINUE TO OPERATE IF THE SWITCH IS PUSHED AND RELEASED TOO QUICKLY.

Ignition Switch

An ignition switch is mounted on the top panel between the hoist and telescope levers at each operator's station. To start the engine, push and hold switch until the engine starts.

Horn Switch

A push-button horn switch is located on the top panel between the hoist and telescope levers at each operator's station. Use it for signalling others of the intention to operate the crane.

Boom Angle Indicator

A pendulum boom angle indicator is mounted on each side of the base boom and is visible from each operator station. The indicator measures the full range of boom movement in 10° increments.

Crane Level Indicator

Two circular bubble level indicators are located on each side of the pedestal. The indicators allow the operator to level the crane using the outriggers and stabilizers. The bubble will be in the center of the indicator when the crane is level.

Throttle Control

A foot throttle is mounted on the floor of each operator's control station. The pedal controls engine speed throughout the speed range of the engine (low idle to high idle).

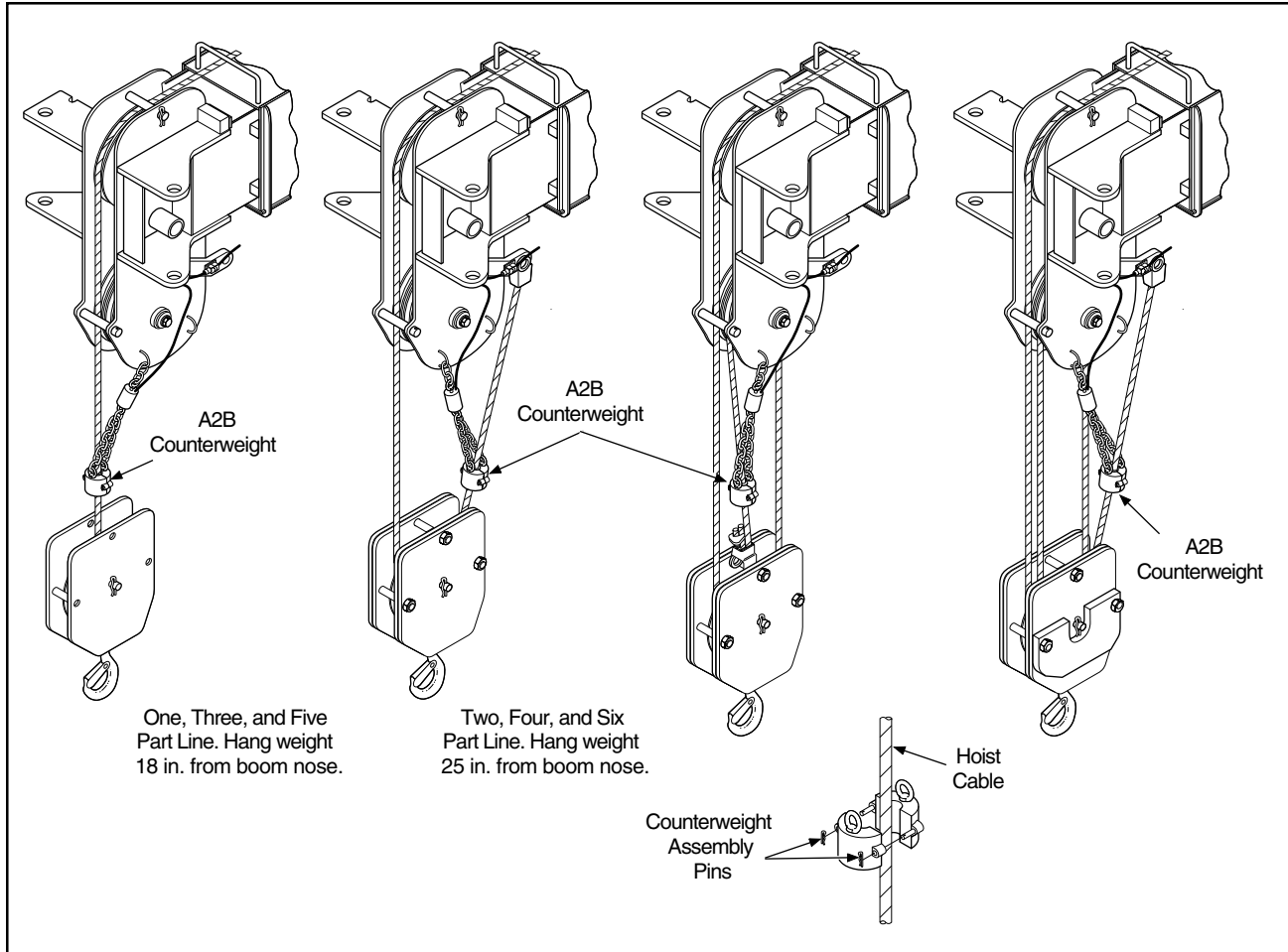

Figure 3-3. Anti-Two-Block Switch Installation

Drum Rotation Indicator

All cranes are equipped with indicators on both sides of the hoist mounting bracket. The crane operator is provided an indication of the speed and direction of the hoist.

Anti-Two-Block Device

All cranes must be equipped with an anti-two-block device which protects the boom nose. The anti-two-block device consists of a hollow weight suspended from the boom nose by a chain. The weight hangs with the hoist cable running through the center. The weight closes a switch mounted on the boom nose.

When the lift device (headache ball or hookblock) contacts and lifts the weight, the switch circuit opens. The circuit prevents operation of the hoist up and telescope out functions. The hoist down and telescope in functions

continue to operate, allowing the lifting device and weight to be lowered, closing the switch and circuit.

IMPORTANT: Do not operate crane with a malfunctioning anti-two-block device.

Overload System

A standard overload system is used to alert the operator when the crane is over its lifting capability. The system is available as a warning system or as a warning and cut-out system.

A pressure switch senses the hydraulic pressure in the lift cylinder. When the pressure rises above a preset level, the overload system is activated.

- a. Warning System – When the hydraulic pressure in the lift cylinder reaches the preset level, a warning horn is activated and an indicator light on the console is illuminated.

b. Warning and Cut-Out System – This system operates in the same manner as the warning system with a warning horn and indicator light. In addition to these alerts, the hoist up, telescope out, boom up and boom down functions will not operate.

Note: When the boom is fully elevated (over 80°) the hydraulic system may indicate a false overload. A boom angle switch prevents the overload system from disabling the boom functions.

Load Moment Indicator System

A Load Moment Indicator (LMI) system is optional on the crane. The LMI analyzes the load radius and actual load and compares it to the load chart stored in the LMI memory.

Several brands of LMI systems are available. Refer to the documentation received with the crane for information regarding the specific type of LMI installed.

⚠ WARNING: NEVER OPERATE IN AN OVERLOAD CONDITION. TELESCOPE IN OR BOOM UP TO REDUCE THE LOAD RADIUS AND INCREASE CRANE LIFT CAPACITY.

⚠ DANGER: THE OVERLOAD WARNING, OVERLOAD CUT-OUT AND THE LMI SYSTEMS ARE AN OPERATIONAL AID ONLY AND SHALL NOT BE A SUBSTITUTE FOR GOOD OPERATOR JUDGEMENT, EXPERIENCE, AND USE OF SAFE CRANE OPERATING PROCEDURES. RESPONSIBILITY FOR SAFE CRANE OPERATION SHALL REMAIN WITH THE CRANE OPERATOR WHO SHALL ENSURE THAT ALL WARNINGS AND INSTRUCTIONS SUPPLIED ARE FULLY UNDERSTOOD AND OBSERVED.

LOAD CHART

⚠ CAUTION: DO NOT OPERATE CRANE WITHOUT READING AND BECOMING FAMILIAR WITH THE INFORMATION ON THE DECALS AND PLACARDS.

In front of each operator's control station is a pivoting placard containing the Load Chart. This Load Chart is divided into several sections which contain pertinent lifting information. The information found on the Load Chart should be completely and fully understood before operating crane.

Lift Capacity Chart

This section shows the maximum weight which can be handled by the crane at various boom lengths, boom angle and load radii. The weight of the load handling device must always be deducted from the weights shown to determine the actual lift capacity. As a load is lifted and positioned, the load radius and boom length will change. Constant reference to the Lift Capacity Chart must be maintained to stay within the parameters of the machine.

One section of the Lift Capacity Chart references jib lift capacities. If the jib is being used this section supercedes the main boom lift capacities. When stowed, the weight of the jib must be deducted. Refer to the Weight Reduction for Load Handling Devices for proper deducts.

The Lift Capacity Chart assumes the crane will be set on firm ground with the outriggers fully extended, machine level and the rear tires off the ground. In this configuration the crane can lift the capacities as specified on the capacity chart.

⚠ WARNING: NEVER EXCEED THE LIFTING CAPACITY CHART FOR THE CONFIGURATION BEING USED.

Weight Reduction for Load Handling Devices

The weight of any load handling device or boom attachment must be deducted from the lift capacity. Load handling devices are anything added to the line to help handle the load, such as a hookblock, headache ball, sling or spreader bar. If a jib is attached to the boom, either erected, retracted or stowed, its weight must also be deducted from the lift capacity.

The weights listed are for Manitowoc Boom Truck-supplied devices only. If other load handling devices, such as hookblocks, are purchased, they must be weighed and the appropriate weight deducted when in use.

Hook Height Chart

This section indicates the hook height in comparison with boom angle and boom extension. Knowing these variables allows the operator to determine the radius and therefore the lift capacity at any point in the operating range of the crane.

Certain areas are indicated in red as nonoperating areas which must not be entered. Even without a load, if the boom were placed in this position over the side of the truck, the possibility exists for damage or tipover.

Area of Operation

The area of operation decal signifies the allowable area where lifts are allowed. For 180° area of operation, no lifts are allowed in the front (or disallowed area). 360° area of operation allows lifts throughout the full swing area of the crane.

A front-mounted bumper is usually required to provide a 360° area of operation

NOTES TO LIFTING CAPACITIES

Located on each side of the pedestal is the Notes to Lifting Capacities. This placard provides specialized information for different configurations and operating information.

OPERATING THE CRANE

WORK SITE SELECTION

Before setting the crane outriggers, plan the lifts and analyze the job site. The ideal parking area is located as close to the material as possible on firm, smooth, level, dry ground or pavement. It should be free of overhead wires and power lines.

Cribbing may be required to level the crane and provide a firm base.

PREPARATION FOR MACHINE OPERATION

No attempt should be made to operate the crane until a thorough understanding of all instructions pertaining to lifting and lifting capacities has been achieved. In particular, information contained on the following placards must be completely understood.

Load Capacity Chart

This placard contains several sections containing the Lift Capacity Chart, Area of Operation, and Hook Height Chart. Constant reference to the Lift Capacity Chart must be maintained to stay within the parameters of the machine.

Danger, Warning, Caution and Instruction Placards

These are placed at various locations around the machine where they apply. Make sure they are legible and in place before operating the machine.

 **WARNING: DO NOT OPERATE CRANE UNLESS ALL PLACARDS AND DECALS ARE PRESENT AND LEGIBLE.**

Boom Length Marking Tape

Marking tapes are located on each side of the mid-section to indicate actual boom length. It must be remembered that during a lift, the load radius and boom length may change as work progresses. Therefore, constant reference to the load chart should be made.

Notes To Lifting Capacities

This placard, located on each side of the pedestal, provides clarification of the procedures normally followed during the lifting operation.

CRANE FUNCTIONS

All controls should be operated slowly and smoothly so that sudden starting and stopping of a function is avoided and excessive shock loads are not imposed on structural components. Careful use of the appropriate function lever combined with the throttle pedal will ensure smooth and proper crane operation.

Starting the Engine and PTO

⚠ WARNING: INTERNAL COMBUSTION ENGINE EXHAUST GASES CAN BE EXTREMELY DANGEROUS IF EQUIPMENT IS OPERATED IN AN ENCLOSED AREA. OPERATE EQUIPMENT ONLY IN AN ADEQUATELY VENTILATED AREA.

⚠ CAUTION: NEVER CRANK ENGINE FOR MORE THAN 10 SECONDS WHEN STARTING. ALLOW AN INTERVAL OF AT LEAST 30 SECONDS BETWEEN CRANKING PERIODS TO PREVENT STARTER OVERHEATING. REFER TO VEHICLE MANUAL FOR SPECIFIC INSTRUCTIONS.

1. Ensure that transmission is in neutral and park brake is set. Start the engine in accordance with the chassis manufacturer's instructions.
2. With the engine at idle speed, depress the clutch and engage PTO. Slowly release the clutch pedal.

⚠ CAUTION: PTO MUST BE ENGAGED WITH CLUTCH DEPRESSED AT ENGINE IDLE ONLY OR DAMAGE MAY OCCUR TO MAIN HYDRAULIC PUMP OR PTO UNIT.

3. Allow hydraulic oil to warm for several minutes before starting operation of the crane functions.

Note: Start up of hydraulic system with oil temperatures below 0° F (-18° C) is not recommended. If it is necessary to start the system in a sub-zero environment, it will be necessary to heat the oil with a low density, 110 volt AC heater to a minimum of 0° F (-18° C).

Once the engine has been started and operated from the truck cab, it can be stopped and started from either operator's control station.

To stop the engine, push and hold the STOP button until the engine is stopped.

⚠ CAUTION: THE ENGINE MAY CONTINUE TO OPERATE IF THE SWITCH IS PUSHED AND RELEASED TOO QUICKLY.

To start the engine, push and hold the START button until the engine is started.

Note: With the engine off, an electrical draw will still occur. Leaving the engine off for long periods may cause the battery voltage level to drop below the required levels for starting.

Setting A-Frame Outriggers and Stabilizers

Note: Procedures for operating the crane are identical at each operator's control station. Duplicate controls are provided.

1. Ensure that areas in the vicinity of outriggers are clear of personnel and obstacles and pad surfaces are firm.
2. Lower the outriggers using the levers labelled **OUTRIGGER THIS SIDE** and **OUTRIGGER OTHER SIDE**. Use the foot pedal to adjust engine speed as desired. Fully extend outriggers.

IMPORTANT: If necessary, use blocking beneath the outrigger pads to provide adequate support for the weight of the crane.

3. Lower the stabilizers using the levers labelled **STABILIZER THIS SIDE** and **STABILIZER OTHER SIDE**. Use the foot pedal to adjust engine speed as desired. Fully extend stabilizers.

IMPORTANT: If necessary, use blocking beneath the outrigger pads to provide adequate support for the weight of the crane.

4. Use the bubble level indicator to adjust the outriggers and stabilizers until the crane is level. The rear tires must be off the ground when operating the crane.

Setting Out-and-Down Outriggers and Stabilizers

1. Ensure that areas in the vicinity of outriggers are clear of personnel and obstacles and pad surfaces are firm.

⚠ CAUTION: ALWAYS HAVE JACK CYLINDERS FULLY RETRACTED BEFORE MOVING BEAM CYLINDERS.

- Depress and hold the beam button switch on top of the left stabilizer control lever. Push the desired control lever away to extend the beam cylinders. Use the foot pedal to adjust engine speed as desired. Extend the beams completely before releasing lever and beam button.

! WARNING: NEVER OPERATE CRANE WITH BEAMS PARTIALLY EXTENDED.

- Push the control lever for each jack away to lower jack. Lower each jack completely.

IMPORTANT: If necessary, use blocking beneath the outrigger pads to provide adequate support for the weight of the crane.

- Use the bubble level indicator to adjust the outriggers and stabilizers until the crane is level. The rear tires must be off the ground when operating the crane.

Setting the Stabilizer Jack

Note: The procedure for setting the stabilizer jack is the same for a front or rear jack.

! CAUTION: THE JACK CYLINDER HOUSING MUST BE PROPERLY PINNED TO THE MOUNTING BRACKET BEFORE OPERATION.

- Ensure that areas in the vicinity of the stabilizer jack is clear of personnel and obstacles and pad surfaces are firm.

IMPORTANT: If necessary, use blocking beneath the outrigger pads to provide adequate support for the weight of the crane.

- After the outriggers and/or out-and-down stabilizers are set, lower the stabilizer jack
 - Lift and hold the Center Stabilizer toggle switch located on the front of the operator console.
 - Operate the “Street Side” rear stabilizer lever in

ANCHORING WIRE ROPE

Take the free end of the wire rope and insert it through the small opening of the anchor pocket. Loop the wire rope and push the free end about 3/4 of the way through the pocket. Install the wedge, then pull the slack out of the wire rope. The wedge will slip into the pocket and secure the wire rope into the drum.

ROPE SIZE (in)	LENGTH FREE
7/16	3 3/4"
1/2	4 1/2"
9/16	5"
5/8	5 1/2"

INSERT SMALL END FIRST

Wire rope clip must be used with all open wedge socket fittings. Do not clamp free end of wire rope to LOAD LINE (LIVE END) of wire rope.

! WARNING: FAILURE TO USE WIRE ROPE CLIP MAY RESULT IN SERIOUS PERSONAL INJURY OR PROPERTY DAMAGE.

Properly torque wire rope clip after first hour of operation and every 50 hours thereafter.

CLAMP TORQUE	
ROPE SIZE (in)	TORQUE (lb-ft)
7/16	65
1/2	95
9/16	
5/8	

LOAD LINE (LIVE END) MUST BE ON THIS SIDE OF SOCKET

SEIZING ON FREE END OF ROPE

Figure 3-4. Cable Socket and Wedge Installation

the desired direction to raise or lower the center stabilizer. The placard on the console indicates the proper lever.

3. Lower the jack against the cribbing. Exert sufficient force on the jack so that it supports the truck but do not attempt to lift the truck.

⚠ CAUTION: OPERATING THE REAR STABILIZER CONTROL LEVER WITHOUT FIRST ACTIVATING THE TOGGLE SWITCH WILL OPERATE THE REAR STABILIZER AND POSSIBLY BRING THE CRANE OUT OF LEVEL. IF THIS OCCURS, BE SURE TO LEVEL THE CRANE BEFORE THE BOOM IS RAISED FROM THE BOOM REST.

TRANSPORTING THE CRANE

When transporting crane, outriggers and stabilizers must be fully retracted and pads removed (for out-and-downs) and stored. Set the boom in the rest and secure the hook block or headache ball. Disconnect anti-two-block weight from the switch and secure in the transport position.

WIRE ROPE

A new wire rope requires careful installation and proper break-in. After the rope has been installed and the ends secured in the correct manner, the hoist should be started carefully. Run through a cycle of operation at very slow speed. During this trial operation keep a very close watch on all working parts, such as sheaves, drums and rollers, to make certain that the wire rope runs freely and spools on the drum evenly and without any obstructions.

If no problems appear in running the rope, the next step should include several “run-throughs” of the normal operational cycle under light load and at slow speed. This procedure allows component parts of new rope to make a gradual adjustment to actual operating conditions.

OPTIONAL EQUIPMENT

LOAD MOMENT INDICATOR

A Load Moment Indicator is mounted on a swinging arm on the rear of the pedestal. It can swing to either side for viewing from either operator control station. It provides a computerized readout of the various crane parameters which determine the load capacity of the crane. These features include, but are not limited to, load radius, boom length, allowable load, actual load and number of parts of line. Using these parameters, the Load Moment Indicator will determine the ability of the crane to handle the load being lifted.

⚠ WARNING: NEVER RELY ON THE LOAD MOMENT INDICATOR TO DETERMINE LOAD WEIGHT AND CRANE STABILITY. USE THE LOAD CAPACITY CHART TO DETERMINE THE ABILITY TO LIFT A LOAD AT A GIVEN RADIUS BEFORE ATTEMPTING LIFT.

The Load Moment Indicator also works in conjunction with the anti-two-block device, located at the boom nose. The anti-two-block device must be installed and properly operating at all times.

⚠ WARNING: NEVER DISABLE THE ANTI-TWO-BLOCK DEVICE.

Refer to the LMI Operating Manual which is shipped with the machine, for information on setting up, inspecting and operating the Load Moment Indicator.

JIB

Fixed length and two-section telescoping jibs are available for the crane. Mounted to the boom nose, it can be moved into position easily and quickly. When not in use, it can be stored along side the main boom.

As with all items mounted on the boom or wire rope, the jib must be accounted for when calculating lift capacities. Refer to the Lift Capacity Chart for Weight Reduction for Lifting Devices chart when the jib is attached to the boom.

When the jib is installed in an operating position (not stowed) the lift cable must be reeved through the jib nose with the anti-two-block installed on the jib.

Two-section jibs can be used in either the retracted or extended positions. With the jib extended, the reach will be increased but the lift capacity is reduced. Use the appropriate Lift Capacity Chart when the jib is extended or retracted.

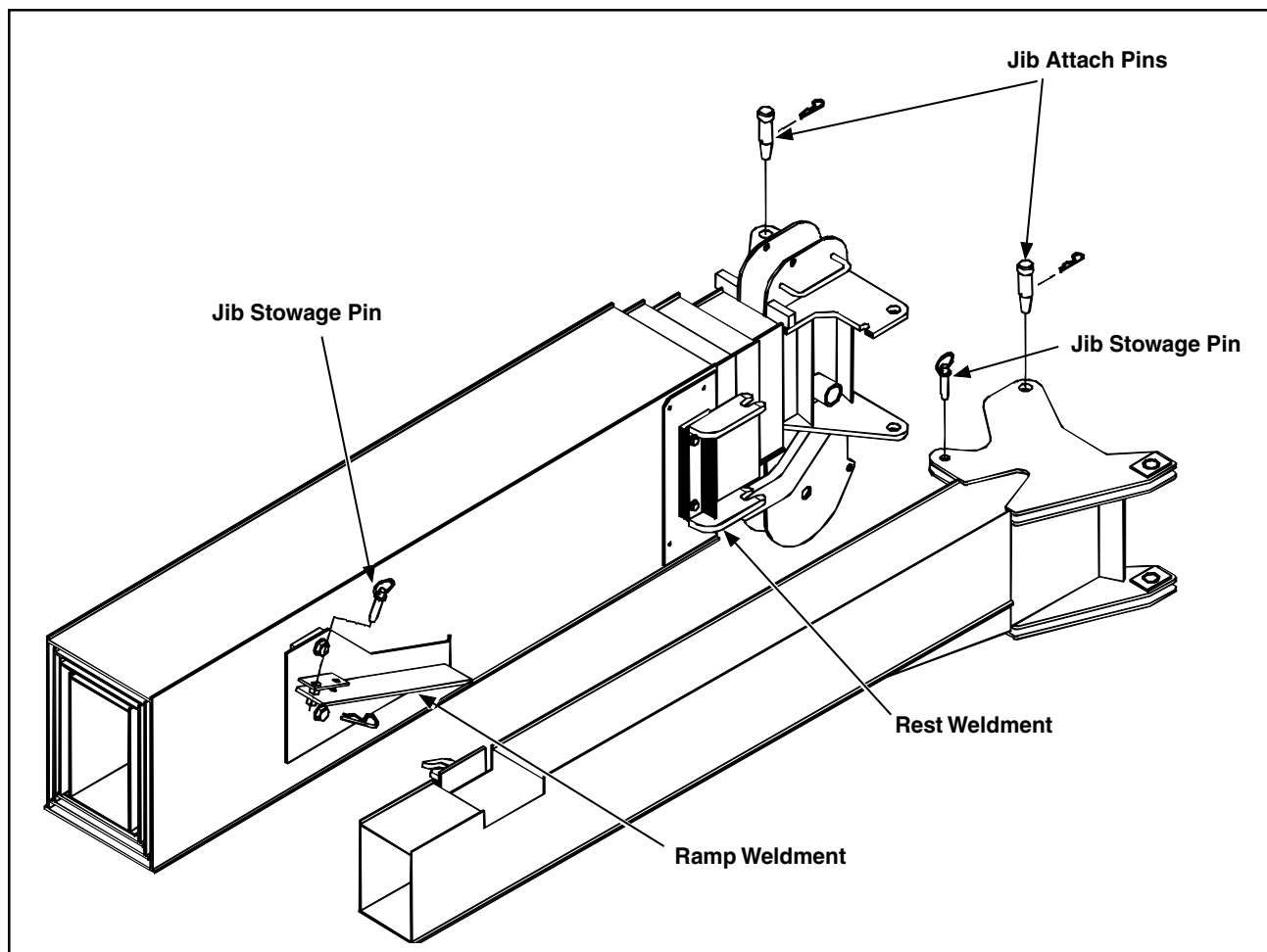

Figure 3-5. Telescoping Jib Pin Installation

Jib Installation

⚠ WARNING: OUTRIGGERS MUST BE SET PRIOR TO JIB INSTALLATION.

⚠ CAUTION: JIB MAY ONLY BE USED WITH SINGLE PART LINE AND DOWNHAUL WEIGHT.

DO NOT TELESCOPE BOOM UNTIL JIB HAS BEEN REMOVED FROM ITS STOWED POSITION AND PROPERLY INSTALLED OR HAS BEEN DETACHED FROM THE BOOM FLY SECTION. SEVERE DAMAGE WILL OCCUR TO BOOM OR JIB AS A RESULT OF PREMATURE TELESCOPE FUNCTION USAGE.

- Using all applicable safety precautions operate the crane systems to raise boom free of boom support and swing boom clear of support.
- Operating the TELESCOPE lever, extend boom three-fourths ($\frac{3}{4}$) total extended length and lower headache ball onto ground or suitable capacity stand.
- Operating the TELESCOPE lever retract boom fully allowing headache ball and cable to stay in extended position. Lower boom to allow access to anti-two-block counterweight and boom head.
- With boom lowered remove two hairpins on anti-two-block switch counterweight. Remove counterweight from around cable but leave counterweight on chain and attached to anti-two-block switch temporarily.
- Remove two hoist cable retaining pins from boom head and temporarily lay cable to left side of boom head, out of the way of jib attach lugs. Reinstall lower cable retaining pin in boom head.

Note: Remove open wedge socket from cable end and unreeve from lower boom nose sheave wheels if crane is reeved for 3 or more parts of line.

6. Operate crane and align jib and boom lug attachment holes on right side of boom head. Install right side upper and lower tapered jib attach pins through boom jib to boom lug attach points. Secure with hairpins.

⚠ CAUTION: DO NOT ATTEMPT TO TELESCOPE BOOM UNTIL JIB STOWAGE PIN IS REMOVED. SEVERE DAMAGE WILL OCCUR TO BOOM AND JIB AS A RESULT OF PREMATURE TELESCOPE FUNCTION.

7. Attach a length of rope to the jib nose before releasing jib stowage pin to aid in swinging the jib into position.

⚠ CAUTION: ENSURE BOOM IS LEVEL DURING REMOVAL OF JIB STOWAGE PIN TO AVOID HAVING THE JIB SWING AWAY FROM THE BOOM STRUCTURE AND STRIKING PERSONNEL.

8. Move boom to horizontal position before attempting to swing jib away from boom structure and have an assistant restrict jib movement with a rope attached to the jib nose. Remove the jib stowage pin located on the ramp weldment of the jib, which secures the jib to the boom base section.

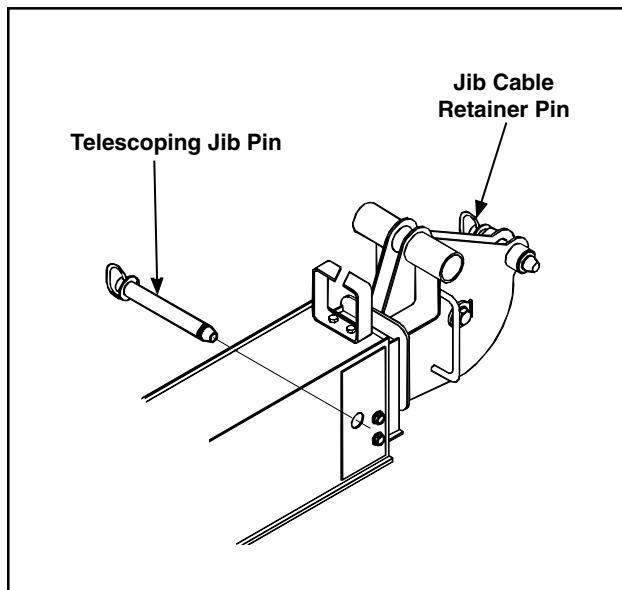

Figure 3-6. Jib Stowage Pins

9. Using all applicable safety precautions activate crane systems and extend boom until both the jib hook clears the ramp weldment and stowage pin clears the rest weldment on the end of the base boom.
10. Using the rope attached to the jib nose, carefully pull jib around until the left side jib and boom nose lug attachment holes are aligned. It may be necessary to lower jib tip to ground to assist in alignment.
11. Insert tapered end of jib attach pins through the jib attach holes. Secure pins using the appropriate cotter pins.
12. Disconnect electrical system from main boom anti-two-block switch and connect jib anti-two-block wiring connector to electrical system on main boom head.
13. Transfer anti-two-block counterweight with chain from main boom head to jib boom head. Attach chain to jib nose and to anti-two-block switch cable and let hang.
14. Remove wing nut from clamp on side of jib and remove anti-two-block electrical wiring from clamp, allowing wiring to hang unrestricted. Reinstall wiring clamp securely on side of jib.

Telescope Jib

If the jib is a telescoping jib, it can be operated in retracted or extended mode. To extend the jib:

1. Remove wing nut from clamp on side of jib and remove anti-two-block electrical wiring from clamp, and allow wiring to hang unrestricted.
2. With boom slightly below horizontal and jib securely attached, remove hairpin which retains the telescoping jib attach pin.
3. Carefully slide fly section from jib base section until hole in fly section aligns with hole in jib base.
4. Reinstall telescoping jib attach pin and secure with hairpin.
5. To retract jib, repeat the above process with the boom slightly raised.

Jib Stowage

1. Using all applicable safety precautions activate crane functions and position boom in an area over the rear of the truck to allow easy access to boom and jib components.
2. Retract boom to within one foot of fully retracted position.
3. Lower headache ball onto ground or suitable capacity stand.
4. Remove two hairpins from jib anti-two-block switch counterweight. Remove counterweight from around cable but leave counterweight on chain and attached to jib nose temporarily.
5. Remove hairpin and cable retainer pin from jib nose. Remove cable from jib sheave and jib cable guide and lay cable to left side of boom. Reinstall cable retainer pin on jib nose.
6. Remove anti-two-block counterweight and chain from jib nose and attach counterweight and chain to main boom head and anti-two-block switch.
7. On main boom head, disconnect jib anti-two-block electrical wiring from main boom electrical system connector. Reconnect main boom anti-two-block switch wiring connector to main boom electrical system connector.
8. Attach a length of rope to jib nose to aid in swinging the jib to the stowed position. Carefully remove the left side upper and lower attach pins from the main boom nose and jib lugs.
9. Using the rope attached to the jib nose, carefully pivot the jib around until the jib is parallel with the base boom.
10. Using all applicable safety precautions activate the crane systems and slowly retract the boom. Ensure that the jib stowage hook on the jib engages with the ramp weldment dowel properly and the stowage pin on jib mounting lug properly engages with the rest weldment on the side of the base boom section as the boom is retracted.
11. Install the jib stowage pin at the ramp weldment on the side of the base boom. Secure the pin with the cotter pin.

⚠ CAUTION: ALWAYS REMOVE RIGHT SIDE ATTACH PINS FROM BOOM NOSE PRIOR TO ATTEMPTING TELESCOPE FUNCTION OR SERIOUS DAMAGE WILL OCCUR TO JIB AND RELATED COMPONENTS.

12. With jib stowed remove remaining right side upper and lower attach pins from the boom nose jib lugs and move them to the opposite (outboard) jib lug holes. Stow the left side upper and lower jib attach pins (already removed) on the left side main boom jib to boom lugs.
13. Using all applicable safety precautions, operate crane systems and extend the boom until all slack is removed from hoist cable.

IMPORTANT: Do not operate hoist until all slack is removed from cable.

14. Remove the upper and lower main boom head cable retainer pins if reinstalled. Reeve cable over sheave wheels for number of parts line required. Reinstall cable retainer pins in boom head.
15. Install anti-two-block counterweight around hoist cable and adjust counterweight chain length to activate switch before two-blocking occurs.
16. Operate crane systems to elevate boom to take up any slack in cable.

IMPORTANT: Do not operate hoist until all slack is removed from cable.

CABLE REEVING

The number of parts of line determine the lift capacity of the hoist. The crane is capable of handling from 1 to 6 parts-of-line. To obtain the maximum amount of permissible rope pull multiple parts-of-line must be run. See the Permissible (Main) Rope Pull section of the Load Capacity Chart for different ratings for each configuration.

The following sections define how to reeve the wire rope for the different parts of line assuming the appropriately sized hookblock is installed with the correct number and size of sheaves.

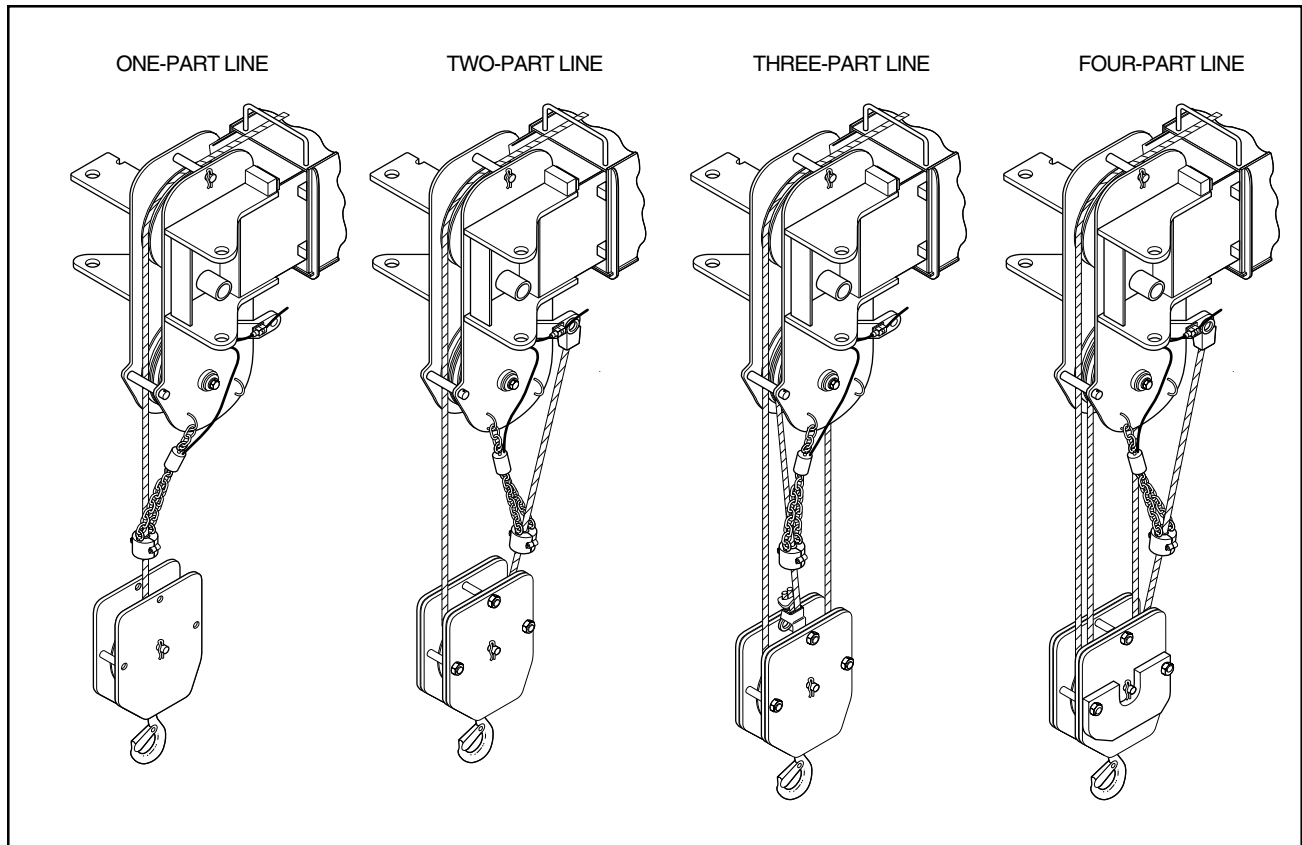

Figure 3-7. Reeving Configurations

Single-Part Line Reeving

1. Lower boom to allow access to boom nose upper and lower sheave wheels and hoist cable retaining pins.
2. Pay out enough hoist cable so end of cable extends beyond boom nose.
3. If not already done, reeve hoist cable through base and mid sections' cable guides on top of boom.

Note: Refer to LMI Operator's Manual for correct reeving through the LMI dynamometer mounted on top of the boom, if equipped.

4. Remove hoist cable retaining pins on boom nose.
5. Reeve hoist cable through boom nose over the upper sheave wheel and lower sheave wheel. The lower sheave wheel must be directly under the upper sheave wheel. Replace hoist cable retaining pins on boom nose.

6. If not already done, install cable socket onto the end of hoist cable as described in Figure 3-7.
7. Attach cable socket to headache ball or hookblock assembly.
8. Reinstall anti-two-block counterweight around the hoist cable (as shown in Fig 3-5) and adjust counterweight chain length to activate cutoff switch before two-blocking occurs. A minimum of 14 in. is recommended.

Two-Part Line Reeving

1. Lower boom to allow access to boom nose.
2. Lower installed headache ball, hookblock or other load handling device onto ground or suitable capacity stand. Remove the cable socket from the load handling device.
3. Remove the anti-two-block counterweight from around the hoist cable and let hang.

4. Reeve hoist cable through hookblock sheave.

Note: Depending upon the type of hookblock the open wedge may need to be removed from the hoist cable to reeve cable through hookblock. Once reeved reattach the open wedge to the hoist cable.

5. Attach cable socket to the lug behind the lower sheave wheel on the boom nose using the pin and pin clip provided.
6. Reinstall the anti-two-block counterweight around the hoist cable. Install counterweight on line at the rear of the boom head (dead end). Adjust counterweight chain length to activate cutoff switch before two-blocking occurs. A minimum of 18 in. is recommended.

Three and Four-Part Line Reeving

Note: Reference to right and left is made with the operator standing on the operator platform facing the controls on the console.

Note: Four-part line requires a two-sheave hookblock.

1. Lower boom to allow access to boom nose.
2. Lower installed headache ball, hookblock or other load handling device onto ground or suitable capacity stand. Remove cable socket from the load handling device.
3. Remove anti-two-block counterweight from around hoist cable and let hang.
4. Remove lower hoist cable retainer pin from boom nose.
5. Reeve hoist cable through hookblock and lower boom sheaves for the desired parts of line. Reeve across right lower sheave first and work across lower boom nose sheaves as desired. For two-sheave hookblocks the cable must be reeved to level the hookblock. See Figure 3-11 for examples of line

reeving.

6. Attach cable socket to the lug on the hookblock (three-part line) or boom nose (four-part line) and secure.
7. Reinstall lower hoist cable retaining pin in boom nose.
8. Reinstall anti-two-block counterweight around hoist cable.

For three-part line install the counterweight on last live line at the rear of the boom head.

For four-part line install the counterweight on dead line at the rear of the boom head.

9. Adjust counterweight chain length to activate cutoff switch before two-blocking occurs. A minimum of 25 in. is recommended.

Five and Six-Part Line Reeving with a Snatch Block

If it is desired to handle higher loads than the four-part lined is rated for, the crane can be equipped with a single sheave snatch block to allow for five and six-part line reeving. The snatch block hangs from the boom nose lug and functions as an additional lower sheave on the boom nose.

Note: Five-part line requires a two-sheave hookblock. Six-part line requires a three-sheave hookblock.

1. Lower boom to allow access to boom nose.

2. Lower installed headache ball, hookblock or other load handling device onto ground or suitable capacity stand. Remove cable socket from the load handling device.
3. Remove anti-two-block counterweight from around hoist cable and let hang.
4. Remove lower hoist cable retainer pin from boom nose.
5. Securely attach snatch block to boom nose lug. Be sure block is oriented properly.
6. Reeve hoist cable through hookblock and lower boom sheaves as if for four-part line. Continue reeving through the snatch block and attach to the hook block lug (five-part line) or the snatch block lug (six-part line).
7. Reinstall lower hoist cable retaining pin.
8. Reinstall anti-two-block counterweight around hoist cable. It may be necessary to add additional length to the counterweight chain. The counterweight must hang at least 14 in. below the snatch block

For five-part line install the counterweight on dead end line going to the hook block.

For six-part line install the counterweight on dead end line going to the snatch block.

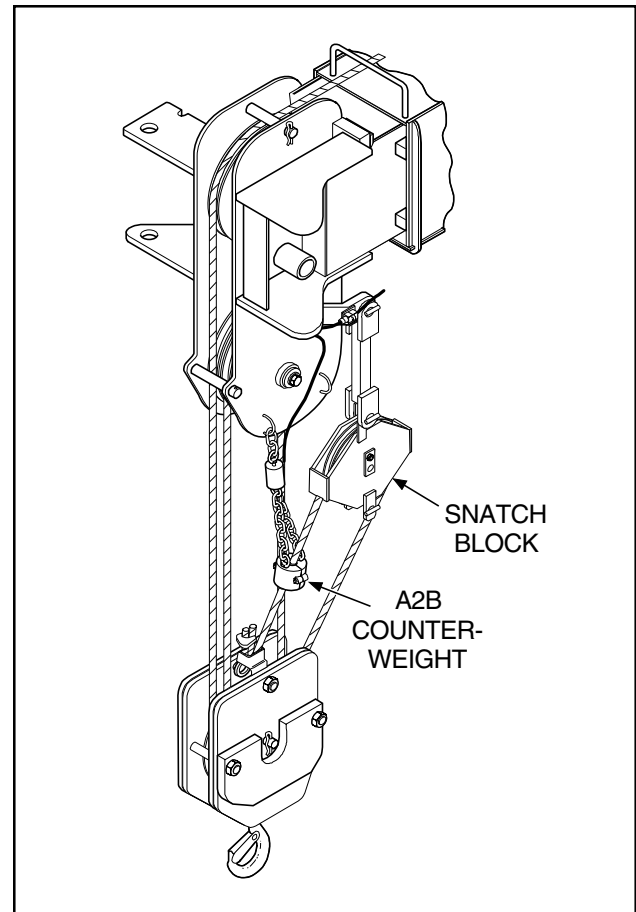

Figure 3-8. Snatch Block Showing Five-Part Line

Additional Options

Radio and platform options are available. Refer to separate manuals for installation and operation of these options.

The following is provided as a guide for simple troubleshooting by the operator when in the field. For more detailed information consult the Service and Maintenance Manual or contact the Manitowoc Boom Truck Customer Service Department.

TROUBLE	PROBABLE CAUSE	REMEDY
Truck engine will not start from console.	PTO not engaged. Faulty PTO switch. Do not have full 12 volt supply to console. Broken or disconnected start switch. Broken or disconnected stop switch. Fuel solenoid requires more than 6 amps to engage.	Engage PTO. Replace PTO switch. Check circuit breaker #2. Replace or reconnect start switch. Replace or reconnect stop switch. Install additional relay in engine compartment as shown on drawing 1282312.
Cannot turn off engine from console.	PTO not engaged. Faulty PTO switch. Faulty stop switch. Stop bypass relay stuck in normally closed position.	Engage PTO. Replace PTO switch. Replace stop switch. Relay not properly grounded through PTO switch.
Outrigger/stabilizer-in-motion alarm will not operate on one or all of the outrigger or stabilizer functions.	Low voltage from main box terminal 13 to common side of micro switch(es). Cam on micro switch(es) out of adjustment.	Ensure 12 volts present. Check continuity of PTO switch. Adjust micro switch(es).
Outrigger/stabilizer-in-motion alarm will operate when outrigger/stabilizer control is in neutral position.	Cam on micro switch(es) out of adjustment. Power wire and signal wire making contact on switch. Faulty micro switch.	Adjust micro switch(es). Repair. Replace micro switch.

TROUBLE	PROBABLE CAUSE	REMEDY
<p>Starter engages when PTO is placed in gear.</p>	<p>Faulty start switch. Truck starter solenoid shorting.</p>	<p>Replace start switch. Repair or replace starter solenoid.</p>
<p>Horn blows when PTO is placed in gear.</p>	<p>Horn switch is defective.</p>	<p>Replace horn switch.</p>
<p>Cannot telescope out or hoist up.</p>	<p>Counterweight is not hanging freely on A2B switch. Low voltage at A2B switch. Low voltage through slip ring in cable reel. A2B connector on boom nose damaged. Faulty A2B switch. Faulty A2B solenoid. Anti-void valve defective.</p>	<p>Remove obstruction or remove chain from transport hook. Check circuit breaker #2 in main electrical box or terminal strips 13-16. Check slip ring for proper installation. Replace connector. Replace A2B switch. Replace A2B solenoid. Replace anti-void valve.</p>

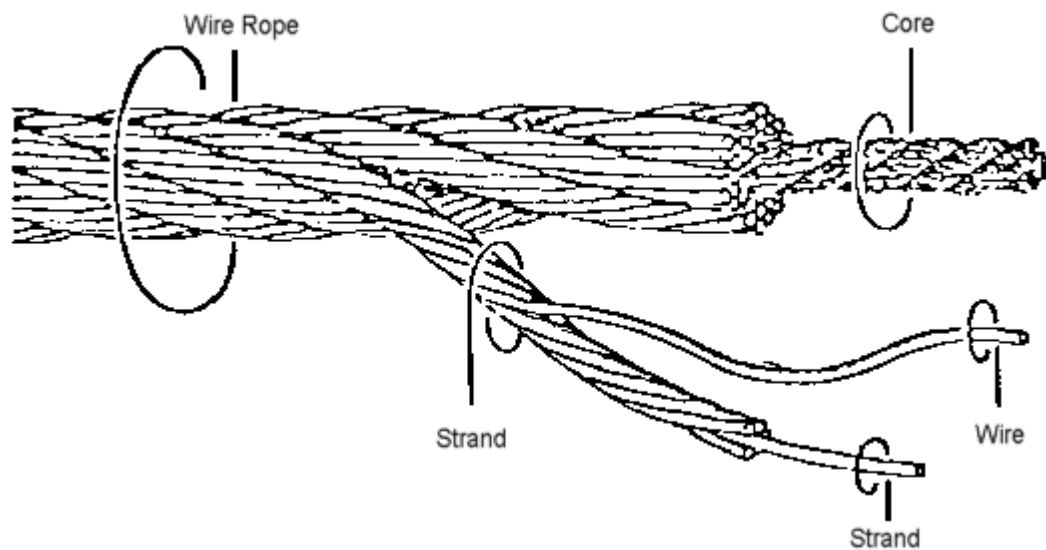

WIRE ROPE

The following information will aid in the care and inspection of wire rope and provide a basic understanding of its construction.

Rope diameters are determined by measuring the circle that just touches the extreme outer limits of the strands. Use the greatest dimension that can be measured using a machinists calipers.

Assurance of safety and economy in use of construction-type machines dictates the requirement for a program of periodic inspections of the condition of all load supporting wire-rope. Environmental and use factors such as abrasion, wear, fatigue, corrosion, improper reeving and kinking, are often of greater significance in determining the safely usable life of wire-rope than are conservative strength factors based on new-rope conditions. Sections A and B of this standard set forth recommended considerations for inspection of wire-rope and a suggested format for recording pertinent observations. The machine operator should inspect wire-rope daily when the machine is in service and prior to operation after a period of standby. Critical inspection of all ropes should be made by a competent rope inspector and pertinent observations recorded not less often than weekly when the trolley boom is in continuous service and prior to operation when the machine is removed from storage.

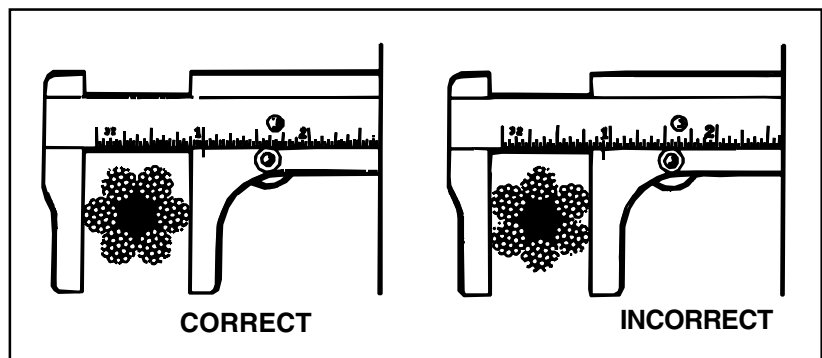

1. Evidence of rope deterioration from corrosion is cause for replacement.
2. More than one broken wire in any one strand is cause for caution. Breaks that occur on the worn crowns of the outside wires indicate normal deterioration. Breaks that occur in the valleys between strands indicate some abnormal condition, possibly fatigue and breakage of other wires not readily visible. One or more valley breaks is cause for replacement.

3. Wire breaks generally occur in those portions of a wire rope which pass over sheaves, wind onto drums, or receive mechanical abuse. Breaks that occur near attached fittings are apt to result from fatiguing stresses concentrated in these localized sections. Breaks of the latter type should be cause for replacement of the rope or renewal of the attachment to eliminate the locally fatigued area.
4. Heavy wear or broken wires may occur in sections under equalizer sheaves or other sheaves where rope travel is limited, or in contact with saddles. Particular care should be taken to inspect ropes at these points.
5. Rope stretch is generally greatest during initial stages of operation when the strands are becoming adjusted and seated. This is accompanied by some reduction in rope diameter, but not to the extent that the condition of the rope can be judged on this basis.
6. Time for rope replacement is indicated by the extent of abrasion, scrubbing and peening on the outside wires, broken wires, evidence of pitting or severe corrosion, kink damage, or other mechanical abuse resulting in distortion of the rope structure.
7. Sheaves, guards, guides, drums, flanges and other surfaces contacted by wire rope during operation should be examined at the time of inspections. Any condition harmful to the rope in use at the time should be corrected. The same equipment, and particularly sheave and drum grooves, should be inspected and placed in proper condition before a new rope is installed.
8. Any of the following listed conditions should be cause for rope replacement:
 - (a) In running ropes, six randomly distributed broken wires in one rope lay, or three broken wires in one strand in one rope lay. (A rope lay is the length along the rope in which one strand makes a complete revolution around the rope.)
 - (b) In pendants or standing ropes, evidence of more than one broken wire in one rope lay.
 - (c) Abrasion, scrubbing or peening causing loss of more than 1/3 the original diameter of the outside wires.
 - (d) Evidence of rope deterioration from corrosion.
 - (e) Severe kinking, severe crushing, or other damage resulting in distortion of the rope structure.
 - (f) Evidence of any heat damage resulting from a torch or arc caused by contact with electrical wires.
 - (g) Reduction from nominal diameter of more than 3/64 in. for diameters up to and including 3/4 in.; 1/16 in. for diameters 7/8 to 1-1/8 in.; 3/32 in. for diameters 1-1/4 to 1-1/2 in. Marked reduction in diameter indicates deterioration of the core resulting in lack of proper support for the load carrying strands. Excessive rope stretch or elongation may also be an indication of internal deterioration.
 - (h) Evidence of "bird-caging" or other distortion resulting in some members of the rope structure carrying more load than others.
 - (i) Noticeable rusting or broken wires in the vicinity of attachments.

NOTE: If this condition is localized in an operating rope and the section in question can be eliminated by making a new attachment, this can be done rather than replacing the entire rope.

BOLT TORQUE SPECIFICATIONS

SIZE TPI BOLT DIA TENSILE STRESS AREA				VALUES FOR ZINC PLATED FASTENERS ONLY										
				SAE GRADE 5 BOLTS & GRADE 2 NUTS					SAE GRADE 8 BOLTS & GRADE 8 NUTS, & SOCKET HEAD CAP SCREWS					
				CLAMP LOAD (LB)	TORQUE DRY OR LOCTITE 263 (LB _f -IN)	TORQUE LUBE (LB _f -IN)	TORQUE LOCTITE 262 (LB _f -IN)	TORQUE LOCTITE 242 OR 271 (LB _f -IN)	CLAMP LOAD (LB)	TORQUE DRY OR LOCTITE 263 (LB _f -IN)	TORQUE LUB (LB _f -IN)	TORQUE LOCTITE 262 (LB _f -IN)	TORQUE LOCTITE 242 OR 271 (LB _f -IN)	
4	40	0.1120	0.00604	380	8	6				540	12	9		
	48	0.1120	0.00661	420	9	7				600	13	10		
6	32	0.1380	0.00909	580	16	12				820	23	17		
	40	0.1380	0.01015	610	18	13				920	25	19		
8	32	0.1640	0.01400	900	30	22				1260	41	31		
	36	0.1640	0.01474	940	31	23				1320	43	32		
10	24	0.1900	0.01750	1120	43	32				1580	60	45		
	32	0.1900	0.02000	1285	49	36				1800	68	51		
1/4	20	0.2500	0.0318	2020	96	75		105		2860	144	108		160
	28	0.2500	0.0364	2320	120	86		135		3280	168	120		185
5/16	18	0.3125	0.0524	3340	(LB _f -FT) 17	(LB _f -FT) 13	(LB _f -FT) 16	(LB _f -FT) 19		(LB _f -FT) 4720	(LB _f -FT) 25	(LB _f -FT) 18	(LB _f -FT) 22	(LB _f -FT) 30
	24	0.3125	0.0580	3700	19	14	17	21		5220	25	20	25	30
3/8	16	0.3750	0.0775	4940	30	23	28	35		7000	45	35	40	50
	24	0.3750	0.0878	5600	35	25	32	40		7900	50	35	45	55
7/16	14	0.4375	0.1063	6800	50	35	45	55		9550	70	55	63	80
	20	0.4375	0.1187	7550	55	40	50	60		10700	80	60	70	90
1/2	13	0.5000	0.1419	9050	75	55	68	85		12750	110	80	96	120
	20	0.5000	0.1599	10700	90	65	80	100		14400	120	90	108	135
9/16	12	0.5625	0.1820	11600	110	80	98	120		16400	150	110	139	165
	18	0.5625	0.2030	12950	120	90	109	135		18250	170	130	154	190
5/8	11	0.6250	0.2260	14400	150	110	135	165		20350	220	170	180	240
	18	0.6250	0.2560	16300	170	130	153	190		23000	240	180	204	265
3/4	10	0.7500	0.3340	21300	260	200	240	285		30100	380	280	301	420
	16	0.7500	0.3730	23800	300	220	268	330		33600	420	320	336	465
7/8	9	0.8750	0.4620	29400	430	320	386	475		41600	600	460	485	660
	14	0.8750	0.5090	32400	470	350	425	520		45800	660	500	534	725
1	8	1.0000	0.6060	38600	640	480	579	675		51500	900	680	687	990
	12	1.0000	0.6630	42200	700	530	633	735		59700	1000	740	796	1100
1 1/8	7	1.1250	0.7630	42300	800	600	714	840		68700	1280	960	1030	1400
	12	1.1250	0.8560	47500	880	660	802	925		77000	1440	1080	1155	1575
1 1/4	7	1.2500	0.9690	53800	1120	840	1009	1175		87200	1820	1360	1453	2000
	12	1.2500	1.0730	59600	1240	920	1118	1300		96600	2000	1500	1610	2200
1 3/8	6	1.3750	1.1550	64100	1460	1100	1322	1525		104000	2380	1780	1907	2625
	12	1.3750	1.3150	73000	1680	1260	1506	1750		118100	2720	2040	2165	3000
1 1/2	6	1.5000	1.4050	78000	1940	1460	1755	2025		126500	3160	2360	2530	3475
	12	1.5000	1.5800	87700	2200	1640	1974	2300		142200	3560	2660	2844	3925

Note: These torque values do not apply to cadmium plated fasteners.

BOLT TORQUE SPECIFICATIONS (CONTINUED)

				SOCKET HEAD SCREWS					
				UNBRAKO 1960 SERIES SOCKET HEAD			KERR-LAKESIDE SOCKET HEAD		
SIZE	TPI	BOLT DIA (IN)	TENSILE STRESS AREA (IN ²)	CLAMP LOAD (LB)	TORQUE AS RECEIVED w/o LOC-WEL PATCH (LB-FT)	TORQUE AS RECEIVED w/ LOC-WEL PATCH (LB-FT)	TORQUE LOCTITE 262 (LB-IN)	TORQUE LUBRICATED w/ LOC-WEL PATCH (LB-FT)	TORQUE DRY w/ LOC-WEL PATCH (LB-FT)
4	40	0.1120	0.00604						
	48	0.1120	0.00661						
6	32	0.1380	0.00909						
	40	0.1380	0.01015						
8	32	0.1640	0.01400						
	36	0.1640	0.01474						
10	24	0.1900	0.01750						
	32	0.1900	0.02000						
1/4	20	0.2500	0.0318	3180	13	14			
	28	0.2500	0.0364	3640	14	15			
5/16	18	0.3125	0.0524	5240	25	28	22	21	25
	24	0.3125	0.0580	5800	27	30	25	24	32
3/8	16	0.3750	0.0775	7750	45	50	40	38	50
	24	0.3750	0.0878	8780	50	55	45	43	55
7/16	14	0.4375	0.1063	10630	70	77	63	61	81
	20	0.4375	0.1187	11870	75	82	66	66	91
1/2	13	0.5000	0.1419	14190	110	120	96	93	124
	20	0.5000	0.1599	15990	115	127	105	105	140
9/16	12	0.5625	0.1820	18200	155	170	145		
	18	0.5625	0.2030	20300	165	182	150		
5/8	11	0.6250	0.2260	22600	210	231	170	178	236
	18	0.6250	0.2560	25600	220	242	190	203	270
3/4	10	0.7500	0.3340	33400	365	400	290	317	423
	16	0.7500	0.3730	37300	400	440	320	354	472
7/8	9	0.8750	0.4620	46200	585	645	480	512	682
	14	0.8750	0.5090	50900	635	700	510	563	751
1	8	1.0000	0.6060	60600	865	950	660	775	1022
	12	1.0000	0.6630	66300	915	1000	730	839	1118
1 1/8	7	1.1250	0.7630	76300	1240	1365	1000	1065	1448
	12	1.1250	0.8560	85600	1380	1520	1110	1203	1531
1 1/4	7	1.2500	0.9690	96900	1750	1925	1400	1535	2047
	12	1.2500	1.0730	107300	1880	2070	1510	1689	2265
1 3/8	6	1.3750	1.1550	115500	2320	2550	1860	2011	2681
	12	1.3750	1.3150	131500	2440	2685	1940	2295	3060
1 1/2	6	1.5000	1.4050	140500	3040	3345	2430	2672	3562
	12	1.5000	1.5800	158000	3270	3600	2610	2995	3994

Note: These torque values do not apply to cadmium plated fasteners.

NOTES:

Item	Page	Item	Page
Anti-Two-Block Device	3-5	Preparation for Use	2-1
Area of Operation	3-7	Safe Distances from Power Lines	1-1
Authorized Operating Personnel	3-1	Safety Symbol	Inside Front Cover
Boom Angle Indicator	3-5	Setting A-Frame Outriggers and Stabilizers	3-8
Boom Length Marking Tape	3-7	Setting Out-and-Down Outriggers and Stabilizers	3-8
Burst-of-Speed	3-5	Single-Part Line Reeving	3-13
Cable Reeving	3-13	Start Switch	3-5
Capacities and Stabilization	3-1	Starting the Engine and PTO	3-8
Control Placards	3-1	Stop Switch	3-5
Controls and Indicators	3-2	Telescope Control	3-3
Crane Functions	3-8	Telescope Jib	3-12
Crane Level Indicator	3-5	Three-Part and Four-Part Line Reeving	3-15
Daily Check Points	2-2	Throttle Control	3-5
Danger, Warning, Caution and Instruction Placards	3-7	Transporting the Crane	2-5, 3-9
Driving Safety	1-6	Troubleshooting	4-1
Drum Rotation Indicator	3-5	Two-Part Line Reeving	3-14
Engine Stop Switch	3-5	Warranty	Inside Back Cover
Federal Regulations	1-1	Weight Reduction for Load Handling Devices	3-7
Hand Signals for Boom Movement	1-7	Wire Rope	3-9, A-2
Hook Height Chart	3-7	Wire Rope Safety	1-6
Horn Switch	3-5	Work Site Selection	3-7
Ignition Switch	3-5		
Indicators and Engine Controls	3-5		
Jib	3-10		
Jib Installation	3-10		
Jib Stowage	3-12		
Lift Capacity Chart	3-6, 3-7		
Load Chart	3-6		
Load Handling Safety	1-4		
Load Lifting Safety	1-3		
Load Moment Indicator	3-5, 3-10		
Machine Inspection Requirements	2-1		
Modifying the Machine	1-1, 2-1		
Notes to Lifting Capacities	3-7		
Operating Area Safety	1-5		
Operating Characteristics and Limitations	3-1		
Operating Safety	1-5		
Operating the Crane	3-7		
Operator's Daily Checklist	2-3		
Optional Equipment	3-10		
Outrigger Controls	3-3		
Outrigger and Stabilizer Types	3-4		
Outrigger/Stabilizer Safety	1-4		
Outrigger-In-Motion Alarm	3-4		
Overload System	3-5		
Periodic Inspection	2-4		
Placards and Decals	3-6		
Preparation for Machine Operation	3-7		

CRANE WARRANTY



1. WARRANTY. Manitowoc Boom Trucks, Inc., (“Manufacturer”) warrants each new product made by it to be free from defects in material or workmanship for TWELVE months from the date of initial sale, lease, rental or other disposition of such product. Manufacturer agrees only to repair or replace at its own expense, F.O.B. the place or places of manufacture, any part or parts of the product found to be defective in material or workmanship, provided Manufacturer is notified of such defect or defects within the applicable warranty period and given a reasonable time to correct the defect. In no case shall any warranty extend to defects in materials, components, or services furnished by third parties or to the erection or installation of the product performed by third parties. Defects caused by chemical action or the presence of abrasive materials and defects arising following the operation beyond rated capacity or the improper use or application of any products shall not be considered defects within the scope of the above mentioned warranty. If any repairs or alterations are made or any parts are replaced during the periods covered by any warranty above mentioned by other than an authorized Manufacturer’s Distributor in accordance with authorized Manufacturer’s service manuals or with other than parts, accessories, or attachments authorized by Manufacturer for use in its products, customer shall pay for such repairs or parts without recourse against Manufacturer, and Manufacturer shall be relieved of responsibility for fulfillment of the above mentioned warranty with respect to parts or components for all repairs, alterations, or replacements so made. Manufacturer’s obligations under this warranty shall at all times be subject to its then current warranty policies and procedures. The above mentioned warranty shall not apply to replacement or service parts made by and sold by Manufacturer, with any obligation of the Manufacturer to such parts governed solely by Manufacturer’s then current warranty policies and procedures.

2. DISCLAIMER AS TO CONSEQUENTIAL OR SPECIAL DAMAGES. Under no circumstances shall the Manufacturer be liable for any consequential or special damages which any person, firm, corporation, or other entity may suffer or claim to suffer or incur or claim to incur as a result of any defect in the product or in any correction or alteration thereof made or furnished by Manufacturer or others. “Consequential” or “special damages” as used herein includes but is not limited to costs of transportation, lost sales, lost orders, lost profits, lost income, increased overhead, labor and material costs, and costs of manufacturing variances and operational inefficiencies.

3. MAXIMUM LIABILITY. The maximum liability of Manufacturer under the exclusive warranty set forth herein shall be the amount paid to Manufacturer with respect to the product to which such warranty applies.

4. EXCLUSIVE AND ENTIRE WARRANTY. This warranty constitutes Manufacturer’s entire warranty as to the product and it is agreed that the remedies of customer and those claiming under customer as stated in this warranty are exclusive. Manufacturer does not assume (and has not authorized any other person to assume on its behalf) any other warranty or liability in connection with any product covered by this warranty. MANUFACTURER EXPRESSLY DISCLAIMS ANY AND ALL OTHER WARRANTIES OF ANY KIND WHATSOEVER AS TO THE PRODUCT FURNISHED HEREUNDER, INCLUDING BUT NOT LIMITED TO EXPRESS OR IMPLIED WARRANTIES AS TO MERCHANTABILITY, FITNESS FOR PARTICULAR PURPOSES SOLD, DESCRIPTION OR QUALITY OF THE PRODUCT FURNISHED HEREUNDER.

5. NOTICE OF OCCURRENCE. This warranty shall be void if, upon the occurrence of any incident involving any product made by Manufacturer and resulting in any personal injury or property damage, customer shall fail to notify Manufacturer within 48 hours of such occurrence or permit Manufacturer and its representatives to have immediate access to such product and to all records of or within the control of customer relating to the product and occurrence.

6. LIMITATION OF LIABILITY. The limitation of liability provisions herein shall apply to any and all claims or suits brought against Manufacturer including any claim based upon negligence, breach of contract, breach of warranty, strict liability, or any other legal theories upon which liability may be asserted against Manufacturer.

Manufacturer may at any time amend the foregoing form of warranty without prior notice.