

VOLVO ARTICULATED HAULERS

**A25C 4X4, A25C, A25C CONTAINER,
A25C LIGHT MATERIAL, A30C**



VOLVO

They work day after day

Volvo's articulated haulers are at work all over the world, round the clock, in increasingly diverse applications. In many cases, they have been chosen for the task because other methods have been tried and simply haven't worked. Harsh climate, difficult terrain, high demands on availability – these are factors that have influenced the choice of Volvo articulated haulers.

Construction of high-speed trains in Europe, work under ground in South America and haulage at an open-cast mine in Africa – these are just three examples from a steadily growing number of applications.

Borderless Europe needs transport networks

The need for better and faster transport is becoming increasingly urgent in Europe, and enormous resources are being invested in expansion of the infrastructure.

A huge project has been completed in southern Belgium to prepare the way for the high-speed TGV-trains which link a growing number of European capitals.

No less than 3.3 million cubic yards of surplus soil had to be excavated and moved to the dumping site, an abandoned mine. The haul distance was about 2.2 miles, and from the start it was planned that the job would be done by conventional trucks. But a combination of muddy, clayey and slippery soil and demanding conditions on both the loading and dumping sites made this impossible. The trucks simply couldn't get through, nor could they dump at the right place. The solution was to use 65 Volvo articulated haulers, working double shifts or more to get the job done. The results were very good. The contractors were all very pleased with their haulers, and even though they were operated for as much as 320 hours a month, reliability was very high. Their outstanding off-road mobility was also a very valuable asset. The haul surface is muddy clay, extremely

slippery when wet, but the haulers kept production going regardless of conditions.

Sweaty in Zimbabwe

Temperatures over 104°F and slopes with a 12% gradient, 20 hours a day, five days a week – this is the situation faced by four Volvo A25Cs in the Sanyati Copper Mine in Zimbabwe.

The articulated haulers are loaded with shot rock, which is hauled 0.5 mile to the concentration plant. The haul run is downhill, with a gradient of up to 12%. The retarder comes in very handy here.

To minimize wear on the brakes, the operators are encouraged to use the retarder as much as possible. And with experienced operators this works very well, so well that the brakes virtually never need to be used.

Under ground in Chile

Three Volvo A25Cs work round the clock in a 1.2 mile long haulage tunnel in a copper mine in Chile. They run continuously from the tunnel face out to the portal, where a couple of Volvo wheel loaders take over. Thanks to their low-emission engines, the articulated haulers can operate continuously down in the mine passageway, without jeopardizing the environment for those who work there.



Despite this very tough schedule, reliability has been 100 percent, largely thanks to the fact that maintenance and inspections have been planned and carried out with great thoroughness. Easy daily checkup routines for the operator is another factor that keeps reliability high.



The articulated hauler method

When Volvo introduced the articulated hauler in the 1960's it was not just another machine. Soon the market realized that the articulated hauler introduced a new method in haulage.

The use of Volvo articulated haulers has led to a whole new way to plan a work-site and carry out haulage. It is by truly exploiting all the features of the articulated hauler that the work can be made more efficient:

- All-terrain – able to choose the shortest route, even with a full load, and able to work under virtually all conditions.
- Easy to maneuver – comes quickly into position for loading and unloading.

- Dumps over the edge – can usually manage without help on the dumping site.

Today the two basic models of Volvo articulated haulers, A25C and A30C, fulfill their mission in a lot of different countries and work-sites. Which model that is used is basically an economic question. Factors that influence the choice are the relation between payload capacity and loading capacity, haulage distances and the demand for flexible use of the articulated hauler.

Right partner

The articulated hauler has a very wide range of applications. It can handle haul distances from 0.1 mile up to several miles, sometimes even longer, with ease and efficiency. On or off-road, level ground or steep slopes, the versatility of the articulated hauler is great and always makes it worth considering as an alternative. Choosing the right equipment to use in combination with the articulated hauler, and never mixing different hauler sizes in the same fleet, are other important considerations.



Loading options

A hydraulic excavator is the most common, and in most cases, the most efficient loading option. Excavator and hauler are combined so that the body is filled with 3-5 buckets. A wheel loader may be the most efficient choice for loading loose materials. It moves rapidly and can load a hauler quickly with its big bucket.

Conveyor belts, silos and other stationary equipment are also excellent choices for loading an articulated hauler. Because the hauler is so easy to maneuver, the operator can quickly get into the right position and just as easily get out with a full load.



Hauling with load

This is perhaps the strongest side of the articulated hauler. Volvo articulated haulers can get to where they're going under most conditions. The need to build and maintain haul roads is minimal.

Articulated steering and the frame joint are the keys to this off-road mobility. They are what enable the tractor and trailer units to move independently of each other and eliminate the stresses on the frame. They also make the machine very easy to operate.

Six-wheel drive, diff-locks on all axles, and automatic transmission are Volvo features that give the articulated haulers unequalled off-road mobility. The front axle suspension and the Volvo bogie cushion both the load and the operator for a safe and comfortable ride.

The machine can go almost anywhere, and is fast and efficient on construction roads as well.

Unloading

Volvo articulated haulers can dump their loads at exactly the right place. In most cases, they need no assistance from crawler dozers or other machines.

Its off-road characteristics and big wheels with low ground pressure, enable the articulated hauler to get into position quickly and safely, without the risk of getting stuck.

Once in position, the machine tips quickly, with a body angle of up to 70 degrees. The hydraulic system is double-acting, so the body can be lowered even if the hauler is on an uphill grade. Thanks to the terrain bogie, the high tipping joint, and the chute that guides the material out of the body, it is easy to dump over an edge, directly down into a pit, a hopper or down a slope.



Modification of the body

Certain types of loads or loading methods require modification of the body on the articulated hauler. A spill guard at the front edge of

the body protects the cab and the operator, a wire-operated tailgate reduces the risk of spillage during haulage. Heating of the bottom of the body greatly reduces the risk that the load will stick under certain operating conditions. The exhaust gases are used for body heating, which means no extra energy is consumed.

Standard solution for specialized applications

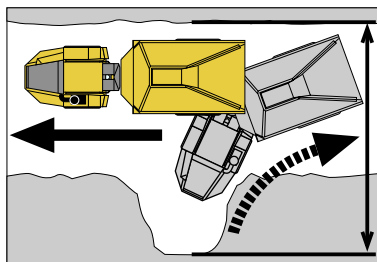
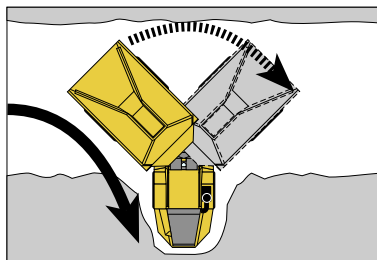

The articulated hauler is basically constructed for hauling of earth and other masses. During the years Volvo's articulated haulers has proven their availability, flexibility and capacity which has resulted in interest in using the articulated haulers in other applications. On this basis, Volvo has developed a range of slightly modified articulated haulers for different purposes.

Volvo A25C 4x4

The four-wheeled Volvo A25C is the perfect alternative for stationary jobs and underground. In its standard version, it is used in a great

many mines and tunnels. Equipped with turnaround wheels, it can turn in only 31 ft which makes it outstanding in cramped work-sites.

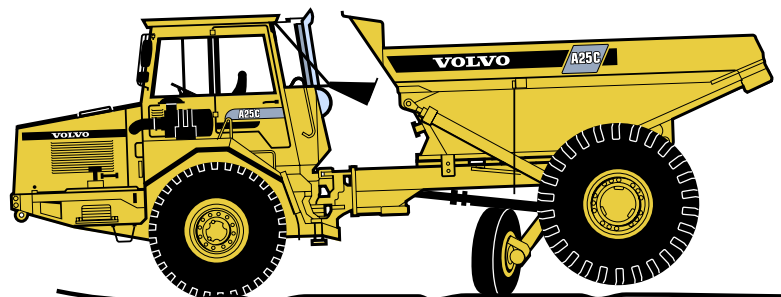



Volvo A25C Container

The Volvo A25C can be equipped to carry a container, which makes it highly effective in waste handling operations. With its light ground pressure, off-road mobility and maneuverability, it can negotiate on the landfill and dump the garbage at the right place. These features have made the Volvo A25C Container interesting in other applications where the needs are similar.

Volvo A25C Light material

A Volvo A25C can be equipped with a larger body than usual. This enables the articulated hauler to carry loads up to 31.4 yd³ as long as the material transported has a density of maximum 1.5 lb/yd³.

Volvo A25C Light material is, for example, ideal for transporting coal and other material with low weight but large volume.



Operator in the center - literally

The operator is without a doubt one of the most important components in an efficient articulated hauler. An ergonomical, safe and comfortable operator's environment makes it simple to operate the hauler at a high level of efficiency.

The operator sits straight above the front axle, midway between the wheels. This puts him at the

mid-point of the machine, where the cab's movements are minimal. Visibility all around is excellent, steering is precise and the automatic transmission saves more than 150 shifts every hour. Engagement and disengagement of the diff-locks and driving wheels is performed logically via ergonomically correct controls.

Volvo articulated haulers are eminently well-equipped in their standard version for most applications. But for those who have special requirements or work in a severe climate or other special conditions, there is a rich variety of equipment and accessories. We show the most popular ones here – the complete range is even broader.





Contronic – the key to better economy

Volvo Contronic maintains a watchful eye over your hauler. Contronic monitors and protects the engine, drive-train and brakes. It keeps track of service needs and reduces the risk of unscheduled downtime.

Contronic can also furnish information on machine operation. It records distance travelled, running time and number of cycles since the last resetting – information which helps you keep track of the work done.

A detailed cab display gives the operator information on, among other things, running time, distance travelled, time of next service and much more.

Higher comfort

Air conditioning makes the cab pleasantly cool on hot days. The system is efficient, reliable and uses CFC-free refrigerant. The air-sprung operator's seat is perfect for driving on uneven terrain and the electrically heated rear-view mirrors provide added safety during work in damp and cold weather.

Filters for dusty conditions

During work in extremely dusty conditions, extra filtration of the intake air may be necessary. An oil bath filter with very high capacity is available as an accessory, as well as a coolant filter. An extra fuel filter is used when the fuel is of doubtful quality.



Advanced technology for good economy

- Genuine Volvo diesel engines
- Unique frame and steering joint
- Suspension in front, bogie in rear
- Drive on all wheels and 100% diff-locks
- Automatic transmission
- Efficient brakes and wear-proof retarder
- Tires that gives a low-ground pressure
- Hydromechanical steering – exact and with good feel

Volvo articulated haulers are developed and built for demanding hauling under tough conditions. Every detail is made to fill its particular function. Volvo has led the development of technology in this field from the very start. Thanks to this carefully engineered and thoroughly tested concept, Volvo's articulated haulers provide unmatched reliability, productivity and economy – in both the short and long run.

Genuine Volvo diesel engines

Volvo's in-line six-cylinder direct-injected four-stroke diesel engines with turbocharger and intercooler are the choice for all models. An excellent basic design providing high power outputs, high torque, low emissions and long life.

The engines have displacements of 7, 10 and 12 liters and have been completely adapted to the requirements of an articulated hauler. The torque is high even at low engine speeds for quick acceleration

response, which is particularly important in difficult off-road conditions. Within the engine's normal working range, the torque increases when the engine speed decreases. This boosts the tractive force when the hauler meets resistance, for example, on an uphill grade. Maximum rpm is relatively low, which leads to lower fuel consumption, less noise and longer life.

Turbocharging with intercooler provides efficient combustion with high power and low emissions. Cooling is very efficient with a hydraulically powered and thermostat-controlled radiator fan, with low power losses for the engine.

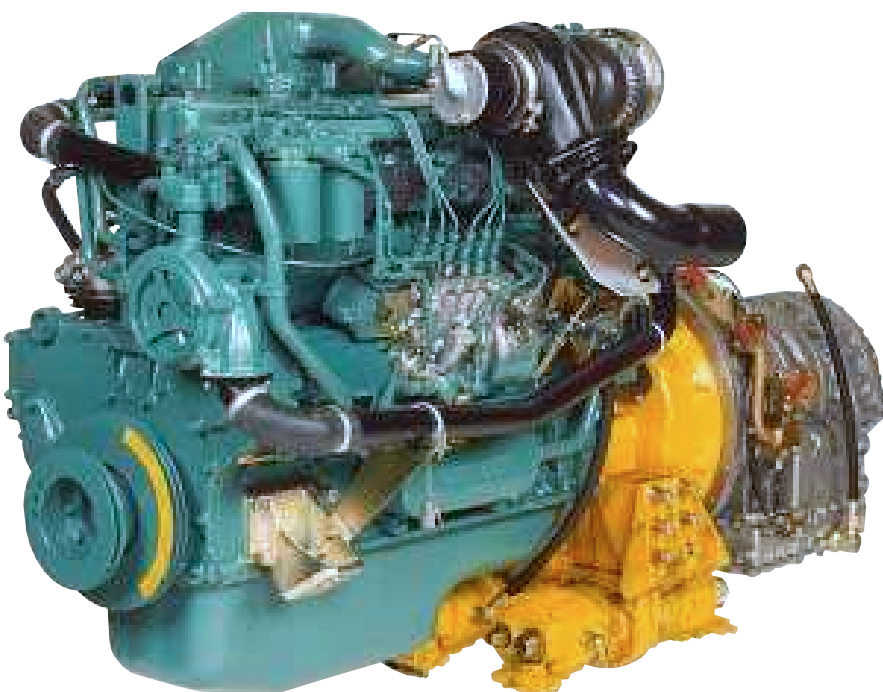

Torque curve





In the environment in which articulated haulers are normally used, efficient air filters are a must. Here there is also a second-stage filter that goes into action in emergencies and a warning lamp that tells the operator of the clogged filter.

Efficient brakes and wear-proof retarder

Volvo articulated haulers have an ability to get just about anywhere they're going - for example up and down steep hills, which makes great demands on brake capacity. Disc brakes offer high capacity and safety. In combination with the hydraulic retarder, the brakes are also long-lived.

The retarder is integrated in the transmission and is used to reduce or maintain constant speed on downhill grades. The braking effort can be infinitely varied, and since the retarder is hydraulic it virtually never wears out.

Tires with low ground pressure

The tires on the modern articulated hauler exert very low ground pressure, which is important at loading and dumping sites. The normal tires have an 80 profile and a tread pattern that makes them suitable both off the road and on the road. For particularly difficult conditions, when extra-low ground pressure is needed, there are tires with a 65 profile in certain sizes, as well as extra-tough tires for stony terrain.

Body and tipping

The body with large tipping angle and short tipping times enhances productivity. Being able to dump at exactly the right place quickly and easily is very important. The body is very sturdy and strong and prepared for exhaust gas heating. This reduces the risk that the load will freeze or get stuck.

Tipping takes about 15 seconds with a full load, and the body can be tipped to an angle of 70 degrees. Furthermore, the body dumps the load free of the machine, making it possible to put the load exactly where you want it, even directly over an edge, without the aid of other machines.



Unique frame and steering joint

What makes the articulated hauler unique, and distinguishes it from other haulage vehicles, is the frame joint and the steering joint. The frame joint connects the front and rear frames together and rotates 360°. The tractor and trailer sections move independently of one another, reducing the stresses in off-road operation and keeping the wheels in contact with the ground. Thanks to the function of the frame joint, the frame can be made properly stiff and strong.

The steering joint makes articulated steering possible, which makes the hauler very easy to maneuver in small spaces. Articulated steering also enables the operator to get loose from mud and muck by utilizing the steering force and "slithering" from side to side with the tractor section.

Exact steering

The steering on Volvo's articulated haulers is hydromechanical, self-compensating which provides very good "driving feel" – equal to that of

a modern truck. The steering angle is always the same for a given turn of the wheel, making the machine easy to drive. An important safety feature is that the hauler can always be steered as long as the wheels are rolling, even if the engine is dead.

Suspension and bogie

The front axle with three-point suspension and the terrain bogie are unique Volvo features. The front axle has robust maintenance-free rubber springs. Together with the shock absorbers, they make it possible to maintain a high average speed over difficult terrain, with undiminished operator comfort and low stresses on the machine.

Each bogie axle is suspended at three points, a solution which permits each wheel pair to move freely and the body to "float" over the ground irregularities. Compared with other systems, the three-point suspension provides greater freedom for the wheel pairs to move individually, reducing the stresses on the frame. The Volvo bogie also permits high ground clearance, and the drive axles are well protected. The design is simple without lube points and is in principle maintenance free.

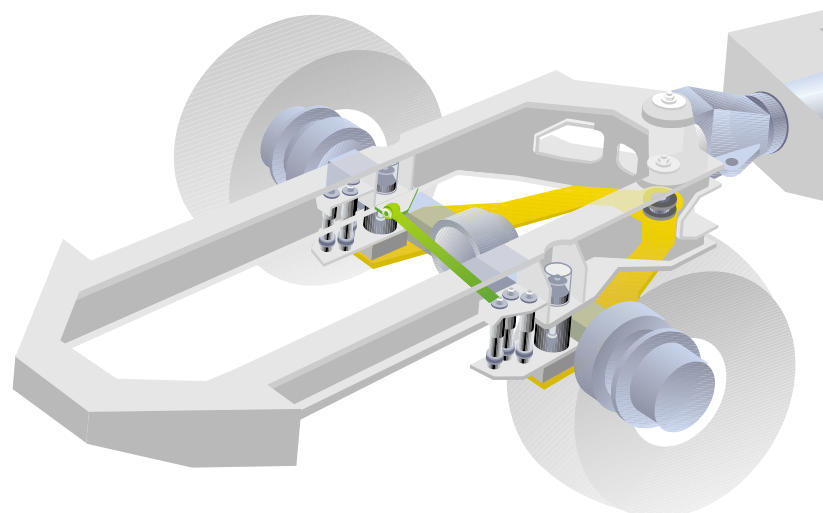

Drive on all wheels and 100% diff-locks

All Volvo articulated haulers have the option of drive on all wheels and diff-locks, longitudinal and transverse. For each situation, the operator can choose the most suitable drive combination, the number of driving wheels and locked or open differentials. A skilled operator always uses the smallest number of drive wheels and has as few diff-locks as possible engaged to extend the life of the tires and keep fuel consumption down. At the same time, effective diff-locks (100% lock-up) are available for use in difficult conditions.

The three-axle articulated haulers allow five drive combinations:

1. 6 x 4 without diff-locks is most economical under good driving conditions.
2. 6 x 4 with transverse diff-lock on the front axle improves tractive force without reducing steering capacity on slippery surfaces.

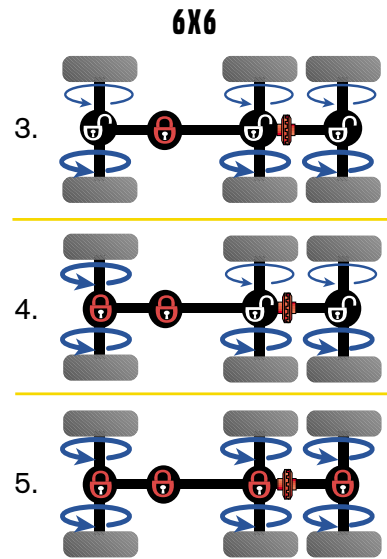
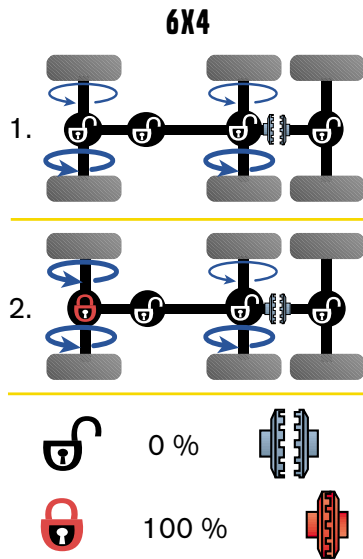

3. 6 x 6 with longitudinal diff-lock further enhances off-road mobility, and the hauler is still easy to steer.
4. 6 x 6 with longitudinal diff-lock and transverse diff-lock on the front axle makes it easier to steer up out of deep ruts to get better traction under the wheels.

5. 6 x 6 with all diff-locks engaged offers maximum off-road mobility, and the hauler can negotiate almost any kind of terrain.

Automatic transmission

Studies have shown that an operator in an articulated hauler with manual power shift changes gear 150–180 times per hour! The advantages of automatic transmission are therefore pretty obvious. For optimum utilization of engine power, the automatic transmission has torque converter lock-up in all gears.

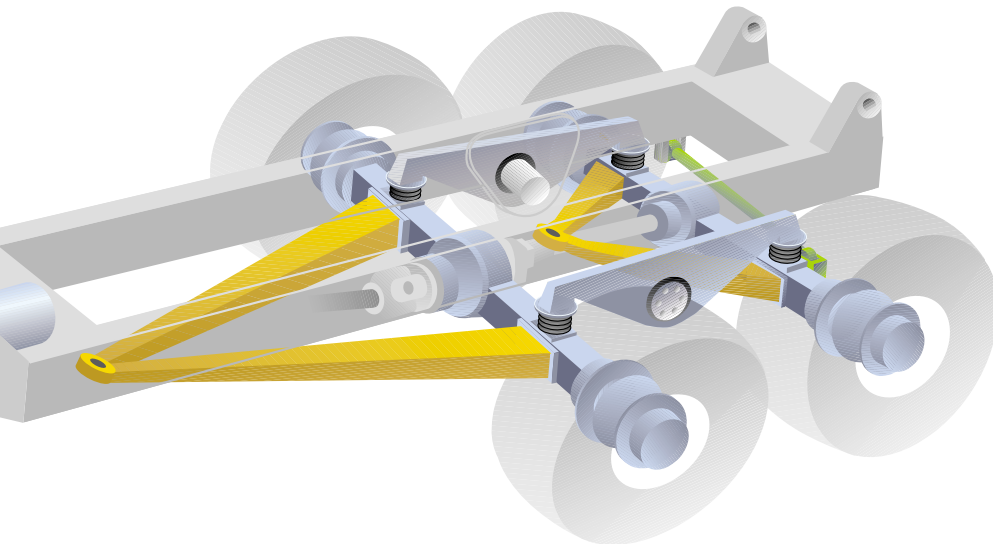

Simple maintenance, qualified service

Volvo's articulated haulers are very reliable with a minimum need of maintenance. Serviceability is built in from the start and the operator has access to detailed instructions – the daily checkup routine includes only 6–8 lube points. The engine hood opens to a 90 degree angle, the radiator can be swung out and the belly plates can be opened. These are details that make maintenance simple – an important reason for the hauler's high reliability.

To each according to its needs

Preventive maintenance is tailored to each hauler's needs. Type of work, working environment, operating hours, etc., are factors that determine the program drawn up by Volvo and the hauler owner. Together with Volvo Genuine spare parts and replacement components, preventive maintenance is the best guarantee of maximum availability and safety.

Reliable information – Contronic

Contronic is an electronic monitoring system which continuously monitors all the machine's main functions. Connected to the central warning system, Contronic immediately informs the operator of any malfunctions. The information is shown in plain text on a display and fault messages are supplemented with a flashing warning lamp.

Contronic also provides advance reminders of periodic services and makes quick and exact diagnoses of any problems. Such information makes it possible to minimize down-time and increase availability.

Data stored by Contronic comprises an important source of information for the service personnel and helps them to identify and remedy faults quickly.

5,000 mechanics per year

Another mechanic is trained by Volvo's global network of service schools every other hour, 24 hours a day, 365 days a year. All of Volvo's markets have a sufficiently high level of service preparedness to meet the needs on that market. Genuine spare parts are available thanks to advanced systems of

information management and material control. All to squeeze the most possible production out of every hauler.

PROSIS – all the information the mechanic needs

PROSIS is Volvo Construction Equipment's system for service information stored on CD-ROM. All the service literature, all the spare parts lists needed for Volvo's articulated haulers are on two CDs. With his portable PC, the serviceman in the field can immediately get all the information he needs. And with updates at least four times a year, the information is always correct and up-to-date.



The Volvo range

The C-series

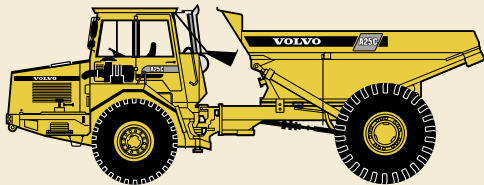

A25C 4x4

Payload	25 sh tn
Load capacity heaped	17.0 yd ³
Gross weight	84370 lb
Max speed	32 mph

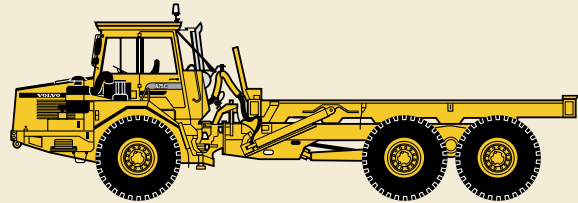

A25C Container

Payload	25 sh tn
Gross weight	88779 lb
Max speed	32 mph

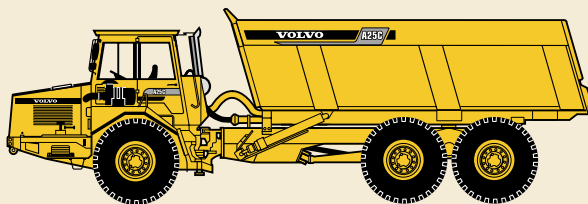

A25C Light Material

Payload	25 sh tn
Load capacity struck	31.0 yd ³
Gross weight	88779 lb
Max speed	32 mph

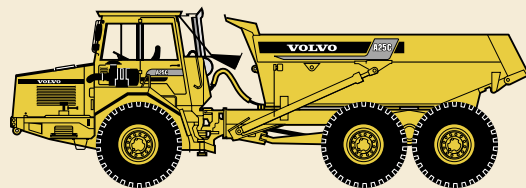

A25C 6x6

Payload	25 sh tn
Load capacity heaped	17.0 yd m ³
Gross weight	88779 lb
Max speed	32 mph

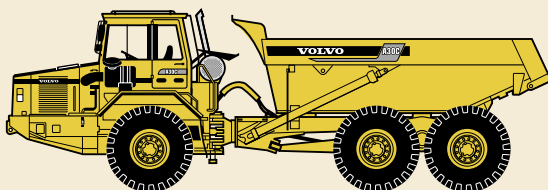

A30C 6x6

Payload	20 sh tn
Load capacity heaped	21.6 yd ³
Gross weight	106923 lb
Max speed	32 mph

The D-series

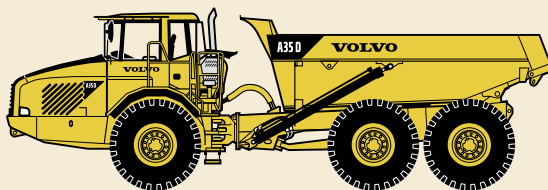

A35D 6x6

Payload	36 sh tn
Load capacity heaped	26.0 yd ³
Gross weight	134038 lb
Max speed	35 mph

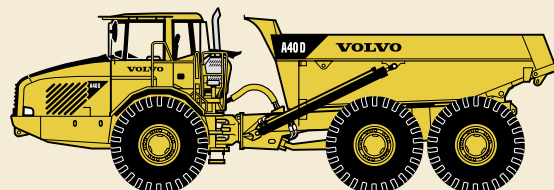

A40D 6x6

Payload	41 sh tn
Load capacity heaped	29.4 yd m ³
Gross weight	150507 lb
Max speed	34 mph



Technology on Human Terms

Volvo Construction Equipment is one of the world's leading manufacturers of construction machines, with a product range encompassing wheel loaders, excavators, articulated haulers, motor graders and more.

The tasks they face vary considerably, but they all share one vital feature: technology which helps man to perform better: safely, efficiently and with care of the environment. We refer to it as Technology on Human Terms.

The sheer width of the product range means it is always possible to choose exactly the right machine and attachment for the job. Each machine also comes with the quality, continuity and security which is represented by the

Volvo name. The strength of the service and parts organizations; the security of always having immediate access to leading-edge research and technical development are part of the Volvo name. A machine from Volvo meets the very highest demands in all kinds of jobs, under all conditions, the world over.

Volvo Construction Equipment develops, manufactures and markets construction equipment. We are a Volvo company with production facilities on four continents and a market presence in over 100 countries.

All products are not available in all markets. Under our policy of continuous improvement, we reserve the right to change specifications and designs without prior notice. The illustrations do not necessarily show the standard version of the machine.

VOLVO

**Volvo Construction Equipment
North America, Inc.**

One Volvo Drive, Asheville, NC
www.VolvoCE.com

Ref. No. 22 4 669 4096
Printed in Sweden 2001.05-5

Courtesy of Machine.Market