

VOLVO ARTICULATED HAULER

A25D/A30D

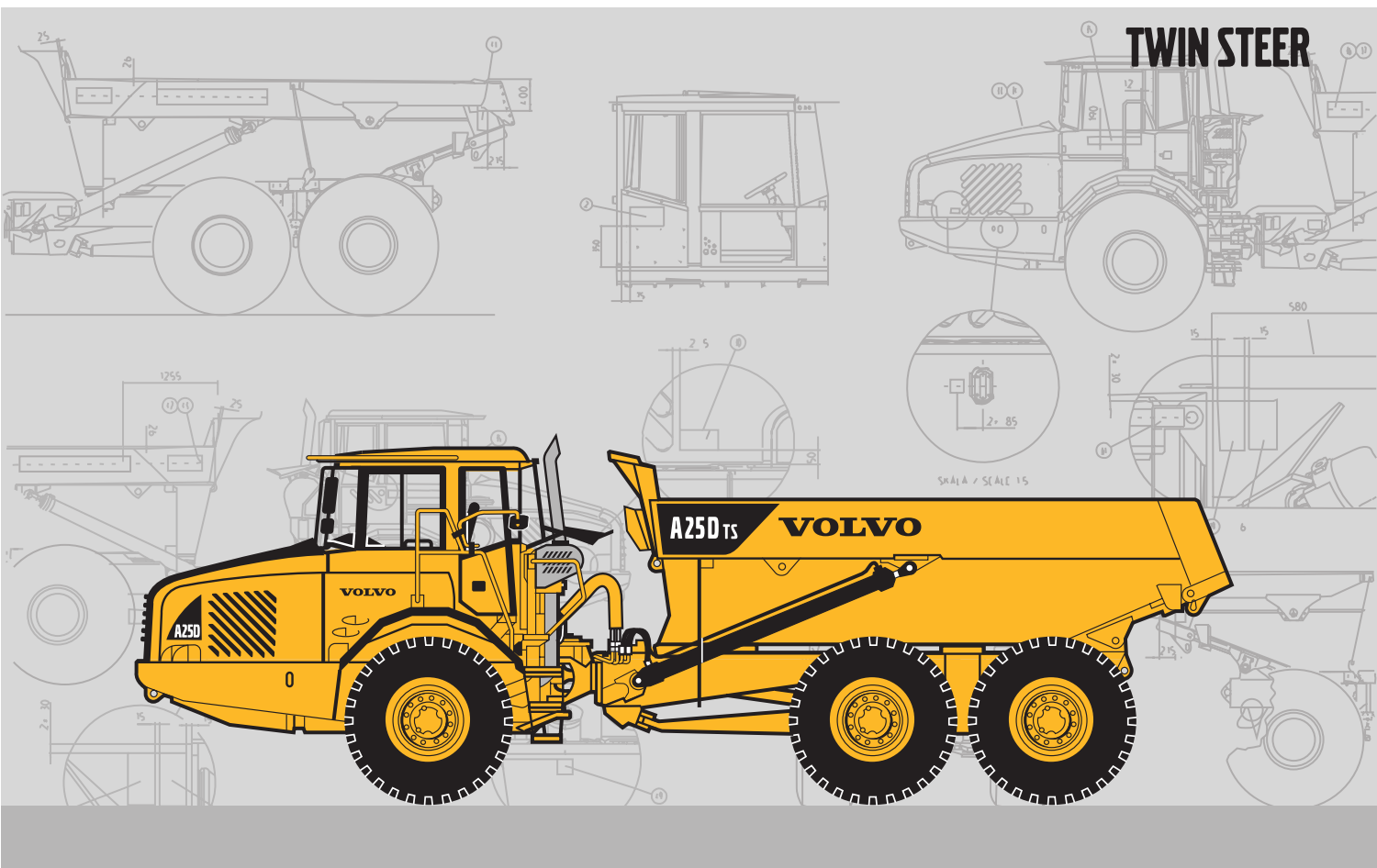

• **Engine output:**

A25D:

SAE J1995, Gross 228 kW (310 hp)

SAE J1349, Net 227 kW (309 hp)

A30D:

SAE J1995, Gross 242 kW (329 hp)

SAE J1349, Net 241 kW (328 hp)

• **Body volume, heaped:**

A25D: 15,0 m³

A30D: 17,5 m³

• **Load capacity:**

A25D: 24,0 t

A30D: 28,0 t

• **Volvo cab**, designed for high operator visibility, ergonomics and comfort.

• **Reduced maintenance time**, no daily or weekly grease points.

• **Electronic Operator's Communication System**

• **Volvo high performance – low emission** electronically controlled, direct injected, turbocharged, intercooled diesel engine.

• **Fully automatic planetary transmission**, electronically controlled.

• **Hydraulic retarder** integral in transmission.

• **Dropbox with longitudinal differential lock**

• **100% lock-up differentials.** One longitudinal and three transverse differential locks.

• **Front axle with three-point suspension.**

• **Volvo terrain bogie**, individually oscillating axles and high ground clearance.

• **Volvo Load & Dump Brake.**

VOLVO

The A25D - A30D Twin Steer in detail

Service

The computerized information system monitors all fluid levels, minimizing daily and weekly service times.

Time to next service and the status of vital vehicle systems is shown to the operator on a display in the instrument panel.

Service accessibility: Fold-down front grill with access ladder to remote filter bank, located in front of engine.

Large, 90° opening hood for total engine access.

Remote drain hoses and swing-out radiator for easy cleaning.

Fill capacities

Crankcase.....	38 l
Fuel tank	400 l
Cooling system	71 l
Transmission total	41 l
Dropbox.....	8,5 l
Axles, front/ rear	33 l
First bogie axle.....	34 l
Hydraulic tank	175 l

Engine

Volvo inline 6-cylinder, direct injected electronically controlled, turbocharged, intercooled 4-stroke low-emission diesel engine with wet replaceable cylinder liners.

Fan: Hydrostatically driven, thermostatically controlled variable speed radiator fan consuming power only when needed.

Engine brake: Exhaust retarder.

A25D

Make, model	Volvo D10BACE2*
Make, model	Volvo D10BADE2**
Max power at	33,3 r/s (2 000 r/min)
SAE J1995 Gross	228 kW (310 hp)
Flywheel power at	33,3 r/s (2 000 r/min)
SAE J1349 Net, DIN 6271***	227 kW (309 hp)
Max torque at	22,5 r/s (1 350 r/min)
SAE J1995 Gross	1 375 Nm
SAE J1349 Net, DIN 6271***	1 365 Nm
Displacement total	9,6 l

With fan operating at full speed, the flywheel power is 214 kW (291 hp) and maximum torque is 1 276 Nm which corresponds to DIN 70020.

A30D

Make, model	Volvo D10BAE2*
Make, model	Volvo D10BABE2**
Max power at	33,3 r/s (2 000 r/min)
SAE J1995 Gross	242 kW (329 hp)
Flywheel power at	33,3 r/s (2 000 r/min)
SAE J1349 Net, DIN 6271***	241 kW (328 hp)
Max torque at	22,5 r/s (1 350 r/min)
SAE J1995 Gross	1 420 Nm
SAE J1349 Net, DIN 6271***	1 410 Nm
Displacement total	9,6 l

With fan operating at full speed, the flywheel power is 228 kW (310 hp) and maximum torque is 1 321 Nm which corresponds to DIN 70020.

*) Meets US (EPA) step 2, California (CARB) step 2 and Europe (EU) step 2.

**) Meets Europe (EU) step 2.

**) with fan at normal speed.



Electrical system

All cables, sockets and pins are identified.

Cables are enclosed in plastic conduits and secured to main frame.

Halogen lights. Prewired for options.

Connectors meet IP67 standard for water-proofing as necessary.

Voltage	24 V
Battery capacity	2x170 Ah
Alternator.....	1,54 kW (55 A)
Starter motor.....	6,6 kW (9 hp)

Drivetrain

Volvo components, specifically designed for hauler applications.

Torque converter: Single-stage with free-wheeling stator and automatic lock-up on all gears.

Transmission: Fully automatic planetary transmission with six forward gears and two reverse gears, with a built-in variable hydraulic retarder.

Dropbox: Volvo design, single-stage.

Axles: Volvo design with fully floating axle shafts and planetary type hub reductions.

Differential locks: One longitudinal and three transverse with 100% lock-up function, operator selectable on the move.

Configuration: 6x4 or 6x6 drive, operator selectable on the move.

	A25D	A30D
Torque converter.....	2,37:1	2,37:1
Transmission, Volvo	PT 1560	PT 1560
Dropbox.....	IL 1	IL 1
Axles, Volvo	AH 56	AH 64

Speed:

Forward	
1	8 km/h
2	12 km/h
3	22 km/h
4	31 km/h
5	40 km/h
6	53 km/h
Reverse	
1	8 km/h
2	13 km/h

Brake system

Dual circuit system with air-hydraulic disc brakes. Meets ISO 3450 and SAE J1473 at total machine weight.

Service brakes: Dry discs on all wheels.

Circuit division: One circuit for front axle and one for bogie axles.

Parking brake: Spring-applied disc brake on the propeller shaft, designed to hold a loaded machine on a grade up to 18%. When the parking brake is applied, the longitudinal differential is locked.

Compressor: Gear-driven by engine transmission.

Retarder: Hydraulic, infinitely variable, integrated in transmission. Total retarding capability including transmission retarder and exhaust retarder, see graph.

Steering system with double command: Hydromechanical self-compensating articulated steering for safe and accurate high-speed hauling. Fast acting, low effort steering with 3,4 turns lock-to-lock for slow speed maneuverability.

The double command makes it possible to turn around the operator's seat and operate the machine in reverse with an extra set of pedals and steering wheel.

Comfort Drive Control for operating in reverse is available as optional equipment.

Cylinders: Two double-acting steering cylinders.

Secondary steering: Meets ISO 5010 at total machine weight.

Steering angle: ±45°

Weights			Ground Pressure				Load Capacity			
Operating weight includes all fluids and operator.			At 15% sinkage of unloaded radius and specified weights.				Body volume according to SAE 2:1.			
	A25D	A30D		A25D	A30D			A25D	A30D	
Tires	23.5R25	750/65R25	Tires	23.5R25	750/65R25	23.5R25				
Operating weight unloaded			Unloaded			Std. Body				
Front	12 160 kg	12 500 kg	Front	123 kPa	101 kPa	127 kPa	Load capacity	24 000 kg	28 000 kg	
Rear	9 400 kg	10 560 kg	Rear	48 kPa	43 kPa	54 kPa	Body, struck	11,7 m ³	13,6 m ³	
Total	21 560 kg	23 060 kg	Loaded			Body, heaped			15,0 m ³	17,5 m ³
Payload	24 000 kg	28 000 kg	Front	144 kPa	121 kPa	152 kPa	With underhung tailgate			
Total weight			Rear	159 kPa	146 kPa	183 kPa	Body, struck	12,0 m ³	13,8 m ³	
Front	14 140 kg	14 990 kg					Body, heaped	15,3 m ³	18,0 m ³	
Rear	31 420 kg	36 070 kg					With overhung tailgate			
Total	45 560 kg	51 060 kg					Body, struck	12,1 m ³	14,0 m ³	
							Body, heaped	15,6 m ³	18,1 m ³	
							With over and under hung tailgate			
							Body, struck	12,1 m ³	--	
							Body, heaped	15,6 m ³	--	

Suspension

Volvo's unique maintenance-free 3-point suspension system. The axles are suspended at three points, which results in independent movement needed in rough terrain.

Front axle: One hollow rubber spring on each side. A cross stay provides the stability. Two shock absorbers on each side.

Bogie: Volvo's unique terrain bogie permits long suspension travel and independent wheel movement, keeps the body level, retaining the load.

Cab

Volvo cab, ergonomically designed for high operator comfort and excellent visibility. Wide threshold-free door opening and ergonomic cab entrance. Insulating rubber pads to reduce vibrations. Tilt/ telescopic steering wheel. Overhead console for radio and storage. Dash-mounted Operator's Communication System. Storage bins.

Standard: ROPS/FOPS tested and approved. (ISO 3471, SAE J1040) / (ISO 3449, SAE J231) standards.

Heater and defroster: Filtered fresh air, four-speed fan and pressurized cab to maintain a clean operating environment. Multi-level air outlets and separate defroster vents for all windows.

Operator's seat: Adjustable operator's seat with flameproof upholstery. Retractable seat belt. Sound level in cab, ISO 6396 74 dB (A)

Hydraulic system

Load-sensing, variable displacement, piston pumps, consume power only when needed.

Pumps: Four engine-driven variable displacement load-sensing piston pumps driven by the flywheel PTO. One ground-dependent piston pump for secondary steering mounted on the dropbox.

Filter: One fibreglass filter with magnetic core.

Pump capacity per pump:

Engine-dependent..... 140 l/min
Ground-dependent 142 l/min
at shaft speed 52,5 r/s (3 150 r/min)
Working pressure 25 MPa

Body

Load and dump brake: With the engine running, the service brakes on bogie axles are applied and transmission is shifted to neutral.

Body material: Hardened and tempered steel body, flat plate design made of high-strength steel.

Front..... 8 mm
Sides..... 12 mm
Bottom..... 14 mm
Chute..... 14 mm
Yield strength 900 N/mm²
Tensile strength..... 1 250 N/mm²
Hardness min 360 HB

Dump Cylinders: Two single-stage double-acting cylinders.

A25D A30D

Tipping angle..... 74°..... 70°
Tipping time with load 12 s..... 12 s
Lowering time 9 s..... 9 s

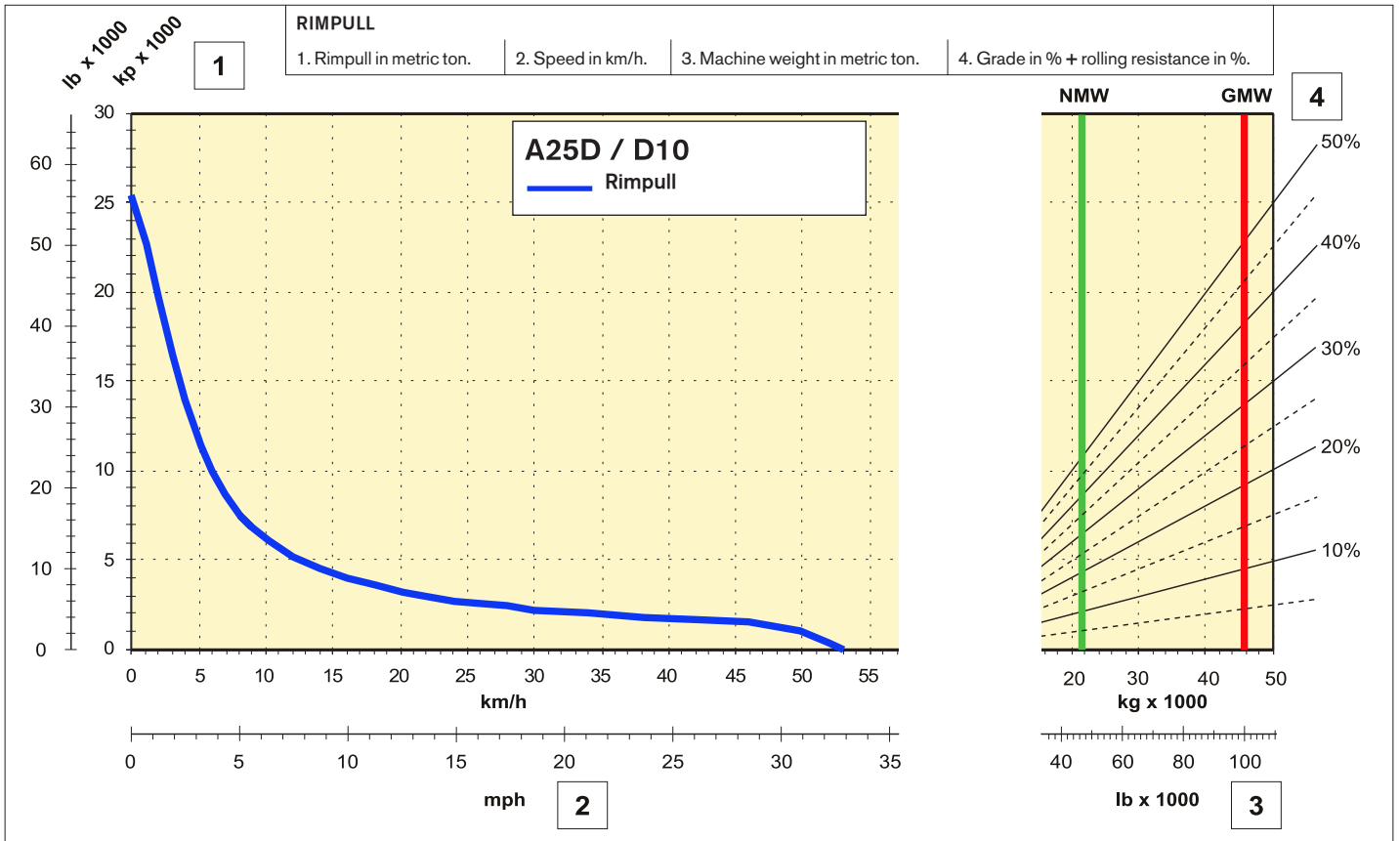

Instructions

Diagonal lines represent total resistance (grade % ± rolling resistance %). Charts based on 0% rolling resistance, standard tires and gearing, unless otherwise stated.

- A. Find the diagonal line with the appropriate total resistance on the right-hand edge of the chart.
- B. Follow the diagonal line downward until it intersects the actual machine weight line, NMW or GMW.
- C. Draw a new line horizontally to the left from the point of intersection until the new line intersects the rimpull or retardation curve.
- D. Read down for vehicle speed.

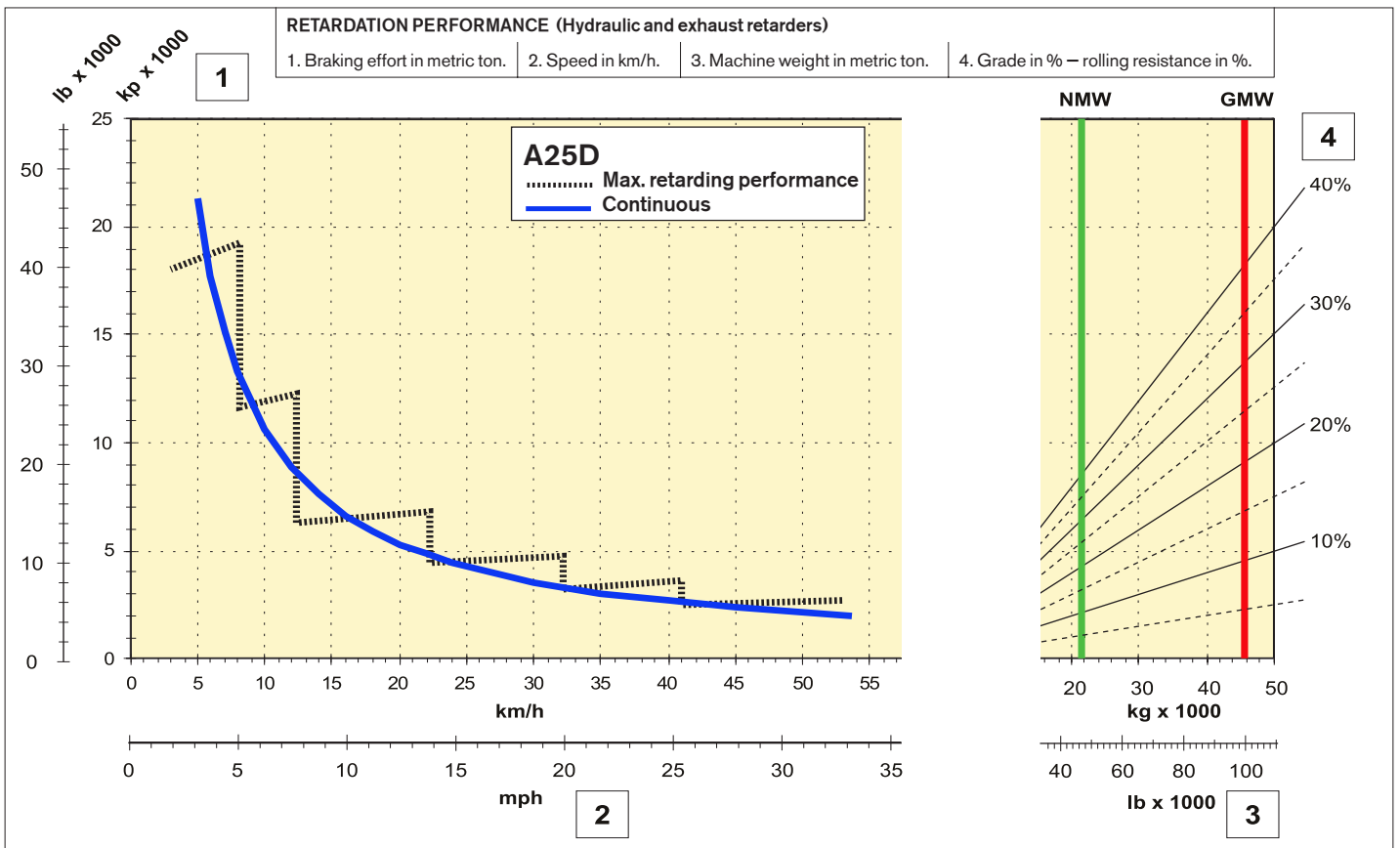

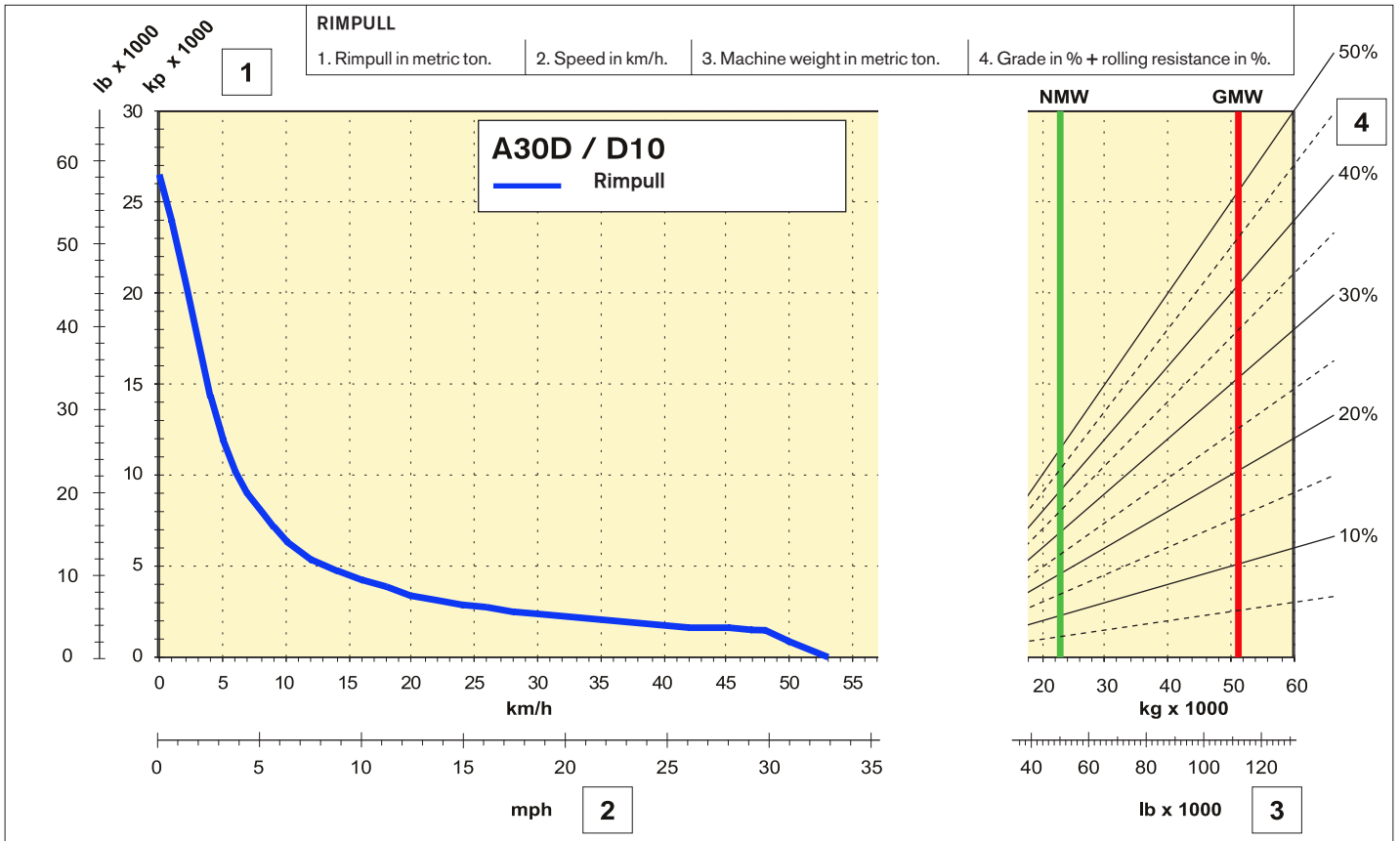

Instructions

Diagonal lines represent total resistance (grade % ± rolling resistance %). Charts based on 0% rolling resistance, standard tires and gearing, unless otherwise stated.

- Find the diagonal line with the appropriate total resistance on the right-hand edge of the chart.
- Follow the diagonal line downward until it intersects the actual machine weight line, NMW or GMW.
- Draw a new line horizontally to the left from the point of intersection until the new line intersects the rimpull or retardation curve.
- Read down for vehicle speed.

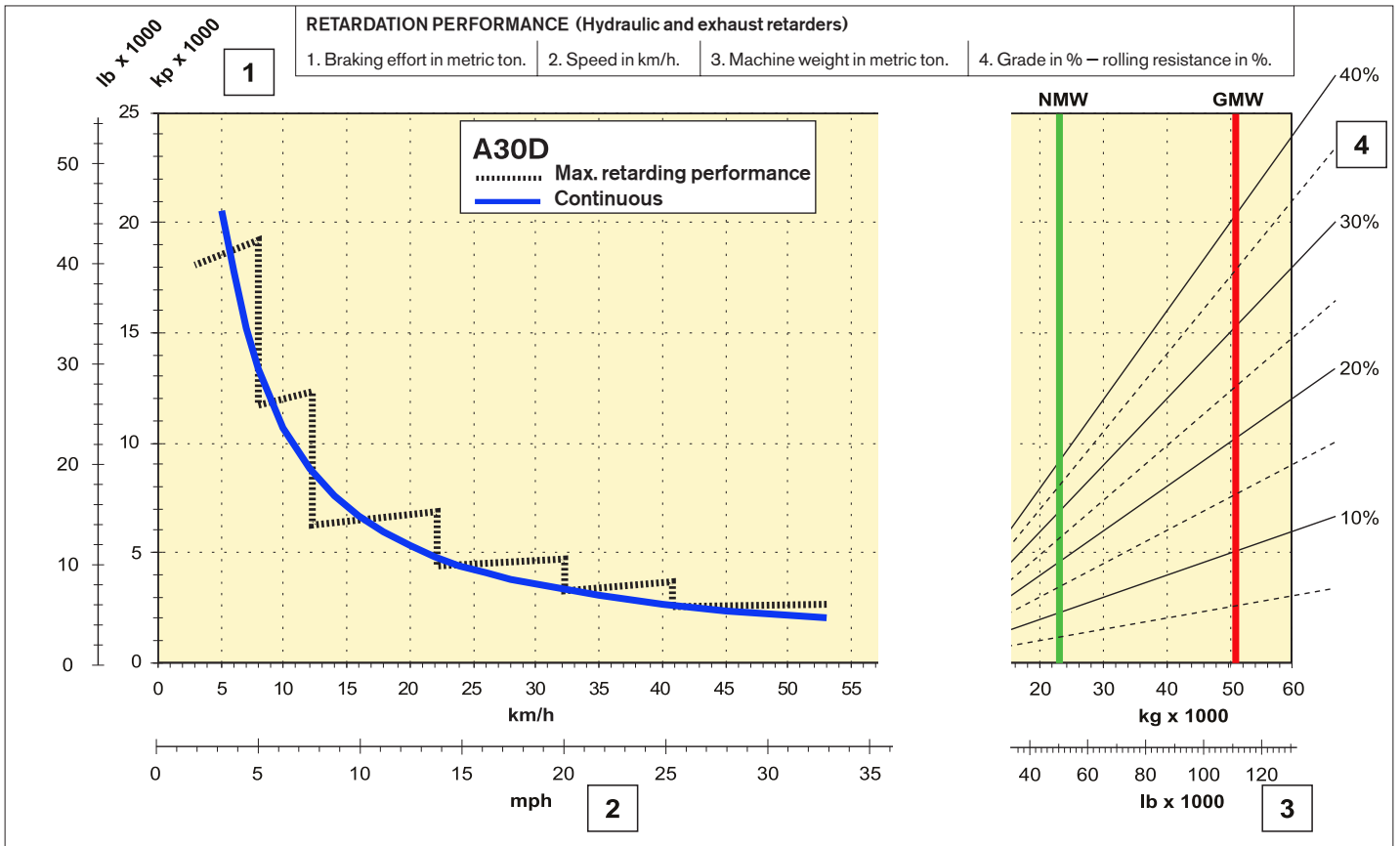

Specifications A25D - A30D Twin Steer

Pos	Metric (mm)		Imperial (feet)	
	A25D	A30D	A25D	A30D
A	10 220	10 297	33'6"	33'9"
A ₁	4 954	4 954	16'3"	16'3"
A ₂	5 764	6 002	18'11"	19'8"
B	5 152	5 339	16'11"	17'6"
C	3 428	3 428	11'3"	11'3"
C ₁	3 318	3 318	10'11"	10'11"
C ₂	1 768	1 768	5'10"	5'10"
C ₃	3 760	3 834	12'4"	12'7"
D	2 764	2 764	9'1"	9'1"
E	1 210	1 210	4'0"	4'0"
F	4 175	4 175	13'8"	13'8"
G	1 670	1 670	5'6"	5'6"
H	1 610	1 688	5'3"	5'6"
I	608	608	2'0"	2'0"
J	2 778	2 856	9'1"	9'4"
K	2 102	2 181	6'11"	7'2"
L	677	686	2'3"	2'3"
M	6 559	6 592	21'6"	21'8"
N	8 105	8 105	26'7"	26'7"
N ₁	4 079	4 037	13'5"	13'3"
O	2 700	2 900	8'10"	9'6"
P	2 490	2 706	8'2"	8'11"
R	512	513	1'8"	1'8"
R ₁	634	635	2'1"	2'1"
U	3 257	3 310	10'8"	10'10"
V	2 258	2 216	7'5"	7'3"
V*	-----	2 258	-----	7'5"
W	2 859	2 941	9'5"	9'8"
W*	-----	2 859	-----	9'5"
X	456	456	1'6"	1'6"
X ₁	581	582	1'11"	1'11"
X ₂	659	659	2'2"	2'2"
Y	2 258	2 216	7'5"	7'3"
Y*	-----	2 258	-----	7'5"
Z	2 859	2 941	9'5"	9'8"
Z*	-----	2 859	-----	9'5"
a ₁	23,5°	23,5°	23,5°	23,5°
a ₂	74°	70°	74°	70°
a ₃	45°	45°	45°	45°

A25D: Unloaded machine with 23,5R25
A30D: Unloaded machine with 750/65R25
* A30D with optional 23,5R25 tires

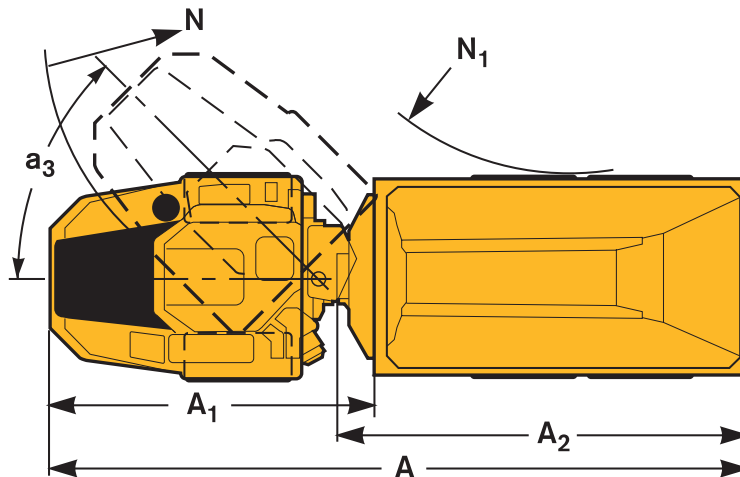
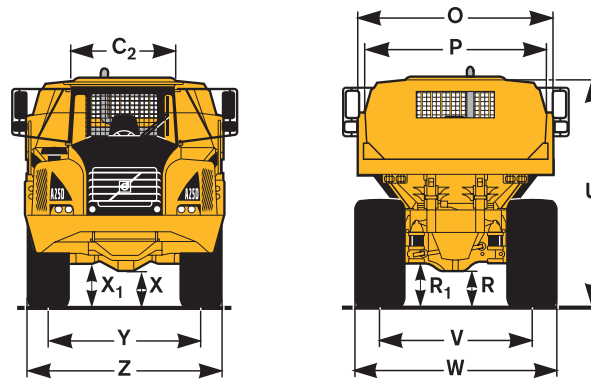
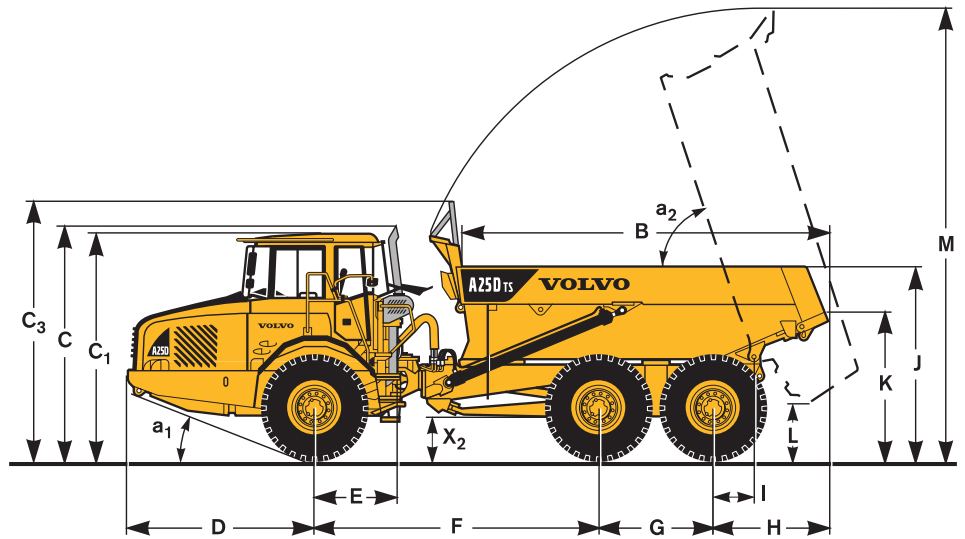

STANDARD EQUIPMENT

Safety

ROPS/ FOPS protected cab
Service platform for ease of service
Anti-slip material on hood and fenders
Hazard lights
Horn
Protective grille for rear window
Rear-view mirrors, forward and reverse
Secondary steering
Retractable 3-inch safety belt
Steering joint locking assembly
Dump body lock
Windshield wipers and washers for front wind-
shield and rear window
Exhaust pipe moved for reverse travelling

Comfort

Two adjustable steering wheels for operation in
both directions
Throttle pedal for reverse travelling
Brake pedal for reverse travelling
Cab heater with filtered fresh air and defroster
Overhead console for radio and storage
Sun visor
Tinted glass
Can holder /storage tray
Cigarette lighter
Ashtray
Space for lunch cooler
Storage box
Reversible operator's seat for operation in both
directions

Engine

Direct injected, electronically controlled
Turbocharged, intercooled
Remote oil drain plug
Remote oil filters, for ease of access
Preheater for easier cold starts

Electrical system

55 A alternator
Battery disconnect switch
Extra 24 V socket for lunch cooler

Lights:

- Headlights
- Parking lights
- Direction indicators
- Rear lights
- Back-up lights
- Extra back-up lights
- Work lights, rear-facing, mounted on mudguard
- Rotating beacon mounted under load body
- Brake lights
- Cab lighting
- Instrument lighting

Operator information interface

Gauges:

- Speedometer
 - Tachometer
 - Brake pressure
 - Fuel
 - Transmission oil temperature
- Pilot lights for all switches
Warning lights grouped and easy to read
Central warning (3 levels) for all vital functions
Extra Central warning light, visible during reverse
operation
Central positioned information display:
- Automatic pre-start checks
 - Operation information, easy-to-find menu
 - Troubleshooting diagnostics
 - Hour meter
 - Clock
 - Machine settings

Drivetrain

Automatic transmission
Torque converter with automatic lock-up
Dropbox, single-stage
6x4 or 6x6 operator selectable drive modes
Hydraulic variable retarder
100% longitudinal differential lock
100% differential locks in all axles

Brakes

Air-hydraulic disc brakes
Two circuit brake system
Parking brake on prop shaft

Body

Body prepared for exhaust heating
Load and Dump brake
Sight hole with protective grille in load body

Tires

A25D: 23,5R25
A30D: 750/65R25

Other

Air drier

(* Special Standard Equipment)

OPTIONAL EQUIPMENT

Safety

Fire-extinguisher and first aid kit
Secondary steering for reverse operation

Service and maintenance

Tool kit with tire inflation unit
Electrical hood opening

Engine

Extra air cleaner, heavy-duty
Extra air cleaner, oil bath type
External emergency engine stop
Delayed engine stop
Electric engine heater (120V or 240V)
Engine and cab heater, diesel **
Fuel filter heater, electrical, 24V **
Fast fuel filling system **

Electrical

Work lights, roof-mounted
Work lights, rear-facing, fender-mounted
Work lights (distance lights) on cab roof **
Rotating beacon, collapsible mount
Rotating beacon, extra
Back-up alarm
Rear vision system, monitor located by rear
window, improves visibility for reverse operation
Anti-theft system (prevents engine start)
Headlights for left-hand traffic
Alternator, heavy-duty 80 A
Battery charger **
Jump start connection, NATO **
Back up light, extra **
Cab heater, electrical **

Cab

Air suspended, electrically heated operator's seat
Seat cover **
Armrests prepared for joysticks **
Instructor seat with seat belt
Electrically heated rear-view mirrors
Air conditioning
Radio installation kit
Radio
Cable kit for cab heater (120V or 240V)
Window tint film
Comfort Drive Control for reverse operation
Vandalism protection for cab windows **
Rear-view mirror, close up **
Lowered cab roof
Roof rack **

Body

Body exhaust heating kit

A25D
Underhung tailgate, link operated
Overhung tailgate, link operated (only in combina-
tion with underhung gate)
Overhung tailgate, wire operated

A30D
Underhung tailgate, link operated
Overhung tailgate, wire operated

Wear plates
Extra front spillguard
Upper side extension, 200 mm

Attachments

Light Material body (0,9 t/m³) **
Flat loading platform without dumping function **

Tires

A25D: 650/65 R25
A30D: 23,5R25

External

Rear mudflaps
Belly plates for trailer A-stay **
Increased bogie axle distance, 50mm **
Additional front bumper (rubber)

Other

Synthetic hydraulic oil (biologically degradable)
Arctic oil kit
Toolbox
Non-skid chain modification, front unit **
Non-skid chain storing hooks **

(* * Special Optional Equipment)

Under our policy of continual product improvement, we reserve the right to change specifications and design without prior notice. The illustrations do not necessarily show the standard version of the machine.

VOLVO

Construction Equipment

Ref. No 21 2 669 4160 English
Sweden 2002-04 ART
Volvo Växjö