

VOLVO ARTICULATED HAULER

A25D/A30D

LIGHT MATERIAL

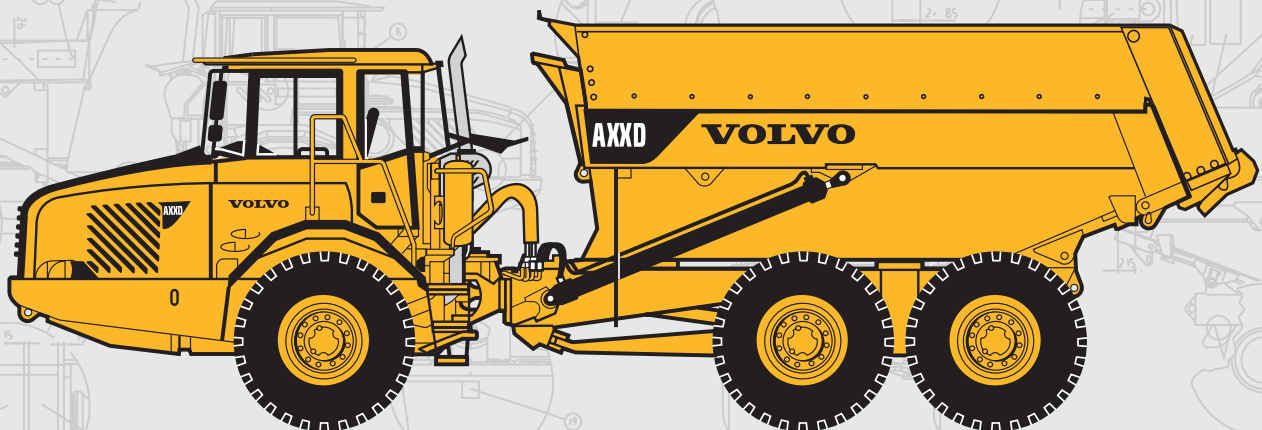

- **Engine output:**
A25D s/n 13001-
SAE J1995, Gross 224 kW (305 hp)
SAE J1349, Net 223 kW (303 hp)
A30D s/n 12001-
SAE J1995, Gross 252 kW (343 hp)
SAE J1349, Net 251 kW (341 hp)
- **Body volume, heaped:**
A25D: 26,2 m³
A30D: 30,6 m³
- **Load capacity:**
A25D: 24,0 t
A30D: 28,0 t
- **Volvo cab**, designed for high operator visibility, ergonomics and comfort.
- **Reduced maintenance time**, no daily or weekly grease points.
- **Electronic Operator's Communication System**
- **Volvo high performance – low emission**, electronically controlled direct injected, turbocharged, intercooled diesel engine.
- **Fully automatic planetary transmission**, electronically controlled.
- **Hydraulic retarder** integral in transmission.
- **Dropbox with longitudinal differential lock**
- **100% lock-up differentials.** One longitudinal and three transverse differential locks.
- **Front axle with three-point suspension.**
- **Volvo terrain bogie**, individually oscillating axles and high ground clearance.
- **Light material body**, for material density 0,9 t/m³
- **Volvo Load & Dump Brake.**

VOLVO

The A25D - A30D Light Material

Service

The computerized information system monitors all fluid levels, minimizing daily and weekly service times.

Time to next service and the status of vital vehicle systems is shown to the operator on a display in the instrument panel.

Service accessibility: Fold-down front grill with access ladder to remote filter bank, located in front of engine.

Large, 90° opening hood for total engine access.

Remote drain hoses and swing-out radiator for easy cleaning.

Fill capacities

Crankcase.....	40 l
Fuel tank.....	400 l
Cooling system	115 l
Transmission total	41 l
Dropbox.....	8,5 l
Axles, front/ rear.....	33 l
First bogie axle.....	34 l
Hydraulic tank.....	175 l

Engine

Volvo inline 6-cylinder, direct injected electronically controlled, turbocharged, intercooled 4-stroke low-emission diesel engine with wet replaceable cylinder liners.

Fan: Hydrostatically driven, thermostatically controlled variable speed radiator fan consuming power only when needed.

Engine brake: Exhaust retarder.

A25D

Make, model	Volvo D9AAAE2*
Make, model	Volvo D9AABE2**
Max power at	35 r/s (2 100 r/min)
SAE J1995 Gross	224 kW (305 hp)
Flywheel power at	35 r/s (2 100 r/min)
SAE J1349 Net, DIN 6271***	223 kW (303 hp)
Max torque at	20 r/s (1 200 r/min)
SAE J1995 Gross	1 700 Nm
SAE J1349 Net, DIN 6271***	1 689 Nm
Displacement total	9,4 l

With fan operating at full speed, the flywheel power is 210 kW (285 hp) and maximum torque is 1 589 Nm which corresponds to DIN 70020.

A30D

Make, model	Volvo D9AAAE2*
Make, model	Volvo D9AAAE2**
Max power at	31,7 r/s (1 900 r/min)
SAE J1995 Gross	252 kW (343 hp)
Flywheel power at	31,7 r/s (1 900 r/min)
SAE J1349 Net, DIN 6271***	251 kW (341 hp)
Max torque at	20 r/s (1 200 r/min)
SAE J1995 Gross	1 700 Nm
SAE J1349 Net, DIN 6271***	1 689 Nm
Displacement total	9,4 l

With fan operating at full speed, the flywheel power is 238 kW (324 hp) and maximum torque is 1 589 Nm which corresponds to DIN 70020.

*) Meets Europe (EU) step 2.

**) Meets US (EPA) step 2, California (CARB) step 2 and Europe (EU) step 2.

**) with fan at normal speed.

Electrical system

All cables, sockets and pins are identified. Cables are enclosed in plastic conduits and secured to main frame.

Halogen lights. Prewired for options.

Connectors meet IP67 standard for waterproofing as necessary.

Voltage	24 V
Battery capacity	2x170 Ah
Alternator	2,24 kW (80 A)
Starter motor	7 kW (9,4 hp)

Drivetrain

Volvo components, specifically designed for hauler applications.

Torque converter: Single-stage with free-wheeling stator and automatic lock-up on all gears.

Transmission: Fully automatic planetary transmission with six forward gears and two reverse gears, with a built-in variable hydraulic retarder.

Dropbox: Volvo design, single-stage.

Axles: Volvo design with fully floating axle shafts and planetary type hub reductions.

Differential locks: One longitudinal and three transverse with 100% lock-up function, operator selectable on the move.

Configuration: 6x4 or 6x6 drive, operator selectable on the move.

	A25D	A30D
Torque converter.....	2,37:1	2,37:1
Transmission, Volvo	PT 1562	PT 1562
Dropbox.....	IL 1	IL 1
Axles, Volvo	AH 56	AH 64

Speed:

Forward	
1	8 km/h
2	12 km/h
3	22 km/h
4	31 km/h
5	40 km/h
6	53 km/h
Reverse	
1	8 km/h
2	13 km/h

Brake system

Dual circuit system with air-hydraulic disc brakes. Meets ISO 3450 and SAE J1473 at total machine weight.

Service brakes: Dry discs on all wheels.

Circuit division: One circuit for front axle and one for bogie axles.

Parking brake: Spring-applied disc brake on the propeller shaft, designed to hold a loaded machine on a grade up to 18%. When the parking brake is applied, the longitudinal differential is locked.

Compressor: Gear-driven by engine transmission.

Retarder: Hydraulic, infinitely variable, integrated in transmission.

Total retarding capability including transmission retarder and exhaust retarder, see graph.

Steering system

Hydromechanical self-compensating articulated steering for safe and accurate high-speed hauling. Fast acting, low effort steering with 3,4 turns lock-to-lock for slow speed maneuverability.

Cylinders: Two double-acting steering cylinders.

Secondary steering: Meets ISO 5010 at total machine weight.

Steering angle: ±45°

Suspension

Volvo's unique maintenance-free 3-point suspension system. The axles are suspended at three points, which results in independent movement needed in rough terrain.

Front axle: One hollow rubber spring on each side. A cross stay provides the stability. Two shock absorbers on each side.

Bogie: Volvo's unique terrain bogie permits long suspension travel and independent wheel movement, keeps the body level, retaining the load.

Cab

Volvo cab, ergonomically designed for high operator comfort and excellent visibility. Wide threshold-free door opening and ergonomic cab entrance. Insulating rubber pads to reduce vibrations. Tilt/ telescopic steering wheel. Overhead console for radio and storage. Dash-mounted Operator's Communication System. Storage bins.

Standard: ROPS/FOPS tested and approved. (ISO 3471, SAE J1040) / (ISO 3449, SAE J231) standards.

Heater and defroster: Filtered fresh air, four-speed fan and pressurized cab to maintain a clean operating environment. Multi-level air outlets and separate defroster vents for all windows.

Operator's seat: Adjustable operator's seat with flameproof upholstery. Retractable seat belt.

Sound level in cab, ISO 6396 74 dB (A)

Hydraulic system

Load-sensing variable displacement piston pumps consume power only when needed.

Pumps: Four engine-driven variable displacement load-sensing piston pumps driven by the flywheel PTO. One ground-dependent piston pump for secondary steering mounted on the dropbox.

Filter: One fibreglass filter with magnetic core.

Pump capacity per pump:

Engine-dependent	140 l/min
Ground-dependent	142 l/min
at shaft speed	52,5 r/s (3 150 r/min)
Working pressure.....	25 MPa

Weights			Ground Pressure				Load Capacity		
Operating weight includes all fluids and operator			At 15% sinkage of unloaded radius and specified weights.				Body volume according to SAE 2:1		
	A25D	A30D		A25D	A30D			A25D	A30D
Tires	23,5R25 650/65R25	750/65R25	Tires	23,5R25 650/65R25	750/65R25	23,5R25			
Operating weight unloaded			Unloaded			Std. Body			
Front	12 160 kg	12 500 kg	Front	123 kPa	101 kPa	127 kPa	Load capacity	24 000 kg	28 000 kg
Rear	9 400 kg	10 560 kg	Rear	48 kPa	43 kPa	54 kPa	Body, struck	22,5 m ³	26,6 m ³
Total	21 560 kg	23 060 kg	Loaded				Body, heaped	26,2 m ³	30,6 m ³
Payload	24 000 kg	28 000 kg	Front	144 kPa	121 kPa	152 kPa			
Total weight			Rear	159 kPa	146 kPa	183 kPa			
Front	14 140 kg	14 990 kg							
Rear	31 420 kg	36 070 kg							
Total	45 560 kg	51 060 kg							

Body

Light material body: Bolted body extensions extends the standard body for light material transport, material density 0,9 t/m³.

Load and dump brake: With the engine running, the service brakes on bogie axles are applied and transmission is shifted to neutral.

Body material: Hardened and tempered steel body, flat plate design made of high-strength steel.

- Front 8 mm
- Sides 12 mm
- Bottom 14 mm
- Chute 14 mm
- Yield strength 1 000 N/mm²
- Tensile strength 1 250 N/mm²
- Hardness 400 HB

Dump Cylinders: Two single-stage double-acting cylinders.

	A25D	A30D
Tipping angle.....	74°	70°
Tipping time with load.....	12 s	12 s
Lowering time.....	9 s	9 s

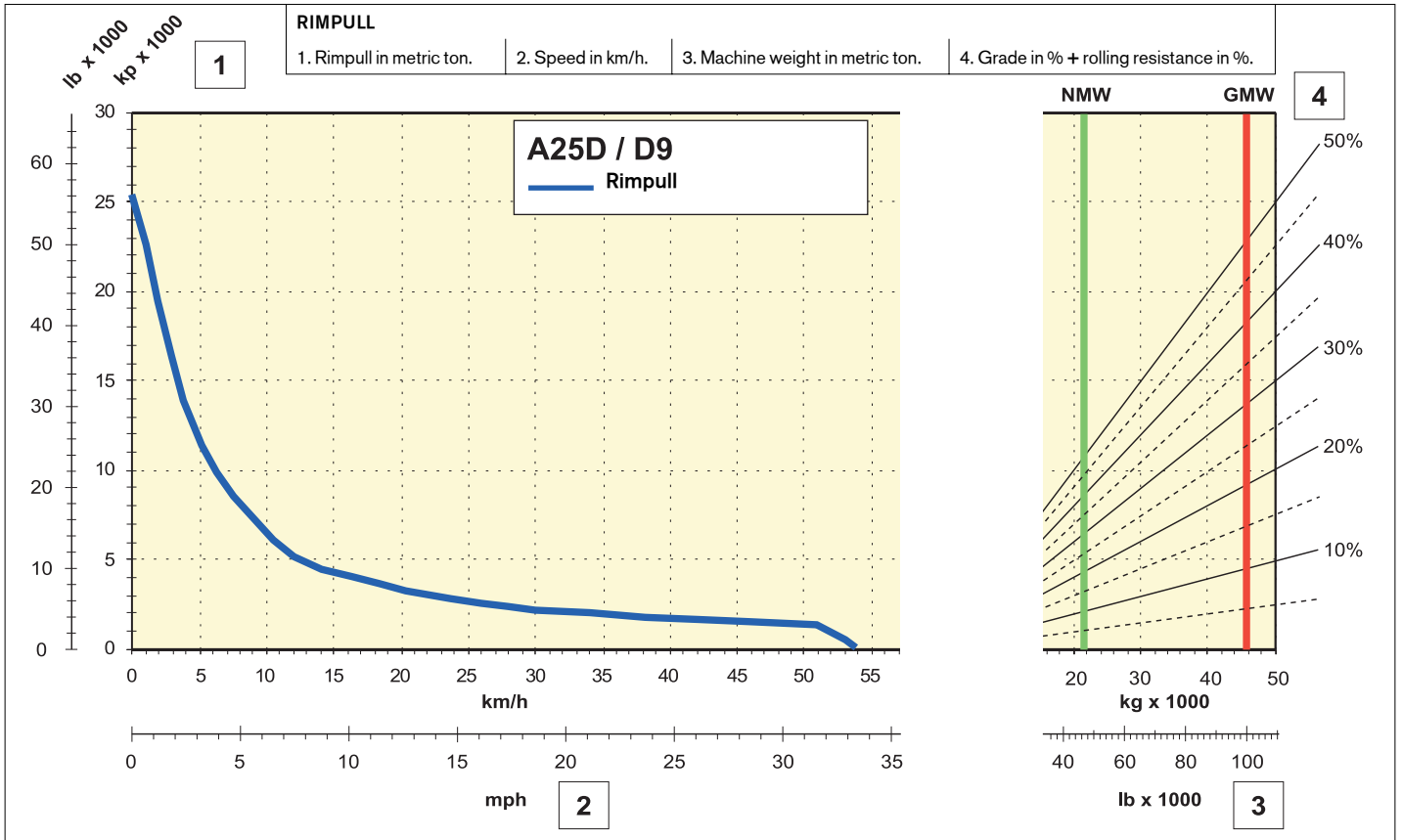

Instructions

Diagonal lines represent total resistance (grade % ± rolling resistance %). Charts based on 0% rolling resistance, standard tires and gearing, unless otherwise stated.

- A. Find the diagonal line with the appropriate total resistance on the right-hand edge of the chart.
- B. Follow the diagonal line downward until it intersects the actual machine weight line, NMW or GMW.
- C. Draw a new line horizontally to the left from the point of intersection until the new line intersects the rimpull or retardation curve.
- D. Read down for vehicle speed.

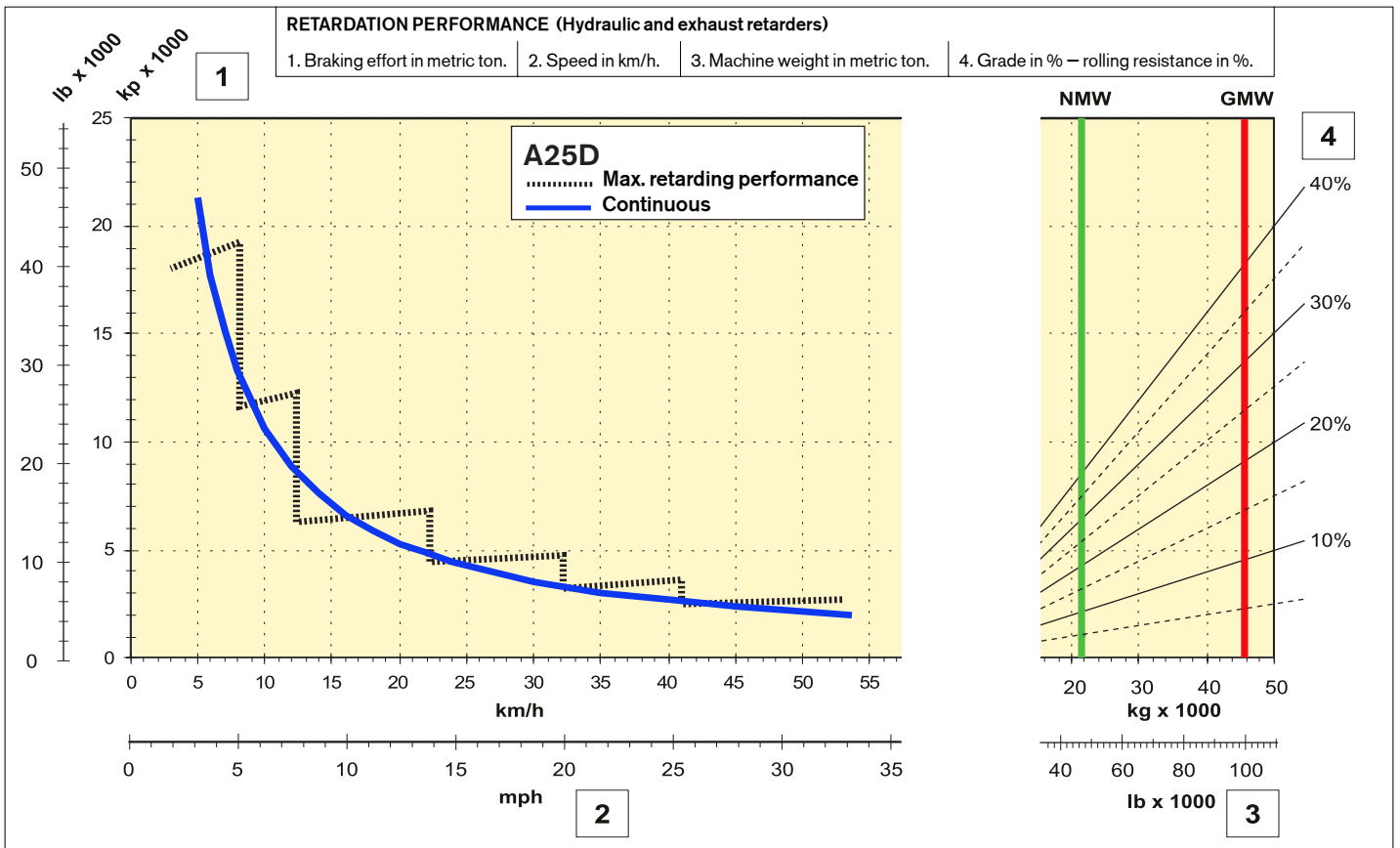

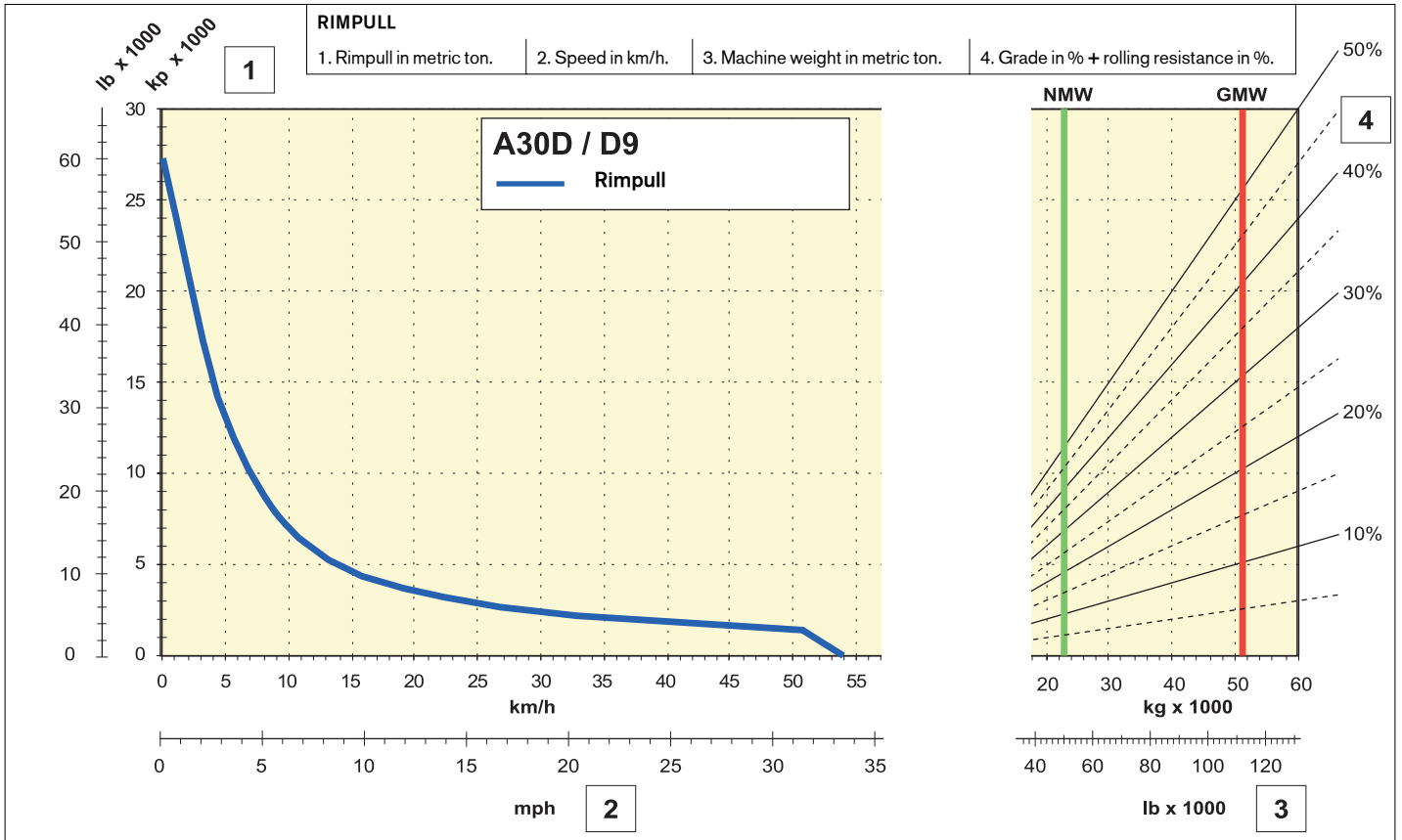

Instructions

Diagonal lines represent total resistance (grade % ± rolling resistance %). Charts based on 0% rolling resistance, standard tires and gearing, unless otherwise stated.

- Find the diagonal line with the appropriate total resistance on the right-hand edge of the chart.
- Follow the diagonal line downward until it intersects the actual machine weight line, NMW or GMW.
- Draw a new line horizontally to the left from the point of intersection until the new line intersects the rimpull or retardation curve.
- Read down for vehicle speed.

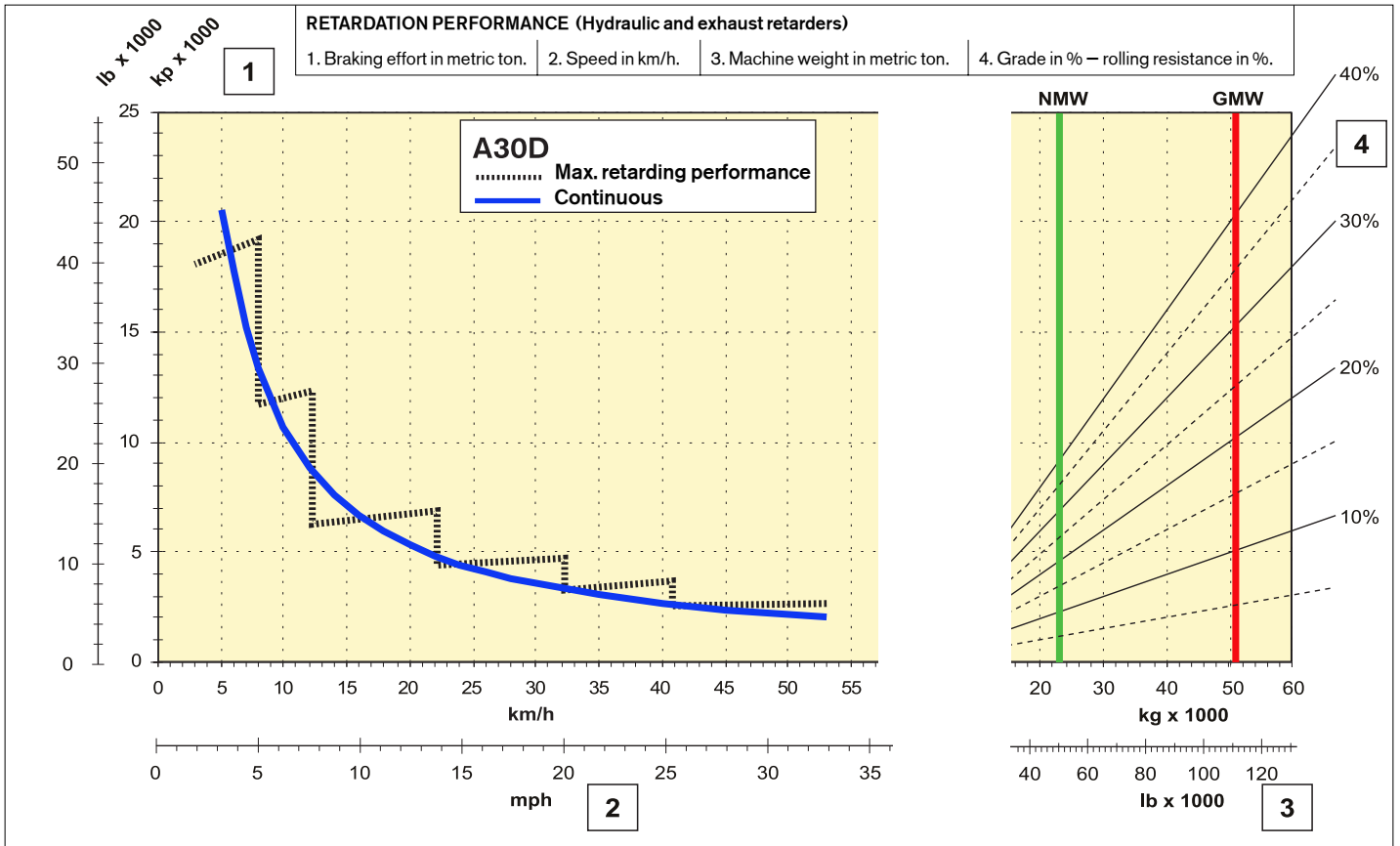

Specifications A25D - A30D Light Material

Pos	Metric (mm)		Imperial (Feet)	
	A25D	A30D	A25D	A30D
A	10 790	10 891	35'5"	35'9"
C	3 428	3 428	11'3"	11'3"
C ₁	3 318	3 318	10'11"	10'11"
C ₂	1 768	1 768	5'10"	5'10"
D	2 764	2 764	9'1"	9'1"
E	1 210	1 210	4'0"	4'0"
F	4 175	4 175	13'8"	13'8"
G	1 670	1 670	5'6"	5'6"
H	1 610	1 688	5'3"	5'6"
I	608	608	2'0"	2'0"
J	3 457	3 606	11'4"	11'10"
L	391	396	1'3"	1'4"
M	6 559	6 735	21'6"	22'1"
N	7 980	7 980	26'5"	26'2"
N ₁	4 070	4 070	13'4"	13'4"
O	2 834	3 034	9'4"	9'11"
P	700	750	2'4"	2'6"
R	512	513	1'8"	1'8"
R ₁	634	635	2'1"	2'1"
U	3 257	3 310	10'8"	10'10"
V	2 258	2 216	7'5"	7'3"
V*	-----	2 258	-----	7'5"
W	2 859	2 941	9'5"	9'8"
W*	-----	2 859	-----	9'5"
X	456	456	1'6"	1'6"
X ₁	581	582	1'11"	1'11"
X ₂	659	659	2'2"	2'2"
Y	2 258	2 216	7'5"	7'3"
Y*	-----	2 258	-----	7'5"
Z	2 859	2 941	9'5"	9'8"
Z*	-----	2 859	-----	9'5"
a ₁	23,5°	23,5°	23,5°	23,5°
a ₂	74°	70°	74°	70°
a ₃	45°	45°	45°	45°

A25D: Unloaded machine with 23,5R25
A30D: Unloaded machine with 750/65R25
* A30D with optional 23,5R25 tires

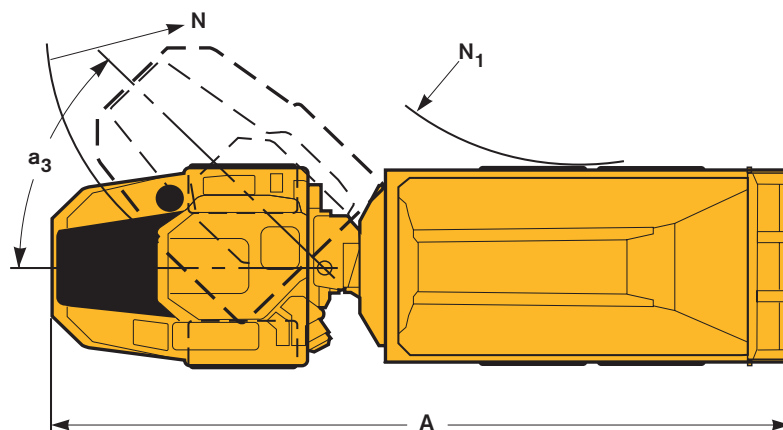
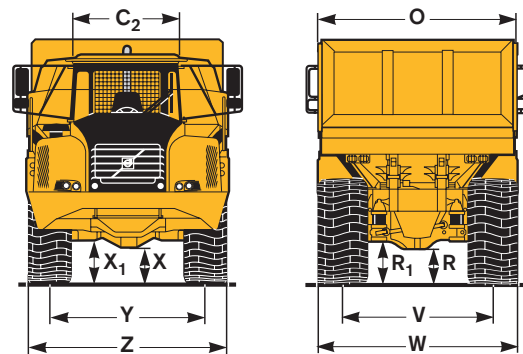
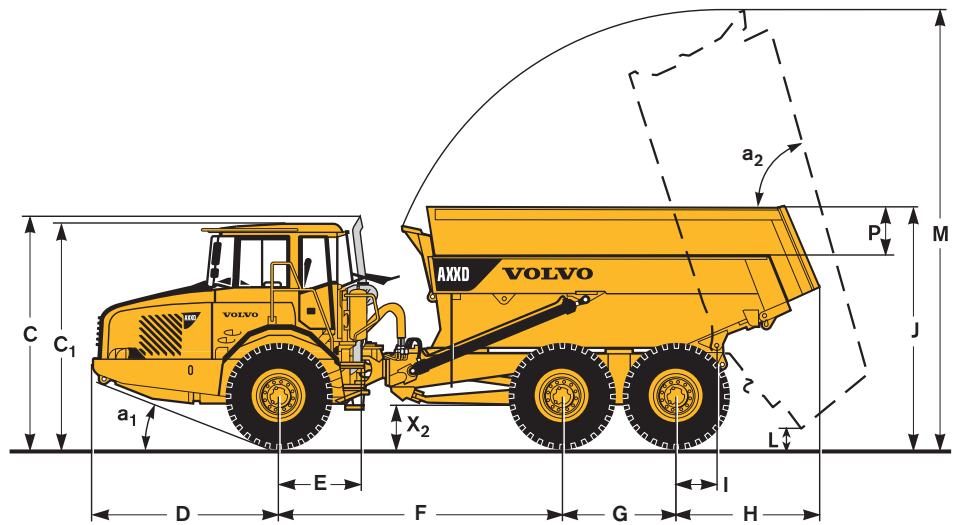

STANDARD EQUIPMENT

Safety

ROPS/ FOPS protected cab
Service platform for ease of service
Anti-slip material on hood and fenders
Hazard lights
Horn
Protective grille for rear window
Rear-view mirrors
Retractable 3-inch safety belt
Secondary steering
Steering joint locking assembly
Dump body lock
Handrails on fenders
Windshield wipers with interval function
Windshield washers

Comfort

Tilt/telescopic steering wheel
Cab heater with filtered fresh air and defroster
Overhead console for radio
Sun visor
Tinted glass
Can holder /storage tray
Cigarette lighter
Ashtray
Space for lunch cooler
Storage box

Engine

Direct injected, electronically controlled
Turbocharged, intercooled
Remote oil drain plug
Remote oil filters, for ease of access
Preheater for easier cold starts
Coolant filter

Electrical system

Alternator, 55 A
Battery disconnect switch
Electrical outlets, 24V in cab
Lights:
• Headlights
• Parking lights
• Direction indicators
• Rear lights
• Back-up lights
• Brake lights
• Cab lighting
• Instrument lighting
Pilot lights for all switches

Operator information interface

Gauges:
• Speedometer
• Tachometer
• Brake pressure
• Fuel
• Transmission oil temperature

Warning lights grouped and easy to read
Central warning (3 levels) for all vital functions

Central positioned information display:
• Automatic pre-start checks
• Operation information, easy-to-find menu
• Troubleshooting diagnostics
• Hour meter
• Clock
• Machine settings

Drivetrain

Automatic transmission
Torque converter with automatic lock-up
Variable hydraulic transmission retarder
Dropbox, single-stage
6x4 or 6x6 operator selectable drive modes
100% longitudinal differential lock
100% differential locks in all axles

Brakes

Air-hydraulic disc brakes
Two circuit brake system
Parking brake on prop shaft

Body

Light material body, material density 0,9 t/m³
Body prepared for exhaust heating
Load and Dump brake

Tires

A25D: 23,5R25
A30D: 750/65R25

Other

Air drier

OPTIONAL EQUIPMENT

Safety

Fire-extinguisher and first aid kit

Service and maintenance

Tool kit with tire inflation unit
Electrical hood opening

Engine

Extra air cleaner, heavy-duty
Extra air cleaner, oil bath type
External emergency engine stop
Delayed engine stop
Electric engine heater (120V or 240V)
Engine and cab heater, diesel **
Fast fuel filling system **

Electrical

Work lights, roof mounted
Work lights, rear-facing, fender-mounted
Rotating beacon, collapsible mount
Rotating beacon at rear end **
Back-up alarm
Rear vision system
Anti-theft system (prevents engine start)
Headlights for left-hand traffic
Alternator, heavy-duty 80 A
Battery charger **
Jump start connection, NATO **
Back up light, extra **
Cab heater, electrical **

Cab

Air suspended, electrically heated operator's seat
Seat cover **
Instructor seat with seat belt
Electrically heated rear-view mirrors
Air conditioning
Radio installation kit
Radio
Cable kit for cab heater (120V or 240V)
Window tint film

External

Rear mudflaps

Body

Body exhaust heating kit

Tires

A25D: 650/65R25
A30D: 23,5R25

Other

Synthetic hydraulic oil (biologically degradable)
Arctic oil kit
Toolbox
Dumping angle limitation (hydraulic) **
Towing Hitch

(* * Special Optional Equipment)

Under our policy of continual product improvement, we reserve the right to change specifications and design without prior notice. The illustrations do not necessarily show the standard version of the machine.

VOLVO

Construction Equipment

Ref. No 21 2 669 4172 English
Sweden 2003-11 ART
Volvo Växjö