

VOLVO DOUBLE DRUM COMPACTORS

# DD110B, DD120B, DD140B

11-14 t (24,640-31,360 lb), 98-110 kW (131.5-148 hp)



# ULTIMATE VERSATILITY.



## Machine size

Volvo offers you three platforms so you can select the machine size appropriate for your compacting job. The DD110B, DD120B and DD140B provide you with different weight and rolling widths for consistent, high density levels and ultimate performance and productivity – ensuring you meet your targets on time.

Volvo offers you a range of compactors so you can choose the machine that best matches your needs. Whether you're compacting on a highway or airport, wide or deep pavements and on Roller Compacted Concrete (RCC), Warm Mix Asphalt (WMA) or any other material – Volvo compactors boast the best compaction in the market place. Whatever your requirements, Volvo has the best compactor for the job.

**Two amplitudes**

For operational simplicity, high or low amplitude is selected on the control panel allowing the operator to adjust drum force when application or material depth changes. Volvo's dual amplitude and frequency compactors allow the drum energy to be easily altered for improved performance and productivity.



**Eight amplitudes**

For versatility, eight amplitude settings increase or decrease compaction depth by changing the drum energy. This allows the operator to optimally adjust drum performance and achieve target density over varying conditions – from tender to tough mixes. Smoothness is enhanced through auto-reversing eccentrics.



**Eight amplitudes HFA**

For ultimate performance and maximum versatility, the Volvo High Frequency and Amplitude (HFA) compactor provides automated features – increasing productivity. The machine features automatic smooth start-up of vibration, eccentric rotation - which matches travel direction - and smart vibration which adjusts the frequency when amplitude is changed.

# INTELLIGENT DESIGN.

Volvo compactors are designed for maximum efficiency and simple operation. Smart features including an industry-leading water system deliver straightforward operation and compaction at its best. Benefit from powerful performance and high density levels with Volvo compaction equipment.



## Drum performance

High centrifugal force, optimal drum weight and variable amplitude combine to achieve the target material density in fewer passes.

# 6 to 8



# 4 to 6



# 1 to 3



## Frame design

Robust box frame design provides the compactor with superior frame strength, allowing for excellent drum support, all built into a low profile design.



## Impact spacing meter

The operator can easily monitor drum impact spacing via the console display. This provides a visual reference for rolling speed and allows the operator to make adjustments and ensure the correct spacing needed for consistent smoothness and quality.



#### **Water system**

Industry-leading, automatic drum wetting system provides uniform drum coverage with variable flow – preventing material pick-up for reduced downtime. Features include independent front and rear systems with primary and backup pumps, spray bars, nozzles, triple filtration and drum wipers.

# 360° VISIBILITY.



## All-around visibility

The design of the DD110B, DD120B and DD140B gives you a 360° view of the entire work zone for maximum safety and productivity. Unobstructed views allow the operator to work comfortably and ensure the safety of the entire crew.

For safety, comfort and all-around visibility Volvo has designed a premium ROPS/FOPS protected operator environment. The operator platform is surrounded by guard railings which provide safety when entering and exiting the machine. Adjustable seating enables easy access to the controls for increased productivity and ease of operation.



#### Rotating console

The operator console can be rotated to five different positions – allowing the seat to be positioned for maximum visibility and comfort. The interface of the drum, with panel edges and joints as well as curbs and guide railings, is visible from the operator seat for safe operation and increased productivity.



#### Presence switch

If the operator leaves the seat with the engine running and the parking brake not applied the machine will shut down. With the parking brake applied, the operator can safely exit the machine.



#### Seatbelt alert

Safety is improved by reminding the operator with an audible alarm and visual indicator to buckle the seatbelt during machine operation.

# SUPERIOR COMPACTION.

## Impact spacing meter

Easy monitoring of impact spacing permits rolling speed adjustments that help maintain pavement smoothness.



## Rotating console

Operator console can be rotated to five positions allowing maximum comfort and visibility.

## Vibration control HFA

On the HFA compactor, the automatic vibration system controls the machine's maximum speed in relationship to the machine's frequency – maintaining the correct impact spacing.



## Tier 4i engine

Volvo engines provide a 'one-stop-shop' approach with support, parts and warranty handled by your local Volvo dealer.

## Selectable amplitudes

For two amplitude machines, high or low amplitude is selected on the control panel allowing the operator to adjust the drum force when application or material depth changes.



## Drum performance

High centrifugal force combined with drum amplitude, frequency and weight delivers excellent compaction.







#### All-around visibility

Benefit from a 360° view of the entire work zone for maximum safety and productivity.

#### Vandalism protection

Lockable vandal cover protects the console. Lockable engine hood, fuel cap, water fill caps and access doors deter theft and vandalism.



#### Water system

Industry-leading, automatic drum wetting system provides uniform drum coverage to prevent material pick-up.

#### Frame design

Superior drum performance is enabled by robust box frame design. Low machine profile increases visibility.

#### Eccentric rotation

For eight amplitude machines, this automatic function ensures eccentric rotation in the direction that the machine is travelling for improved smoothness.

#### Water tanks

For quick and easy access the water tanks can be safely filled from ground level.

# YOUR UPTIME IS OUR PRIORITY.



## Support network

Volvo offers customers access to its first-class dealer support network. A factory trained technician, in a Volvo dealer service truck, with Genuine Volvo Parts will be ready to service your compaction equipment at your convenience. Trust Volvo to maintain your uptime.

At Volvo we're not just committed to providing you with compaction equipment. Consult with Volvo experts to benefit from years of experience on your compaction and paving projects. We know that on a compacting job, time and quality mean money. And that's why Volvo has a unique, dealer support network to ensure your machine's uptime. Enjoy maintenance made easy and continuous state-of-the-art support with Volvo.



**Volvo maintained**

Volvo engines are built and maintained by Volvo. Because your compactor is 100% Volvo, you'll benefit from a 'one-stop-shop' approach – with support, parts and warranty dealt with in one place by your local Volvo dealer.

**Road Institute**

The Volvo Road Institute has been teaching customers how to operate and service compactors and pavers since its inception in 1965. Operators are educated by experienced instructors on best practice techniques and taught how to recognize and correct problems.



**Customer Support Agreement**

Volvo Customer Support Agreements (CSA) offer service and maintenance with maximum cost control and minimum downtime. The flexible system caters for a range of needs from total repair and maintenance to an inspection program covering vital parts and functions.

# SPECIFICATIONS.

Model	DD110B							
			2 amplitudes		8 amplitudes		HFA	
<b>Machine Weights (w/ ROPS / FOPS)</b>								
Operating Weight (CECE)	kg	lb	11 250	<b>24,807</b>	11 250	<b>24,807</b>	11 250	<b>24,807</b>
Weight @ Front Drum	kg	lb	5 344	<b>11,784</b>	5 344	<b>11,784</b>	5 344	<b>11,784</b>
Weight @ Rear Drum	kg	lb	5 497	<b>12,121</b>	5 497	<b>12,121</b>	5 497	<b>12,121</b>
Shipping Weight	kg	lb	10 537	<b>23,235</b>	10 537	<b>23,235</b>	10 537	<b>23,235</b>
<b>Drum</b>								
Width	mm	in	1 700	<b>66.9</b>	1 700	<b>66.9</b>	1 700	<b>66.9</b>
Diameter	mm	in	1 300	<b>51.2</b>	1 300	<b>51.2</b>	1 300	<b>51.2</b>
Shell Thickness (no minal)	mm	in	20	<b>0.79</b>	20	<b>0.79</b>	20	<b>0.79</b>
Finish	mm	in	Machined surface; chamfered & radiused edges					
<b>Propulsion</b>								
Type	Closed-loop hydrostatic, parallel circuit to both drums							
Drum Drive	Heavy-duty radial piston LSHT motors; 2-speed rear motor							
Travel Speed	High	km/h	mph	13	<b>8.1</b>	13	<b>8.1</b>	13
	Low	km/h	mph	7.6	<b>4.7</b>	7.6	<b>4.7</b>	7.6
<b>Engine</b>								
Make / Model	Volvo Deutz D4							
Engine Type	4 Cyl, Electronic, Turbocharged, CAC, U.S. EPA Tier 4 interim							
Rated Power @ Installed Speed	kW	hp	98.1	<b>131.5</b>	98.1	<b>131.5</b>	98.1	<b>131.5</b>
Electrical	24 volts DC, negative ground; 120 A alternator							
<b>Brakes</b>								
Service	Dynamic hydrostatic through propulsion system							
Parking / Secondary	SAHR on front-drum & rear-drum drive motors							
<b>Water System</b>								
Type	Pressure spray drum wetting system with LDPE water tanks							
Pumps	Diaphragm water pumps, primary and secondary for each drum							
Spray Bars	Primary and secondary spray bars for each drum							
Nozzles	Hand-serviceable fan spray nozzles; 10 per spray bar							
Filtration	Sock strainer each tank; primary water filter each pump, fine filter each nozzle							
Drum Wipers	Front & rear Styrene wipers for each drum							
Water Tank Capacity	l	gal	548.8	<b>145</b>	548.8	<b>145</b>	548.8	<b>145</b>
<b>Miscellaneous</b>								
Inside Turning Radius (to drum edge)	mm	in	3 889	<b>153.1</b>	3 889	<b>153.1</b>	3 889	<b>153.1</b>
Articulation Angle (center pivot steering)	+ / - 40°							
Oscillation Angle	+ / - 10°							
Fuel Tank Capacity	l	gal	189.3	<b>50</b>	189.3	<b>50</b>	189.3	<b>50</b>
Hydraulic Oil Capacity	l	gal	128	<b>33.8</b>	128	<b>33.8</b>	128	<b>33.8</b>
Gradeability (theoretical)			31%		31%		31%	

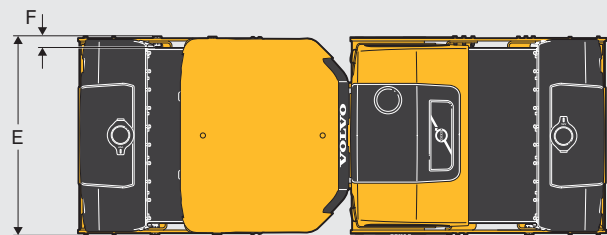
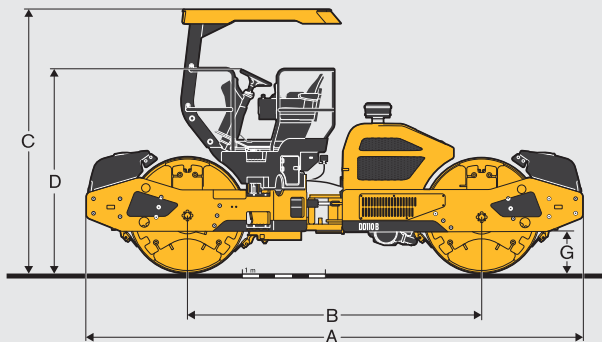

Model	DD120B						DD140B				
	2 amplitudes		8 amplitudes		HFA		2 amplitudes				
<b>Machine Weights (w/ ROPS / FOPS)</b>											
Operating Weight (CECE)	kg	lb	12 702	<b>28,008</b>	12 702	<b>28,008</b>	12 702	<b>28,008</b>	14 396	<b>31,744</b>	
Weight @ Front Drum	kg	lb	6 018	<b>13,271</b>	6 018	<b>13,271</b>	6 018	<b>13,271</b>	7 578	<b>16,710</b>	
Weight @ Rear Drum	kg	lb	6 683	<b>14,737</b>	6 683	<b>14,737</b>	6 683	<b>14,737</b>	6 818	<b>15,034</b>	
Shipping Weight	kg	lb	11 981	<b>26,420</b>	11 981	<b>26,420</b>	11 981	<b>26,420</b>	13 681	<b>30,168</b>	
<b>Drum</b>											
Width	mm	in	2 000	<b>78.7</b>	2 000	<b>78.7</b>	2 000	<b>78.7</b>	2 136	<b>84.1</b>	
Diameter	mm	in	1 400	<b>55.1</b>	1 400	<b>55.1</b>	1 400	<b>55.1</b>	1 400	<b>55.1</b>	
Shell Thickness (nominal)	mm	in	20	<b>0.78</b>	20	<b>0.78</b>	20	<b>0.78</b>	20	<b>0.78</b>	
Finish	Machined surface; chamfered & radiused edges										
<b>Propulsion</b>											
Type	Closed-loop hydrostatic, parallel circuit to both drums										
Drum Drive	Heavy-duty radial piston LSHT motors; 2-speed rear motor										
Travel Speed	High	km/h	mph	11.4	<b>7.1</b>	11.4	<b>7.1</b>	11.4	<b>7.1</b>	11.4	<b>7.1</b>
	Low	km/h	mph	8.6	<b>5.3</b>	8.6	<b>5.3</b>	8.6	<b>5.3</b>	8.6	<b>5.3</b>
<b>Engine</b>											
Make / Model	Volvo Deutz D4										
Engine Type	4 Cyl, Electronic, Turbocharged, CAC, U.S. EPA Tier 4 interim										
Rated Power @ Installed Speed	kW	hp	110.4	<b>148</b>	110.4	<b>148</b>	110.4	<b>148</b>	110.4	<b>148</b>	
Electrical	24 volts DC, negative ground; 120 A alternator										
<b>Brakes</b>											
Service	Dynamic hydrostatic through propulsion system										
Parking / Secondary	SAHR on front-drum & rear-drum drive motors										
<b>Water System</b>											
Type	Pressure spray drum wetting system with LDPE water tanks										
Pumps	Diaphragm water pumps, primary and secondary for each drum										
Spray Bars	Primary and secondary spray bars for each drum										
Nozzles	Hand-serviceable fan spray nozzles; 10 per spray bar										
Filtration	Sock strainer each tank; primary water filter each pump, fine filter each nozzle										
Drum Wipers	Front & rear Styrene wipers for each drum										
Water Tank Capacity	l	gal	605.6	<b>160</b>	605.6	<b>160</b>	605.6	<b>160</b>	639.7	<b>169</b>	
<b>Miscellaneous</b>											
Inside Turning Radius (to drum edge)	mm	in	3 772	<b>148.5</b>	3 772	<b>148.5</b>	3 772	<b>148.5</b>	4 562	<b>179.6</b>	
Articulation Angle (center pivot steering)							+ / - 40°		+/- 35°		
Oscillation Angle							+ / - 10°		+/- 10°		
Fuel Tank Capacity	l	gal	258.5	<b>68.3</b>	258.5	<b>68.3</b>	258.5	<b>68.3</b>	301	<b>79.5</b>	
Hydraulic Oil Capacity	l	gal	140	<b>37</b>	140	<b>37</b>	140	<b>37</b>	143.8	<b>38</b>	
Gradeability (theoretical)			35.2		35.2		35.2		30.1		

## DIMENSIONS

			DD110B		DD120B		DD140B	
A Overall Length	mm	in	5 795	<b>228.1</b>	5 995	<b>236.0</b>	5 995	<b>236.0</b>
B Drum Base	mm	in	3 450	<b>135.8</b>	3 550	<b>139.8</b>	3 550	<b>139.8</b>
C Overall Height (top of ROPS / FOPS)	mm	in	3 140	<b>123.6</b>	3 187	<b>125.5</b>	3 200	<b>126.0</b>
D Overall Height (top of steering wheel)	mm	in	2 386	<b>93.9</b>	2 463	<b>97.0</b>	2 470	<b>97.2</b>
E Overall Width	mm	in	1 920	<b>75.6</b>	2 249	<b>88.5</b>	2 375	<b>93.5</b>
F Side Clearance	mm	in	110	<b>4.3</b>	125	<b>4.9</b>	120	<b>4.7</b>
G Curb Clearance	mm	in	460	<b>18.1</b>	510	<b>20.1</b>	510	<b>20.1</b>

# SPECIFICATIONS.

DD110B																		
2 amplitudes																		
High Frequency - Low amplitude									Low Frequency - High amplitude									
Nominal amplitude	mm	in	0.42			0.0165			0.89			0.035						
Vibration frequency	Hz	vpm	70			4,200			50			3,000						
Eccentric Force	kN	lb	203			45,568			215			48,268						
8 amplitudes																		
Handwheel Setting			1	2	3	4	5	6	7	8								
Nominal amplitude	mm	in	0.25	0.01	0.29	0.0113	0.36	0.0142	0.45	0.0176	0.53	0.0207	0.59	0.0232	0.63	0.0248	0.64	0.0253
Vibration frequency	Hz	vpm	62									3,720						
Eccentric Force	kN	lb	69.3	15,590	78.1	17,560	98.5	22,150	122.1	27,460	143.9	32,350	161	36,190	171.8	38,630	175.5	39,460
8 amplitudes HFA																		
Handwheel Setting			1	2	3	4	5	6	7	8								
Nominal amplitude	mm	in	0.42	0.0165	0.45	0.0179	0.54	0.0212	0.64	0.0253	0.74	0.0292	0.82	0.0323	0.87	0.0343	0.89	0.035
Vibration frequency	Hz	vpm	70	4,200	67.5	4,050	63.3	3,800	60	3,600	55	3,300	53.3	3,200	50	3,000	50	3,000
Eccentric Force	kN	lb	145.8	32,813	146.9	33,048	153.7	34,594	164.6	37,036	159.5	35,889	165.9	37,327	154.8	34,819	157.8	35,510
DD120B																		
2 amplitudes																		
High Frequency - Low amplitude									Low Frequency - High amplitude									
Nominal amplitude	mm	in	0.36			0.014			0.89			0.035						
Vibration frequency	Hz	vpm	70			4,200			50			3,000						
Eccentric Force	kN	lb	209			47,094			249			56,074						
8 amplitudes																		
Handwheel Setting			1	2	3	4	5	6	7	8								
Nominal amplitude	mm	in	0.38	0.0149	0.40	0.0157	0.46	0.018	0.53	0.0208	0.60	0.0235	0.65	0.0257	0.69	0.0271	0.70	0.0276
Vibration frequency	Hz	vpm	51.5	3,090	51.5	3,090	51.5	3,090	51.5	3,090	51.5	3,090	51.5	3,090	51.5	3,090	51.5	3,090
Eccentric Force	kN	lb	84.4	18,980	89.4	20,100	102	22,940	118	26,520	133.4	29,990	145.9	32,810	154	34,630	156.8	35,250
8 amplitudes HFA																		
Handwheel Setting			1	2	3	4	5	6	7	8								
Nominal amplitude	mm	in	0.36	0.014	0.40	0.0157	0.50	0.0197	0.62	0.0244	0.73	0.0287	0.82	0.0321	0.87	0.0342	0.89	0.0349
Vibration frequency	Hz	vpm	70	4,200	66.7	4,000	60	3,600	56.7	3,400	53.3	3,200	51.7	3,100	50	3,000	50	3,000
Eccentric Force	kN	lb	147.2	33,090	149.8	33,670	152.2	34,220	167.8	37,720	174.8	39,300	183.3	41,220	183.2	41,190	187.1	42,070
DD140B																		
2 amplitudes																		
High Frequency - Low amplitude									Low Frequency - High amplitude									
Nominal amplitude	mm	in	0.35			0.014			0.88			0.035						
Vibration frequency	Hz	vpm	66.7			4,000			45			2,700						
Eccentric Force	kN	lb	234			52,552			256			57,592						

# EQUIPMENT.

## STANDARD EQUIPMENT

	DD110B	DD120B	DD140B
Volvo engine	•	•	•
Engine fan guard	•	•	•
Engine grid heater	•	•	•
Diesel Particulate Filter (DPF)	•	•	•
Fuel/water separator	•	•	•
Air filter restriction	•	•	•
Engine shock mounts	•	•	•
Five-position rotating console	•	•	•
Seat belt alarm	•	•	•
Operator platform isolation	•	•	•
Fully adjustable seat	•	•	•
Anti-slip steps and operator platform	•	•	•
Tilt steering wheel	•	•	•
Control panel cover	•	•	•
Retracting seat belt	•	•	•
High centrifugal force	•	•	•
Automatic eccentric rotation	•	•	•
Smart start	•	•	•
Vibration isolation	•	•	•
Machine finished drums	•	•	•
Pressurized water system with variable flow and triple filtration	•	•	•
Water tank level indicator	•	•	•
Quick removal water nozzles and screens	•	•	•
Automatic tensioning wipers	•	•	•
Service chart with detailed check points	•	•	•
Tow feature	•	•	•
ROPS / FOPS	•	•	•
Impact spacing meter	•	•	•
Selectable auto vibration	•	•	•
Smart vibration	•	•	•
Smart water	•	•	•
Smart propulsion	•	•	•
Power port	•	•	•
On board processor diagnosis	•	•	•
24 volt system	•	•	•

## OPTIONAL EQUIPMENT

	DD110B	DD120B	DD140B
2 Amplitude HF Feature	•	•	•
8 Amplitude HF Feature	•	•	•
8 Amplitude HFA Feature	•	•	•
Drum Wiper - Styrene	•	•	•
Drum Wiper - Urethane	•	•	•
Cocoa Mat Drum Wiper	•	•	•
Back-up Alarm	•	•	•
Infrared Temperature Option	•	•	•
Pre-Cleaner Air filter feature	•	•	•
Fuel Strainer Option	•	•	•
Bio-degradable Oil	•	•	•
Work Lights	•	•	•
HID 1 Light Package	•	•	•
HID 2 Light Package	•	•	•
Strobe Light	•	•	•
Winterization Feature	•	•	•
Maintenance Package	•	•	•
Metric Tool Kit	•	•	•
ROPS Ship Loose	•	•	•
Special Paint	•	•	•

## SELECTION OF VOLVO OPTIONAL EQUIPMENT

8 Amplitude



Drum Wiper



Air pre-cleaner



Maintenance Package



HID lights and strobe



# VOLVO CONSTRUCTION EQUIPMENT



Volvo Construction Equipment is different. Our machines are designed, built and supported in a different way. That difference comes from an engineering heritage of over 180 years. A heritage of thinking first about the people who actually use the machines. About how to help them be safer, more comfortable, more productive. About the environment we all share. The result of that thinking is a growing range of machines and a global support network dedicated to helping you do more. People around the world are proud to use Volvo.

Not all products are available in all markets. Under our policy of continuous improvement, we reserve the right to change specifications and design without prior notice. The illustrations do not necessarily show the standard version of the machine.

## **VOLVO**

**Volvo Construction Equipment**  
[www.volvoce.com/na](http://www.volvoce.com/na)

Ref. No. VOE2210009282  
Printed in USA 12/12 - 0,0  
Volvo, Asheville  
Copyright © 2012 Volvo

English  
USA

*Courtesy of Machine.Market*