

VOLVO WHEEL LOADER

L120C

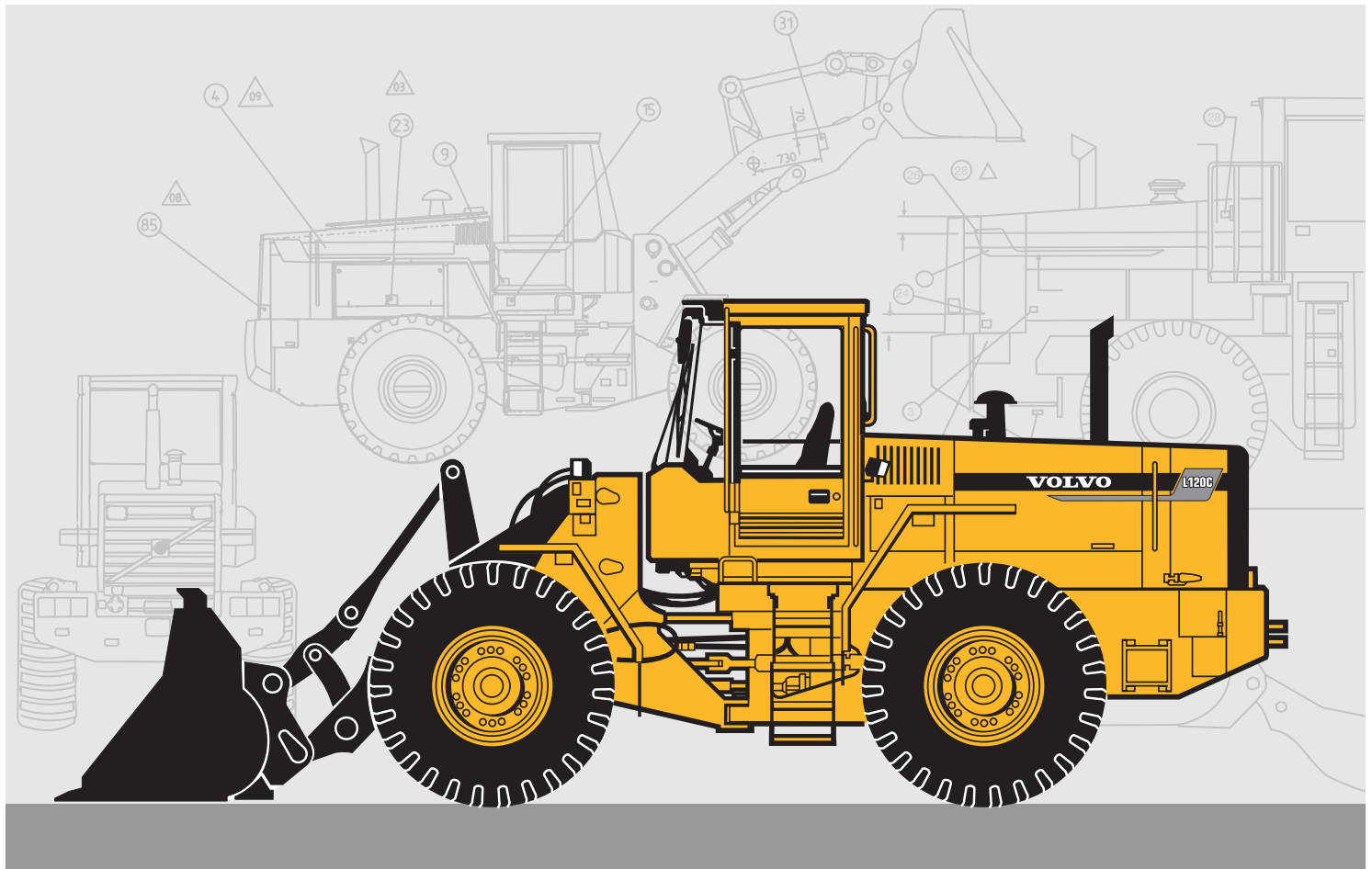

- **Engine output SAE J1349:**
gross 153 kW (208 hp)
net 148 kW (201 hp)
 - **Operating weight:** 18,0–20,2 t
 - **Buckets:** 3,0–9,5 m³
 - **Volvo high performance-low emission engine**
 - with excellent low rpm lugging performance
 - meets all known exhaust emission regulations for off-road vehicles until 2002
 - **Volvo transmission with APS II**
 - 2nd generation Automatic Power Shift with mode selector
 - optimises performance
 - **Wet disc brakes**
 - fully sealed oil-circulation cooled
 - outboard mounted
 - **Torque Parallel Linkage**
 - high breakout torque through out the working range
 - excellent parallel lift-arm action
 - **Care Cab** – pressurized cab with high comfort and safety
 - **Contronic monitoring system**
 - **Load-sensing steering system**
 - Pilot-operated working hydraulics
- Optional Equipment**
- Hydraulic attachment bracket
 - Long Boom
 - Boom Suspension System
 - Comfort Drive Control

VOLVO



SERVICE REFILL CAPACITIES

Contronic monitoring system provides information on machine condition, routine maintenance schedules and minimizes time required for troubleshooting.

Service accessibility: Large, easy-to-open engine access doors with gas struts. Hinged radiator grille and radiator.

Fuel tank	255 l	Transmission	33 l
Engine coolant	65 l	Engine oil	22 l
Hydraulic tank.....	155 l	Axle front / rear	36/41 l



ENGINE

Engine delivers high torque and quick response at low rpm even under full load. The machine can work at low engine speeds, which contributes to good fuel economy, less noise, less wear and longer life.

Engine: 6-cylinder, in-line, direct-injected, turbocharged, intercooled 4-stroke diesel engine with wet replaceable cylinder liners.

Air cleaning: three-stage.

Engine	Volvo TD 73 KDE
Flywheel output at	35 r/s (2 100 r/min)
SAE J1349 gross	153 kW (208 hp)
SAE J1349 net	148 kW (201 hp)
Max. torque at	18,3 r/s (1 100 r/min)
SAE J1349 gross	925 Nm
SAE J1349 net	920 Nm
Displacement	6,7 l

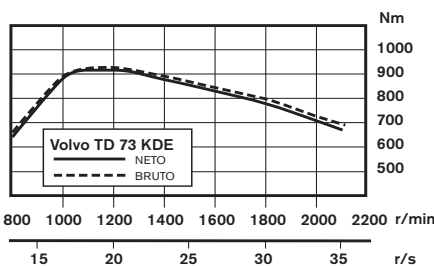

ELECTRICAL SYSTEM

Contronic monitoring system with complete information on the status of the machine's various systems is standard. Electrical system with circuit board is well protected by fuses. Prepared for retrofitting of optional equipment.

Central warning: Central warning lamp for the following functions: engine oil pressure, engine coolant temperature (with buzzer), hydraulic oil pressure in transmission, transmission oil temperature, brake pressure, parking brake (buzzer), shut down to idle as standard.

Voltage	24 V
Batteries	2x12 V
Battery capacity	2x105 Ah
Cold cranking capacity, ea	560 A
Reserve capacity, ea	170 min
Alternator rating	1 680 W / 60 A
Starter-motor output	5,4 kW (7,3 hp)



DRIVETRAIN

Drivetrain and working hydraulics well-matched to each other. Dependable design. Quick acceleration boosts productivity. Volvo system-compatible design facilitates servicing.

Torque converter: Single-stage

Transmission: Volvo Power Shift transmission of countershaft type with single-lever control. Fast and smooth forward / reverse shifting.

Shifting system: Volvo Automatic Power Shift (APS II) with mode selector.

Axes: Volvo, fully floating axle shafts with planetary-type hub reductions. Cast-steel axle housing. Fixed front axle and oscillating rear axle. 100 % differential lock on front axle.

Transmission	Volvo HT 205
Torque multiplication	2,85:1
Speeds, max forward/reverse	
1	7,3 km/h
2	13,3 km/h
3	25,2 km/h
4 (forward only)	35,5 km/h
Measured with tires	23.5 R25* L2
Front axle	Volvo / AWB 31
Rear axle	Volvo / AWB 30
Oscillation, rear axle	±13°
Ground clearance at 13° oscillation	463 mm



BRAKE SYSTEM

Simple, reliable system with few parts ensures high availability and safety. Self-adjusting internal oil circulation-cooled disc brakes give long service intervals.

Service brakes: Volvo, dual-circuit system with nitrogen-charged accumulators for dead engine braking. Fully hydraulically operated enclosed internal oil circulation-cooled, outboard mounted disc brakes. Transmission declutch during braking can be preselected by a switch on the instrument panel. Brake performance test by the Contronic system.











Parking brake: Enclosed wet multi-disc brake built into the transmission. Spring-loaded application. Electro-hydraulic release via a switch on the instrument panel.

Secondary brake: Either of the service brake circuits or the parking brake fullfills ISO/SAE safety requirements. Automatically applied when the key is turned off.

Standards: The brake system complies with the requirements of ISO 3450, SAE J1473

Number of discs/wheel	1
Number of accumulators	2
Volume, each	0,5 l

OPERATIONAL DATA VOLVO L120C

		GENERAL PURPOSE						ROCK	LIGHT MATERIAL	LONG BOOM	
											
Tires 23.5 R25		Teeth	Bolt-on edge	Teeth	Bolt-on edge	Bolt-on edge	Bolt-on edge	Teeth Segments	Bolt-on edge	Bolt-on edge	Bolt-on edge
Volume, heaped ISO/SAE	m ³	3,0	3,1	3,3	3,4	3,4	3,6	3,1	5,5	2,6	2,6
Actual volume, 110%	m ³	3,3	3,4	3,6	3,7	3,7	4,0	–	6,1	2,9	2,9
Static tipping load, straight	kg	13 860	13 640	13 530	12 860	13 460	13 340	13 400	12 370	10 770	11 300
at 35° turn	kg	12 200	12 010	11 900	11 260	11 820	11 700	11 760	10 800	9 400	9 900
at full turn	kg	11 720	11 520	11 410	10 770	11 320	11 190	11 270	10 320	8 990	9 480
Breakout force	kN	160,6	152,3	152,5	134,2	145,0	140,7	152,4	106,7	158,0	172,4
A	mm	8 110	7 970	8 180	8 150	8 040	8 090	8 140	8 530	8 450	8 340
E	mm	1 140	1 220	1 200	1 380	1 280	1 320	1 230	1 730	1 220	1 130
H *)	mm	2 820	2 910	2 770	2 790	2 860	2 830	2 800	2 500	3 450	3 520
L	mm	5 620	5 620	5 690	5 740	5 690	5 730	5 660	5 900	6 080	6 020
M *)	mm	1 330	1 190	1 380	1 320	1 240	1 270	1 310	1 570	1 150	1 070
N *)	mm	1 890	1 800	1 910	1 860	1 820	1 830	1 860	1 910	2 230	2 180
V	mm	2 880	2 880	2 880	2 880	2 880	2 880	2 880	3 000	2 880	2 880
a ₁ clearance circle	mm	12 970	12 830	13 020	12 940	12 870	12 900	12 970	13 290	13 310	13 230
Operating weight	kg	18 630	18 700	18 710	18 890	18 780	18 830	18 910	19 190	19 030	18 810

*) at dump angle 45° Including counterweight 1

BUCKET SELECTION CHART

The choice of bucket is determined by the density of the material and the bucket fill factor. The TP-linkage uses a very open bucket design, has very good roll back in all positions plus fills the bucket very well. This means that the actual volume carried is often larger than the rated capacity of the bucket. Bucket fill factors of different materials and how they affect the actual bucket volume are shown in the table. **Example: Sand and gravel. Fill factor ~105%. Density 1,6 ton/m³. Result: The 3,3 m³ bucket carries 3,5 m³.** For optimum stability always consult the bucket selection chart.

Material	Bucket fill %	Material density ton/m ³	ISO/SAE bucket volume, m ³	Actual volume, m ³
Earth/Clay	~ 110	~ 1,7	3,0	~ 3,3
		~ 1,5	3,3	~ 3,6
		~ 1,4	3,5	~ 3,8
Sand/Gravel	~ 105	~ 1,75	3,0	~ 3,2
		~ 1,65	3,3	~ 3,5
		~ 1,5	3,5	~ 3,7
Aggregate	~ 100	~ 1,9	3,0	~ 3,0
		~ 1,7	3,3	~ 3,3
		~ 1,6	3,5	~ 3,5
Rock	≤ 100	~ 1,8	3,0	~ 3,0

The volume handled varies with the bucket fill and is often greater than indicated by the bucket's ISO/SAE volume. The table shows optimum bucket choice with regard to the material density.

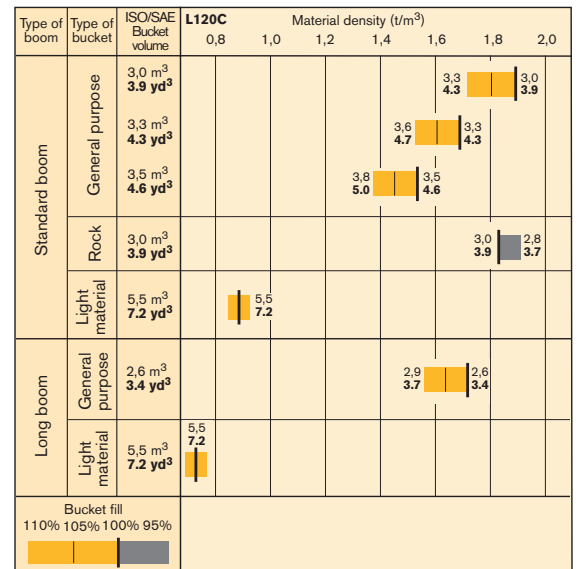

SUPPLEMENTAL OPERATING DATA

		excl. counterweight 1	Counterweight 2	Long Boom	
				Incl. / excl. counterweight 1	Counterweight 2
Operating weight	kg	-320	+680	-320	+680
Tipping load, full turn	kg	-550	+1 100	-480	+940

Counterweight 1 may be used in rehandling and material handling.

Counterweight 2 replaces hydroinflation of rear tires and must never be combined with tire chains.

Counterweight 2, and combinations of counterweight 1 and 2, may be used within pallet and material arms handling for stabilizing purposes on firm and level ground.

OPERATIONAL DATA & DIMENSIONS

TIRES: 23.5 R25* L2		
	STANDARD BOOM	LONG BOOM
B	6 510 mm	7 000 mm
C	3 200 mm	3 200 mm
D	440 mm	440 mm
F	3 400 mm	3 400 mm
G	2 135 mm	2 135 mm
J	3 800 mm	4 310 mm
K	4 100 mm	4 620 mm
O	54°	55°
P	45° (P max. 48°)	45°
R	42°	42°
R ₁ *	46°	46°
S	68°	64°
T	70 mm	130 mm
U	480 mm	610 mm
X	2 060 mm	2 060 mm
Y	2 680 mm	2 680 mm
Z	3 380 mm	3 800 mm
a ₂	5 730 mm	5 740 mm
a ₃	3 060 mm	3 060 mm
a ₄	±40°	±40°

* Carry position SAE

Where applicable, specifications and dimensions are in accordance with ISO 7131, SAE J732, ISO 7546, SAE J742, ISO 5998, SAE J818, ISO 8313.

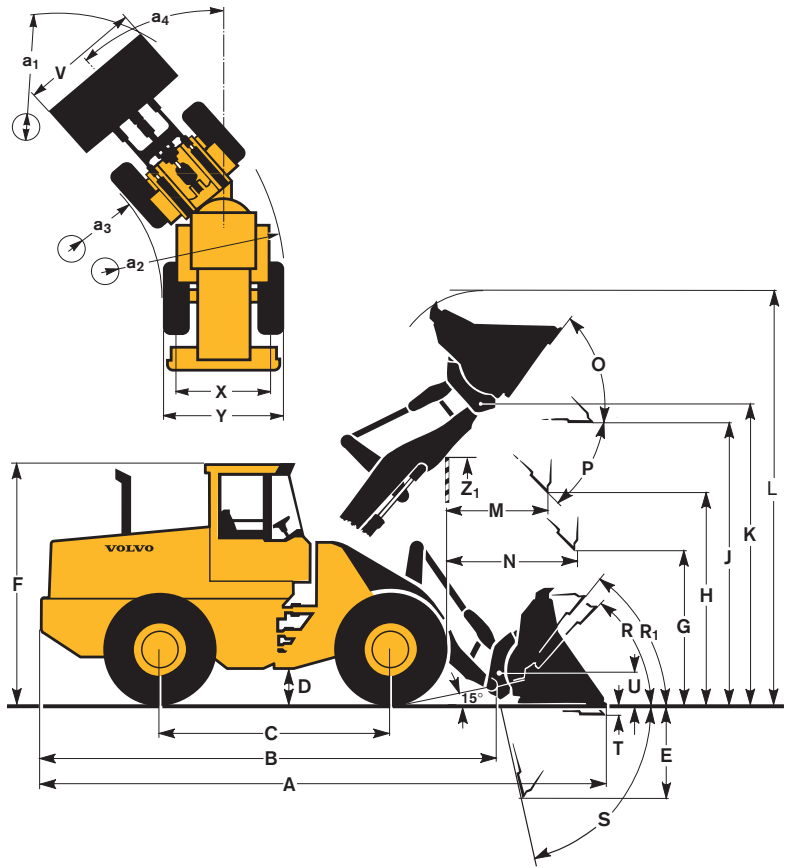

SORTING-GRAPPLE (Hook on)

A	2,4 m ²
B	3 560 mm
C	1 920 mm
D	2 920 mm
E	1 540 mm
F	1 550 mm
G	2 830 mm
H	4 730 mm
I	6 700 mm
J	2 750 mm
K	2 960 mm
L	2 110 mm
M	8 860 mm

Tires: 23.5 R25* L2
 Order No: 92 746
 Operating weight: 19 650 kg (incl. counterweight 1 & 2)
 Operating load: 6 400 kg (incl. counterweight 1 & 2)

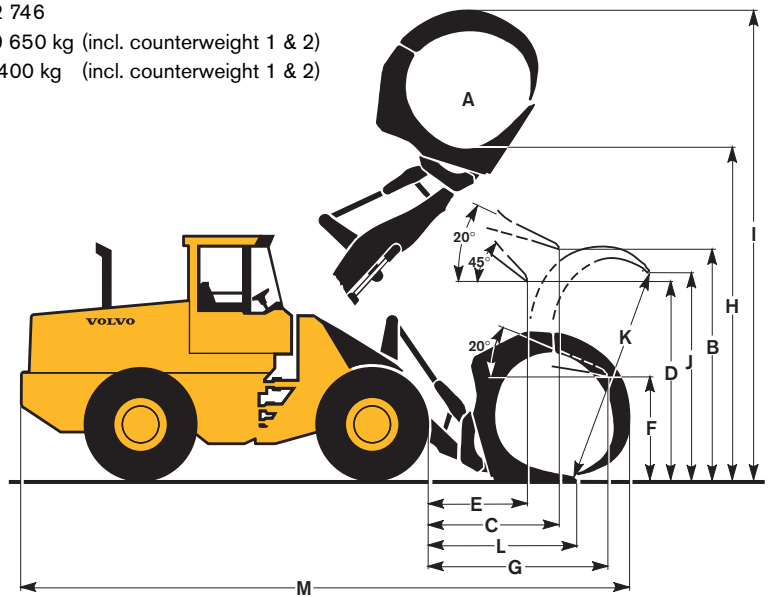



STEERING SYSTEM

Low-effort steering gives short work cycle times. Power-efficient system provides good fuel economy, good directional stability and smooth ride.

Steering system: Load-sensing hydrostatic articulated steering with power amplification.

System supply: The steering system is supplied from a separate steering pump.

Pump: Double variable-flow axial piston pump.

Cylinders: Two double-acting cylinders.

Steering cylinders	2
Bore	80 mm
Piston rod diameter	50 mm
Stroke	476 mm
Relief pressure	21 MPa
Max. flow	91 l / min
Articulation	± 40 °



CAB

Care Cab with easy entry and wide door opening. Lined with sound-absorbent material. Sound- and vibration-suppressing suspension. Good all round visibility, large glass areas. Curved windshield of laminated, green-tinted glass. Ergonomically located controls and instruments permit a comfortable operating position.

Instrumentation: All information important to the operator is readily visible in front of him. Cab display for Contronic monitoring system.

Heater and defroster: Heating element with filtered fresh air and four-speed fan. Defroster outlets for all windows.

Operator's seat: Spring suspended, adjustable operator's seat with belt. The seat is mounted on a bracket on the rear wall. The force from the belt is absorbed by the seat rails.

Standards: Tested and approved according to the following standards: ROPS (ISO/CD 3471, SAE J1040), FOPS (ISO 3449, SAE J231). Complies with "Overhead guards for rider lift trucks" (ISO 6055) and "Operator Restraint System" (SAE J386).

Emergency exits	2
Sound level in cab as per ISO 6396, max fan position	72 dB (A)
fan position 2	69 dB (A)
Ventilation	10 m ³ /min
Heating capacity	11 kW (37 500 Btu/h)
Air conditioning (optional)	8 kW (27 300 Btu/h)



HYDRAULIC SYSTEM

Open centre hydraulics with highly efficient vane pumps allows precision control even at low rpm's together with quick movements thanks to the high capacity pumps.

Pump: Vane pump fitted to a power take-off on the transmission. The pilot system is supplied from a combined pilot/brake pump which is mounted in series with the steering pump.

Valve: Double-acting 3-spool valve. The control valve is actuated by a 3-spool pilot valve.

Lift function: The valve has four functions: raise, hold, lower and float. Inductive/magnetic automatic boom kickout can be switched on and off and is adjustable to any position between maximum reach and full lift height.

Tilt function: The valve has three functions: rollback, hold and dump. Inductive/magnetic automatic bucket positioner that can be switched on and off.

Cylinders: Double-acting

Filter: Full-flow filtration through 20 µm (absolute) filter cartridge.

Vane pump	
Relief pressure	22,5 MPa
Flow	280 l/min
at	10 MPa
and engine speed	35 r/s (2 100 r/min)
Pilot system	
Relief pressure	3,0 MPa
Cycle times	
Raise*	5,8 s
Dump*	1,8 s
Lower, empty	2,8 s
Total cycle time	10,4 s

* with load as per ISO 5998 and SAE J818



LIFTARM SYSTEM

TP Linkage combines high breakout torque throughout the working range with nearly exact parallel lift-arm action. These features together with high lift height and long reach make the lift-arm system equally as good in bucket loading as in work with fork attachments and material handling arms.

Lift cylinder	2
Bore	160 mm
Piston rod diameter	80 mm
Stroke	676 mm
Tilt cylinder	1
Bore	230 mm
Piston rod diameter	110 mm
Stroke	412 mm

STANDARD EQUIPMENT

Engine

Air cleaner, dry type, dual element, exhaust aspirated pre-cleaner
Coolant level, sight gauge
Engine intake manifold preheater
Muffler, spark arresting

Electrical System

24 V – prewired for optional accessories
Alternator, 24 V, 60 A
Battery disconnect switch
Fuel gauge
Hourmeter
Horn, electric
Instrument panel with symbols
Lights:
• driving (2 front), halogen with high/low beam
• parking lights
• stop/tail combination (2 rear)
• turn signals with hazard warning switch
• working lights, halogen (2 front, 2 rear)
• instrument lighting
Contronic Monitoring System, ECU Neutral start feature
Test function for warning & monitoring lights

Warning & monitoring lights:

- engine oil pressure
- engine coolant temperature
- air cleaner restriction
- alternator malfunction
- working lights
- high beam driving lights
- direction indicator, hazard

Warning flasher:

- transmission oil pressure
- transmission oil temperature
- brake system pressure
- parking brake applied

Central warning (with buzzer):

- engine oil pressure
- engine coolant temperature (buzzer)
- transmission oil pressure
- transmission oil temperature
- brake system pressure

Drivetrain

Transmission: modulated with single lever control, Automatic Power Shift, and operator controlled declutch

Differentials:

- front 100 %, hydraulic differential lock
 - rear, conventional
- Tires 23.5 R-25* L2

Brake System

Wet, internal oil circulation cooled, disc brakes, 4-wheel, dual circuit
Brake system, secondary
Parking brake alarm

Cab

ROPS (SAE J10400C) (ISO 3471), FOPS (SAE J 231) (ISO 3449).
Acoustical lining
Ashtray
Cigarette lighter
Door lockable (left side access)
Heater/defroster/pressurizer 11 kW, 37 500 Btu/h with four speed blower fan
Filtered air
Floor mat
Interior light
Interior rearview mirror
Mirrors rearview (2), exterior
Openable window, right-hand side
Safety glass, tinted
Seat belt (SAE J386)
Seat, heated, ergonomically designed, suspension adjustable
Storage compartment
Sun visor
Windshield wiper, front & rear
Intermittent wiper, front
Cab access steps and handrails
Fenders, front & rear with anti-skid-tape

Hydraulic System

Main valve, 3-Spool, pilot operated
Pilot valve, 3-spool
Vane pump
Bucket lever detent
Bucket leveler, automatic with position indicator, adjustable
boom lever detents
Boom kickout, automatic, adjustable
Hydraulic control lever safety latch
Boom lowering system
Hydraulic pressure test ports, Quick connect
Hydraulic fluid level, sight gauge
Hydraulic oil cooler

External Equipment

Isolation mounts: cab, engine, gearbox
Lifting lugs
Side panels, engine hood
Steering frame lock
Vandalism lock, provision for: batteries, engine oil

OPTIONAL EQUIPMENT (May be standard in certain markets)

Service and maintenance equipment

Tool box
Tool kit
Air pressure equipment
Anti-freeze container
Wheel nut wrench kit

Engine

Coolant filter
Extra fuel filter
Cold starting aid, engine coolant preheater (220V/1500 W)
Pre-cleaner, oil bath type
Pre-cleaner, turbo type
Radiator, corrosion protected

Electrical System

Reverse alarm (SAE J994)
Attachment lights
Working lights front, extra
Working lights rear, extra
Rotating beacon, amber with collapsible mount
Alternator, brushless
Head lights assym. left
Jump-start connector (Nato)
Light, registration plate
Side marker lights
Contronic display

Shut down to idle at

- high engine coolant temp
 - low engine oil pressure
 - high transm. oil temp
- Parking brake applied and transmission in forward or reverse (buzzer)

Drivetrain

Forward and reverse switch
Speed limiter, 3-speed version
Limited-slip differentials, front/rear

Cab

Installation kit for radio
Hand throttle
Sliding ventilation window
Speedometer
Air suspended operator's seat
Retractable seat belt
Air conditioner 8 kW, 27 300 Btu/h
Dual service brake pedals
Armrest (left)
Contronic display
Cab filter for asbestos contaminated environment
Instructor seat
Noise reduction kit, cab
Steering wheel, adjustable tilt, telescopic
Windshield washer, front & rear

Hydraulic System

Hydraulic control, 3rd function
Hydraulic control, 4th function
Hydraulic single acting lifting function
Boom Suspension System
Biodegradable hydraulic fluid
Hydraulic function 3rd, hydraulic hoses
Servo hoses for separate attachment locking
Attachment bracket with separate locking system

External Equipment

Fenders, extended
Counterweight 1
Counterweight 2
Fenders, axle mounted
Drawbar with pin

Other Equipment

Comfort Drive Control (CDC)
Slow moving vehicle emblem
Secondary steering
50 km/h sign
Fuel fill strainer
Long Boom

Tires

23.5-25
23.5 R25*

Protective Equipment

Protective grids for front running light
Protection guard radiator grille
Protective grids for rear working lights
Window guards for side and rear window
Windshield guard
Fan protection
Protective grids for rear lights
Bellyguard rear

Attachments

Buckets
Fork equipment
Material handling arm
Timber grapples
Diagonal snow blade
Broom
Cutting edge, 3 pc reversible, bolt-on
Bucket teeth, bolt-on
Bucket spillguard
Bale clamp
Drum rotator

Under our policy of continuous product improvement, we reserve the right to change specifications and design without prior notice. The illustrations do not necessarily show the standard version of the machine.

VOLVO

Volvo Construction Equipment Group

Ref. No. 21 3 669 2263
Printed in Sweden 98.03 – 5,0

English
WLO

Courtesy of Machine.Market