

VOLVO COMPACT WHEEL LOADERS
L20B, L25B



MORE CARE. BUILT IN.



Courtesy of Machine.Market

DESIGNED FOR MANY HOURS OF EFFICIENT WORK.

There is no need to make a compromise between size and performance with Volvo L20B, L25B and Z-bar linkage L25B Z wheeled loaders. Ideally suited to operation in confined spaces, these compact loaders match a spacious, quiet and comfortable cab with rugged build and parallel lift for outstanding productivity.

Getting into and out of the loader is safe and comfortable. Two solid grab handles grant a firm hold when climbing the single step taking you to the cab. You pass the wide doorway, and you are entering a working place made to measure any operator. In spite of the compact exterior dimensions of the machine, the interior of the cabin is roomy and spacious. Enough head room and a multiple adjustable operator's seat ensure that even tall operators will immediately feel at home. A practical holder at the back of the operator's seat keeps beverage and mobile phone well at hand, while personal things can be stored in the compartment incorporated into the arm rest. An efficient three stage heating and ventilation system with filter and well positioned air distribution provides a pleasant working climate in the cab.

You will soon find the benefits of the new corner position of the dash-board. It combines the advantage of an undisturbed front view and at the same time it allows an easy monitoring of the main machine functions as it is within the operator's field of vision. The layout of the dashboard and controls is simple and functional. A clearly arranged combination of analogue indicator elements and warning lights provide all the information the operator requires.

All pedals, levers and controls are laid out for ease of operation. Control of direction and of the hydraulic functions including the 100% differential locks are affected via the multi-function lever. The inch brake pedal allows permanent speed adjustment and safe braking without changing to another pedal.

Great attention has been paid to safety. The machine offers good stability thanks to the rear wrap-around counterweight, the cab is designed according to ROPS/FOPS safety standards. The rounded rear end of the machine and the large glazed surface areas surrounding the cab provide excellent all-round visibility, improving safety at work.



- Easy entry/exit.

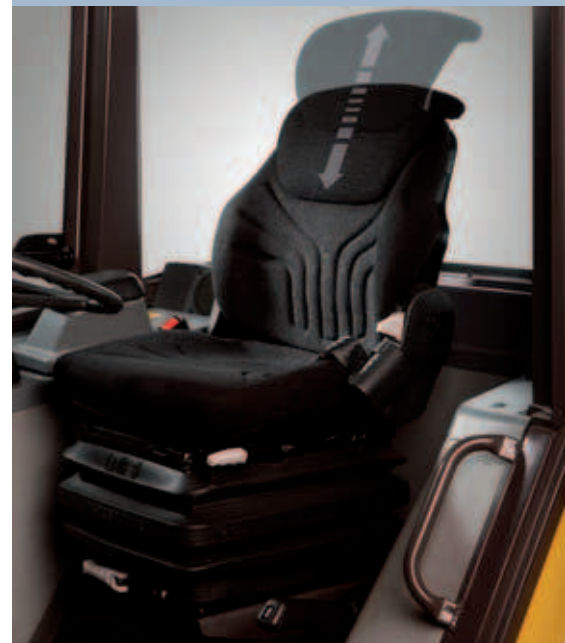

- Adjustable sprung seat to suit each operator.



- Protected open door.



- Ergonomic function lever.
- Ideally positioned pedals.
- Efficient climate control.



- Well thought-out ergonomic cabin.
- Simple sturdy door.

SMALL IN SIZE - GREAT IN PERFORMANCE.

Working on narrow sites calls for limitations in size, not in productivity. With regards to this, the L20B and L25B leave nothing to be desired. They are reliable, stable and are made for demonstrating their extraordinary performance in areas which are not accessible with other machines.

Compactness at its best, what is unique about the compactness of an L20B is the possibility of managing passages with a vertical clearance as low as 2,5 m. To access the interior of buildings it is even possible to remove and then replace the removable cab.

Like every Volvo Compact wheel loader, the L20B and L25B is an expert in mobility. Thanks to the well-positioned wrap around counterweight and the articulating oscillating joint it is extremely stable even on rough terrain. The 100% operator selectable differential lock, which is standard on both axles allow the machine to manoeuvre on all ground conditions with optimum traction on difficult ground and low ground pressure on delicate surfaces.

Both the L20B and L25B have the Volvo attachment bracket which allows one of more than 60 different attachments to be fitted to the machine within a few seconds and without the driver having to leave the comfort of the operator's cab. A skid steer attachment bracket is available for the L20B and L25B P to further enhance versatility.

Regarding performance these small machines are a real surprise. With respective lift capacities of 1.8, 2.1 and to 2.0 tons, the L20B, L25B P and Z-bar L25B Z are small but powerful. The same is true for the lift height. The linkage reaches important lifting positions allowing even the loading of four axle trucks and has unrivalled reach due to the design of the parallel loader linkage. The Volvo parallel- and the Z-bar loader linkage automatically keep the load level as it is raised and lowered.

State of the art technology gives you the best possible output. A powerful Volvo engine at the core of the system supplies ample power. Smooth Working Cycles are assured due to the dual circuit hydraulic system with separate pumps for working and steering hydraulics, this ensures total independence of movements, which contributes to the smoothness of working cycles.



- Outstanding manoeuvrability even in difficult situations.



- Optimum lifting height, fast cycle times.



- Independent working hydraulic pumps.



- Excellent dump height.

Courtesy of Machine.Market

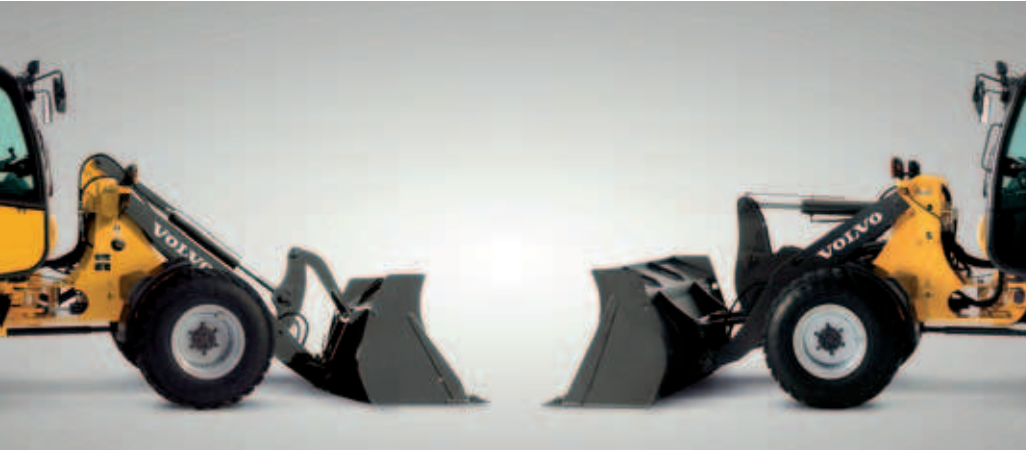

- Versatility of L25B with a choice of either parallel or Z-bar linkage.
- Compact dimensions allowing access to otherwise unreachable sites.



- The optional skid steer attachment bracket allows many skid steer attachments to be used.
- Time saving and convenient Volvo attachment bracket.

EASY MAINTENANCE AND TOP ECONOMY.

Like all Volvo's, the L20B, L25B have been designed with full knowledge of the daily requirements on site. In this respect simple servicing is one of the major points, just as from the economical point of view. Simple service is the best guarantee for regular maintenance, which is an absolute must for maintaining an optimum machine function and a maximum residual value for the future.

Great attention has been drawn to the fact of making the L20B and L25B as service friendly as possible. All main components and service checkpoints are located under the large engine hood. Filters and battery are easily exchangeable. The tank's filler is wide enough to make refilling possible directly from the fuel can. Easily accessible lubrication points on the articulating oscillating joint make greasing a simple task.

Daily service checks can be executed within a very short time. The dipstick for the engine oil level is easily to reach, sight glasses advise on hydraulic oil levels at a glance, hydraulic pressure and engine status can be monitored by warning lights on the dashboard. For easy checking of safety fuses and relays a complete modular electric board is centrally mounted and accessed by opening a separate lid on the right side of the machine.

High Quality Components. All efforts have been taken to supply you with a machine to serve you many hard working hours throughout a long, reliable service life. You can be sure that only high quality materials and components have been used in the production process.

Large dimensioned sealed bearings on linkage and articulating oscillating joint ensure minimized wear. A standard water separator in the fuel system ensures a long service life of the high pressure elements in the engine.

Good news for the service personnel. They will appreciate that the service intervals for long term service have been considerably prolonged on the L20B and L25B, which saves time and money.

A Volvo Compact Wheel Loader is a sound investment - for several reasons. The main reason is its price/performance ratio. Another economical plus is the fact that a Volvo compact wheel loader encompasses several machines in one. With use of its interchangeable attachments you can convert it to your needs, keeping downtime to a minimum. No matter what the task may be, there will always be a job for your Volvo.

Competent Supplier Support, when purchasing a Volvo you can take advantage of the wide spread Volvo dealer network. Their concern is to give you every support you need to do a good job. They can offer you a comprehensive range of construction related equipment and are always ready to help you with advice on applications, technical support, and after sales service. Ask your local dealer about the comprehensive Volvo financial service or about special offers suitable for you. Moreover, you can also count on Volvo in case of an emergency. An elaborated system will help to supply you with the genuine Volvo parts you require, delivered as quickly as possible to keep your downtime as short as possible.



- Easy air filter change.



- Easy fuel filling, even directly from a fuel can without spout of funnel.



- Easy service of articulating/oscillating joint.



- Easy access to the hydraulic pumps.

Courtesy of Machine.Market



- Reliability and performance - year after year for increased resale value.
- Fast and easy maintenance check.



- Easy access electrical components.



SPECIFICATIONS

Engine

Volvo in-line 4-cylinder, 4 stroke, direct injection diesel engine, oil/air cooled. Air cleaning: 1. Paper filter with indicator in cab. 2. Safety filter. Compliant to EPA Tier 3/EU Stage IIIA environmental regulations.

	L20B	L25B/L25B Z
Engine	D3.6D	D3.6D
Gross power @	2300 r/min	2300 r/min
SAE J1995	41.0 kW - 55.8 hp	43.1 kW - 58.6 hp
Net power @	2300 r/min	2300 r/min
SAE J1349 - DIN ISO 1585	39.9 kW - 54.3 hp	42 kW - 57.1 hp
Max torque @	1600 r/min	1600 r/min
SAE J1349 net - DIN ISO 1585	180 Nm	190 Nm
DIN ISO 1585	180 Nm	190 Nm
Cubic capacity	3620 cm ³	3620 cm ³
Bore	96 mm	96 mm
Stroke	125 mm	125 mm

Electrical system

	L20B	L25B/L25B Z
Voltage/Battery capacity	12 V - 88 Ah	12 V - 88 Ah
Alternator rating	1120 - 80 W/A	1120 - 80 W/A
Starter motor output	2.2 kW	2.2 kW

Drivetrain

	L20B	L25B/L25B Z
Oscillation at wheel, max.	226 mm	245 mm
Track	1300 mm	1410 mm
Angle of oscillation	±10°	±10°

	L20B	L25B P	L25B Z
Tyre:			
Size	120-R18	125-R18	335/80-R18
Rim	11 x 18	11 x 18	11 x 18

Maximum speed

1st range forward/reverse	4.5 km/h	5 km/h
2nd range forward/reverse	20 km/h	20 km/h

Brake system

Service brake: reliable dual braking system, acting upon all four wheels.

Steering system

Hydrostatic steering. Central articulating-oscillating joint.

Steering pump: gear-type pump.

Steering:

	L20B	L25B/L25B Z
Angle of articulation	±38°	±38°

Steering system

Steering pump:

	L20B	L25B/L25B Z
Flow @ engine r/min	25 l/min - 2300 r/min	25 l/min - 2300 r/min
Relief valve pressure	18.5 MPa	18.5 MPa

Cab

Instrumentation: All important information is located in the operator's field of vision.

Hydraulic system

Thermostatically controlled oil circuit with integrated cooling system. Hydraulic control valve: double acting control valve with three spool system.

	L20B	L25B/L25B Z
Control	Control valve three-spool system.	

3rd hydraulic circuit

Flow @ engine r/min	55 l/min - 2300 r/min	55 l/min - 2300 r/min
Relief valve pressure	20 MPa	23 MPa

Linkage

Parallel linkage with high breakout force and exact parallel liftarm action.

	L20B/L25B	L25B Z
Lift cylinders / Tilt cylinders	1/1	2/1
Lift time (loaded)	6.0 s	6.5 s
Lowering time (empty)	4.0 s	4.0 s
Dump time	2.0 s	1.5 s
Crowd time	1.5 s	2.0 s

Capacities

	L20B	L25B/L25B Z
Engine	11.8 l	11.8 l
Fuel tank	60.0 l	60.0 l
Front axle	4.1 l	4.1 l
Rear axle, incl. drop-box	5.8 l	5.8 l
Hydraulic tank, incl. hydraulic system	60.0 l	60.0 l

Noise levels

The L20B conforms to the 2006 European Machine Directive Noise Level (2000/14/CE) of 99 dB(A) for this class of machine.

The L25B conforms to the 2006 European Machine Directive Noise Level (2000/14/CE) of 99 dB(A) for this class of machine.

SPECIFICATIONS - L20B

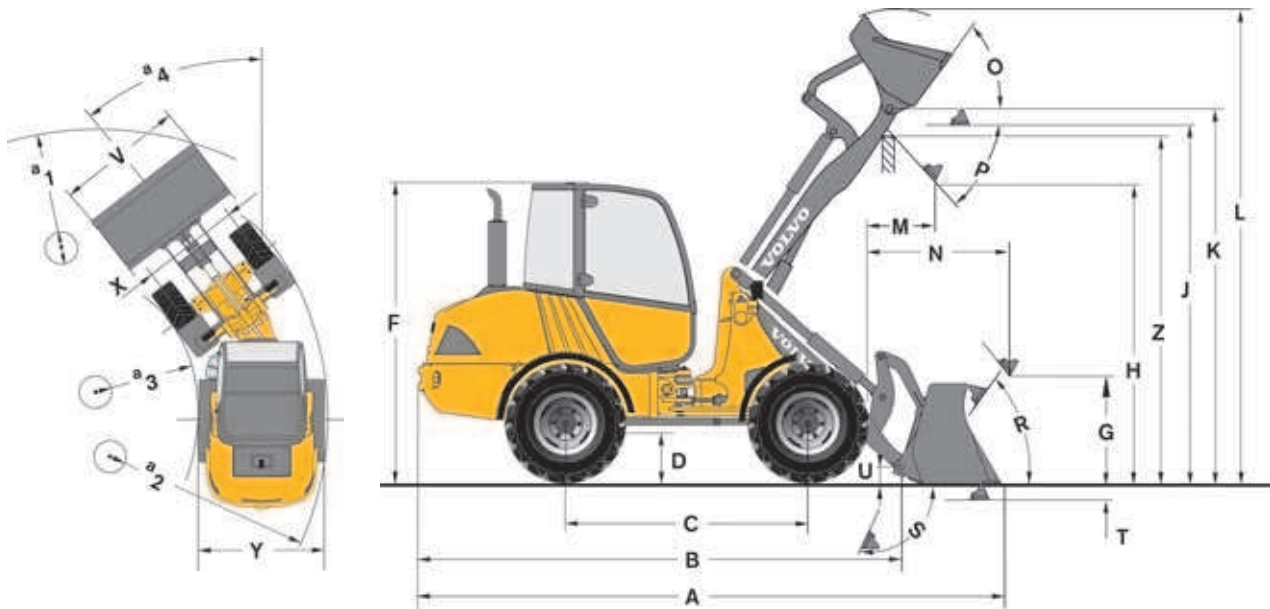

Data according to bucket type		General Purpose		Light material	4 in 1	High-Tip
L20B with parallel-linkage, Z-attachment carrier and 12.0-18 tyres.						
Capacity heaped	m ³	0.7	0.85	1.0	0.65	1.1
Material density	kg/m ³	1900	1600	1400	1900	1000
Static tipping load, straight (ISO / DIS)	kg	3250	3200	3150	3000	2500
Static tipping load, full turn 38° (ISO / DIS)	kg	2900	2850	2800	2650	2250
Hydraulic lifting capacity, max.	kN	35.0	34.0	33.5	32.5	28.0
Breakout force	kN	35.0	30.5	28.0	36.5	-
A Total length	mm	5035	5135	5195	5005	5510
L Lift height, max.	mm	4060	4140	4190	4070	4890
V Bucket width	mm	1650	1650	1800	1650	1800
a ₁ Clearance circle	mm	8210	8260	8430	8220	8620
T Digging depth	mm	120	120	120	160	120
H Dump height	mm	2510	2435	2395	2480	3540
M Reach at max. height	mm	660	720	765	575	1005
N Reach, max.	mm	1475	1535	1580	1390	2140
Operating weight	kg	4300	4330	4340	4460	4670

L20B with parallel-linkage, Z-attachment carrier and 12.0-18 tyres	
B	4275 mm
C	2050 mm
D	300 mm
F	2450 mm
G	875 mm
J	2980 mm
K	3125 mm
O	56°
P	45°
R	56°
S	65°
U	145 mm
X	1300 mm
Y	1625 mm
Z	2885 mm
a ₂	3830 mm
a ₃	2160 mm
a ₄	±38°

Data with loading fork		
Centre of gravity 500 mm		
Tipping load, full turn (ISO / DIS)	kg	2290
Payload according to EN 474-3, 60/80%	kg	1350/1800
Payload 80%, transport position, 38° full turn	kg	2200

SPECIFICATIONS - L25B Z

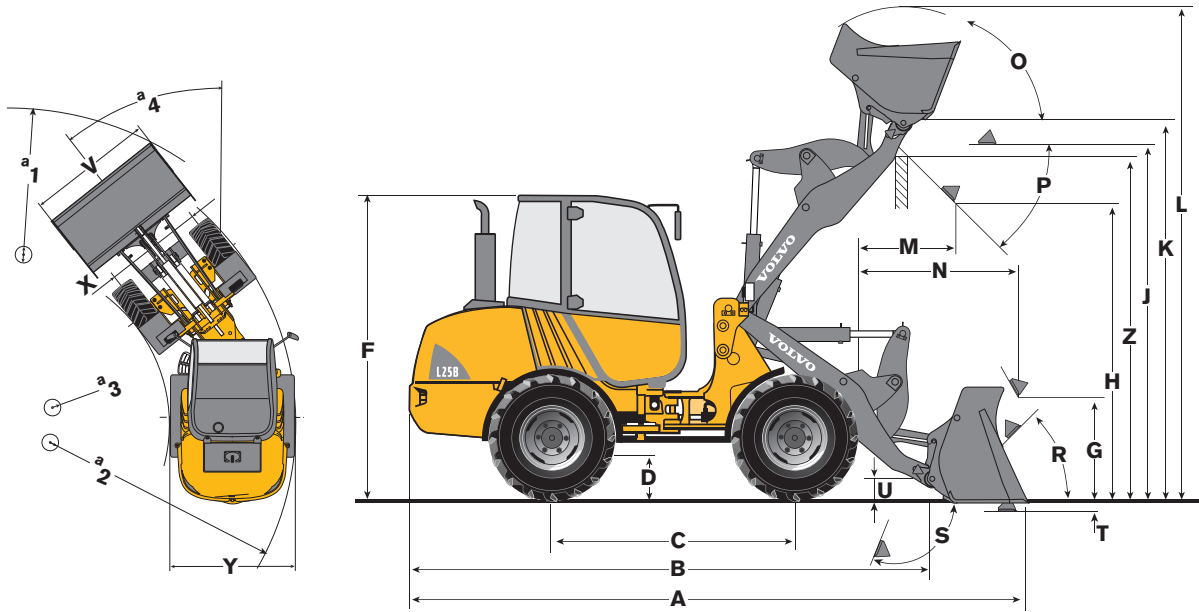

Data according to bucket type		General Purpose		Light material		4 in 1	High-Tip
L25B Z with Z-linkage, Z-attachment carrier and 335/80 R18 tyres.							
Capacity heaped	m ³	0.9	1.0	1.2	1.4	0.8	1.2
Material density	kg/m ³	1800	1600	1300	1100	1800	1100
Static tipping load, straight (ISO / DIS)	kg	3615	3570	3475	3425	3300	3100
Static tipping load, full turn 38° (ISO / DIS)	kg	3255	3215	3125	3085	2975	2795
Hydraulic lifting capacity, max.	kN	55.0	54.2	52.8	52.0	51.5	48.0
Breakout force	kN	54.5	47.5	42.0	42.0	51.5	-
A Total length	mm	5265	5365	5470	5470	5305	5620
L Lift height, max.	mm	4135	4175	4265	4265	4050	4950
V Bucket width	mm	1800	1800	1800	2000	1800	1900
a ₁ Clearance circle	mm	8650	8710	8775	8960	8675	8960
T Digging depth	mm	100	100	100	100	105	100
H Dump height	mm	2500	2420	2345	2345	2440	3610
M Reach at max. height	mm	745	815	885	885	730	955
N Reach, max.	mm	1525	1595	1665	1665	1510	2125
Operating weight	kg	4800	4800	4850	4880	4890	5100

L25B Z with z-bar linkage, Z-attachment carrier and 335/80 R18 tyres	
B	4470 mm
C	2125 mm
D	310 mm
F	2470 mm
G	850 mm
J	2970 mm
K	3170 mm
O	70°
P	45°
R	50°
S	96°
U	200 mm
X	1410 mm
Y	1740 mm
Z	2880 mm
a ₂	3935 mm
a ₃	2155 mm
a ₄	±38°

Data with loading fork			
Centre of gravity 500 mm			
Tipping load, full turn (ISO / DIS)	kg	2500	
Payload according to EN 474-3, 60/80%	kg	1500/2000	
Payload 80%, transport position, 38° full turn	kg	2400	

STANDARD EQUIPMENT

Engine

Diesel engine, direct fuel injection.
Extra fuel filter.
Cold start aid.
Dry-type air filter.

Electrical system

Alternator 80 A.

Lighting

Main head lights (halogen)
full/dipped/asymmetrical.
Working light (rear right).
Parking lights.
Rear lights.
Brake lights.
Direction indicators.
Hazard warning lights.
Cab lighting.

Instrumentation & controls

Multi-function lever.
12 Volt accessories socket.
Horn.
Hazard warning switch.
Safety start.
Analogue information for:
Fuel level
Operating hours.
Illuminated symbols for:
Differential locks
Battery charging
Indicators (left/right)
Main beam
Pre-heater
Direction (forward/reverse)

Travel (quick, slow)
Fuel level.
Illuminated symbols with acoustic signal
(with ignition on) for:
Engine temperature
Engine oil pressure
Hydraulic oil temperature
Hydraulic oil filter
Air filter restriction
Parking brake.

Drivetrain

Hydrostatic drive.
Operator-selected 100% differential locks.
Tyres :
L20B P : 12.0/80 R18
L25B P : 12.5/80 R18
L25B Z : 335/80 R18

Cab Exterior

Removable ROPS/FOPS-cab with flexible
mountings.
Lockable door.
All-round tinted safety glass.
Windscreen wiper (front/rear).
Windscreen washer (front/rear).
Openable window on the right side.
Door stops.
External rear view mirrors (right/left).

Cab Interior

4-way adjustable operator's seat.
Seat belt.
Sunvisor.
Heater with air-filter and defroster (front/rear)
Cab ventilation.
Storage box in cab.

Hydraulic system

Gear-type pump.
Control valve three-spool system.
3rd hydraulic circuit.

Working Equipment

Hydraulic quick-change attachment carrier.

Carriage Body

Fenders (front/rear).
Lockable engine hood.
Vertical exhaust.
Towing device.
Lifting eyes.

International Standards for Machines and Production

Quality: DIN/ISO 9001.
Safety: CE - Criteron.
Machine guide-lines 98/37/EC.
ROPS ISO 3471.
FOPS ISO 3449.
Operating weight: ISO 7131.
Tipping load / Payload: ISO / DIS 14397-1.
EMV (Electromagnetic Compatibility).
89/336/EEC plus supplement Environment:
DIN/ISO 14001.
Sound regulation: 2000/14/EC.
German environmental seal "low noise"
RAL - UZ 53".

OPTIONAL EQUIPMENT (Standard on certain markets)

Engine equipment

Pre-heater.
Pre cleaner air filter (Turbo II).
Oilbath air filter.
Exhaust particle filter.

Cab

Handthrottle.
Hand control inch valve.
Airconditioner.
Radio.

Working lights (2 front/1 rear left).
Air suspension operator's seat.

Working Equipment

Bucket level indicator (standard for L25B Z).

Hydraulic system

Hydraulic couplings for:
3rd hydraulic circuit.
4th hydraulic circuit.
Additional pump.

Environment

Biodegradable hydraulic oil.

Safety

Anti-theft system.
Protective guards for:
Main head lights
Working lights
Rear lights.
Rotating beacon.
Audible reverse alarm.

Service and maintenance

Tool kit.

ATTACHMENTS

A small selection of the most popular
attachments:
Bucket
Loading Fork

4-in-1 Bucket
Material Handling Arm
Sweeper
Side-Tip Bucket
High-Tip Bucket

Hay/Manure Fork
Snow Plough
Further buckets and attachments available on
request.

SPECIFICATIONS - L25B

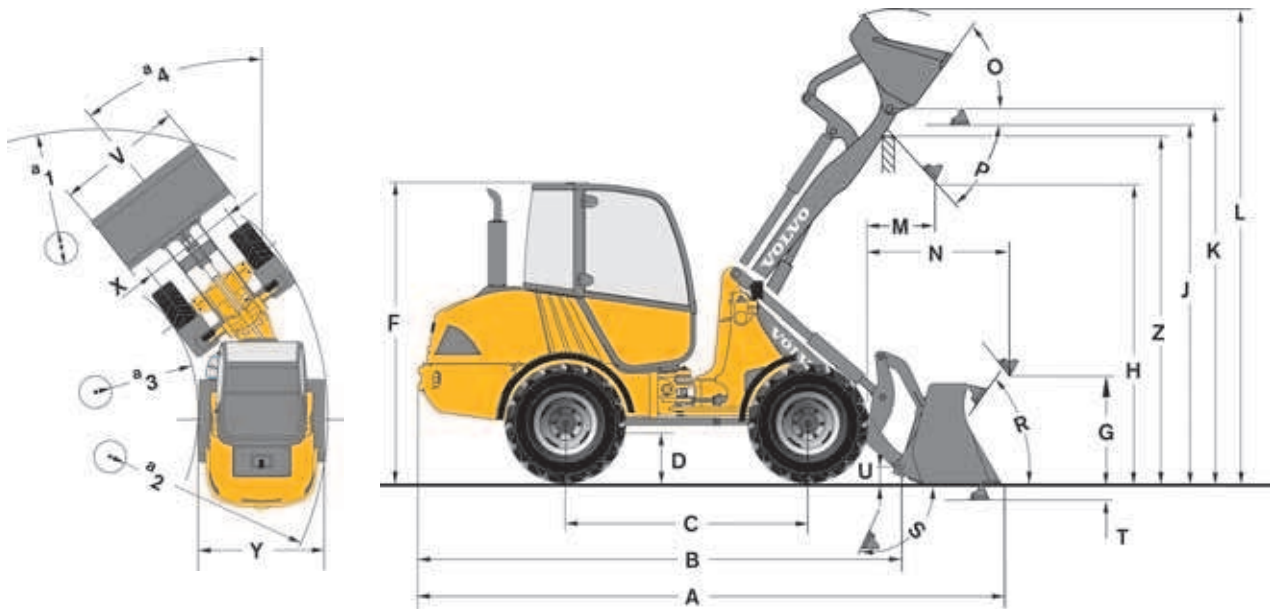

Data according to bucket type		General Purpose		Light material	4 in 1	High-Tip
L25B P with parallel-linkage, Z-attachment carrier and 12.5-18 tyres.						
Capacity heaped	m ³	0.85	1.0	1.2	0.8	1.1
Material density	kg/m ³	1900	1600	1300	1800	1200
Static tipping load, straight (ISO / DIS)	kg	3800	3750	3700	3400	3100
Static tipping load, full turn 38° (ISO / DIS)	kg	3400	3350	3300	3050	2800
Hydraulic lifting capacity, max.	kN	41.0	40.2	39.5	37.8	34.0
Breakout force	kN	37.0	32.5	29.0	35.7	-
A Total length	mm	5085	5185	5285	5110	5500
L Lift height, max.	mm	4100	4195	4290	4085	4890
V Bucket width	mm	1800	1800	1800	1800	1800
a ₁ Clearance circle	mm	8370	8425	8480	8405	8610
T Digging depth	mm	105	105	105	145	105
H Dump height	mm	2480	2410	2340	2410	3550
M Reach at max. height	mm	675	745	815	635	985
N Reach, max.	mm	1495	1560	1635	1455	2115
Operating weight	kg	4800	4830	4860	5010	5140

L25B with parallel-linkage, Z-attachment carrier and 12.5-18 tyres	
B	4265 mm
C	2050 mm
D	320 mm
F	2475 mm
G	840 mm
J	2990 mm
K	3140 mm
O	56°
P	45°
R	54°
S	65°
U	145 mm
X	1410 mm
Y	1735 mm
Z	2895 mm
a ₂	3880 mm
a ₃	2100 mm
a ₄	±38°

Data with loading fork		
Centre of gravity 500 mm		
Tipping load, full turn (ISO / DIS)	kg	2670
Payload according to EN 474-3, 60/80%	kg	1600/2100
Payload 80%, transport position, 38° full turn	kg	2500



Volvo Construction Equipment is different. It's designed, built and supported in a different way. That difference comes from an engineering heritage of over 170 years. A heritage of thinking first about the people who actually use the machines. About how to help them be safer, more comfortable, more productive. About the environment we all share. The result of that thinking is a growing range of machines and a global support network dedicated to helping you do more. People around the world are proud to use Volvo. And we're proud of what makes Volvo different – **More care. Built in.**



All products are not available in all markets. Under our policy of continuous improvement, we reserve the right to change specifications and design without prior notice. The illustrations do not necessarily show the standard version of the machine.

VOLVO

Construction Equipment

www.volvoce.com

Ref. No. 21 5 430 5591
Printed in Sweden
Volvo, Belley

English
2008.05
CWL

Courtesy of Machine.Market