

VOLVO WHEEL LOADERS
L20F, L25F



MORE CARE. BUILT IN.



Courtesy of Machine.Market

ON TO YOUR NEXT PERFORMANCE.

The Volvo L20F and L25F compact wheel loaders are built to give your productivity a needed lift. The right power. The right performance. It's something you can depend on every day, no matter what the day's jobs have in store for you. Lifting, loading and moving swiftly, Volvo is ready to perform.

Performance to move you

Powerful Volvo D3D 4-cylinder diesel engine provides excellent overall performance.

- Outstanding operating weight-to-load capacity ratings.
- Natural aspiration air/oil cooled.
- Self-bleeding fuel system gets rid of unwanted air if you run out of fuel.
- Complies with EU Stage IIIA and EPA Tier 3 standards for quiet, low emission operation.

Choice of boom concept for L25F

Choose from either the **parallel linkage**:

- Excellent visibility for attachments, forks and buckets.
- Ensures optimum lifting height and reach during high truck loading.
- 100% parallelism of the loading fork.
- Easy to operate. Versatile.

Or the **Z-bar linkage**:

- Excellent parallelism of the fork along the entire lifting range.
- High breakout force.
- Large roll-back and dump angle.
- Attachment compatibility for: L30B/L35B/ZL502/ZL602

The right size

The compact design with machine height below 2500 mm provides easy access to confining work spaces, such as urban areas.

The right speed

Hand inch valve allows operators to adapt travel speed to the application.

- Independent from the drive pedal position.
- Precise drive speed control for special applications.

Maximize attachment use

Optional attachment bracket works with skid steer loader and L30B attachments for increased productivity and versatility.



- High-performance, 4-cylinder Volvo diesel engine.



- Attachment bracket lets you use more attachments.



- Compact design makes it easy to get in and out.



- It's your choice on L25F: Z-bar or parallel linkage.
- Powerful Volvo D3D 4-cylinder diesel engine provides excellent overall performance.



IMPROVE YOUR EFFICIENCY. START HERE.

One of the keys to profitability is efficiency. Do it better, faster and much more efficiently with Volvo L20F and L25F wheel loaders. It starts with standard, 100% operator-selectable differential locks on the front and rear axle. All wheels turn with the same speed for optimum traction – to help you do the job economically.

Work at your speed

Independent gear pumps for working hydraulics and steering.

- Improves cycle times. Quick steering actions have no influence on lift arm speed.
- No engine rpm increase required. The optional hand throttle sets and locks engine speed at a desired rpm level.
- Efficiently match engine rpm to the application.
- Improved fuel efficiency and cost control.
- Located for ease of use beneath the operator's seat.

A well-articulated concept

Frame concept features an articulating/oscillating center joint for operator comfort and stability.

- Control and compensation when operating on uneven terrain.
- Large, sealed bearings/bushings and surface-hardened pins for long life.
- Maximum agility and efficient power distribution to all wheels.

Get attached – and go

The well-designed boom linkage system and attachment bracket makes for easy attachment monitoring.

- Good attachment visibility to help reduce risk of damage.

Standard third hydraulic circuit for the attachment bracket along with two additional quick connectors.

- Reduced cost for additional hydraulic functions.

A moveable force

High breakout force and lifting capacity to efficiently handle more work.



- Get more done with the third hydraulic circuit.



- A good view makes attachment monitoring easy.



- Separate working and steering hydraulic pumps.



- The breakout force and lift capacity you need.



- The articulating/oscillating joint keeps it stable.



- 100% operator-selectable front/rear differential locks.



MORE COMFORT TO GET MORE DONE.

You work long shifts. Most of it is spent inside your cab. That's why the Volvo L20F and L25F feature a comfortable operator station. Among the most spacious in its category, the Volvo Care Cab is designed to help you get the most productivity out of each day – no matter how long.

Excellent all-around visibility

The cab features a very large glazed surface area on all four sides of the machine.

- Excellent visibility for improved jobsite safety.
- Increased view to the attachments for faster, safer work.

You are in control

Conveniently-located central dashboard keeps all function controls within easy view.

- Control lights/indicators include: differential lock, hydraulic oil filter, hydraulic oil temperature, battery charge, air filter, engine oil pressure, engine oil temperature, handbrake, preheating, forward/reverse direction, machine speed, fuel gauge, hour meter.

The ergonomic, multi-function joystick lever makes handling of machine controls effortless.

- Lift, lower, float, tilting forward and backward, forward, neutral, reverse, differential locks.

Work in comfort

The fully-adjustable seat can be suited to each operator.

- Adjust: the amount of seat spring, seat forward/rearward, seat back angle.
- More comfort and less fatigue for more productivity.

Heating, demisting and de-frosting ensures clear visibility and comfort in all climates.

- New heavy-duty, 3-step heating blower.
- Efficient heating for all windows and throughout the cab, including foot areas.

Less operating fatigue

Optional adjustable steering column reduces operator fatigue for improved productivity.

Cab sound proofing provides a safer, quieter operating environment.



- Fully-adjustable seat suits each operator.



- Multi-function joystick for ease of control.



- Excellent all-around visibility.



- Dashboard shows all the information you need.
- There's plenty of comfort in the spacious cab.



- Clear comfort with heating, demisting & de-frosting.

LOADED WITH FEATURES.

Full cab filtration

- With the windows closed, the operator can breathe filtered air for safe operation in dusty conditions.

Volvo Care Cab

- Safe, quiet and comfortable, the Volvo cab offers excellent all-around visibility.

Parallel linkage

- Excellent attachment visibility and optimum lifting height and reach.

Optional Z-bar linkage for L25F

- Large roll-back and dump angle along with excellent fork parallelism and high breakout force.

Maximize attachments use

- Optional attachment bracket increases productivity by working with attachments from other machines.





See more, do more

- Extra bright cab work lights provide extra illumination in low light.

Powerful Volvo engine

- Outstanding overall performance with emission compliance.

100% locking differentials

- Both front and rear axles have fully-locking differentials.

Excellent stability

- Articulating/oscillating center joint delivers excellent stability and

MORE WORK. LESS SERVICE. KEEP ON WORKING.

Get started and get to work – faster, each day. That's because it's quick and easy to perform your daily service. Everything is in reach. Check it. Fill it. And then get to it. Once you're out there, the Volvo L20F and L25F will help keep you working safely. Down to the bucket and over your shoulder, the view from Volvo is where you want to be.

It's all right there

Access to the main service points is quick, easy and fully protected under the engine hood.

- All within easy reach: radiator, battery, engine oil filters, air filters, hydraulic filter.

All electrical components are located in a safe, protected and easily-accessible location.

- LED-controlled relays and fuses make troubleshooting fast.
- Fuses and relays are easily exchangeable.

A safe cab

Enter and exit the cab safely and easily with large, low grab handles and a single step.

- Makes frequent trips in/out of the cab fast and safe with three points of contact.

The rounded, compact-designed engine hood provides good visibility to the rear, making backing up easier and safer.

- Improved safety for people and property around the machine.

Cab and canopy are ROPS/FOPS safety certified.

- Provides optimum operator safety in case of roll-over or falling objects.
- Canopy version provides a safe, value option.

The view from here

Lowering the left and right hand base line of the front windscreen provides good visibility to the front wheels.

- Safe, precise operation, even in restricted work areas.

Fully-opening side window, located inside the frame edge, can be locked in the open position.

- Easy to open and close from the operator's seat, providing extra cab ventilation.

It's secure

For vandal protection and ease of operator use, a single key opens all the machine's locks.

- One key opens: cab door, engine cover lock, tool box in cab.

Fully-opening door is within the contour of the machine and can be safely secured in the open position.

- Provides excellent visibility and ventilation.



- Safe and easy cab access.



- Fully-opening side window provides good ventilation.



- Rounded engine hood for good rear visibility.



- See more from the large front windscreen.



- Genuine Volvo parts protect your investment.
- Easy service access.



SPECIFICATIONS

Engine

Volvo in-line 4-cylinder, 4 stroke, direct injection diesel engine, oil/air cooled. Air cleaning: 1. Paper filter with indicator in cab. 2. Safety filter. Compliant to Tier III / Stage 3A environmental regulations.

	L20F	L25F
Engine	D3.6D	D3.6D
Gross power @	2300 r/min	2300 r/min
SAE J1995	41.0 kW - 55.8 hp	43.1 kW - 58.6 hp
Net power @	2300 r/min	2300 r/min
SAE J1349 - DIN ISO 1585	39.9 kW - 54.3 hp	42 kW - 57.1 hp
Max torque @	1700 r/min	1700 r/min
SAE J1349 net - DIN ISO 1585	180 Nm	190 Nm
DIN ISO 1585	180 Nm	190 Nm
Cubic capacity	3620 cm ³	3620 cm ³
Bore	94 mm	96 mm
Stroke	112 mm	125 mm

Electrical system

	L20F	L25F
Voltage/Battery capacity	12 V - 88 Ah	12 V - 88 Ah
Alternator rating	1120 - 80 W/A	1120 - 80 W/A
Starter motor output	2.2 kW	2.2 kW

Drivetrain

	L20F	L25F
Oscillation at wheel, max.	226 mm	245 mm
Track	1300 mm	1410 mm
Angle of oscillation	±10°	±10°

Tyre:

	L20F	L25F
Size	12.0-18	12.5-18
Rim	11 x 18	11 x 18

Maximum speed:

	L20F	L25F
1st range forward/reverse	4.5 km/h	5 km/h
2nd range forward/reverse	20 km/h	20 km/h

Brake system

Service brake: reliable dual braking system, acting upon all four wheels.

Steering system

Hydrostatic steering. Central articulating-oscillating joint. Steering pump: gear-type pump.

	L20F	L25F
Steering:		
Angle of articulation	±38°	±38°

Steering system

	L20F	L25F
Steering pump:		
Flow @ engine r/min	25 l/min - 2300 r/min	25 l/min - 2300 r/min
Relief valve pressure	18.5 MPa	18.5 MPa

Cab

Instrumentation: All important information is located in the operator's field of vision.

Hydraulic system

Thermostatically controlled oil circuit with integrated cooling system. Hydraulic control valve: double acting control valve with three spool system.

	L20F	L25F
Control	Control valve three-spool system.	
3rd hydraulic circuit		
Flow @ engine r/min	55 l/min - 2300 r/min	55 l/min - 2300 r/min
Relief valve pressure	20 MPa	23 MPa

Linkage

Parallel linkage with high breakout force and exact parallel liftarm action.

	L20F	L25F
Lift cylinders / Tilt cylinders	1/1	1/1
Lift time (loaded)	6.0 s	6.0 s
Lowering time (empty)	4.0 s	4.0 s
Dump time	2.0 s	2.0 s
Crowd time	1.5 s	1.5 s

Capacities

	L20F	L25F
Engine	10.5 l	10.5 l
Fuel tank	60.0 l	60.0 l
Front axle	4.1 l	4.1 l
Rear axle, incl. drop-box	5.8 l	5.8 l
Hydraulic tank, incl. hydraulic system	60.0 l	60.0 l

Noise levels*

	L20F	L25F
Sound pressure level (LpA) at operator position (Measurement according to ISO 6396)	74 dB(A)	75 dB(A)
Sound power level (LWA) around the machine (Measurement according to 2000/14/EC with applicable appendices and measuring method according to ISO 6395)	99 dB(A)	99 dB(A)

body vibrations

Emission of whole-body vibration values and its uncertainties during operating conditions in different applications, when the machine is used as intended, is according to information in ISO/CEN Technical Report ISO/TR25398.

*NOTE! Uncertainties in given noise values (e.g. uncertainty in production and measuring instruments) are calculated in accordance with ISO 6395:2008 for the sound power level around the machine and ISO 6396:2008 for the sound pressure level at the operator position.

SPECIFICATIONS L20F - L25F

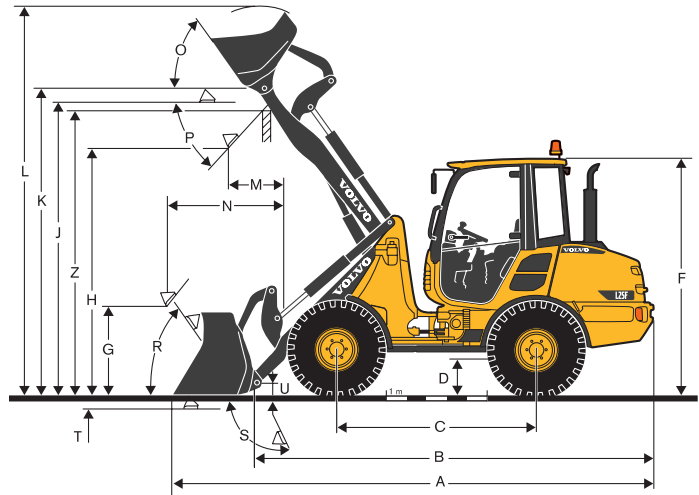
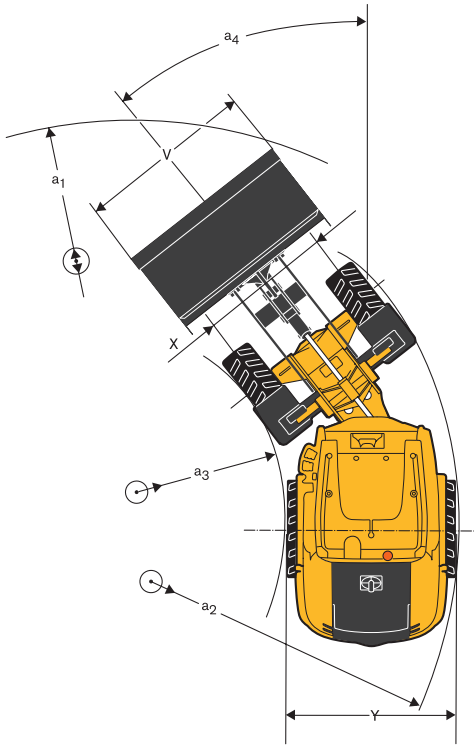





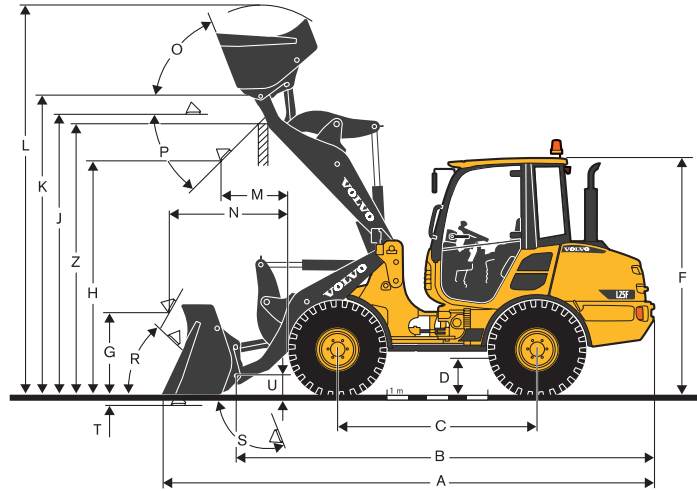
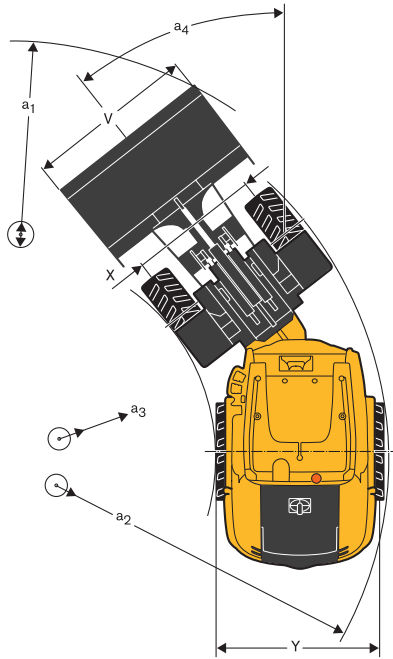

Data according to bucket type		General Purpose		Light material		4 in 1		High Tip			
		L20F	L25F	L20F	L25F	L20F	L25F	L20F	L25F		
L20F with parallel-linkage, 12.0-18 tyres. L25F with parallel linkage, P- attachment bracket and 12.5/80-18 tyres.											
Capacity heaped	m ³	0.7	0.85	0.85	1.0	1.0	1.2	0.65	0.8	1.1	1.1
Material density	kg/m ³	1900	1900	1600	1600	1400	1300	1900	1800	1000	1200
Static tipping load, straight (ISO / DIS)	kg	3250	3800	3200	3750	3150	3700	3000	3400	2500	3100
Static tipping load, full turn 38° (ISO / DIS)	kg	2900	3400	2850	3350	2800	3300	2650	3050	2250	2800
Hydraulic lifting capacity, max.	kN	35.0	41.0	34.0	40.2	33.5	39.5	32.5	37.8	28.0	34.0
Breakout force	kN	35.0	37.0	30.5	32.5	28.0	29.0	36.5	35.7	-	-
A Total length	mm	5035	5085	5135	5185	5195	5285	5005	5110	5510	5500
L Lift height, max.	mm	4060	4100	4140	4195	4190	4290	4070	4085	4890	4890
V Bucket width	mm	1650	1800	1650	1800	1800	1800	1650	1800	1800	1800
a ₁ Clearance circle	mm	8210	8370	8260	8425	8430	8480	8220	8405	8620	8610
T Digging depth	mm	120	105	120	105	120	105	160	145	120	105
H Dump height	mm	2510	2480	2435	2410	2395	2340	2480	2410	3540	3550
M Reach at max. height	mm	660	675	720	745	765	815	575	635	1005	985
N Reach, max.	mm	1475	1475	1535	1535	1580	1580	1390	1390	2140	2140
Operating weight	kg	4300	4300	4330	4330	4340	4340	4460	4460	4670	4670

	L20F with parallel-linkage, 12.0-18 tyres	L25F with parallel linkage, P- attachment bracket and 12.5/80-18 tyres
B	4275 mm	4265 mm
C	2050mm	2050mm
D	300 mm	320 mm
F	2460 mm	2485 mm
G	875 mm	840 mm
J	2980 mm	2990 mm
K	3125 mm	3140 mm
O	56°	56°
P	45°	45°
R	56°	54°
S	65°	65°
U	145 mm	145 mm
X	1300 mm	1410 mm
Y	1625 mm	1735 mm
Z	2885 mm	2895 mm
a ₃	3830 mm	3880 mm
a ₂	2160 mm	2100 mm
a ₄	±38°	±38°

Data with loading fork			
Centre of gravity 500 mm		L20F	L25F
Tipping load, full turn (ISO / DIS)	kg	2290	2670
Payload according to EN 474-3, 60/80%	kg	1350/1800	1600/2100
Payload 80%, transport position, 38° full tur	kg	2200	2500

SPECIFICATIONS L25F



Data according to bucket type		General Purpose		Light material		4 in 1	High-Tip
							
L25F with z-bar linkage and 335/80 R18 tyres							
Capacity heaped	m ³	0.9	1.0	1.2	1.4	0.8	1.2
Material density	kg/m ³	1800	1600	1300	1100	1800	1100
Static tipping load, straight (ISO / DIS)	kg	3615	3570	3475	3425	3300	3100
Static tipping load, full turn 38° (ISO / DIS)	kg	3255	3215	3125	3085	2975	2795
Hydraulic lifting capacity, max.	kN	55.0	54.2	52.8	52.0	51.5	48.0
Breakout force	kN	54.5	47.5	42.0	42.0	51.5	-
A Total length	mm	5265	5365	5470	5470	5305	5620
L Lift height, max.	mm	4135	4175	4265	4265	4050	4950
V Bucket width	mm	1800	1800	1800	2000	1800	1900
a ₁ Clearance circle	mm	8650	8710	8775	8960	8675	8960
T Digging depth	mm	100	100	100	100	105	1005
H Dump height	mm	2500	2420	2345	2345	2440	3610
M Reach at max. height	mm	745	815	885	885	730	955
N Reach, max.	mm	1525	1595	1665	1665	1510	2125
Operating weight	kg	4800	4800	4850	4880	4890	5100

L25F with z-bar linkage and 335/80 R18 tyres	
B	4470 mm
C	2125 mm
D	310 mm
F	2480 mm
G	850 mm
J	2970 mm
K	3170 mm
O	70°
P	45°
R	50°
S	96°
U	200 mm
X	1410 mm
Y	1740 mm
Z	2880 mm
a ₃	3935 mm
a ₂	2155 mm
a ₄	±38

Data with loading fork		
Centre of gravity 500 mm		
Tipping load, full turn (ISO / DIS)	kg	2500
Payload according to EN 474-3, 60/80%	kg	1500/2000
Payload 80%, transport position, 38° full tur	kg	2400

SPECIFICATIONS

STANDARD EQUIPMENT

Engine

Diesel engine, direct fuel injection.
Extra fuel filter.
Cold start aid.
Dry-type air filter.

Electrical system

Alternator 80 A.

Lighting

Main head lights (halogen) upper/dipped/
asymmetrical.
Working light (rear right).
Parking lights.
Rear lights.
Brake lights.
Direction indicators.
Hazard warning lights.
Cab lighting.

Instrumentation & controls

Multi-function lever.
12 Volt accessories socket.
Forward horn.
Hazard warning switch.
Safety start.
Analogue information for:
Fuel level
Operating hours.
Illuminated symbols for:
Differential locks
Battery charging
Indicators (left/right)
Main beam head lamp
Pre-heater (option)
Direction (forward/reverse)

Travel (quick, slow)
Fuel level.
Illuminated symbols with acoustic signal (with
ignition on) for:
Engine temperature
Engine oil pressure
Hydraulic oil temperature
Hydraulic oil filter
Air filter restriction
Parking brake.

Drivetrain

Hydrostatic drive.
Operator-selected 100% differential locks in
both axles.

Cab Exterior

ROPS/FOPS-cab with flexible mountings.
Lockable door.
All-round tinted safety glass.
Windscreen wiper (front/rear).
Windscreen washer (front/rear).
Openable window on the right side.
Door stops.
External rear view mirrors (right/left).

Cab Interior

4-way adjustable operator's seat.
Seat belt.
Sunvisor.
Heater with air-filter and defroster (front/rear)
Cab ventilation.
Storage box in cab.

Hydraulic system

Gear-type pump.
Control valve three-spool system.
3rd hydraulic circuit.

Working Equipment

Hydraulic attachment bracket.

Carriage Body

Fenders (front/rear).
Lockable engine hood.
Vertical exhaust.
Towing device.
Lifting eyes.
Tying down eyes.

International Standards for Machines and Production

Quality: DIN/ISO 9001.
Safety: CE - Criteron.
Machine guide-lines 2006/42/EC.
ROPS ISO 3471.
FOPS ISO 3449.
Operating weight: ISO 7131.
Tipping load / Payload: ISO 14397-1.
EMC (Electromagnetic Compatibility).
89/336/EEC plus supplement
Environment: DIN/ISO 14001.
Sound regulation: 2000/14/EC.

OPTIONAL EQUIPMENT (Standard on certain markets)

Engine equipment

Pre-heater.
Pre cleaner air filter (Turbo II).
Oilbath air filter.

Cab

Handthrottle.
Hand control inch valve.
Airconditioner.
Radio.

Adjustable steering column.
Working lights (2 front/1 rear left).
Air suspension operator's seat.

Working Equipment

Bucket level indicator.

Hydraulic system

Hydraulic couplings for:
3rd hydraulic circuit.
4th hydraulic circuit.
Additional pump.
Single lever with integrated 3rd function

Environment

Biodegradable hydraulic oils.

Safety

Rotating beacon.
Audible reverse alarm.
Anti-theft system.
Protective guards for:
Main head lights
Working lights
Rear lights.

Service and maintenance

Tool kit.



Volvo Construction Equipment is different. Our machines are designed, built and supported in a different way. That difference comes from an engineering heritage of over 175 years. A heritage of thinking first about the people who actually use the machines. About how to help them be safer, more comfortable, more productive. About the environment we all share. The result of that thinking is a growing range of machines and a global support network dedicated to helping you do more. People around the world are proud to use Volvo. And we're proud of what makes Volvo different - **More care. Built in.**



Not all products are available in all markets. Under our policy of continuous improvement, we reserve the right to change specifications and design without prior notice. The illustrations do not necessarily show the standard version of the machine.

VOLVO

Volvo Construction Equipment
www.volvoce.com

PUB 21A1006322
2010.03
Volvo, Global Marketing

English (Global)
CWL