

Versatile top performer for professional applications.

# Cold Milling Machine W 210 / W 210i



# Outstanding features of the W 210/W 210i cold milling machine

02  
03

4 |

## MACHINE FRAME

- > **Perfect visibility**  
Slender machine frame design at the front including dual wasp waist for a perfect view of the milling edge.
- > **Ease of transport**  
Ease of transport due to low machine weight and variable supplementary weights of up to 1,700 kg.

3 |

## ENGINE STATION

- > **Dual Engine Concept**  
Dual engine concept for extra low diesel consumption and high milling performance.
- > **Three different milling drum speed options**  
Three selectable cutting speeds for optimum milling performance in a broad range of applications.
- > **Load-controlled fan speed**  
Fan speed governed by engine temperature for low energy consumption and low noise emission levels.

2 |

## ELECTRICAL SYSTEM

- > **Emergency operation**  
Electrohydraulic power pack to raise machine in emergency mode.
- > **Camera system**  
Robust camera system including up to six cameras and up to two screens.
- > **Job data**  
Precise recording of job data including "truck full" message.

1 |

## LEVELLING

- > **Large choice of sensors**  
LEVEL PRO automatic levelling system as standard equipment, offering a large choice of sensors and highly precise control of the milling depth.
- > **Milling depth indicator**  
Milling depth indicator on the LEVEL PRO screen (showing difference between scraper blade and side plate positions).
- > **Scanning in front of the milling drum**  
Scanning in front of the milling drum via hydraulic cylinders with integrated measuring system - suitable for use also with the Multiplex system.
- > **Automatic system to initiate the milling process**  
Automatic system to initiate the milling process with load-controlled lowering speed.



5 |

## OPERATOR'S PLATFORM

### > Multifunctional joystick

Multifunctional joystick with driving, steering, selecting operating mode, raising machine and switching off conveyor functions.

### > Ergonomics

Ergonomically designed, backlit controls for non-tiring, productive working.

### > Hydraulically moving and swivelling operator's cabin

Optionally available Operator Comfort System (OCS) for an ideal working environment.

### > Protective canopy

Fixed protective canopy with telescoping side panels for maximum protection from inclement weather.

### > Parallel alignment of machine

Automatic parallel alignment of the machine both during the milling operation and in transport mode.

6 |

## CONVEYOR SYSTEM

### > Large slewing angles

Conveyor slewing angles of 60° to both sides to optimize the loading process.

### > Tremendous conveying capacity

High conveyor loading capacity and drive power for highly efficient material loading.

### > Vacuum Cutting System

Vacuum Cutting System for improved visibility.

### > Folding conveyor with locking mechanism

Folding conveyor with intelligent mechanical locking mechanism for easy transport.



7 |

## MILLING DRUM UNIT

### > Locking of scraper blade

Automatic mechanical locking of scraper blade to ensure ease of operation.

### > FCS LIGHT

FCS Light for the quick replacement of milling drums in FB2000 and FB2200 milling drum units.

### > HT22 quick-change toolholder system

Extra efficient, tried-and-tested HT22 quick-change toolholder system as standard equipment.

### > Right-hand side plate lift of 450 mm

Right-hand side plate can be raised by up to 450 mm to allow flush-to-kerb milling at the full milling depth.

### > Load-controlled water spray system

Water spray system with automatic adjustment to the milling performance for optimum tool cooling.

### > Milling drum turning device

Drum turning device to enable cutting tool replacement with the diesel engine switched off.

8 |

## TRACTION DRIVE

### > Hydraulic pre-tensioning of track chains

Hydraulically pre-tensioned track chains for optimized operation.

### > Traction control

Intelligent electronic traction control system for the track units.

### > Track speed adjustment

Electronic adjustment of the track speed during cornering to ensure maximum traction and low wear and tear.

### > Four-fold full-floating axle

Four-fold full-floating axle for optimum machine stability.



# A milling pro offering the full range of applications.



THE WIRTGEN W 210 / W 210i. EPITOME OF HIGH PERFORMANCE, QUALITY AND EXPERTISE. THE LARGE MILLING MACHINE IS PACKED WITH STATE-OF-THE-ART TECHNOLOGIES, SUCH AS THE INNOVATIVE DUAL ENGINE CONCEPT. THE W 210 / W 210i - PRIME CHOICE FOR A WIDE VARIETY OF ROAD REHABILITATION MEASURES. FLEXIBLE APPLICATION. COMPELLING PERFORMANCE.



*The innovative W 210/W 210i is a role model in performance and economy.*

## By the pros for the pros

### MAXIMUM FLEXIBILITY

State-of-the-art construction machines need to cope with ever higher demands. Contractors expect high performance levels and economic efficiency without wanting to compromise on maximum flexibility. The W 210/W 210i perfectly meets these requirements: milling performance and versatility in application are tremendous, and the intelligent WIDRIVE machine management system cuts operating costs. Additional highlights of the W 210/W 210i include the PTS parallel alignment system, ISC track control, FCS Light

quick-change system for milling drums, three adjustable milling drum speeds and, unprecedented in the cold milling industry, the innovative Dual Engine Concept. The drive design of the W 210/W 210i featuring two combustion engines offers maximum economic efficiency regardless of the working situation.



1 | The W 210/  
W 210i clears  
construction sites  
easily thanks to its  
powerful conveyor  
system.

2 | Ergonomically  
optimized design  
and ease of opera-  
tion prevent fatigue  
during work.



# High productivity tailored to accurate fit

## A BROAD RANGE OF APPLICATIONS

The low-weight W 210/W 210i is considered a role model in performance capacity – and an ideal candidate in a broad range of applications. While its high engine power caters to all needs on large milling sites, its high milling performance, outstanding manoeu-

vrability and compact design ensure rapid and professional completion also on small to medium-sized construction projects. The large milling machine rehabilitates all kinds of large areas with maximum efficiency – from the milling of surface courses to the complete removal of individual motorway lanes at full depth.

The W 210/W 210i lets performance speak for itself even when space is limited, for example, in the area of a road junction or on urban milling sites. Regardless of whether a milling drum assembly with a working width of 1.5 m, 2.0 m or 2.2 m is used, the unrivalled milling depth enables the removal of complete pavements in a single pass.







# Cut cost – boost revenue

## THREE DIFFERENT MILLING DRUM SPEED OPTIONS

Our design engineers know how to fully utilize the potential a cold milling machine has to offer. They have succeeded in presenting a true innovation that enables ideal milling outputs to be achieved not only under frequently varying and highly demanding conditions but also in a wide variety of different applications.

A selector switch on the operator's platform serves to set three different speed levels of the engine and/or the milling drum. As a rule, the W 210/W 210i operates at the medium milling drum speed, whereas the high speed is selected for large-scale fine milling jobs at high advance speeds. The low speed is chosen to achieve maximum milling performance levels at reduced fuel consumption rates per cubic metre of milled material and low cutting tool wear and tear. To put it in a nutshell: minimum cost and maximum productivity – made by WIRTGEN.

## DIFFERENT MILLING DRUM SPEEDS FOR SPECIFIC MILLING JOBS

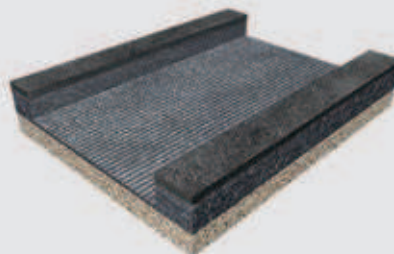

**Low speed:**  
complete removal at full depth

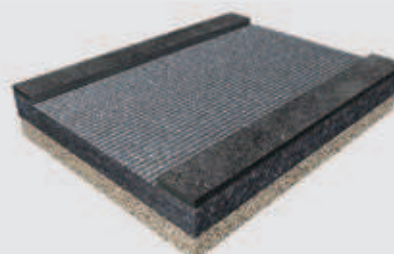

**Medium speed:**  
milling of surface courses,  
thin road pavements etc.

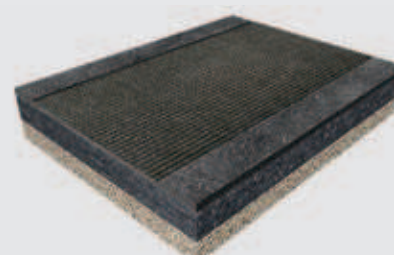

**High speed:** fine milling





**More operator comfort.**

**More ergonomics.**

**More productivity.**

UNRIVALLED COMFORT AND ERGONOMICS ON THE OPERATOR'S PLATFORM OF THE W 210 / W 210i. YOU ARE IN COMMAND AT THE CONTROL PANEL OF THE LARGE MILLING MACHINE WHILE OTHERS WORK IN THE BACKGROUND: INNOVATIVE CONTROL TECHNOLOGIES. THE INTELLIGENT VISIBILITY CONCEPT DRAWS YOUR ATTENTION TO THE IMPORTANT WORK PROCESSES. EVERYTHING FOCUSES ON A SINGLE GOAL: EVEN HIGHER PERFORMANCE.



## Gaining control quickly

### A SMALL NUMBER OF BUTTONS AND SWITCHES

Climb the operator's platform, and here goes! It takes no more than a short training period to be able to operate the W 210/W 210i just as intuitively as a milling pro. True to the saying that "less is more", the operator needs to familiarize himself with a small number of controls only as the WIDRIVE machine management system takes care of numerous functions fully automatically. The clearly arranged controls are labelled in a language-neutral fashion, enable perfect handling and help to prevent fatigue during work. In addition, the clearly

structured colour control screen keeps the operator informed of important machine and operation parameters.

At the customer's request, the W 210/W 210i can be equipped with the Operator Comfort System (OCS) in lieu of the standard operator's platform. The hydraulically moving and swivelling cabin can be adjusted to the optimum position for the operator to have full visibility at all times. Camera transmission, precise joystick control and a powerful automatic climate control system provide a perfect working environment regardless of weather conditions.



1-2 | The workplace has been equipped with two identical control panels left and right.

3 | Optional OCS: the sound-insulated cabin offers good all-round visibility as well as weather protection and air-conditioned interior temperatures.

# Giving operators the full picture - at all times

## JOB PARAMETERS AND CAMERA IMAGES AT A GLANCE

The multifunctional control screen provides clear information on operational parameters and maintenance details. User-friendly diagnostic tools with clear illustrations ensure the transparency of diagnostic procedures. Continuous logging of events during the milling process is yet another useful feature. In addition, the control system displays information such as the weight and volume of the material milled, size of the milled area or number of trucks loaded automatically after manual entry of the material density and milling width. These job data enable easy logging of daily production rates.

The control screen can be switched to camera mode to monitor important work processes. Two or six cameras with high-resolution colour screens can be installed in accordance with customer specifications. When using six cameras, an additional camera screen is installed to allow two camera views to be displayed simultaneously.

The WIRTGEN WITOS FleetView telematics system supports fleet management, machine position and status monitoring, as well as maintenance and diagnostic procedures. In short: it is yet another key driver for improved efficiency in day-to-day operation.

### OVERVIEW OF CAMERAS:

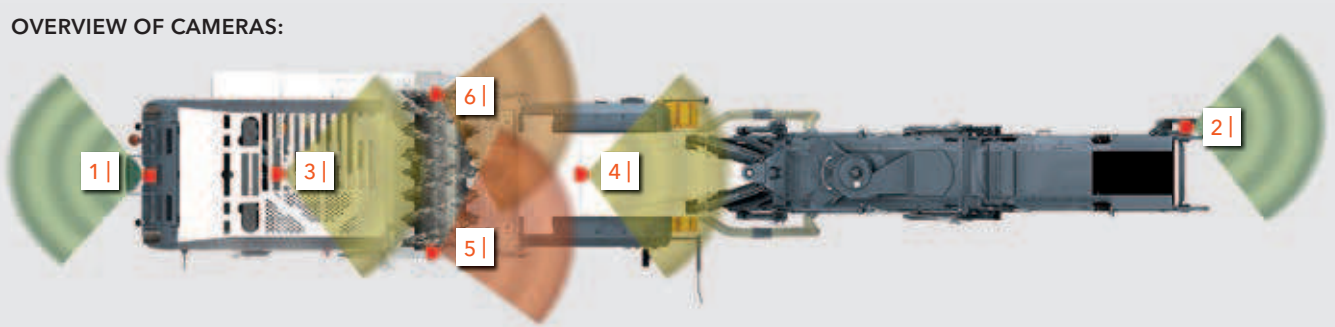

1 | Camera at the rear



2 | Camera at end of conveyor



3 | Camera at scraper



4 | Camera front, centre



5 | Camera front, right



6 | Camera front, left



Operating parameters:



Job data:



Diagnostics of milling drum unit:

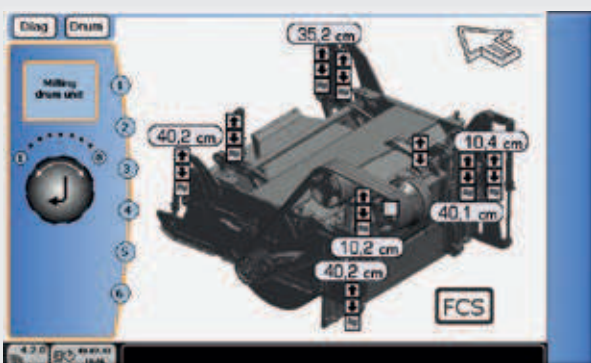

Diagnostics of height adjustment:

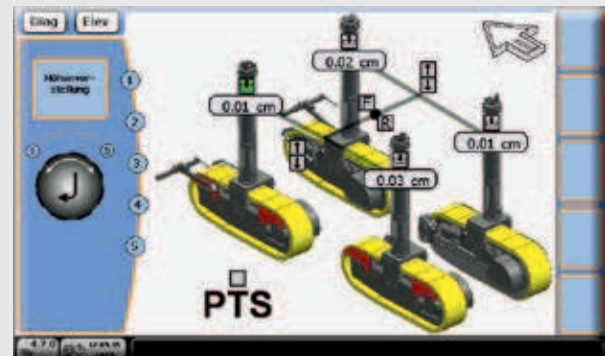

# Fully focused on the milling job

*Working in upright or seated position, movable control panels, individually adjustable comfort seats.*



## PERFECT VISIBILITY IN A COMFORTABLE WORKING POSTURE

Milling machine operators want to operate their machines at maximum performance levels, yet come down from the operator's platform at the end of the working day feeling well and fit. The W 210/W 210i combines both requirements as it offers a truly perfect ergonomic design. One of the main features is the slender wasp waist of the W 210/W 210i which enables an unobstructed view of the milling edge, track units and protective side plates. It is complemented by individually adjustable dual control panels and height-

*Wasp waist design for perfect visibility from the anti-vibration mounted operator's platform; the railing can be moved to the outside.*

adjustable driver's seats. A swivel arm enables the seats to be positioned between the control panel and guard rail. All of these features combine into a perfect panorama design, and milling in both upright and seated position can proceed with the greatest ease.

A protective canopy mounted in a fixed position relative to the operator's platform fully protects the entire operator's platform from the elements. The canopy can be extended on the left and right as needed by means of additional, independently telescoping roof elements.





# LEVEL PRO - state-of-the-art levelling technology

## PRECISE MILLING RESULTS

WIRTGEN has developed an ultra-precise proprietary levelling system that includes a software programmed specifically for cold milling machines - LEVEL PRO. The overall system comprises the clearly structured LEVEL PRO panel, a controller and multiple sensors. A wide variety of different sensors, such as milling depth, cross slope or ultrasonic sensors, can be integrated into the automatic levelling system. The graphics-enabled LEVEL PRO panel provides a clear readout of key parameters. For example, the set and actual values of two active sensor signals and one passive sensor are continuously displayed on the screens as work progresses. An additional milling depth indicator on the screen - showing the difference between scraper blade and side plate positions - enables convenient monitoring of the actual milling depth. In addition, the memory feature is extremely useful to pre-programme, store and retrieve set values.

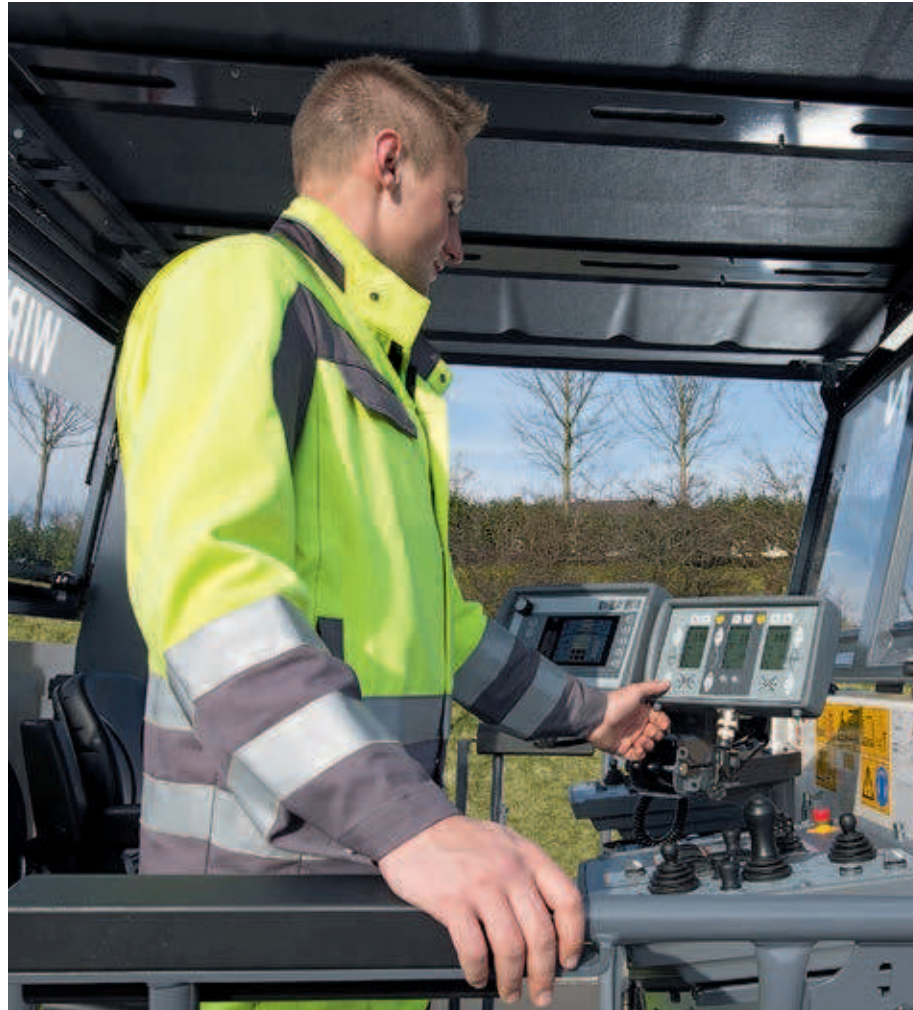

### LEVEL PRO SCREEN

Automatic ON/OFF

Settings

Switchover button

Set value

Set value UP/DOWN

Actual value

Calibration

Controller output

Cylinder UP/DOWN

Memory 1

Memory 2







**Double power –  
high efficiency.**

**POWER. EFFICIENCY. INTELLIGENCE. THESE ATTRIBUTES COMBINE INTO THE INNOVATIVE DUAL ENGINE CONCEPT IMPLEMENTED IN THE WIRTGEN W 210 / W 210i LARGE MILLING MACHINE. INTELLIGENT PERFORMANCE CONTROL. POWERFUL TORQUE. IMPRESSIVE STRENGTH. MAXIMUM EFFICIENCY OF YOUR WIRTGEN MACHINE.**

# State-of-the-art Dual Engine Concept

20  
21

## W 210 (US TIER 3) - HIGH-PERFORMANCE ENGINE TECHNOLOGY

The engine technology used in the W 210 cold milling machine complies with the emission standards of EC Stage 3a/US Tier 3 or lower. The W 210 is equipped with two independently operating, powerful and economical ECO engines, the second engine being switched on or off as needed in the working situation.

The fully electronic WIDRIVE machine management system enables both of the W 210's engines to always work in the ideal performance and torque ranges, at extremely low fuel consumption rates and low operating costs.

## W 210i (US TIER 4 FINAL) - OPTIMIZED ENVIRONMENTAL PROTECTION

The W 210i features state-of-the-art engine technology for extremely low environmental emission levels, complying with the stringent specifications of exhaust emission standards EC Stage 4/US Tier 4f.

To ensure effective exhaust gas purification, both engines of the W 210i are equipped with two-way and SCR catalytic converters. The WIDRIVE machine management system guarantees consistently high performance levels even when working at full load. Operating costs of the W 210i are reduced even further thanks to intelligent diesel engine control.

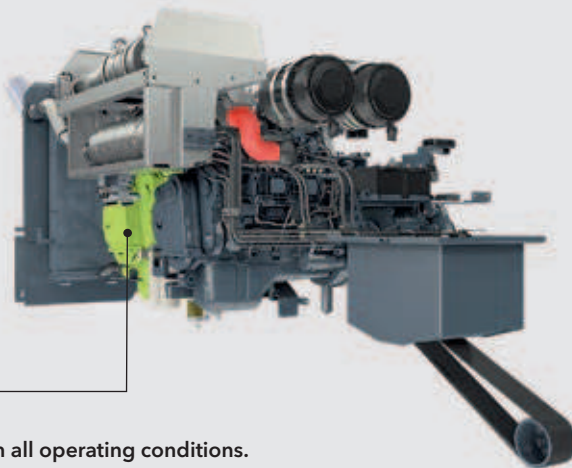

Engine 1

Engine 1 is running in all operating conditions.

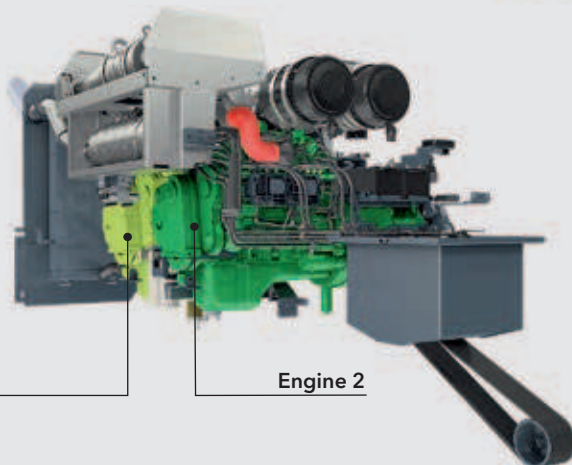

Engine 1

Engine 2

Engine 2 is switched on or off depending on requirements.

## IT TAKES TWO TO BOOST ECONOMIC EFFICIENCY

WIRTGEN is the first cold milling machine manufacturer worldwide to offer uncompromising performance characteristics and maximum efficiency by connecting two diesel engines by means of a multiple V-belt. Engine 1 only is in operation in those conditions where the performance level required to achieve the specified results is low. While engine 1 drives all functional groups, engine 2 is switched on automatically or at the push of a button for full milling power.

This offers significant advantages: switching off engine 2 results in reduced noise emissions, the operator is exposed to fewer vibrations, and lower exhaust gas emission levels cause less harm to the environment. Needless to say that diesel fuel consumption rates are also lowered significantly.

## W 210 ENGINE CHARACTERISTICS:

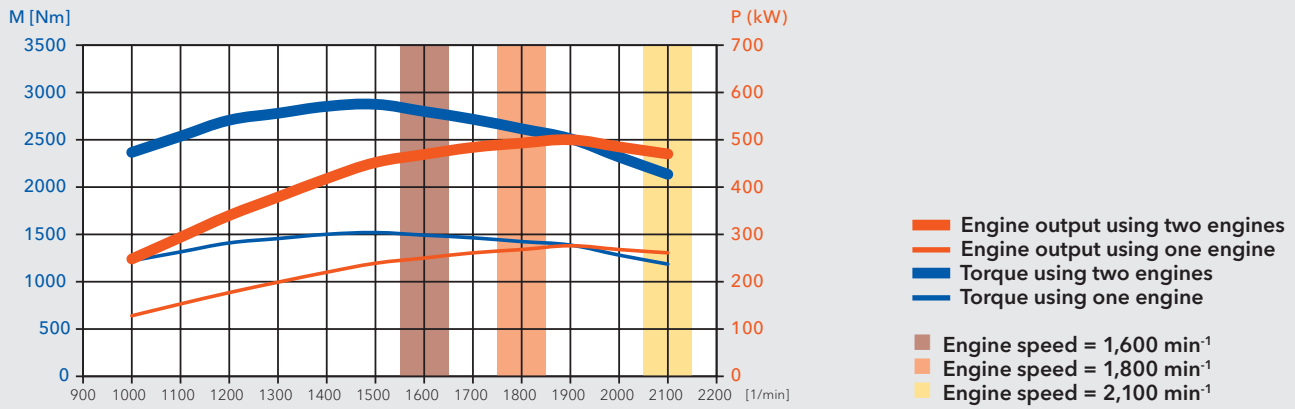

## W 210i ENGINE CHARACTERISTICS:

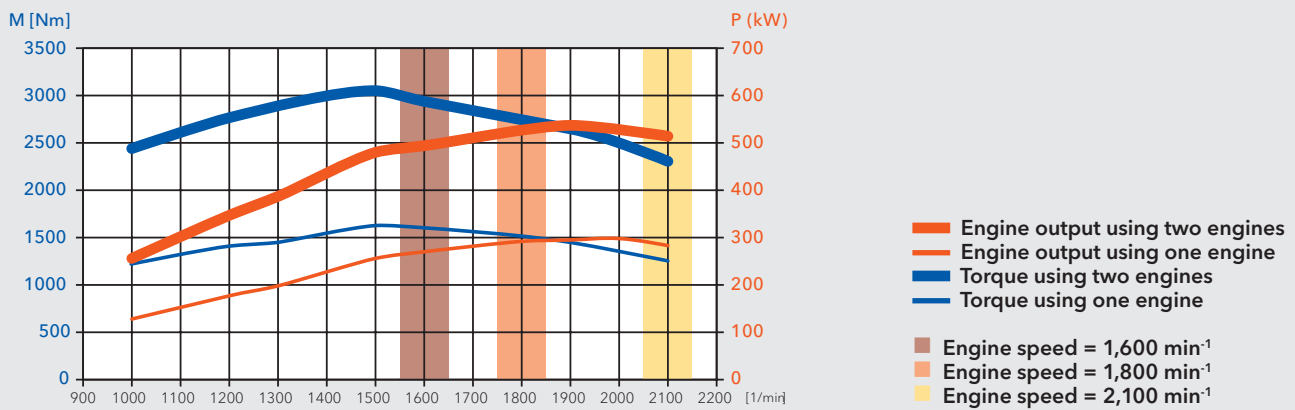

# Maximum efficiency

## HIGHLY EFFICIENT MECHANICAL MILLING DRUM DRIVE

The power of the W 210/W 210i large milling machine is provided by a mechanical milling drum drive offering an exceptionally high degree of efficiency. An automatic belt tensioner ensures uniform power transmission, while the power belts absorb peak loads and reduce the load exerted on the various components of the drive system.

Additional marks in favour of the tried-and-tested drive design are reduced fuel consumption rates, high wear resistance and ease of maintenance.







Precise steering.

Always on track.

THE CHALLENGES POSED BY A MILLING SITE: PERMANENTLY INSTALLED ROAD FIXTURES, HIGH MILLING EDGES. DIFFICULT GROUND CONDITIONS, RESTRICTED SPACE. MASTERED QUICKLY AND WITH SUPERIOR EASE USING TRIED-AND-TESTED-TECHNOLOGIES. SUCH AS PTS - AUTOMATIC PARALLEL ALIGNMENT OF THE MACHINE - OR ISC - ELECTRONIC TRACK SPEED CONTROL.



*All four track units feature large steering angles permitting surprisingly small turning circles.*

## ISC – gaining ground quickly the intelligent way

### FULL TRACTION AND OUTSTANDING MANOEUVRABILITY

Work on milling sites is often made difficult by rough and uneven terrain. The magic word is – traction. Optimum, uniform traction is ensured by the intelligent ISC (Intelligent Speed Control) track control system: electronic traction control minimizes the slip of individual

track units even in difficult milling situations. In addition, ISC keeps the machine's advance rate within the optimum engine load range and electronically aligns the cornering speeds of the inner and outer track units, thus minimizing track pad wear.

*Crab steering enables the machine to precisely approach the milling edge.*

The steering angles of the front and rear axles are coordinated, and the rear axle is tracked automatically for perfect milling results. But the W 210/W 210i has even more to offer: small turning radii, selectable steering modes and height-adjustable track units offer excellent driving properties.





# PTS - always parallel to the road surface

## PARALLEL MACHINE ALIGNMENT

It takes quite a lot to throw the W 210/W 210i off balance. Its stability is based on PTS: the intelligent automatic system aligns the machine parallel to the road surface in a dynamic process without requiring manual intervention by the machine operator. The front and rear track systems are lowered evenly and in parallel to each other. In addition, the four-fold full-floating axle that forms part of the PTS system quickly and reliably compensates for any irregularities transverse to the direction of travel.

Surface irregularities are levelled out by the machine's four hydraulically interlinked lifting columns. The effective stability control of the W 210/W 210i pays for itself - it ensures precise maintenance of the milling depth and speeds up the entire work process without the operator having to intervene manually.

*The cold milling machine aligns parallel to the pavement surface automatically.*

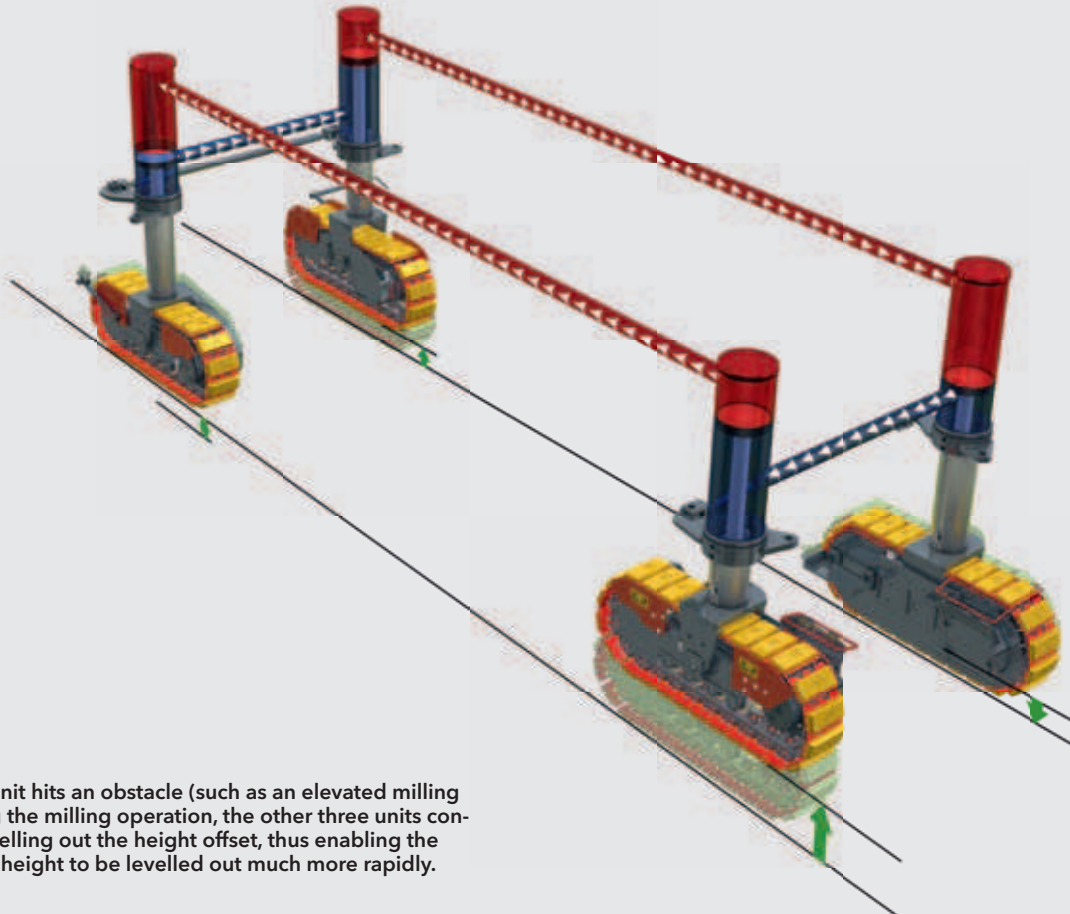

If one track unit hits an obstacle (such as an elevated milling edge) during the milling operation, the other three units contribute to levelling out the height offset, thus enabling the difference in height to be levelled out much more rapidly.

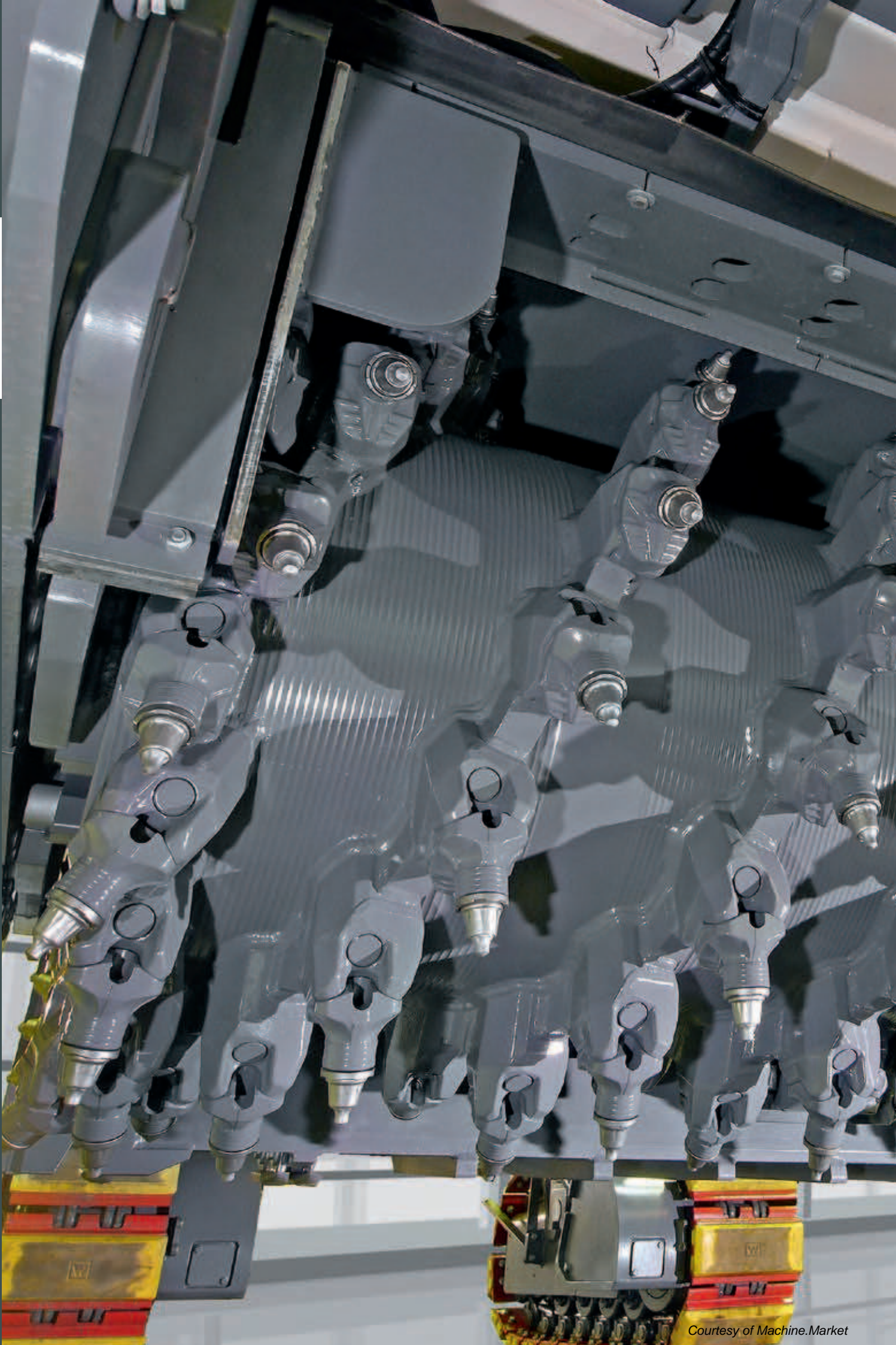



# Our expertise in milling for your success.

**EXTENDED LIFESPAN GUARANTEED. THANKS TO THE INNOVATIVE, HEAVY-DUTY DESIGN OF THE MILLING DRUM. MANUFACTURED FROM EXTREMELY WEAR-RESISTANT MATERIALS. BASED ON SPECIFIC EXPERTISE GAINED IN SEVERAL DECADES OF EXPERIENCE IN CUTTING TECHNOLOGY. COST-OPTIMIZED. SO THAT WE CANNOT ONLY MEET BUT EXCEED YOUR REQUIREMENTS IN EFFICIENCY AND PRODUCTIVITY.**

# HT22 for increased profitability on the job site

## LONG SERVICE LIFE IN EVEN THE TOUGHEST JOBS

*The electrohydraulically operated tool extractor improves the machine's overall productivity.*

The heavy-duty HT22 quick-change toolholder system minimizes breaks in operation as it has been designed for tough operating conditions.

This is ensured by the use of exceptionally wear-resistant materials, perfect tool rotation and easy tool replacement - to name just a few of its many advantages. Cutting tool replacement can be facilitated further by means of a hydraulic drum turning device and an additional seat mounted between the rear track units.

The cutting tools are replaced using either standard manual or pneumatic extractors or - to optimize the process - an electrohydraulic tool extractor which extracts the tools effortlessly with the engine switched off.



## HT22 QUICK-CHANGE TOOLHOLDER SYSTEM IN DETAIL

- 1 | Extremely large maximum wear distance
- 2 | Wear markers at 5 mm intervals
- 3 | High wear volume
- 4 | Optimized shank angle geometry for high component strength
- 5 | Large shank cross-section for significantly higher fracture strength
- 6 | Protective plug prevents soiling of bolt head
- 7 | Heavy-duty retaining bolt
- 8 | Seal between upper part and bottom part to allow simple insertion/removal of upper part
- 9 | Upper part covers bottom part completely for full protection of bottom part
- 10 | Extra large contact surface between upper part and bottom part for extended bottom part life
- 11 | Optimized welded connection offering increased strength and simultaneous flexibility for optimum tool rotation

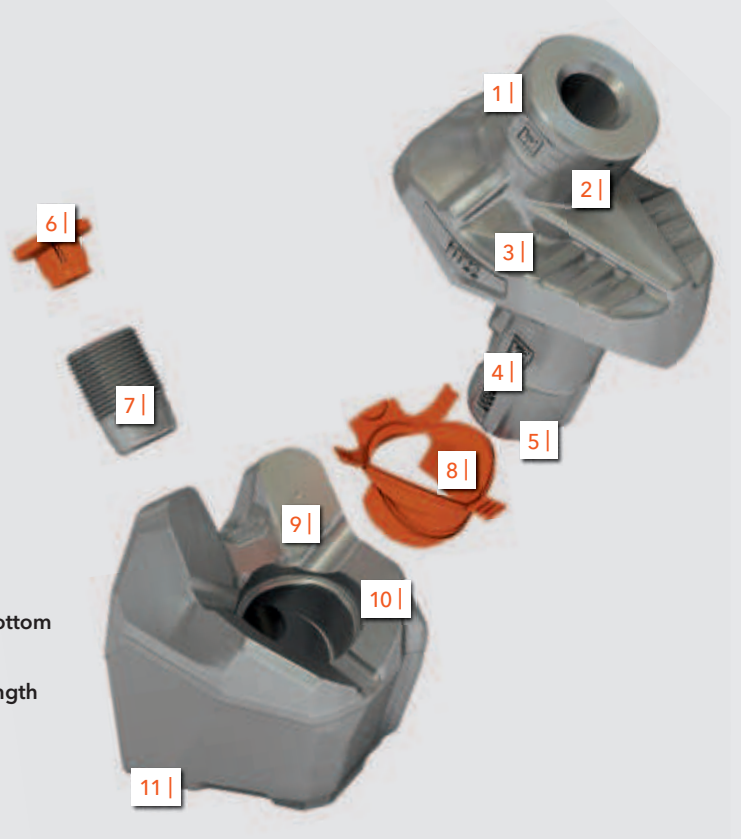

Dimensions in mm:

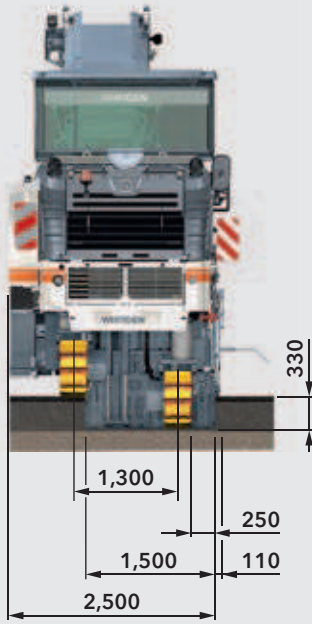

W 210/W 210i with 1.5-m drum assembly



Standard milling drum  
Milling width: 1,500 mm  
Milling depth: 0-330 mm  
Tool spacing: 15 mm

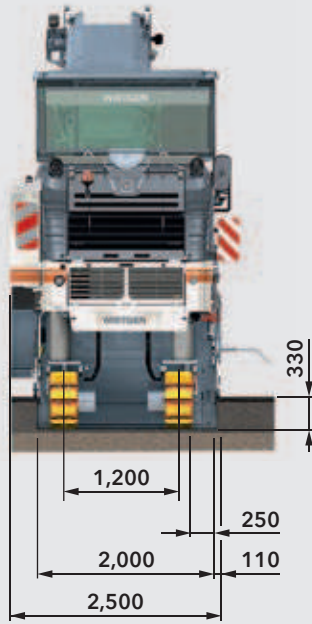

W 210/W 210i with 2.0-m drum assembly



Standard milling drum  
Milling width: 2,000 mm  
Milling depth: 0-330 mm  
Tool spacing: 15 mm

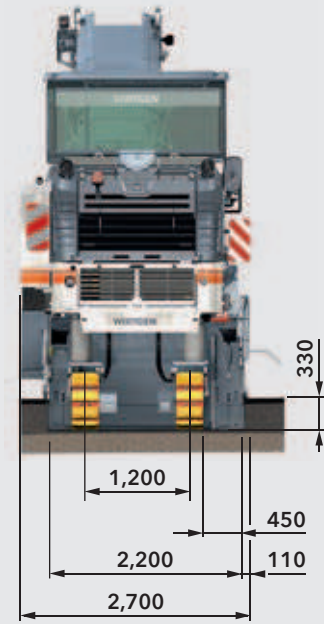

W 210/W 210i with 2.2-m drum assembly



Standard milling drum  
Milling width: 2,200 mm  
Milling depth: 0-330 mm  
Tool spacing: 15 mm

# Milling drum assemblies 1.5 m, 2.0 m and 2.2 m wide

## DIFFERENT WORKING WIDTHS

In the standard package, the W 210/W 210i comes with a 2.0 m wide milling drum unit; 1.5 m or 2.2 m wide drum units are available as optional equipment features. At a working width of 2.2 m, a 4.35 m wide road surface (first lane and median strip) is milled off in only two passes, whereas three milling passes are required at a working width of 2.0 m.

The 2.0-m and 2.2-m milling drum assemblies are suitable for use with the FCS Light system so that milling drums of equal width can be exchanged without difficulty.



# FCS Light increases flexibility and machine utilization

## FCS LIGHT FOR MILLING WIDTHS OF 2.0 M AND 2.2 M

High levels of utilization are a key factor in the profitable operation of large cold milling machines. The W 210/W 210i fully meets this requirement when equipped with the FCS Light Flexible Cutter System: milling drums of equal working widths - but with different tool spacings - can be exchanged with only little effort. The system's real-life design and supporting tools, such as a special mounting carriage, allow the drums to be exchanged in an extremely short period of time.

As a result, a single cold milling machine can remove wheel ruts on a country road, prepare a surface for the application of a thin pavement layer by means of fine milling, or remove the coating from an asphalt or concrete pavement when equipped with a micro-fine milling drum. FCS Light is available for working widths of 2 m and 2.2 m.

Standard milling drums are ideally suited to the removal of one or more pavement layers, ensuring a good interlock between the milled surface and the new pavement.

Fine milling drums create finely textured surfaces ideally suited as a base for the application of thin pavement layers.

Micro-fine milling drums are used to roughen road pavements and to improve their evenness and skid resistance.

## DIFFERENT TYPES OF MILLING DRUMS

The ECO cutters equipped with a reduced number of point-attack tools ensure the highest possible area performance.



**ECO cutter**  
Milling width: 2,000 mm  
Milling depth: 0-330 mm  
Tool spacing: 25 mm



**ECO cutter**  
Milling width: 2,200 mm  
Milling depth: 0-330 mm  
Tool spacing: 25 mm



**Standard milling drum**  
Milling width: 2,000 mm  
Milling depth: 0-330 mm  
Tool spacing: 15 mm



**Standard milling drum**  
Milling width: 2,200 mm  
Milling depth: 0-330 mm  
Tool spacing: 15 mm



**Fine milling drum**  
Milling width: 2,000 mm  
Milling depth: 0-100 mm  
Tool spacing: 8 mm



**Fine milling drum**  
Milling width: 2,200 mm  
Milling depth: 0-100 mm  
Tool spacing: 8 mm



**Micro-fine milling drum**  
Milling width: 2,000 mm  
Milling depth: 0-30 mm  
Tool spacing: 6 x 2 mm



**Micro-fine milling drum**  
Milling width: 2,200 mm  
Milling depth: 0-30 mm  
Tool spacing: 6 x 2 mm



# Automatic lowering of the drum into working position



*The cold milling machine retains its parallel alignment.*

## START MILLING WITHOUT LOSING TIME

The innovative automatic system used to initiate the milling process allows the machine to mill at the maximum depth of 330 mm right from the very first metre.

When the automatic levelling system is engaged, the lifting columns and rotating milling drum are lowered automatically at maximum speed. Once the side plates reach the ground, the lifting columns continue lowering in slow mode; the lowering rate is adjusted further in the milled cut if required.

The milling machine retains its parallel alignment - no time is wasted on complex manual lowering operations front and rear.

## FRONT AND REAR TRACK SYSTEMS ARE LOWERED QUICKLY TO THE SET MILLING DEPTH



1 | Cold milling machine in transport position

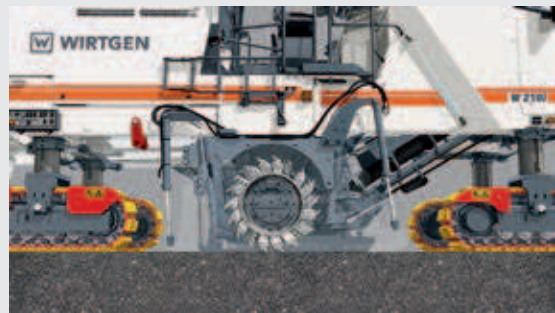

2 | Cold milling machine is lowered quickly while retaining its parallel alignment



3 | Cold milling machine is lowered slowly while retaining its parallel alignment



4 | Cold milling machine mills at full working depth right from the first metre





# Flexible milling drum assembly

## INTELLIGENT DESIGN

The milling drum assembly of the W 210/ W 210i offers an extremely high degree of flexibility. The hydraulically height-adjustable protective side plates left and right permit precise milling along road fixtures. The right-hand side plate can be raised by 450 mm. Milling flush to kerb is thus possible also at large working depths.

The scraper blade is raised and lowered hydraulically in order to load all or part of the milled material, or to leave it behind in the milled cut. To prevent collisions during manoeuvring, the gradation control beam, scraper blade and side plates are raised automatically together with the lifting columns when in transport mode.

A high-capacity water spray bar ensures optimum tool cooling thanks to load-controlled water pressure and continuously variable amounts of water added. This feature increases tool durability and reduces the generation of dust.

*The right-hand side plate can be raised by a total of 450 mm.*

Dimensions in mm:







# Material loading -

# here's how the pros do it.

THE PERFECTION OF A COLD MILLING MACHINE LIES IN THE INTERACTION OF ITS STRENGTHS. THE STATE-OF-THE-ART, HIGH-CAPACITY CONVEYOR SYSTEM OF THE WIRTGEN W 210/W 210i IS ONE OF THEM. THE TOP PERFORMER CLEARS AWAY MANY TONNES OF MILLED MATERIAL. POWERFUL AND EFFICIENT. FLEXIBLE AND RELIABLE. PERFECTION FOR THE MILLING PROS.

# Removing tonnes of milled material quickly

1 | Slewing angles of 60° to both sides ensure flexibility in material loading.

2 | For quiet operation at night: clearly visible "Stop" and "Go" instructions given to the truck driver.





## HIGH-PERFORMANCE CONVEYOR

Rapid removal of the milled material from site significantly contributes to the smooth completion of large milling projects. Accordingly, as many trucks as possible need to be loaded within the shortest possible time. Our W 210/W 210i large milling machine has no problem at all with mastering this job, as its conveyor system easily copes with clearing many tonnes of milled material due to extremely high conveyor capacity and drive power.

The conveyor system features continuously adjustable belt speed control to achieve optimum distribution of the milled material on the trucks by setting a variable discharge range. In addition, large slewing angles enable even challenging loading procedures to be effected smoothly in narrow bends or in those sections where space is limited.

*Continuously adjustable belt speed and discharge range.*

-  High belt speed
-  Low belt speed



# Vacuum Cutting System offers a pleasant working environment

## FREE VIEW OF THE MILLING EDGE

When developing the W 210/W 210i, particular attention was paid to the health and well-being of the operating crew. For this reason, the cold milling machine can be fitted with the Vacuum Cutting System to extract fine material particles. Its principle is simple: by creating a negative pressure in the drum housing, the mix of air and water vapour is evacuated and then fed back into the flow of milled material transported on the conveyor via a hose system.

It goes without saying that better air quality and visibility in the working environment of the machine operator and ground crew members significantly improve the working conditions and boost staff performance. Reduced soiling of components, such as the engine or air filter, results in savings in the replacement of spare parts.



*The centrifugal fan can be adjusted in speed.*

*VCS ensures a perfect view of the milling edge regardless of the time of day or night.*

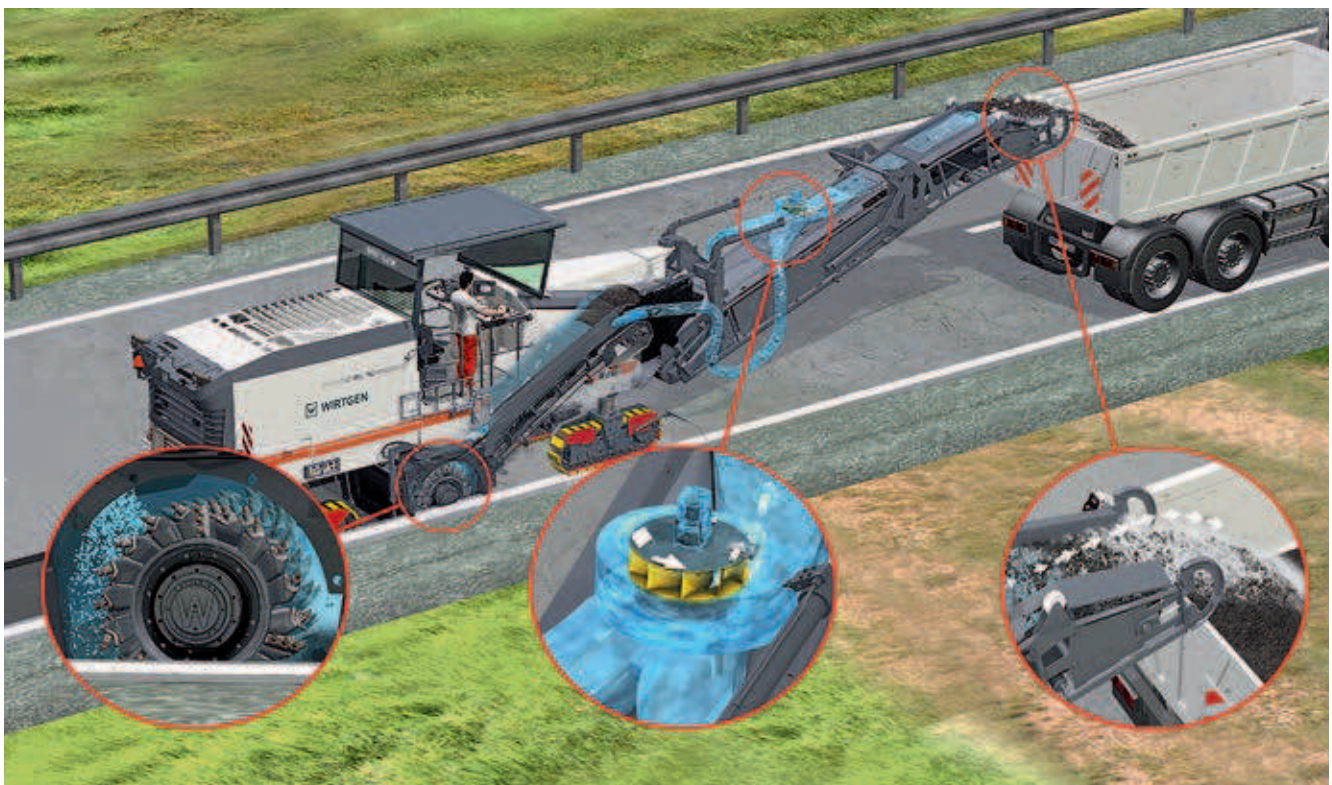





**Operational  
availability guaranteed.**

WITH THE W 210 /W 210i, YOU ACQUIRE CUTTING-EDGE TECHNOLOGY. A PREREQUISITE FOR PERMANENT OPERATIONAL AVAILABILITY AND HIGH DAILY PRODUCTION RATES. EASE OF SERVICING, EXTENDED MAINTENANCE INTERVALS, INTELLIGENT LIGHTING SYSTEM. NOTHING IS MORE IMPORTANT TO US THAN ENSURING THE OPERATIONAL AVAILABILITY OF YOUR COLD MILLING MACHINE.



# Intelligent maintenance pays off

## FOR MAXIMUM MACHINE AVAILABILITY

Enabling the machine operator to complete maintenance procedures quickly and reliably is a major criterion for ensuring maximum availability of a machine on the construction site. The engine compartment of the W 210/W 210i opens at the push of a button, and the service panels can be slewed wide open. The few points of maintenance are arranged in a clear pattern and offer easy access from the ground or from the operator's plat-

form. Maintenance procedures on the filters, engine or hydraulic system are completed in a few simple steps.

As a result, the W 210/W 210i is always in top shape and prepared to deliver top milling results. And the operator is happy, too.





1 | Ample space: all filters are within easy reach and can be replaced effortlessly.

2 | On-board maintenance diagnostics and parameter settings via the control panel.



*A comprehensive lighting system offers excellent visibility during night operations.*

# Ready for operation - whatever the time of day

## GOOD LIGHTING FOR PERFECT OPERATION AT NIGHT

Road construction projects are often carried out under tremendous time pressure, making it impossible for milling contractors to care about adverse weather conditions, darkness

*Backlit control panels permit operation in darkness.*

or even night time. This is where the comprehensive lighting equipment of our versatile large milling machine comes into play. Numerous adjustable working lights are attached quickly and easily to fully illuminate the main working areas of the W 210/W 210i.

In addition, lighting balloons are available to light up extensive parts of the construction site. At the end of the day, the first-class lighting system is a perfect addition when it comes to extending the working capacity of the W 210/W 210i.



# Machine transport without detours

## READY FOR OPERATION QUICKLY

Transport of the W 210/W 210i is easy, making sure that the machine is ready for operation again quickly on the next job location. The conveyor in folding design reduces the machine's overall transport length and permits the use of smaller transport vehicles.

The canopy can be lowered hydraulically for transport. Removable supplementary weights enable transport of the W 210/W 210i on vehicles with a low maximum permissible payload.

Strong loading and lashing lugs enable the machine to be safely lashed down on a trailer or loaded by crane. Our range of optional equipment features includes conveyor support legs for machine transport on a flatbed truck.

1 | *The folding conveyor reduces the machine's transport length.*

2 | *Transport on a flatbed truck with the canopy folded down - tailored to accurate fit!*





PROTECT THE ENVIRONMENT. WITHOUT COMPROMISING ON PERFORMANCE AND PRODUCTIVITY. THAT IS WHAT THE WIRTGEN W 210 /W 210i STANDS FOR. WITH WIDRIVE - THE INTELLIGENT MACHINE MANAGEMENT SYSTEM. WITH VCS - THE INNOVATIVE VACUUM CUTTING SYSTEM FOR DUST EXTRACTION. WITH THE DUAL ENGINE CONCEPT - TWO ENGINES FOR INCREASED EFFICIENCY. EFFECT: A SIGNIFICANT REDUCTION IN ENVIRONMENTAL EMISSION LEVELS.

Surpassing environmental

standards.



# Technical specification

46  
47

	W 210	W 210i
<b>Milling drum</b>		
Milling width standard	2,000 mm	
Milling width optional 1	1,500 mm	
Milling width optional 2	2,200 mm	
Milling depth *1	0-330 mm	
Drum diameter with tools	1,020 mm	
<b>Motor</b>		
Manufacturer	CUMMINS	
Type	QSL 8.9 + QSC 8.3	QSL 9 + QSL 9
Cooling	Water	
Number of cylinders	6 + 6	
Rated power at 2,100 min <sup>-1</sup>	470 kW/630 HP/639 PS	514 kW/689 HP/699 PS
Maximum power at 1,900 min <sup>-1</sup>	500 kW/671 HP/680 PS	537 kW/720 HP/730 PS
Operating power at 1,600 min <sup>-1</sup>	469 kW/628 HP/638 PS	494 kW/662 HP/672 PS
Displacement	17,2 l	18 l
Fuel consumption at rated power	131 l/h	136 l/h
Fuel consumption in field mix	52 l/h	54 l/h
Emission standards	EU Stage 3a/US Tier 3	EU Stage 4/US Tier 4f
<b>Electrical system</b>		
Electrical power supply	24 V	
<b>Tank capacities</b>		
Fuel tank	1,220 l	1,120 l
AdBlue®/DEF tank	-	100 l
Hydraulic oil tank	200 l	
Water tank	3,350 l	
<b>Driving properties</b>		
Max. travel and milling speed	0 to 85 m/min (5 km/h)	
<b>Track units</b>		
Track units, front and rear (L x W x H)	1,730 x 300 x 610 mm	
<b>Loading of the milled material</b>		
Belt width of primary conveyor	850 mm	
Belt width of discharge conveyor	850 mm	
Theoretical capacity of discharge conveyor	375 m <sup>3</sup> /h	

\*1 = The maximum milling depth may deviate from the value indicated due to tolerances and wear.

	W 210	W 210i
<b>Weight of base machine</b>		
Empty weight of machine excluding tank contents	26,600 kg	26,850 kg
Operating weight, CE* <sup>2</sup>	28,900 kg	29,150 kg
Maximum operating weight (full tanks, full range of equipment) in FB2200	36,050 kg	36,300 kg
<b>Weights of tank contents</b>		
Water tank filling	3,350 kg	3,350 kg
Diesel tank filling (0.83 kg/l)	1,000 kg	930 kg
AdBlue®/DEF tank filling (1.1 kg/l)	-	110 kg
<b>Additional add-on weights</b>		
<b>Driver and tools</b>		
Driver		75 kg
5 cutting tool containers		125 kg
On-board tools		30 kg
<b>Optional milling drum assemblies in lieu of standard</b>		
Milling drum housing, FB1500 mm		100 kg
Milling drum housing, FB2200 mm		200 kg
Milling drum housing, FB2000 mm, FCS-L		650 kg
Milling drum housing, FB2200 mm, FCS-L		900 kg
<b>Optional milling drums in lieu of standard</b>		
Milling drum, FB1500 mm, LA 15		-460 kg
Milling drum, FB2200 mm, LA 15		180 kg
<b>Optional FCS milling drums in lieu of standard</b>		
Milling drum, FB2000 mm, LA 6x2, FCS-L		960 kg
Milling drum, FB2000 mm, LA 8, FCS-L		660 kg
Milling drum, FB2000 mm, LA 15, FCS-L		-150 kg
Milling drum, FB2000 mm, LA 18, FCS-L		-260 kg
Milling drum, FB2200 mm, LA 6x2, FCS-L		1,060 kg
Milling drum, FB2200 mm, LA 8, FCS-L		900 kg
Milling drum, FB2200 mm, LA 15, FCS-L		0 kg
Milling drum, FB2200 mm, LA 18, FCS-L		-30 kg
<b>Optional additional equipment</b>		
Operator's platform including comfortable seats in lieu of standard		250 kg
Canopy in lieu of standard		280 kg
Cabin in lieu of standard		600 kg
Folding conveyor in lieu of standard		520 kg
VCS - Vacuum Cutting System		150 kg
Supplementary weight 1 for flexible use		1,700 kg

\*<sup>2</sup> = Weight of machine, half-full water tank, half-full fuel tank, driver (75 kg), on-board tools, excluding optional equipment features.

# Dimensions

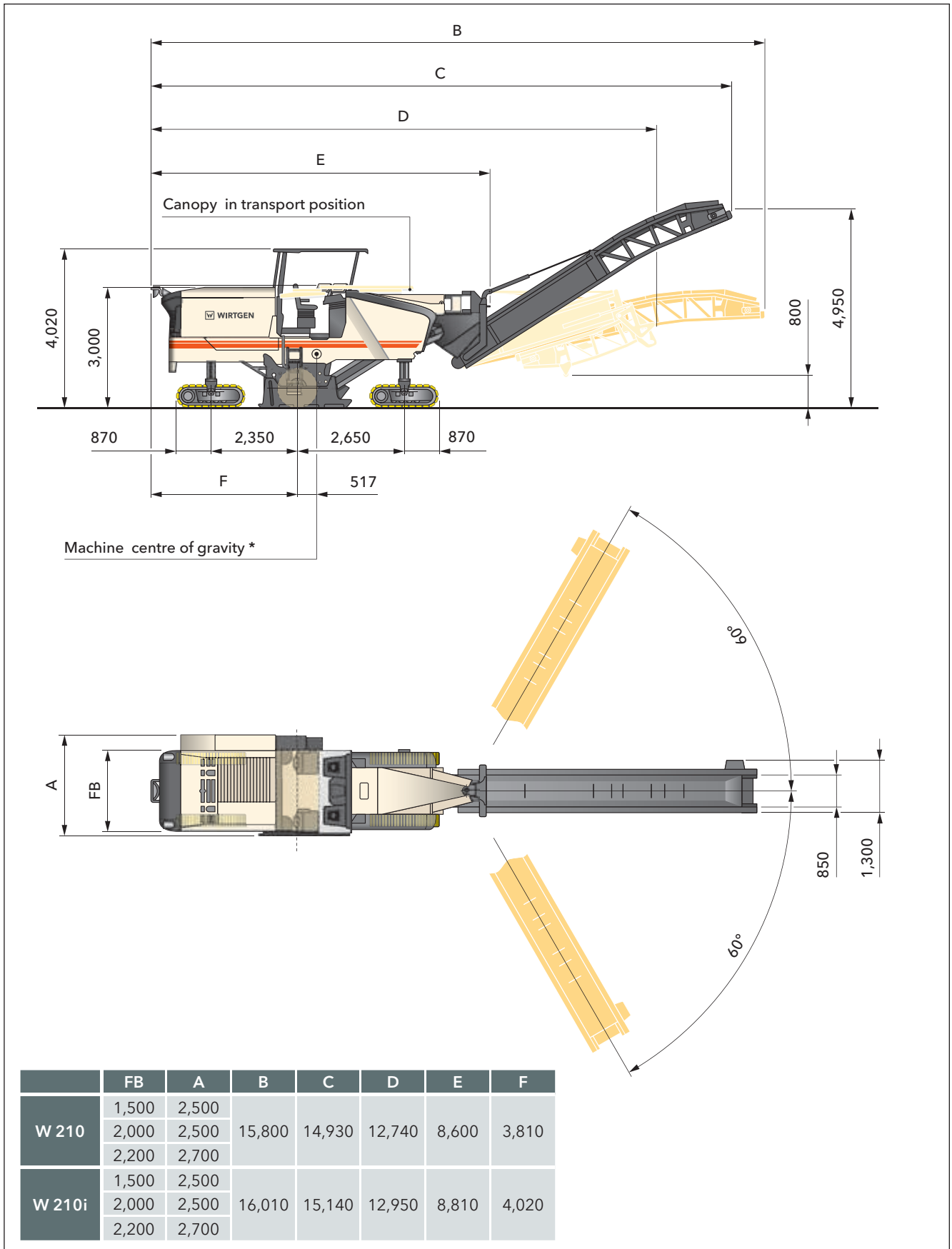

Dimensions in mm

\*Based on operating weight, CE with conveyor folded out



Milling radius, milling depth 150 mm, Dimensions in mm

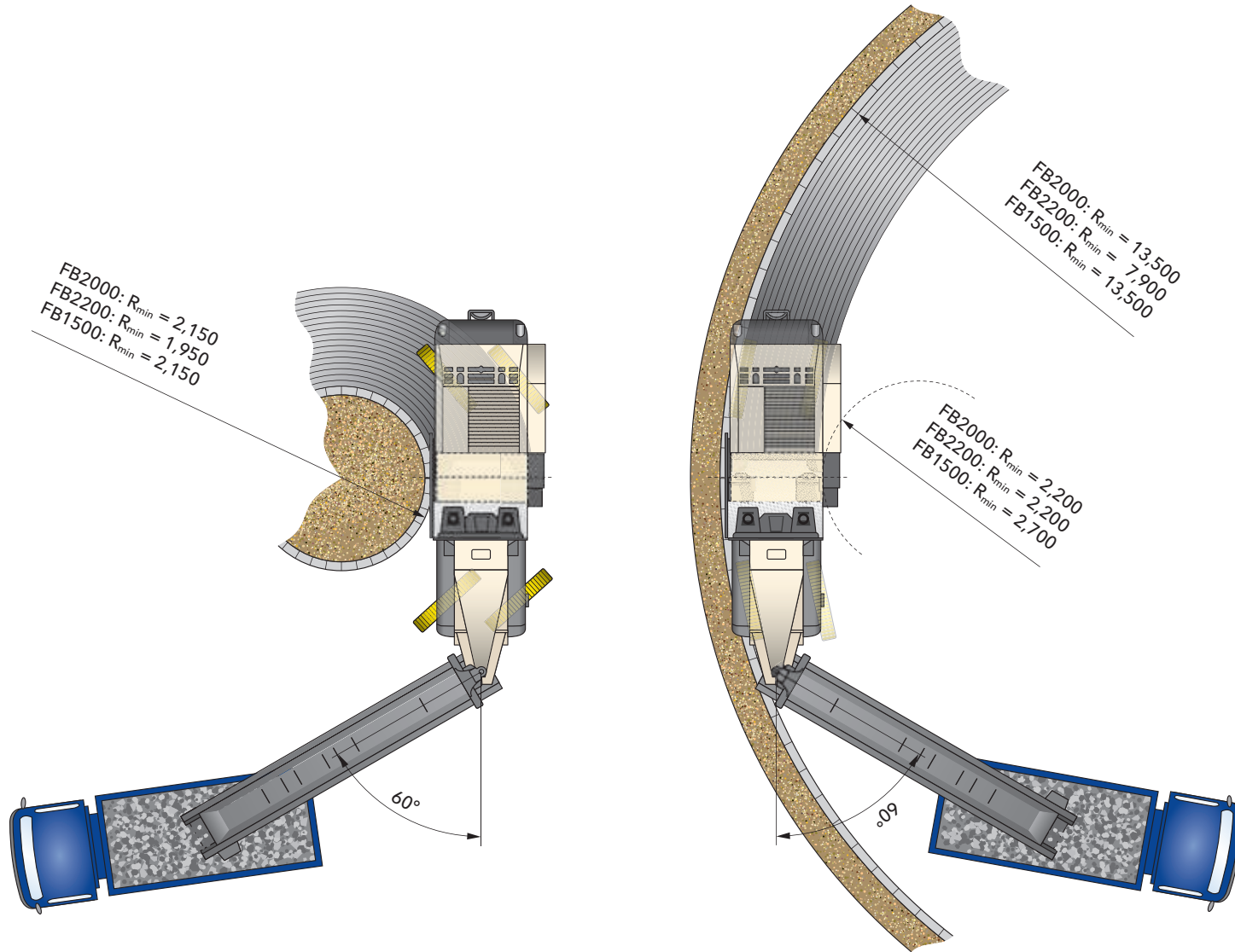

# Standard equipment

	W 210	W 210i
<b>Base machine</b>		
Basic machine with engine	■	■
Maschine chassis with double-sided wasp waist	■	■
Hydraulically opening engine cover with noise insulation	■	■
Air compressor system	■	■
Battery operated hydraulic unit for emergency functions	■	■
Cooling system with temperature-controlled fan speed	■	■
Large storage compartments for pick buckets	■	■
<b>Milling drum unit</b>		
Three milling drum rotation speeds with electric on/off function 127 r.p.m. - 109 r.p.m. - 97 r.p.m.	■	■
Hydraulic material depressor with conveyor lifting function	■	■
Hydraulically movable and positionable scraper plate with automatic locking	■	■
Hydraulically lifting side plate, right clearance 450 mm and left clearance 330 mm	■	■
Water sprinkling strip in the milling drum unit	■	■
Milling drum housing FB2000	□	□
<b>Milling drums</b>		
Milling drum FB2000 HT22 LA15 with 162 picks	□	□
<b>Milled-out material loading</b>		
Conveyor belt system with manually or automatically controllable transport speed	■	■
Water sprinkling system in the primary conveyor	■	■
Slewing angle discharge conveyor ± 60°	■	■
Discharge conveyor, 7,900 mm long, 850 mm wide	□	□
<b>Machine control and levelling system</b>		
Multi-function control display showing important machine operating conditions	■	■
Extensive machine diagnosis in the control display	■	■
Milling power control with automatic on/off function	■	■
Two exterior panels for operating functions by ground personnel	■	■
Milling depth regulation with LEVEL PRO levelling system, with one operating display as well as one electrical height sensor in the hydraulic cylinder right and left on side plate	■	■

- = Standard equipment
- = Standard equipment, replaceable with optional equipment
- = Optional equipment

	W 210	W 210i
<b>Operator's stand</b>		
Operator's stand with complete flexible mounting	■	■
Convenient, individually adjustable operating panel	■	■
Convenient footstep to the operator's stand, right and left	■	■
Covers for operating panels with lock	■	■
Operator's stand with single standing seats	□	□
Exterior mirror standard	□	□
<b>Under-carriage and height adjustment</b>		
PTS - machine automatically guided parallel with the road surface	■	■
ISC - intelligent track speed control with hydraulic four chain drive	■	■
High machine stability due to quadruple pendulum axle	■	■
Freely selectable steering functions for the four-track steering	■	■
Extremely wear-resistant, two-piece EPS polyurethane track pads	■	■
<b>Others</b>		
Lighting package with 5 halogen floodlights and 4 LED lights in the area of the milling unit	■	■
"Welcome" and "Go home" lights feature including LED lighting in the area of the operator's access and platform	■	■
Large tool package in lockable tool box	■	■
Total of 6 EMERGENCY STOP switches at sensible positions on the machine	■	■
Water high-pressure system with automatic on/off function, 18 bar, 67 l/min	■	■
Machine preparation for installing the control unit for WITOS FleetView	—	■
European type test certificate, Euro Test-mark and CE conformity	■	■
Water tank filling from rear of machine	□	□
Paint standard cream white RAL 9001	□	□
Halogen lighting package 24 V with rotary beacons	□	□

■ = Standard equipment  
 ■ = Standard equipment, replaceable with optional equipment  
 □ = Optional equipment

# Optional equipment

52  
53

	W 210	W 210i
<b>Milling drum unit</b>		
Milling drum housing FB2200	<input type="checkbox"/>	<input type="checkbox"/>
Milling drum housing FB1500	<input type="checkbox"/>	<input type="checkbox"/>
Milling drum housing FB2000 FCS-L	<input type="checkbox"/>	<input type="checkbox"/>
Milling drum housing FB2200 FCS-L	<input type="checkbox"/>	<input type="checkbox"/>
Milling drum housing FB1200 FCS	—	<input type="checkbox"/>
<b>Milling drums</b>		
Milling drum FB2200 HT22 LA15 with 174 picks	<input type="checkbox"/>	<input type="checkbox"/>
Milling drum FB1500 HT22 LA15 with 136 picks	<input type="checkbox"/>	<input type="checkbox"/>
Milling drum FB2000 HT22 LA15 FCS with 162 picks	<input type="checkbox"/>	<input type="checkbox"/>
Milling drum FB2000 HT22 LA18 FCS with 148 picks	<input type="checkbox"/>	<input type="checkbox"/>
Milling drum FB2200 HT22 LA15 FCS with 181 picks	<input type="checkbox"/>	<input type="checkbox"/>
Milling drum FB2200 HT22 LA18 FCS with 159 picks	<input type="checkbox"/>	<input type="checkbox"/>
Milling drum FB1200 HT22 LA15 FCS with 115 picks	—	<input type="checkbox"/>
Transport carriage for FCS milling drums from FB2000 to FB2200	<input type="checkbox"/>	<input type="checkbox"/>
Milling drum FB2000 HT22 LA8 with 274 picks	<input type="checkbox"/>	<input type="checkbox"/>
Milling drum FB2000 HT22 LA25 with 124 picks	<input type="checkbox"/>	<input type="checkbox"/>
Milling drum FB2000 HT5 LA6X2 with 672 picks	<input type="checkbox"/>	<input type="checkbox"/>
Milling drum FB2200 HT22 LA8 with 298 picks	<input type="checkbox"/>	<input type="checkbox"/>
Milling drum FB2200 HT22 LA25 with 134 picks	<input type="checkbox"/>	<input type="checkbox"/>
Milling drum FB2200 HT5 LA6X2 with 740 picks	<input type="checkbox"/>	<input type="checkbox"/>
Milling drum FB1500 HT22 LA8 with 210 picks	—	<input type="checkbox"/>
Milling drum FB1500 HT22 LA25 with 102 picks	<input type="checkbox"/>	<input type="checkbox"/>
Milling drum FB1500 HT5 LA6X2 with 512 picks	<input type="checkbox"/>	<input type="checkbox"/>
Milling drum FB2000 HT22 LA8 FCS with 274 picks	<input type="checkbox"/>	<input type="checkbox"/>
Milling drum FB2000 HT22 LA25 FCS with 124 picks	<input type="checkbox"/>	<input type="checkbox"/>
Milling drum FB2000 HT5 LA6X2 FCS with 672 picks	<input type="checkbox"/>	<input type="checkbox"/>
Milling drum FB2200 HT22 LA8 FCS with 298 picks	<input type="checkbox"/>	<input type="checkbox"/>
Milling drum FB2200 HT22 LA25 FCS with 134 picks	<input type="checkbox"/>	<input type="checkbox"/>
Milling drum FB2200 HT5 LA6X2 FCS with 740 picks	<input type="checkbox"/>	<input type="checkbox"/>
Milling drum FB600 HT22 LA15 FCS with 80 picks	—	<input type="checkbox"/>
Milling drum FB900 HT22 LA15 FCS with 102 picks	—	<input type="checkbox"/>
<b>Milled-out material loading</b>		
Discharge conveyor, 7,900 mm long, 850 mm wide, with hydraulic folding device	<input type="checkbox"/>	<input type="checkbox"/>
VCS extraction system	<input type="checkbox"/>	<input type="checkbox"/>
Supporting device discharge conveyor	<input type="checkbox"/>	<input type="checkbox"/>
<b>Machine control and levelling system</b>		
Sonic Ski sensor with connection cable	<input type="checkbox"/>	<input type="checkbox"/>
Levelling boom for scanning up to 4 m to the side of the machine	<input type="checkbox"/>	<input type="checkbox"/>
Hydraulic sensor for scanning ahead of the milling drum right	<input type="checkbox"/>	<input type="checkbox"/>
Hydraulic sensor for scanning ahead of the milling drum right + left	<input type="checkbox"/>	<input type="checkbox"/>

- = Standard equipment
- = Standard equipment, replaceable with optional equipment
- = Optional equipment

	W 210	W 210i
<b>Machine control and levelling system</b>		
Operating display LEVEL PRO	<input type="checkbox"/>	<input type="checkbox"/>
Multiplex preliminary equipment comprising 4 sensor sockets	<input type="checkbox"/>	<input type="checkbox"/>
Multiplex 3-way right with 2 ultrasonic sensors, including Multiplex preliminary equipment	<input type="checkbox"/>	<input type="checkbox"/>
Multiplex 3-way right + left with 4 ultrasonic sensors, including Multiplex preliminary equipment	<input type="checkbox"/>	<input type="checkbox"/>
Basic equipment laser levelling without laser transmitter	<input type="checkbox"/>	<input type="checkbox"/>
Level control 3D levelling pre-equipment	<input type="checkbox"/>	<input type="checkbox"/>
Slope control sensor	<input type="checkbox"/>	<input type="checkbox"/>
Milling depth measurement and display in the LEVEL PRO display	<input type="checkbox"/>	<input type="checkbox"/>
<b>Operator's stand</b>		
Operator's stand with large storage compartment and single standing seats	<input type="checkbox"/>	<input type="checkbox"/>
Operator's stand with comfort seat package	<input type="checkbox"/>	<input type="checkbox"/>
Operator's stand with cabin "Operator Comfort System"	<input type="checkbox"/>	<input type="checkbox"/>
Exterior mirror folding with signal lights	<input type="checkbox"/>	<input type="checkbox"/>
Weather canopy folds in electrohydraulically	<input type="checkbox"/>	<input type="checkbox"/>
Hot air heating footwell of the operator's stand	<input type="checkbox"/>	<input type="checkbox"/>
Monitor system with 2 cameras	<input type="checkbox"/>	<input type="checkbox"/>
Monitor system with 6 cameras and additional monitor	<input type="checkbox"/>	<input type="checkbox"/>
<b>Others</b>		
Water tank filling with hydraulic filling pump	<input type="checkbox"/>	<input type="checkbox"/>
Paint in one special colour (RAL)	–	<input type="checkbox"/>
Paint in two special colours (RAL)	<input type="checkbox"/>	<input type="checkbox"/>
Paint in maximum two special colours with substructure in special colour (RAL)	<input type="checkbox"/>	<input type="checkbox"/>
Powerful LED lighting package 24 V with rotary beacons	<input type="checkbox"/>	<input type="checkbox"/>
Additional weight 1,700 kg	<input type="checkbox"/>	<input type="checkbox"/>
Large storage compartment on rear of machine	<input type="checkbox"/>	<input type="checkbox"/>
Electric preheating of the fuel filter	–	<input type="checkbox"/>
Electrical power set 220 V, 4 kW	<input type="checkbox"/>	<input type="checkbox"/>
Electrical power set 110 V, 4 kW	<input type="checkbox"/>	<input type="checkbox"/>
High-pressure water cleaner, 150 bar 15 l/min	<input type="checkbox"/>	<input type="checkbox"/>
Milling drum rotation device	<input type="checkbox"/>	<input type="checkbox"/>
Hydraulic pick ejector drift	<input type="checkbox"/>	<input type="checkbox"/>
Pneumatic hammer with pick ejector/insertor	<input type="checkbox"/>	<input type="checkbox"/>
Additional seats for pick change with storage compartment	<input type="checkbox"/>	<input type="checkbox"/>
Diesel tank filling pump with 5.0 m suction hose	<input type="checkbox"/>	<input type="checkbox"/>
Illumination balloon 220 volt	<input type="checkbox"/>	<input type="checkbox"/>
Illumination balloon 110 volt	<input type="checkbox"/>	<input type="checkbox"/>
WITOS FleetView telematics system incl. 3-year operating period (EU)	–	<input type="checkbox"/>
WITOS FleetView telematics system incl. 3-year operating period (USA)	–	<input type="checkbox"/>
WITOS FleetView telematics system incl. 3-year operating period - PROMOTION	–	<input type="checkbox"/>

- = Standard equipment
- = Standard equipment, replaceable with optional equipment
- = Optional equipment





WIRTGEN

W WIRTGEN





WIRTGEN GmbH  
Reinhard-Wirtgen-Str. 2 · 53578 Windhagen · Germany  
Phone: +49 (0)26 45/131-0 · Fax: +49 (0)26 45/131-392  
Internet: [www.wirtgen.com](http://www.wirtgen.com) · E-Mail: [info@wirtgen.com](mailto:info@wirtgen.com)

