

Slewing tower crane

WOLFF 5014 city

Technical Informations

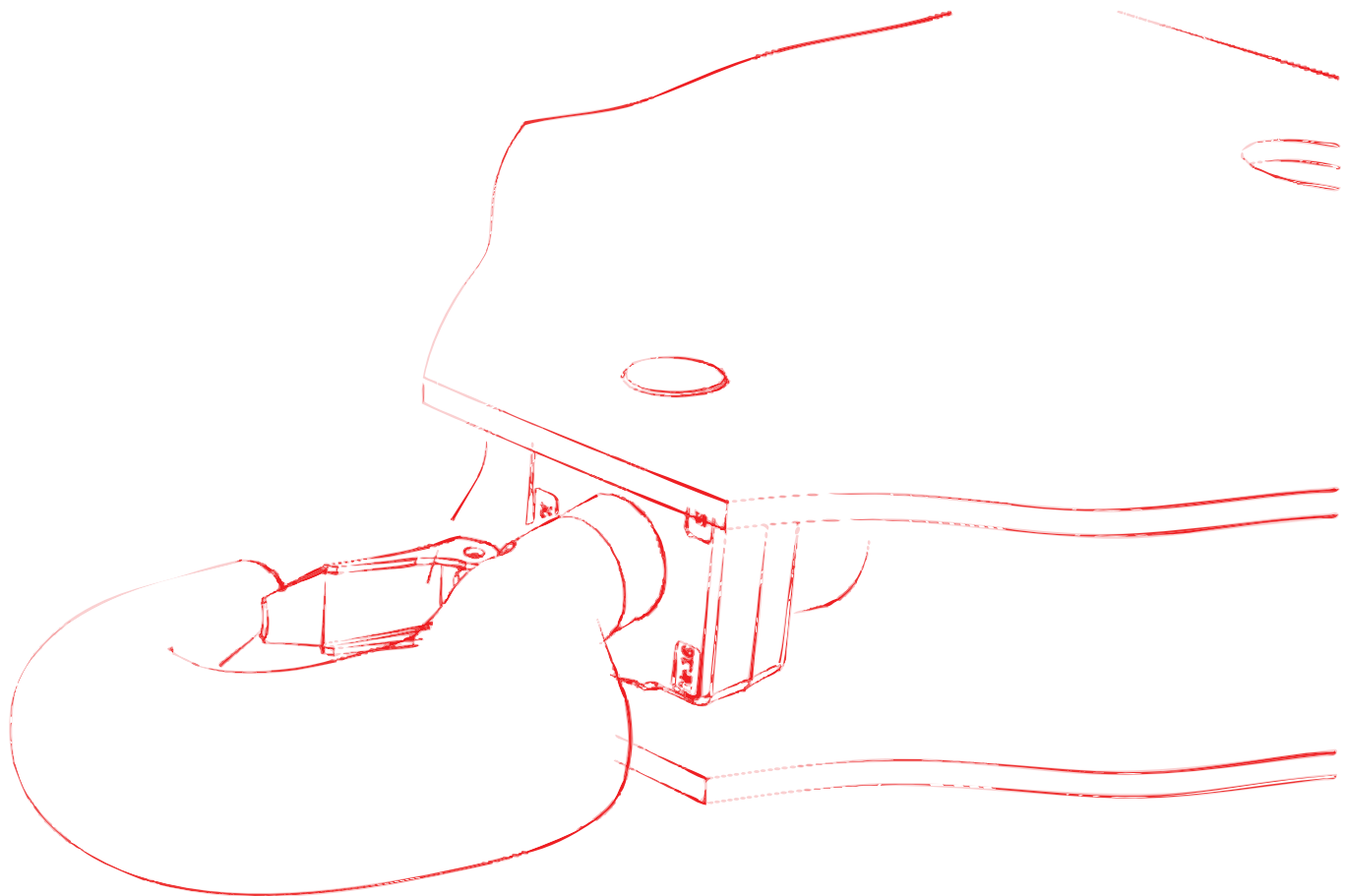

English

English



*Published by*

**WOLFFKRAN GmbH**

Austraße 72

74076 Heilbronn

Germany

Phone +49 7131 9815 0

Fax +49 7131 9815 355

[www.wolffkran.com](http://www.wolffkran.com)

[info@wolffkran.de](mailto:info@wolffkran.de)

#### Copyright

This documentation including all of its subsections is protected by copyright laws.

Any type of use or modification outside of the stringent limits of the copyright laws without permission of WOLFFKRAN GmbH is prohibited and subject to penalties.

This applies particularly for copying, translation, microfilming and storage and processing in electronic systems.

At the time of printing, the information, data, illustrations and notes comprised in this manual were up-to-date.

Subject to change of design, error and typos.

Stand:

## Table of contents

1	Schedule drawing	5
1.1	Schedule drawing WOLFF 5014 city	5
2	Load carrying capacities	6
2.1	Table of load carrying capacity WOLFF 5014 city (6.0 t, 2 fall operation)	6
2.2	Table of load carrying capacities (kg) in meter intervals, WOLFF 5014 city (6.0 t, 2-fall mode)	7
3	Tower combinations	8
3.1	Tower combinations on foundation anchor (slewing section with TFS 15 - connection)	9
3.2	Tower combinations on cross frame (slewing section with TFS 15 - connection)	12
3.3	Tower combinations on supporting frame (slewing section with TFS 15 - connection)	16
3.4	Tower combinations on cross frame element (slewing section with TFS 15 - connection)	17
3.5	Tower combinations on city portal (slewing section with TFS 15 - connection)	19
3.6	Tower combinations on mobile cross frame (slewing section with TFS 15 - connection)	20
3.7	Tower combinations on undercarriage (slewing section with TFS 15 - connection)	22
4	Foundation loads / central ballast weights / corner loads in compliance with EN 14439 / EN 13001	24
4.1	Foundation loads jib 25 m - 50 m	26
5	Operating speeds	27
6	Package list	28
6.1	Package list 5014	28
7	Assembly weights	30
7.1	Counterweight blocks	30
7.1.1	Counterweight block, 1.8 t	31
7.2	Total weight jib assembly	32
7.3	Assembly weight slewing gear	33
7.4	Assembly weight cross frame	34
7.5	Assembly weight supporting frame	36
7.6	Assembly weight cross frame elements	37
7.7	Assembly weight undercarriage	38

7.8	Assembly weights travelling cross frame	39
7.9	Assembly weights city portal	41
7.10	Hook height above ground required for mobile cranes	42
8	Assembly diagrams	43
8.1	Jib attachment diagram	43
8.1.1	Divided jib assembly	44
8.1.1.1	Trolley jib - attachment diagram 50.0 m to 45.0 m	45
8.1.1.2	Trolley jib - attachment diagram 42.5 m to 37.5 m	46
8.1.1.3	Trolley jib - attachment diagram 35.0 m to 30.0 m	47
8.1.1.4	Trolley jib - attachment diagram 27.5 m to 25.0 m	48
8.1.2	Assembly of the entire jib without counterjib	49
8.1.2.1	Trolley jib - attachment diagram 50.0 m to 45.0 m	49
8.1.2.2	Trolley jib - attachment diagram 42.5 m to 37.5 m	50
8.1.2.3	Trolley jib - attachment diagram 35.0 m to 30.0 m	51
8.1.2.4	Trolley jib - attachment diagram 27.5 m to 25.0 m	52
8.1.3	Assembly of the entire jib with counterjib	53
8.1.3.1	Trolley jib - attachment diagram 50.0 m to 45.0 m	53
8.1.3.2	Trolley jib - attachment diagram 42.5 m to 37.5 m	54
8.1.3.3	Trolley jib - attachment diagram 35.0 m to 30.0 m	55
8.1.3.4	Trolley jib - attachment diagram 27.5 m to 25.0 m	56
8.2	Counterjib lifting diagram	57
8.3	Counterjib brace diagram	58
8.4	Trolley jib assembly brackets	59
8.5	Arrangement of standard railings	60
8.5.1	Standard railings (NG) and accessories	60
8.5.2	Arrangement of standard railings	61
9	Suitable climbing devices	63
9.1	Outer climbing devices	64
9.1.1	Outer climbing device KWH 15.2	65
9.2	Inner climbing devices	66
9.2.1	Inner climbing device KSH 15	67
10	Arrangement of counterweight blocks	70

## 1 Schedule drawing

### 1.1 Schedule drawing WOLFF 5014 city

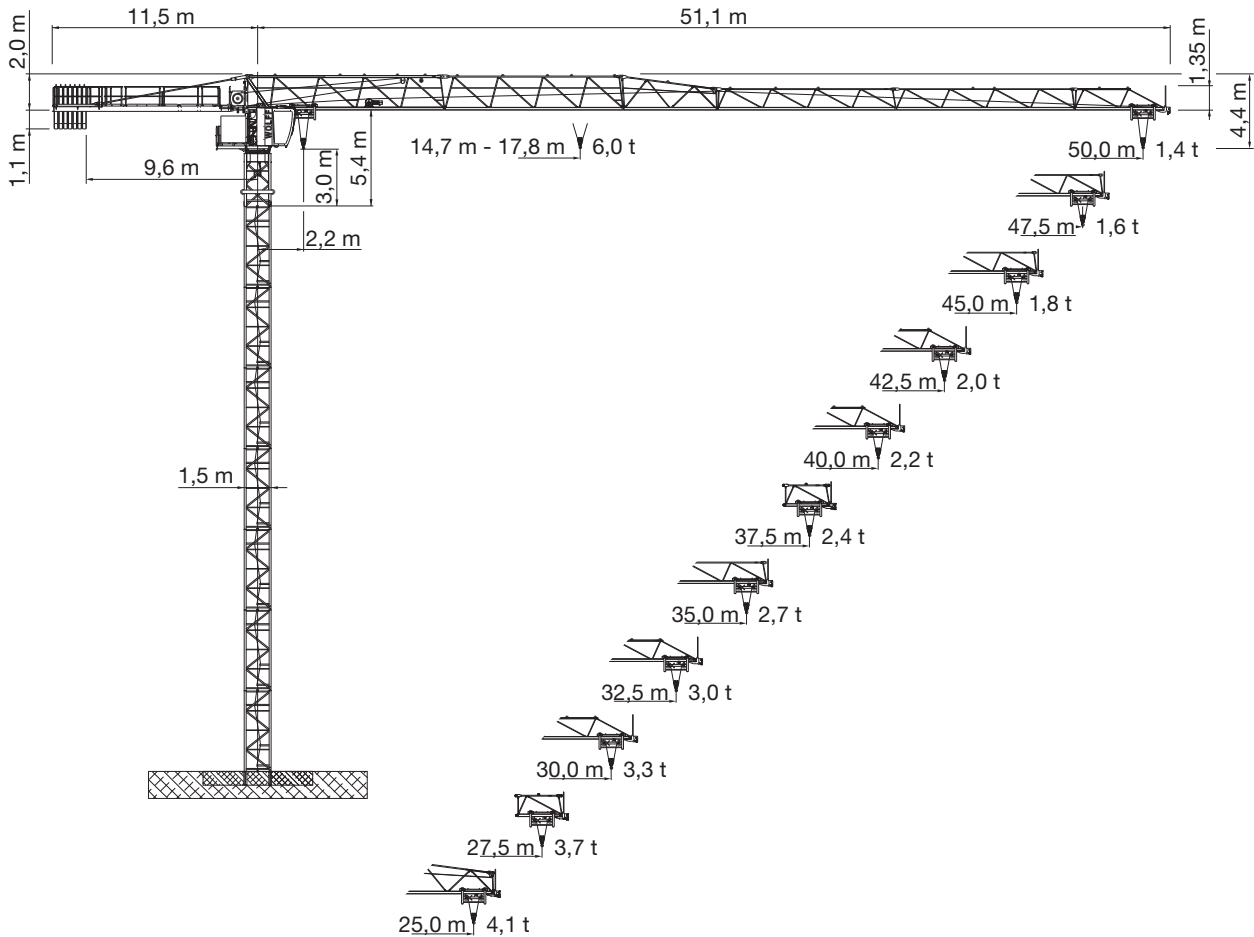

Item	Data
Crane type	BGL GROUP C.0.10.0080
Design	Overhead travelling crane with top slewing trolley jib, with climbing feature
Type of setup	Stationary or travelling
Basis of calculation	EN
Payload torque	max. 1060 kNm
Hoist winch	Hw 628.1 FU

## 2 Load carrying capacities

## 2 Load carrying capacities

### 2.1 Table of load carrying capacity WOLFF 5014 city (6.0 t, 2 fall operation)

 6.0 t		Operating radius [m]	15.0	20.0	25.0	27.5	30.0	32.5	35.0	37.5	40.0	42.5	45.0	47.5	50.0	LCC [t]
			JL [m]													
JL [m]	50.0	2.2 - 14.7	5.9	4.3	3.3	3.0	2.7	2.4	2.2	2.0	1.9	1.7	1.6	1.5	1.4	
	47.5	2.2 - 15.4	6.0	4.5	3.5	3.1	2.8	2.6	2.4	2.2	2.0	1.9	1.7	1.6		
	45.0	2.2 - 16.0	6.0	4.7	3.7	3.3	3.0	2.7	2.5	2.3	2.1	1.9	1.8			
	42.5	2.2 - 16.4	6.0	4.8	3.8	3.4	3.1	2.8	2.5	2.3	2.2	2.0				
	40.0	2.2 - 16.7	6.0	4.9	3.8	3.4	3.1	2.8	2.6	2.4	2.2					
	37.5	2.2 - 16.8	6.0	5.0	3.9	3.5	3.1	2.9	2.6	2.4						
	35.0	2.2 - 17.3	6.0	5.1	4.0	3.6	3.2	3.0	2.7							
	32.5	2.2 - 17.5	6.0	5.2	4.1	3.6	3.3	3.0								
	30.0	2.2 - 17.6	6.0	5.2	4.1	3.7	3.3									
	27.5	2.2 - 17.8	6.0	5.3	4.1	3.7										
	25.0	2.2 - 17.7	6.0	5.3	4.1											

Caption	
JL	Jib length
LCC	Load carrying capacity



The load carrying capacity is related to a hook range of 42.0 m. Hook ranges greater than that reduce the maximum load carrying capacity by the weight of the additional hoisting rope.

### 2.2 Table of load carrying capacities (kg) in meter intervals, WOLFF 5014 city (6.0 t, 2-fall mode)

Operating radius [m]	Jib length [m]										
	25	27.5	30	32.5	35	37.5	40	42.5	45	47.5	50
10	6000	6000	6000	6000	6000	6000	6000	6000	6000	6000	6000
11	6000	6000	6000	6000	6000	6000	6000	6000	6000	6000	6000
12	6000	6000	6000	6000	6000	6000	6000	6000	6000	6000	6000
13	6000	6000	6000	6000	6000	6000	6000	6000	6000	6000	6000
14	6000	6000	6000	6000	6000	6000	6000	6000	6000	6000	6000
15	6000	6000	6000	6000	6000	6000	6000	6000	6000	6000	5860
16	6000	6000	6000	6000	6000	6000	6000	6000	5990	5750	5460
17	6000	6000	6000	6000	6000	5910	5870	5770	5600	5390	5110
18	5890	5920	5840	5830	5730	5550	5510	5420	5270	5060	4800
19	5560	5580	5510	5490	5400	5230	5200	5100	4960	4770	4520
20	5250	5280	5210	5190	5110	4950	4910	4820	4690	4500	4270
21	4980	5000	4930	4920	4840	4690	4650	4570	4440	4260	4040
22	4730	4750	4690	4680	4600	4450	4420	4340	4220	4050	3830
23	4500	4520	4460	4450	4370	4230	4200	4130	4010	3850	3640
24	4290	4310	4250	4240	4170	4040	4010	3930	3820	3670	3470
<b>25</b>	<b>4100</b>	<b>4120</b>	<b>4060</b>	<b>4050</b>	<b>3980</b>	<b>3860</b>	<b>3830</b>	<b>3760</b>	<b>3650</b>	<b>3500</b>	<b>3310</b>
26		3940	3890	3880	3810	3690	3660	3590	3490	3340	3160
27		3780	3720	3720	3650	3530	3500	3440	3340	3200	3030
<b>27.5</b>		<b>3700</b>	<b>3650</b>	<b>3640</b>	<b>3580</b>	<b>3460</b>	<b>3430</b>	<b>3370</b>	<b>3270</b>	<b>3130</b>	<b>2960</b>
28			3570	3560	3500	3390	3360	3300	3200	3070	2900
29			3430	3420	3360	3250	3230	3170	3070	2950	2780
<b>30</b>			<b>3300</b>	<b>3290</b>	<b>3240</b>	<b>3130</b>	<b>3100</b>	<b>3050</b>	<b>2960</b>	<b>2830</b>	<b>2670</b>
31				3170	3110	3010	2990	2930	2840	2720	2570
32				3050	3000	2900	2880	2820	2740	2620	2470
<b>32.5</b>				<b>3000</b>	<b>2950</b>	<b>2850</b>	<b>2830</b>	<b>2770</b>	<b>2690</b>	<b>2570</b>	<b>2430</b>
33					2890	2800	2770	2720	2640	2530	2380
34					2790	2700	2680	2630	2550	2440	2300
<b>35</b>					<b>2700</b>	<b>2610</b>	<b>2590</b>	<b>2540</b>	<b>2460</b>	<b>2350</b>	<b>2220</b>
36						2520	2500	2450	2380	2270	2140
37						2440	2420	2370	2300	2200	2070
<b>37.5</b>						<b>2400</b>	<b>2380</b>	<b>2330</b>	<b>2260</b>	<b>2160</b>	<b>2040</b>
38							2340	2300	2230	2130	2000
39							2270	2230	2160	2060	1940
<b>40</b>							<b>2200</b>	<b>2160</b>	<b>2090</b>	<b>2000</b>	<b>1880</b>
41								2090	2030	1930	1820
42								2030	1970	1880	1760
<b>42.5</b>								<b>2000</b>	<b>1940</b>	<b>1850</b>	<b>1740</b>
43									1910	1820	1710
44									1850	1770	1660
<b>45</b>									<b>1800</b>	<b>1720</b>	<b>1610</b>
46										1670	1570
47										1620	1520
<b>47.5</b>										<b>1600</b>	<b>1500</b>
48											1480
49											1440
<b>50</b>											<b>1400</b>

## 3 Tower combinations

### 3 Tower combinations

	<p><b>⚠ DANGER</b></p> <p>Usage of incorrect tower combinations. The slewing tower crane may overturn.</p> <ol style="list-style-type: none"><li>1) Use the specified tower combinations.</li><li>2) If you need another tower combination that is not specified here, please contact WOLFFKRAN to get an approved alternative setup in writing.</li></ol>
	<p><b>NOTICE</b></p> <p>All tower combinations apply to free standing slewing tower cranes without climbing gear.</p>
	<p><b>NOTICE</b></p> <p>For tower combination with tower element TV 25 and UV 25 please contact WOLFFKRAN.</p>



## 3.1 Tower combinations on foundation anchor (slewing section with TFS 15 - connection)

Jib length		25 m – 50 m			
Item					
1	4.5 m	TFS 15	TFS 15	TFS 15	TFS 15
2	9.0 m	TFS 15	TFS 15	TFS 15	TFS 15
3	13.5 m	TFS 15	TFS 15	TFS 15	TFS 15
4	18.0 m	TFS 15	TFS 15	TFS 15	TFS 15
5	22.5 m	TFS 15	TFS 15	TFS 15	TFS 15
6	27.0 m	TFS 15	TFS 15.4	TFS 15.4	TFS 15.4
7	31.5 m	TFS 15.4	TFS 15.4	TFS 15.4	TFS 15.4
8	36.0 m	TFS 15.4	TFS 15.4	TFS 15.4	UVA 15.4
9	40.5 m	TFS 15.4	UVA 15.4	UVA 15.4	UV 15.4
10	45.0 m		UV 15.4	UV 15.4	UVÜ 15.4
11	49.5 m		UV 15.4	UVÜ 15.4	UV 20.4
12	54.0 m			UV 20.4	UV 20.4
13	58.5 m			UV 20.4	TVA 20.4
14	63.0 m				TV 20.4
15	67.5 m				TV 20.4
16	72.0 m				TV 20.4
17	76.5 m				TV 20.4
Foundation anchors		FUA B.4 FUA 93	FUA 120 / Type C-120	FUA 120 / Type C-120	FUA 140 / Type D-140
Tower height [m]		40.5	49.5	58.5	76.5
Hook height double reeving [m]		43.5	52.5	61.5	79.5
Wind category		C25			

## 3 Tower combinations

Jib length	25 m – 50 m			
Item				
1	4.5 m	TFS 15	TFS 15	
2	9.0 m	TFS 15	TFS 15	
3	13.5 m	TFS 15	TFS 15	
4	18.0 m	TFS 15	TFS 15	
5	22.5 m	TFS 15	TFS 15.4	
6	27.0 m	TFS 15.4	TFS 15.4	
7	31.5 m	TFS 15.4	TFS 15.4	
8	36.0 m	UVA 15.4	UVA 15.4	
9	40.5 m	UV 15.4	UV 15.4	
10	45.0 m	UVÜ 15.4	UVÜ 15.4	
11	49.5 m	UV 20.4	UV 20.4	
12	54.0 m	UV 20.4	TVA 20.4	
13	58.5 m	TVA 20.4	TV 20.4	
14	63.0 m	TV 20.4	TV 20.4	
15	67.5 m	TV 20.4	TV 20.4	
16	72.0 m	TV 20.4	TV 20.4	
17	73.0 m	VR 2023	VR 2023	
18	77.5 m	TV 23	TV 23	
19	82.0 m	TV 23	HTA 23	
20	86.5 m		HT 23	
21	91.0 m		HT 23	
22	95.5 m		HT 23	
Foundation anchors		FUA 140 / Type D-140	FUA G 160	
Tower height [m]		82.0	95.5	
Hook height double reeving [m]		85.0	98.5	
Wind category		C25		

Jib length	25 m – 50 m				
Item					
1	4.5 m	TFS 15			
2	9.0 m	TFS 15			
3	13.5 m	TFS 15			
4	18.0 m	TFS 15			
5	22.5 m	TFS 15.4			
6	27.0 m	TFS 15.4			
7	31.5 m	UVA 15.4			
8	36.0 m	UV 15.4			
9	40.5 m	UVÜ 15.4			
10	45.0 m	UV 20.4			
11	49.5 m	UV 20.4			
12	54.0 m	TVA 20.4			
13	58.5 m	TV 20.4			
14	63.0 m	TV 20.4			
15	67.5 m	TV 20.4			
16	68.5 m	VR 2023			
17	73.0 m	TV 23			
18	77.5 m	HTA 23			
19	82.0 m	HT 23			
20	86.5 m	HT 23			
21	91.0 m	HT 23			
22	102.3 m	BT 23			
Foundation anchors		FUA G 210			
Tower height [m]		102.3			
Hook height double reeving [m]		105.3			
Wind category					C25

## 3 Tower combinations

### 3.2 Tower combinations on cross frame (slewing section with TFS 15 - connection)

Jib length	25 m – 50 m				
Item					
1	4.5 m	TFS 15	TFS 15	TFS 15	TFS 15
2	9.0 m	TFS 15	TFS 15	TFS 15	TFS 15
3	13.5 m	TFS 15	TFS 15	TFS 15	TFS 15
4	18.0 m	TFS 15	TFS 15	TFS 15	TFS 15
5	22.5 m	TFS 15	TFS 15	TFS 15	TFS 15
6	27.0 m		TFS 15	TFS 15	TFS 15
7	31.5 m			TFS 15.4	TFS 15.4
8	36.0 m				TFS 15.4
Substructure		KR HEB 700-4	KR HEB 700-5	KR 6-40	KR 7-32 KRV 7-32
Corner distance [m x m]		4.0 x 4.0	5.0 x 5.0	4.0 x 4.0	3.2 x 3.2
Substructure height [m]		0.8	0.8	0.7	0.8
Tower height [m]		23.3	27.8	32.2	36.8
Hook height double reeving [m]		26.3	30.8	35.2	39.8
Wind category		C25			

Jib length	25 m – 50 m				
Item					
1	4.5 m	TFS 15	TFS 15	TFS 15	TFS 15
2	9.0 m	TFS 15	TFS 15	TFS 15	TFS 15
3	13.5 m	TFS 15	TFS 15	TFS 15	TFS 15
4	18.0 m	TFS 15	TFS 15	TFS 15	TFS 15
5	22.5 m	TFS 15	TFS 15	TFS 15	TFS 15
6	27.0 m	TFS 15	TFS 15	TFS 15	TFS 15.4
7	31.5 m	TFS 15.4	TFS 15.4	TFS 15.4	TFS 15.4
8	36.0 m	TFS 15.4	TFS 15.4	UVA 15.4	TFS 15.4
9	40.5 m	TFS 15.4	UVA 15.4	UVÜ 15.4	UVA 15.4
10	45.0 m				UV 15.4
11	49.5 m				UVÜ 15.4
12	54.0 m				UV 20.4
13	58.5 m				UV 20.4
14	63.0 m				TVA 20.4
Substructure		KRV 7-32/46 KR 8-46	KR 800-5	KR 800-6	KR 10-46 KR 10-46/60
Corner distance [m x m]		4.6 x 4.6	5.0 x 5.0	6.0 x 6.0	4.6 x 4.6 6.0 x 6.0
Substructure height [m]		0.9	0.9	0.9	1.2
Tower height [m]		41.4	41.4	41.4	64.2
Hook height double reeving [m]		44.4	44.4	44.4	67.2
Wind category		C25			

## 3 Tower combinations

Jib length	25 m – 50 m			
Item				
1	4.5 m	TFS 15	TFS 15	
2	9.0 m	TFS 15	TFS 15	
3	13.5 m	TFS 15	TFS 15	
4	18.0 m	TFS 15	TFS 15	
5	22.5 m	TFS 15	TFS 15	
6	27.0 m	TFS 15.4	TFS 15.4	
7	31.5 m	TFS 15.4	TFS 15.4	
8	36.0 m	UVA 15.4	UVA 15.4	
9	40.5 m	UV 15.4	UV 15.4	
10	45.0 m	UVÜ 15.4	UVÜ 15.4	
11	49.5 m	UV 20.4	UV 20.4	
12	54.0 m	UV 20.4	UV 20.4	
13	58.5 m	TVA 20.4	TVA 20.4	
14	63.0 m	TV 20.4	TV 20.4	
15	67.5 m	TV 20.4	TV 20.4	
16	72.0 m	TV 20.4	TV 20.4	
17	76.5 m		TV 20.4	
Substructure		KRV 10-60	KR 12-60 KR 12-60/80	
Corner distance [m x m]		5.0 x 5.0 6.0 x 6.0	6.0 x 6.0 8.0 x 8.0	
Substructure height [m]		1.2	1.4	
Tower height [m]		73.2	77.9	
Hook height double reeving [m]		76.2	80.9	
Wind category	C25			

Jib length		25 m – 50 m			
Item					
1	4.5 m	TFS 15	TFS 15		
2	9.0 m	TFS 15	TFS 15		
3	13.5 m	TFS 15	TFS 15		
4	18.0 m	TFS 15	TFS 15		
5	22.5 m	TFS 15	TFS 15		
6	27.0 m	TFS 15.4	TFS 15.4		
7	31.5 m	TFS 15.4	TFS 15.4		
8	36.0 m	UVA 15.4	UVA 15.4		
9	40.5 m	UV 15.4	UV 15.4		
10	45.0 m	UVÜ 15.4	UVÜ 15.4		
11	49.5 m	UV 20.4	UV 20.4		
12	54.0 m	UV 20.4	TVA 20.4		
13	58.5 m	TVA 20.4	TV 20.4		
14	63.0 m	TV 20.4	TV 20.4		
15	67.5 m	TV 20.4	TV 20.4		
16	72.0 m	TV 20.4	TV 20.4		
17	73.0 m	VR 2023	VR 2023		
18	77.5 m	TV 23	TV 23		
19	82.0 m	TV 23	TV 23		
20	86.5 m		HTA 23		
Substructure		KR 12-60	KR 12-60/80		
Corner distance [m x m]		6.0 x 6.0	8.0 x 8.0		
Substructure height [m]		1.4	1.4		
Tower height [m]		83.4	87.9		
Hook height double reeving [m]		86.4	90.9		
Wind category		C25			

## 3 Tower combinations

### 3.3 Tower combinations on supporting frame (slewing section with TFS 15 - connection)

Jib length	25 m – 50 m				
Item					
1	4.5 m	TFS 15			
2	9.0 m	TFS 15			
3	13.5 m	TFS 15			
4	18.0 m	TFS 15			
5	22.5 m	TFS 15			
6	27.0 m	TFS 15			
7	31.5 m	TFS 15.4			
Substructure		SF 150			
Corner distance [m x m]		4.0 x 4.0			
Substructure height [m]		1.0			
Tower height [m]		32.5			
Hook height double reeving [m]		35.5			
Wind category		C25			



## 3.4 Tower combinations on cross frame element (slewing section with TFS 15 - connection)

Jib length		25 m – 50 m			
Item					
1	4.5 m	TFS 15	TFS 15	TFS 15	TFS 15
2	9.0 m	TFS 15	TFS 15	TFS 15	TFS 15
3	13.5 m	TFS 15	TFS 15	TFS 15	TFS 15
4	18.0 m	TFS 15	TFS 15	TFS 15	TFS 15
5	22.5 m	TFS 15	TFS 15	TFS 15	TFS 15
6	27.0 m	TFS 15	TFS 15	TFS 15	TFS 15
7	31.5 m	UVA 15.4	TFS 15.4	UVA 15.4	TFS 15.4
8	36.0 m		UVA 15.4	UVÜ 15.4	UVA 15.4
9	40.5 m				UVÜ 15.4
Substructure		KRE 250	KRE 250	KRE 260.1	KRE 260.1
Corner distance [m x m]		4.5 x 5.44	5.0 x 5.0	5.0 x 6.79	6.0 x 6.0
Substructure height [m]		4.0	4.0	4.0	4.0
Tower height [m]		35.5	40.0	40.0	44.5
Hook height double reeving [m]		38.5	43.0	43.0	47.5
Wind category		C25			

## 3 Tower combinations

Jib length	25 m – 50 m				
Item					
1	4.5 m	TFS 15	TFS 15		
2	9.0 m	TFS 15	TFS 15		
3	13.5 m	TFS 15	TFS 15		
4	18.0 m	TFS 15	TFS 15		
5	22.5 m	TFS 15	TFS 15		
6	27.0 m	TFS 15	TFS 15.4		
7	31.5 m	TFS 15.4	TFS 15.4		
8	36.0 m	UVA 15.4	TFS 15.4		
9	40.5 m	UVÜ 15.4	UVA 15.4		
10	45.0 m	TVA 20.4	UV 15.4		
11	49.5 m		UVÜ 15.4		
12	54.0 m		TVA 20.4		
Substructure		KRE 260.2	KRE 260.2		
Corner distance [m x m]		5.0 x 6.79	6.0 x 6.0		
Substructure height [m]		4.0	4.0		
Tower height [m]		49.0	58.0		
Hook height double reeving [m]		52.0	61.0		
Wind category		C25			

## 3.5 Tower combinations on city portal (slewing section with TFS 15 - connection)

Jib length	25 m – 50 m				
Item					
1	4.5 m	TFS 15	TFS 15		
2	9.0 m	TFS 15	TFS 15		
3	13.5 m	TFS 15	TFS 15		
4	18.0 m	TFS 15	TFS 15		
5	22.5 m	TFS 15	TFS 15		
6	27.0 m	TFS 15	TFS 15.4		
7	31.5 m	TFS 15.4	TFS 15.4		
8	36.0 m	TFS 15.4	TFS 15.4		
9	40.5 m		UVA 15.4		
10	45.0 m		UV 15.4		
11	49.5 m		UVÜ 15.4		
12	54.0 m		UV 20.4		
13	58.5 m		UV 20.4		
Substructure		CP 380	CP 520		
Corner distance [m x m]		3.8 x 3.8	5.24 x 5.24		
Substructure height [m]		5.3	5.8		
Tower height [m]		41.3	64.3		
Hook height double reeving [m]		44.3	67.3		
Wind category		C25			

## 3 Tower combinations

### 3.6 Tower combinations on mobile cross frame (slewing section with TFS 15 - connection)

Jib length		25 m – 50 m			
Item					
1	4.5 m	TFS 15	TFS 15	TFS 15	
2	9.0 m	TFS 15	TFS 15	TFS 15	
3	13.5 m	TFS 15	TFS 15	TFS 15	
4	18.0 m	TFS 15	TFS 15	TFS 15	
5	22.5 m	TFS 15.4	TFS 15.4	TFS 15.4	
6	27.0 m	TFS 15.4	TFS 15.4	TFS 15.4	
7	31.5 m	TFS 15.4	TFS 15.4	TFS 15.4	
8	36.0 m	TFS 15.4	UVA 15.4	UVA 15.4	
9	40.5 m	UVA 15.4	UV 15.4	UV 15.4	
10	45.0 m	UV 15.4	UVÜ 15.4	UVÜ 15.4	
11	49.5 m	UVÜ 15.4	UV 20.4	UV 20.4	
12	54.0 m	UV 20.4	UV 20.4	UV 20.4	
13	58.5 m	UV 20.4	TVA 20.4	TVA 20.4	
14	63.0 m		TV 20.4	TV 20.4	
15	67.5 m		TV 20.4	TV 20.4	
16	72.0 m		TV 20.4	TV 20.4	
17	76.5 m		TV 20.4	TV 20.4	
Substructure		KRF 10-46/60	KRF4 12-60/80	KRF6 12-60/80	
Corner distance [m x m]		6.0 x 6.0	8.0 x 8.0	8.0 x 8.0	
Substructure height [m]		2.0	2.5	2.9	
Tower height [m]		60.5	79.0	79.4	
Hook height double reeving [m]		63.5	82.0	82.4	
Wind category		C25			

Jib length	25 m – 50 m				
Item					
1	4.5 m	TFS 15			
2	9.0 m	TFS 15			
3	13.5 m	TFS 15			
4	18.0 m	TFS 15			
5	22.5 m	TFS 15.4			
6	27.0 m	TFS 15.4			
7	31.5 m	TFS 15.4			
8	36.0 m	UVA 15.4			
9	40.5 m	UV 15.4			
10	45.0 m	UVÜ 15.4			
11	49.5 m	UV 20.4			
12	54.0 m	TVA 20.4			
13	58.5 m	TV 20.4			
14	63.0 m	TV 20.4			
15	67.5 m	TV 20.4			
16	72.0 m	TV 20.4			
17	73.0 m	VR 2023			
18	77.5 m	TV 23			
19	82.0 m	HTA 23			
20	86.5 m	HT 23			
Substructure	KRF6 12-60/80				
Corner distance [m x m]	8.0 x 8.0				
Substructure height [m]	2.9				
Tower height [m]	89.4				
Hook height double reeving [m]	92.4				
Wind category	C25				

## 3 Tower combinations



### 3.7 Tower combinations on undercarriage (slewing section with TFS 15 - connection)

Jib length		25 m – 50 m			
Item					
1	4.5 m	TFS 15	TFS 15	TFS 15	TFS 15
2	9.0 m	TFS 15	TFS 15	TFS 15	TFS 15
3	13.5 m	TFS 15	TFS 15	TFS 15	TFS 15
4	18.0 m	TFS 15	TFS 15	TFS 15	TFS 15
5	22.5 m	TFS 15	TFS 15	TFS 15	TFS 15
6	27.0 m	UVA 15.4	TFS 15.4	TFS 15.4	TFS 15.4
7	31.5 m		UVA 15.4	UVA 15.4	TFS 15.4
8	36.0 m			UVÜ 15.4	UVA 15.4
9	40.5 m				UVÜ 15.4
Substructure		UW 250	UW 250	UW 260.1	UW 260.1
Corner distance [m x m]		4.5 x 5.44	5.0 x 5.0	5.0 x 6.79	6.0 x 6.0
Substructure height [m]		4.5	4.5	4.5	4.5
Tower height [m]		31.5	36.0	40.5	45.0
Hook height double reeving [m]		34.5	39.0	43.5	48.0
Wind category		C25			

Jib length	25 m – 50 m				
Item					
1	4.5 m	TFS 15	TFS 15	TFS 15	TFS 15
2	9.0 m	TFS 15	TFS 15	TFS 15	TFS 15
3	13.5 m	TFS 15	TFS 15	TFS 15	TFS 15
4	18.0 m	TFS 15	TFS 15	TFS 15	TFS 15
5	22.5 m	TFS 15	TFS 15	TFS 15	TFS 15.4
6	27.0 m	TFS 15.4	TFS 15.4	TFS 15.4	TFS 15.4
7	31.5 m	UVA 15.4	TFS 15.4	TFS 15.4	TFS 15.4
8	36.0 m	UVÜ 15.4	UVA 15.4	UVA 15.4	TFS 15.4
9	40.5 m	TVA 20.4	UVÜ 15.4	UVÜ 15.4	UVA 15.4
10	45.0 m		TVA 20.4	TVA 20.4	UVÜ 15.4
11	49.5 m				UV 20.4
12	54.0 m				TVA 20.4
Substructure		UW 260.2	UW 260.2	UW 260.3	UW 260.3
Corner distance [m x m]		5.0 x 6.79	6.0 x 6.0	5.0 x 6.79	6.0 x 6.0
Substructure height [m]		4.5	4.5	4.5	4.5
Tower height [m]		45.0	49.5	49.5	58.5
Hook height double reeving [m]		48.0	52.5	52.5	61.5
Wind category		C25			

4 Foundation loads / central ballast weights / corner loads in compliance with EN 14439 / EN 13001

## 4 Foundation loads / central ballast weights / corner loads in compliance with EN 14439 / EN 13001

	<p><b>⚠ DANGER</b></p> <p>Usage of incorrect tower combinations. The slewing tower crane may overturn.</p> <ol style="list-style-type: none"> <li>1) Use the specified tower combinations.</li> <li>2) If you need another tower combination that is not specified here, please contact WOLFFKRAN to get an approved alternative setup in writing.</li> </ol>
	<p><b>NOTICE</b></p> <p>If you need foundation loads for tower combination with tower element TV 25 and UV 25, please contact WOLFFKRAN to get an approved alternative setup.</p>

### Jib positions

The corner loads are given for two jib positions with the maximum corner load resulting from jib position 1.

For square setup, the following equation is true:  $a = b$

For rectangular setup, the following equation is true:  $a > b$

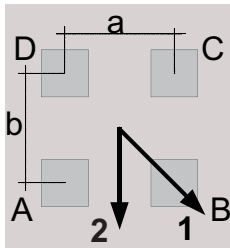

Cross frame or cross frame element

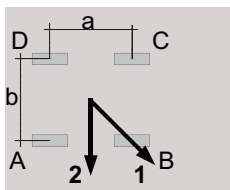

Undercarriage

**NOTICE!** For undercarriage details, please refer to the relevant operating manual.

### Wind load with crane out of operation

The stability for stormy weather is calculated on the basis of wind region C (EN 13001-2). The reference wind speed for zone C is 28 m/s (10 m above ground, averaged over 10 minutes). As a basis, a recurrence interval of 25 years is used. As a basis, a recurrence interval of 25 years is used.

Please contact WOLFFKRAN for stability calculations in other wind regions.



4 Foundation loads / central ballast weights / corner loads in compliance with EN 14439 / EN 13001

For information on the different substructures, refer to Section 5 of the Operating Manual.

## 4.1 Foundation loads jib 25 m - 50 m

Slewing section 5014 city with 25 m - 50 m jib on foundation anchor.

### Foundation load in compliance with EN 14439 / EN 13001 – typical loads

Includes all dynamical factors under consideration of second-order theory for stationary slewing tower cranes on concrete foundation in compliance with a tower combination without climbing frame.

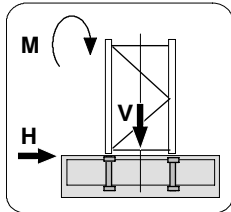



HH	Crane in service			Crane out of service			Assembly		
2	Slewing torque: 110 kNm			Wind category C25					
STR	M	V	H	M	V	H	M	V	H
[m]	[kNm]	[kN]	[kN]	[kNm]	[kN]	[kN]	[kNm]	[kN]	[kN]
7.5	830	309	13	830	261	27	1100	151	5
12.0	900	322	14	960	274	31	1120	164	6
16.5	970	335	15	1120	287	35	1150	177	7
21.0	1050	348	16	1290	300	39	1190	190	7
25.5	1140	361	17	1490	314	43	1230	203	8
30.0	1240	374	19	1720	327	47	1280	216	9
34.5	1350	387	20	1970	340	51	1340	229	9
39.0	1480	400	21	2250	353	55	1400	243	10
43.5	1630	414	22	2570	366	59	1470	256	11
48.0	1760	435	24	3040	439	87	1530	277	12
52.5	1930	452	25	3640	456	93	1610	295	12
57.0	2070	473	27	4220	477	102	1680	315	13
61.5	2250	513	30	4900	495	110	1760	333	14
66.0	2380	557	33	5540	539	121	1820	377	16
70.5	2570	585	35	6330	567	131	1910	405	17
75.0	2780	613	37	7200	595	141	2010	433	18
79.5	3010	642	38	8150	624	150	2110	462	19
80.5	3040	669	40	8320	651	155	2130	489	20
85.0	3280	699	42	9350	681	165	2240	519	21
89.5	3500	763	45	10440	745	179	2350	583	22
94.0	3760	802	47	11620	784	191	2480	623	24
98.5	4050	842	49	12910	824	202	2610	662	25
100.8	4140	893	51	13530	875	212	2670	713	26
105.3	4450	932	53	14980	914	224	2820	752	27

**Caption:**

HH	Hook height	V:	Vertical load
H:	Horizontal load	M:	Torque
STR:	Number of falls		

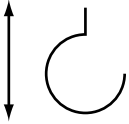
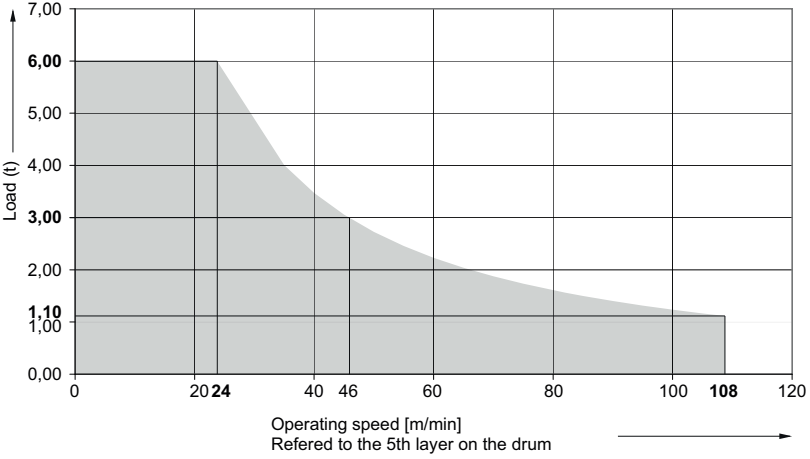
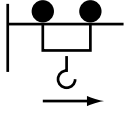
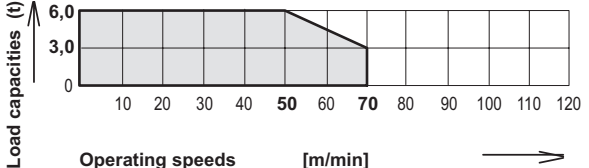

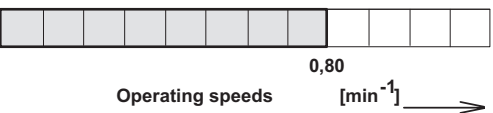









## 5 Operating speeds

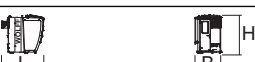

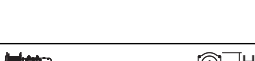

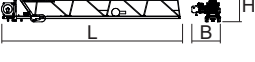
Drive unit [type]	Operating speed Carrying load		Hook travel distance max. [m]	Power [kW]	Total connected load [kVA]
Hw628.1FU	Lifting / lowering		190	28	34 Total connected load at coincidence factor of 0.7
	 <p>Operating speed [m/min] Referred to the 5th layer on the drum</p>				
<b>KW</b>	<b>Trolley movement</b>			<b>4.0</b>	
	 <p>Operating speeds [m/min]</p>				
<b>SG</b>	<b>Slewing</b>			<b>4.0</b>	
	 <p>Operating speeds [min<sup>-1</sup>]</p>				

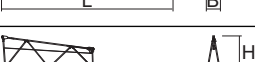
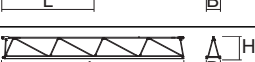
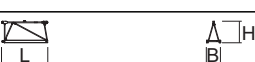
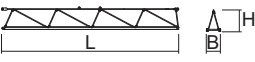
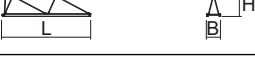
## 6 Package list

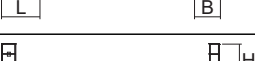
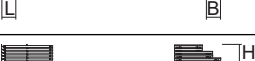
## 6 Package list

### 6.1 Package list 5014

Pcs.	Description	Package	L [m]	W [m]	H [m]	Weight [kg]	Volume [m <sup>3</sup> ]
1	Tower head section, complete		5.38	1.92	1.76	4105	18.18
1	Connection tower element		1.98	1.02	1.41	810	2.85
1	Tower head section lower part		4.53	1.92	1.76	3295	15.31
1	Driver's cab station platform incl. control cabinet		3.12	1.77	1.91	1025	10.55
1	Driver's cab (option, alternative: wireless remote control)		2.16	1.46	2.34	940	7.38
1	Counterjib (inkl. jib stay parts and platforms)		10.17	1.60	0.52	2425	8.46
1	Hoisting gear Hw 628.1FU (incl. 465 m hoisting rope) (optional 2nd brake)		1.86	0.84	0.82	1605 (320)	1.28
1	Jib element 1 (incl. trolley drive and hoisting gear with 465 m hoisting rope)		12.04	1.88	2.17	4265	49.12
1	Jib section 2		10.19	0.82	2.00	990	16.71
1	Jib section 3		5.47	0.82	1.95	435	8.75
1	Jib section 4		10.18	0.82	1.30	695	10.85
1	Jib section 5		2.66	0.82	1.30	200	2.84
1	Jib section 6		10.16	0.82	1.30	605	10.83
1	Jib section 7		5.15	0.82	1.30	270	5.49
1	Rope swivel crossbeam		0.79	0.75	0.43	60	0.25
1	Trolley LK 6		1.57	1.07	0.92	185	1.55
1	Maintenance cage		0.75	0.50	2.05	55	0.77
32	Standard railings		1.10	2.55	1.05	332	2.95

Pcs.	Description	Package	L [m]	W [m]	H [m]	Weight [kg]	Volume [m <sup>3</sup> ]
1	Snatch block U 6	 	0.40	0.34	0.87	225	0.12
7	Counterweight block	 	1.60	0.23	2.38	1800	0.88

Bracketed weights must be added to their associated components.

7 Assembly weights

7 Assembly weights

7.1 Counterweight blocks

	<b>NOTICE</b>
	The described diagrams of the counterweights and central ballast blocks only show sketches. Have them issue the reinforcement charts by experts.

## 7.1.1 Counterweight block, 1.8 t

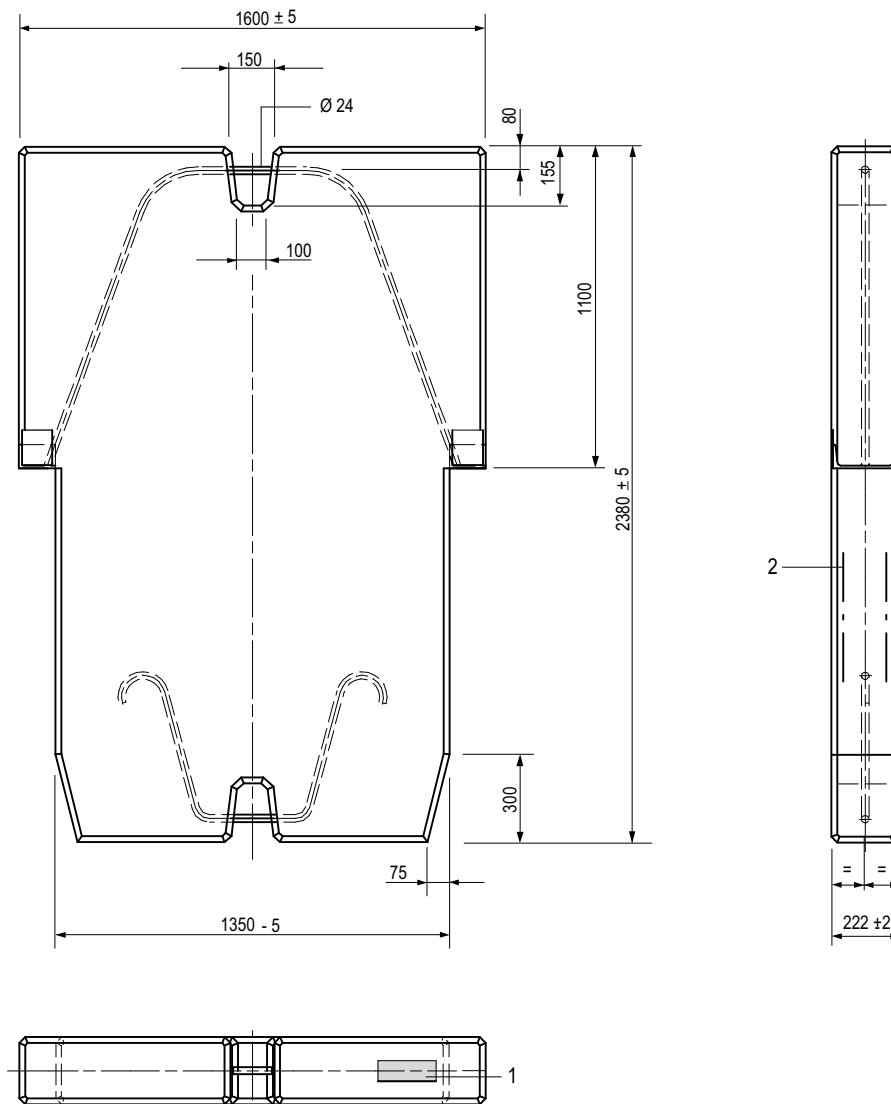

Data counterweight block 1.8 t

Item	Data
Material	Concrete, min. C 20/25
Max. permitted weight tolerance	+/- 3 %
Order number	30042420 / 962-2-028365
1	Component identifier
2	Construction steel reinforcement

## 7 Assembly weights

### 7.2 Total weight jib assembly

Trolley jib complete: including platforms and handrails, hoisting gear, trolley drive, trolley, snatch block, ropes, brace plates, assembly brackets and brackets for jib transport.

Jib length [m]	Weight [kg] WOLFF 5014 city
50.0	7580
47.5	7510
45.0	7310
42.5	7175
40.0	6975
37.5	6905
35.0	6705
32.5	6485
30.0	6285
27.5	6215
25.0	6015

Trolley jib complete: including counterjib, platforms and handrails, hoisting gear, trolley drive, trolley, snatch block, ropes, brace plates, assembly brackets and brackets for jib transport.

Jib length [m]	Weight [kg] WOLFF 5014 city
50.0	10211
47.5	10141
45.0	9941
42.5	9806
40.0	9606
37.5	9536
35.0	9336
32.5	9116
30.0	8916
27.5	8846
25.0	8646



## 7.3 Assembly weight slewing gear

without driver's cab

Module	Crane parts	Weight [kg]
Tower top complete with control cabinet platform		5200
Tower head section, complete		4135
	▪ Connection tower element	810
	▪ Slewing frame	1519
	▪ Tower head section lower part (Sput)	1775
	▪ Platforms, standard railings and standard posts	31
Control cabinet platform complete		1065
	▪ Platform	520
	▪ Control cabinet	350
	▪ Resistor	48
	▪ Platform insert	40
	▪ standard railings and standard posts	42
	▪ Signal lamps and small items	65

With driver's cab (option)

Module	Crane parts	Weight [kg]
Tower top complete with control cabinet platform and driver's cab		6090
Tower head section, complete		4135
	▪ Connection tower element	810
	▪ Slewing frame	1519
	▪ Tower head section lower part (Sput)	1775
	▪ Platforms, standard railings and standard posts	31
Control cabinet platform complete		1015
	▪ Platform	520
	▪ Control cabinet	350
	▪ Resistor	48
	▪ standard railings and standard posts	32
	▪ Signal lamps and small items	65
Driver's cab		940

## 7 Assembly weights

### 7.4 Assembly weight cross frame

Module	crane part	Weight [kg]	
Cross frame KR 6-40 (without accessories)			
(4.0 m x 4.0 m)	▪ 4 bolted spigots AZ 93.4 E 15	240	3450
	▪ 4 bolted spigots AZ 120M	315	
Cross frame KR 7-32 (without accessories)			
(3.2 m x 3.2 m)	▪ 4 bolted spigots AZ 85 E 20.5	230	3350
	▪ 4 bolted spigots AZ 93.4 E 15	240	
	▪ 4 bolted spigots AZ 120 M	315	
Cross frame KRV 7-32 (without accessories)			
(3.2 m x 3.2 m)	▪ 4 bolted spigots AZ 85 E 20.5	230	3680
	▪ 4 bolted spigots AZ 93.4 E 15	240	
	▪ 4 bolted spigots AZ 120 M	315	
Cross frame KRV 7-32/46 (without accessories)			
(4.6 m x 4.6 m)	▪ 4 bolted spigots AZ 85 E 20.5	230	5090
	▪ 4 bolted spigots AZ 93.4 E 15	240	
	▪ 4 bolted spigots AZ 120 M	315	
Cross frame KR 8-46 (without accessories)			
(4.6 m x 4.6 m)	▪ 4 bolted spigots AZ 85 E 20.5	230	5250
	▪ 4 bolted spigots AZ 93.4 E 15	240	
	▪ 4 bolted spigots AZ 120 M	315	
Cross frame KR 10-46 (without accessories)			
(4.6 m x 4.6 m)	▪ 4 bolted spigots AZR 120 E 15,5	552	7020
	▪ 4 bolted spigots AZ 140 M	698	
Cross frame KR 16 - 46/ 60 (without accessories)			
(6.0 m x 6.0 m)	▪ 4 bolted spigots AZR 120 E 15,5	552	8875
	▪ 4 bolted spigots AZ 140 M	698	
Cross frame KRV 10-60 (without accessories)			
(6.0 m x 6.0 m)	▪ 4 bolted spigots AZ 120 E 15,5 KRV 10-60	730	9990
	▪ 4 bolted spigots AZ 140 M KRV 10-60	790	
	▪ 4 bolted spigots AZ 140 E 10 KRV 10-60	790	
	▪ 4 bolted spigots AZ 140 M KRV 10-60	715	

Module	crane part	Weight [kg]	
Cross frame KR 12-60 (without accessories)			
(6.0 m x 6.0 m)	▪ 4 bolted spigots AZ 120 E 15,5 KR 12-60	730	15650
	▪ 4 bolted spigots AZ 140 M KR 12-60	790	
	▪ 4 bolted spigots AZ 140 E10 KR 12-60	790	
	▪ 4 bolted spigots AZ 156 M KR 12-60	845	
	▪ 4 bolted spigots AZ 140 E17 KR 12-60	875	
	▪ 4 bolted spigots AZ 160 M KR 12-60	905	
Cross frame KR 12-60/ 80 (without accessories)			
(8.0 m x 8.0 m)	▪ 4 bolted spigots AZ 120 E 15,5 KR 12-60	730	19260
	▪ 4 bolted spigots AZ 140 M KR 12-60	790	
	▪ 4 bolted spigots AZ 140 E10 KR 12-60	790	
	▪ 4 bolted spigots AZ 156 M KR 12-60	845	
	▪ 4 bolted spigots AZ 140 E17 KR 12-60	875	
	▪ 4 bolted spigots AZ 160 M KR 12-60	905	
Cross frame KR HEB 700- 4 (without accessories)			
(4.0 m x 4.0 m)	▪ 4 bolted spigots AZ 93.4 M	240	4450
Cross frame KR HEB 700 - 5 (without accessories)			
(5.0 m x 5.0 m)	▪ 4 bolted spigots AZ 93.4 M	240	5410
Cross frame KR HEB 800- 5 (without accessories)			
(5.0 m x 5.0 m)	▪ 4 bolted spigots AZ 120 M	292	5860
Cross frame KR HEB 800- 6 (without accessories)			
(6.0 m x 6.0 m)	▪ 4 bolted spigots AZ 120 M	292	6600

## 7 Assembly weights

### 7.5 Assembly weight supporting frame

Module	crane part	Weight [kg]	
Supporting frame SR 150 (without accessories) (4.6 m x 4.6 m)			5460
	▪ 4 bolted spigots AZ 85 E 20.5	210	
	▪ 4 bolted spigots AZ 93.4 E 15	240	
	▪ 4 bolted spigots AZ 120 M	292	

## 7.6 Assembly weight cross frame elements

Module	Crane parts	Weight [kg]	
Cross frame element KRE 250 complete			5750
	▪ Cross frame platform with hinged section, corner plates and transport locks	2730	
	▪ Mast base with diagonal struts and tie rods	3020	
Cross frame element KRE 260.1, complete			8100
	▪ Cross frame platform with hinged section, corner plates and transport locks	4320	
	▪ Mast base with diagonal struts and tie rods	3780	
Cross frame element KRE 260.2, complete			10900
	▪ Cross frame platform with hinged section, corner plates and transport locks	5455	
	▪ Mast base with diagonal struts and tie rods	5445	

## 7 Assembly weights

### 7.7 Assembly weight undercarriage

Module	Crane parts	Weight [kg]	
Undercarriage UW 250, complete			8800
	▪ Undercarriage platform with hinged sections, subframes and transport locks	5600	
	▪ Mast base with diagonal struts and tie rods	3200	
Undercarriage UW 260.1, complete			11400
	▪ Undercarriage platform with hinged sections, subframes and transport locks	7150	
	▪ Mast base with diagonal struts and tie rods	4250	
Undercarriage UW 260.2, complete			14060
	▪ Undercarriage platform with hinged sections, subframes and transport locks	9810	
	▪ Mast base with diagonal struts and tie rods	4250	
Undercarriage UW 260.3, complete			17200
	▪ Undercarriage platform with hinged sections, subframes and transport locks	11300	
	▪ Mast base with diagonal struts and tie rods	5900	

## 7.8 Assembly weights travelling cross frame

Module	Crane parts	Weight [kg]	
Mobile cross frame KRF 10 – 46/60 complete (6.0 m x 6.0 m)			17500
	▪ Cross frame	7000	
	▪ Drive gear corners	2385	
	▪ Backing braces	1510	
	▪ Subframe	5645	
	▪ Platforms + ladders	510	
	▪ Control cabinet	130	
	▪ small items	320	
	▪ Set of bolted spigots AZR 120 E 15,5	552	
	▪ Set of bolted spigots AZ 140 M	698	
Mobile cross frame KRF4 12-60/80 complete (8.0 m x 8.0 m)			32300
	▪ Cross frame	14170	
	▪ Backing braces	2875	
	▪ Drive gear corners	4560	
	▪ Subframe	9380	
	▪ Platforms and ladders	255	
	▪ Control cabinet	130	
	▪ small items	930	
	▪ 4 bolted spigots AZ 120 E 15,5 KR 12-60	730	
	▪ 4 bolted spigots AZ 140 M KR 12-60	790	
	▪ 4 bolted spigots AZ 140 E10 KR 12-60	790	
	▪ 4 bolted spigots AZ 156 M KR 12-60	845	
	▪ 4 bolted spigots AZ 140 E17 KR 12-60	875	
	▪ 4 bolted spigots AZ 160 M KR 12-60	905	

## 7 Assembly weights

Module	Crane parts	Weight [kg]	
Mobile cross frame (8.0 m x 8.0 m)	KRF6 12-60/80 complete		41200
	▪ Cross frame	14170	
	▪ Backing braces	2875	
	▪ Drive gear corners	4560	
	▪ Subframe	18270	
	▪ Platforms and ladders	255	
	▪ Control cabinet	130	
	▪ small items	940	
	▪ 4 bolted spigots AZ 120 E 15,5 KR 12-60	730	
	▪ 4 bolted spigots AZ 140 M KR 12-60	790	
	▪ 4 bolted spigots AZ 140 E10 KR 12-60	790	
	▪ 4 bolted spigots AZ 156 M KR 12-60	845	
	▪ 4 bolted spigots AZ 140 E17 KR 12-60	875	
	▪ 4 bolted spigots AZ 160 M KR 12-60	905	



## 7.9 Assembly weights city portal

Module	Crane parts	Weight [kg]	
City portal CP 380 (3.8 m x 3.8 m)			10700
	▪ Cross frame (without accessories)	3680	
	▪ City Portal undercarriage	7020	
	▪ small items	160	
	▪ 4 bolted spigots AZ 85 E 20.5	230	
	▪ 4 bolted spigots AZ 93.4 E15	240	
	▪ 4 bolted spigots AZ 120 M	315	
City portal CP 520, complete (without bolted spigots) (5.24 m x 5.24 m)			13335
	▪ Cross frame (without accessories)	7000	
	▪ City Portal undercarriage	6335	
	▪ small items	425	
	▪ 4 bolted spigots AZ 120 E 15.5	560	
	▪ 4 bolted spigots AZ 140 M	684	

## 7 Assembly weights

### 7.10 Hook height above ground required for mobile cranes

For information about the height of the WOLFF slewing tower crane, refer to Tower combinations [8].

**NOTICE! During assembly, allowances must be made for level differences (mobile crane to base of the slewing tower crane).**

Hook height above ground required for mobile cranes (X) = height of the WOLFF slewing tower crane (A) + clearance of 13 (B).

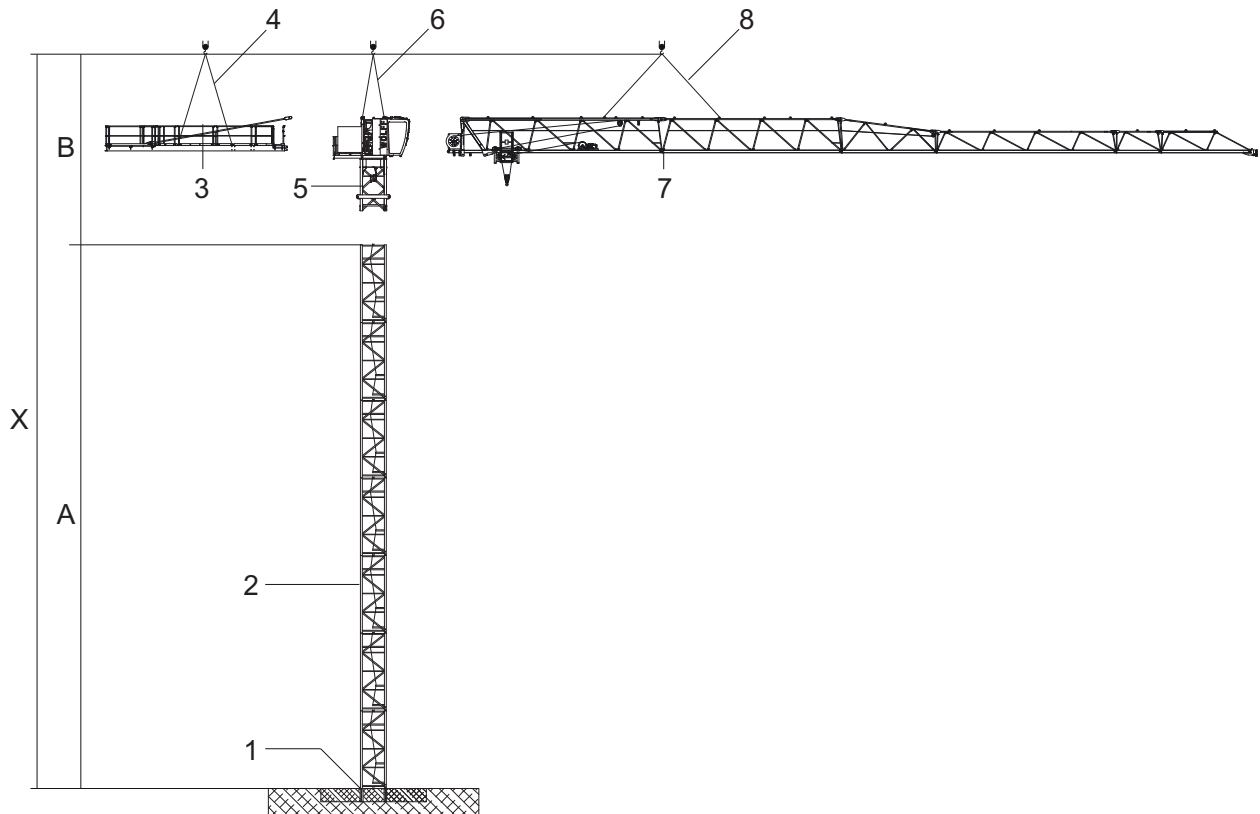

Exemplary illustration

[A]	Height of the WOLFF slewing tower crane	[B]	Clearance 13 m
[X]	Hook height above ground required for the mobile crane		
1	Substructure f. e.: ▪ Foundation anchors	5	Tower head section, complete
2	Tower element	6	Four-point lifting tackle (4 m with shackle)
3	Counterjib	7	Trolley jib
4	Four-point lifting tackle (4 m with shackle)	8	Two-point lifting tackle (4 m with shackle)

**(see also):**

- Tower combinations [8]

## 8 Assembly diagrams

### 8.1 Jib attachment diagram

	<b>NOTICE</b>
	For jib assembly, use a Two-point lifting tackle (4 m with shackle).

#### Length of jib elements

Item	Length [m]
Jib element 1	11.81
Jib element 2, 4, 6	10.0
Jib section 3	5.28
Jib section 7	5.0
Jib section 5	2.5

## 8 Assembly diagrams

### 8.1.1 Divided jib assembly

In case of divided jib assembly for all jib lengths shall apply:

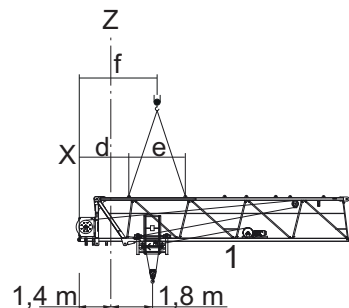

1	Jib element 1	f	Dimension f
d	Dimension d	X	Pivot point counterjib
e	Dimension e	Z	Middle of tower

	All jib lengths
Data	Jib element 1
d [m]	2.13
e [m]	2.50
f [m]	3.38
Weight [kg]	4530

### 8.1.1.1 Trolley jib - attachment diagram 50.0 m to 45.0 m

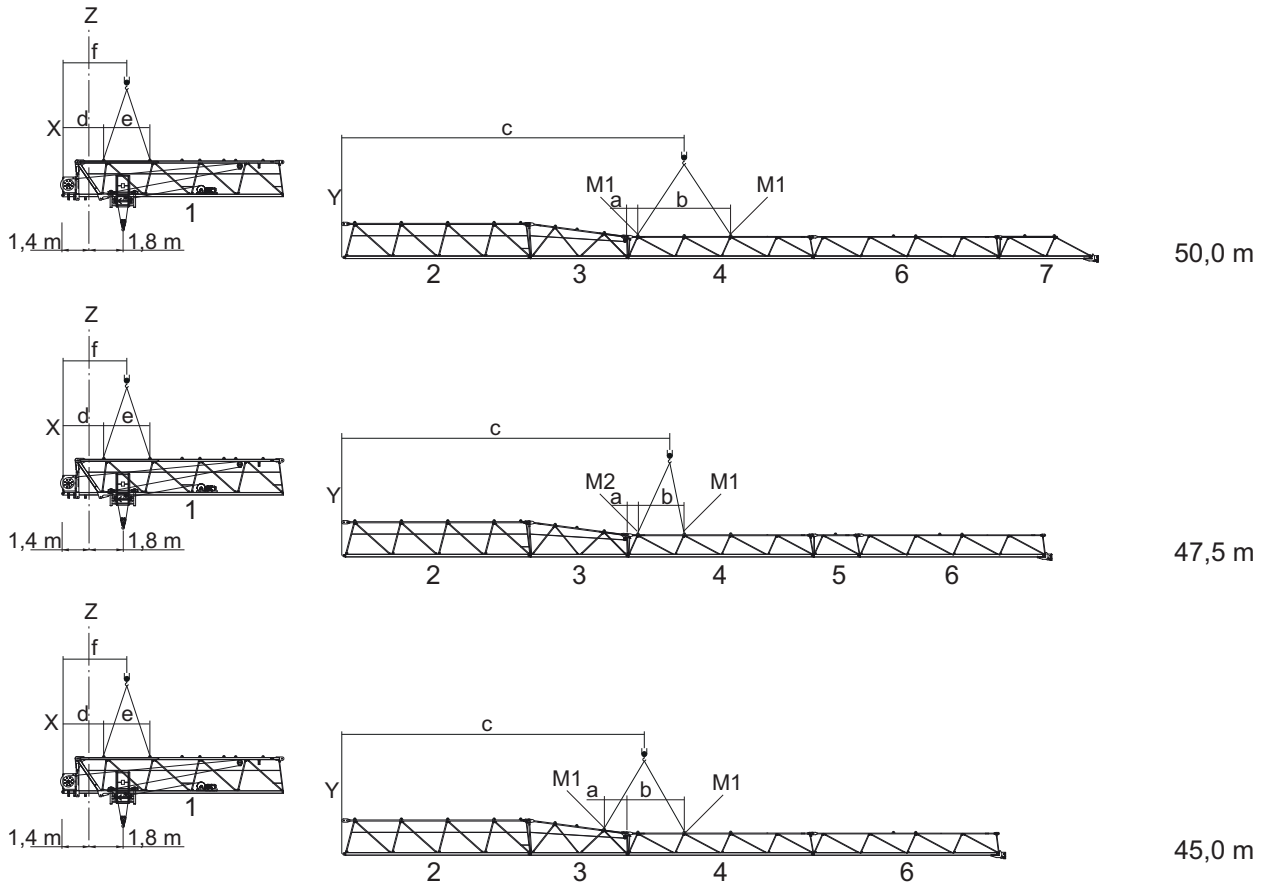

a	Dimension a	X	Pivot point counterjib
b	Dimension b	Y	Front edge of jib element 2
c	Dimension c	Z	Middle of tower
d	Dimension d	M1	Assembly bracket type 1
e	Dimension e	M2	Assembly bracket type 2
f	Dimension f		

Data	Jib length [m]		
	50.0	47.5	45.0
a [m]	0.57	0.57	1.25
b [m]	5.00	2.50	3.07
c [m]	18.35	17.53	16.19
Weight [kg] without jib element 1	3050	2980	2780

## 8 Assembly diagrams

### 8.1.1.2 Trolley jib - attachment diagram 42.5 m to 37.5 m

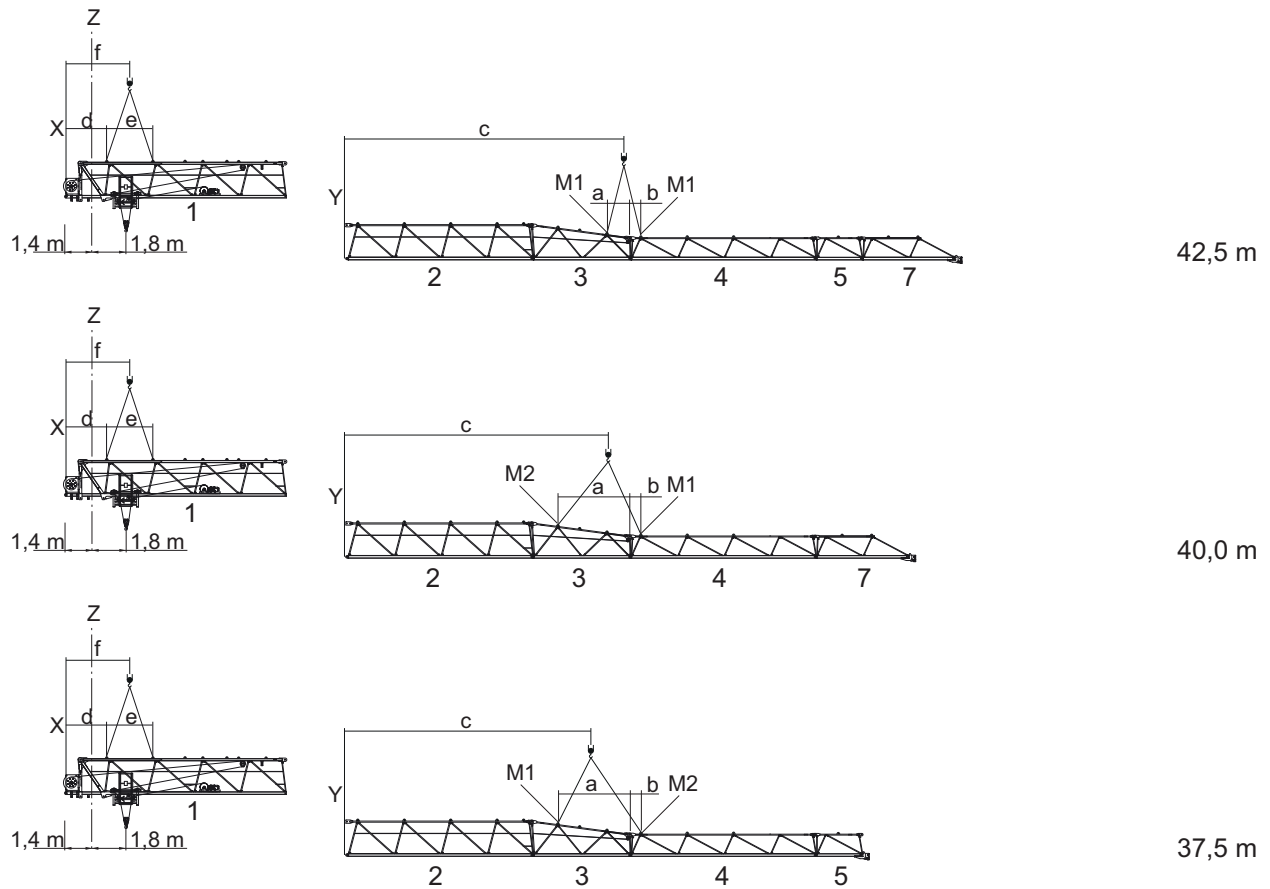

a	Dimension a	f	Dimension f
b	Dimension b	Y	Front edge of jib element 2
c	Dimension c	M1	Assembly bracket type 1
d	Dimension d	M2	Assembly bracket type 2
e	Dimension e		

Data	Jib length [m]		
	42.5	40.0	37.5
a [m]	1.25	3.89	3.89
b [m]	0.57	0.57	0.57
c [m]	14.94	13.86	13.38
Weight [kg] without jib element 1	2645	2445	2375

### 8.1.1.3 Trolley jib - attachment diagram 35.0 m to 30.0 m

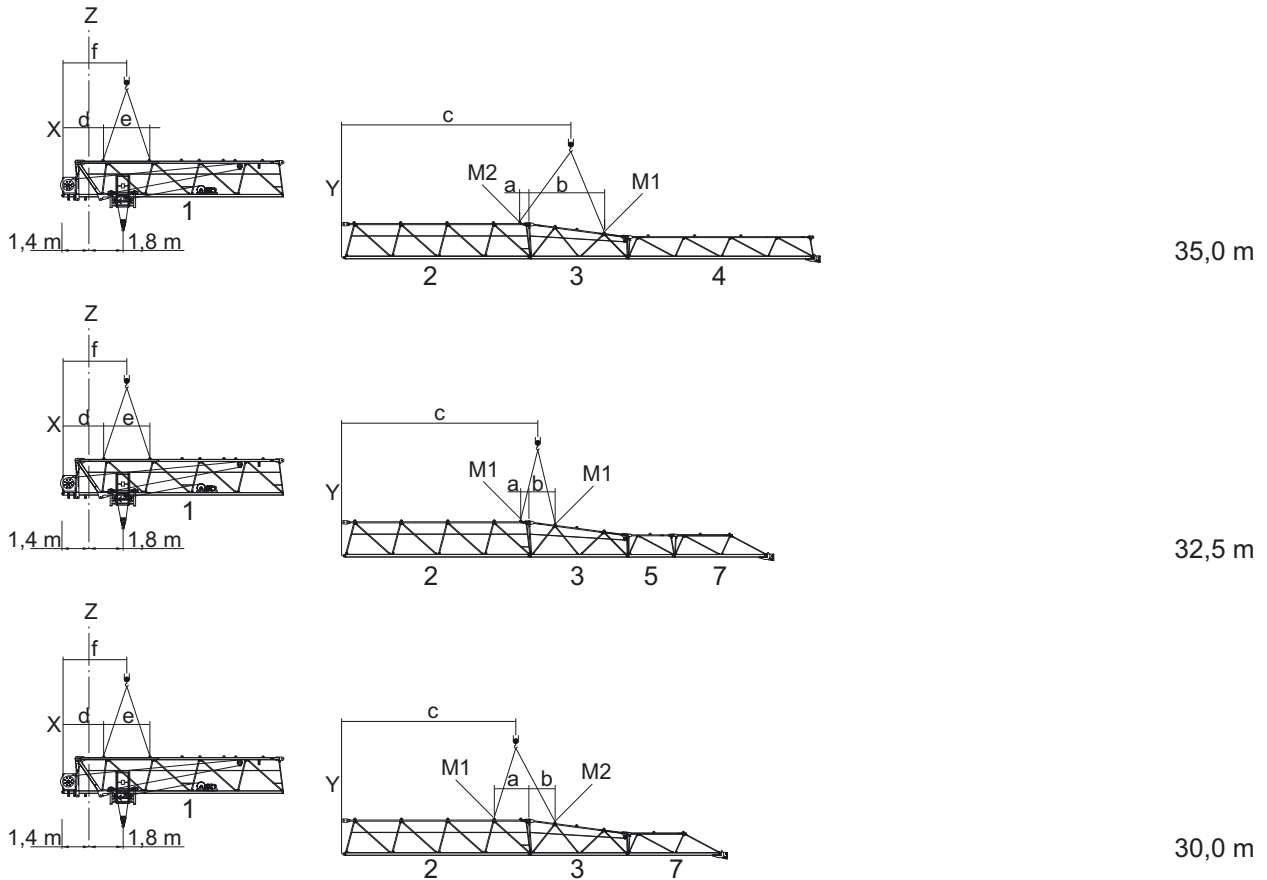

a	Dimension a	f	Dimension f
b	Dimension b	Y	Front edge of jib element 2
c	Dimension c	M1	Assembly bracket type 1
d	Dimension d	M2	Assembly bracket type 2
e	Dimension e		

Data	Jib length [m]		
	35.0	32.5	30.0
a [m]	0.43	0.43	1.93
b [m]	4.03	1.39	1.39
c [m]	12.04	10.48	9.41
Weight [kg] without jib element 1	2175	1955	1755

## 8 Assembly diagrams

### 8.1.1.4 Trolley jib - attachment diagram 27.5 m to 25.0 m

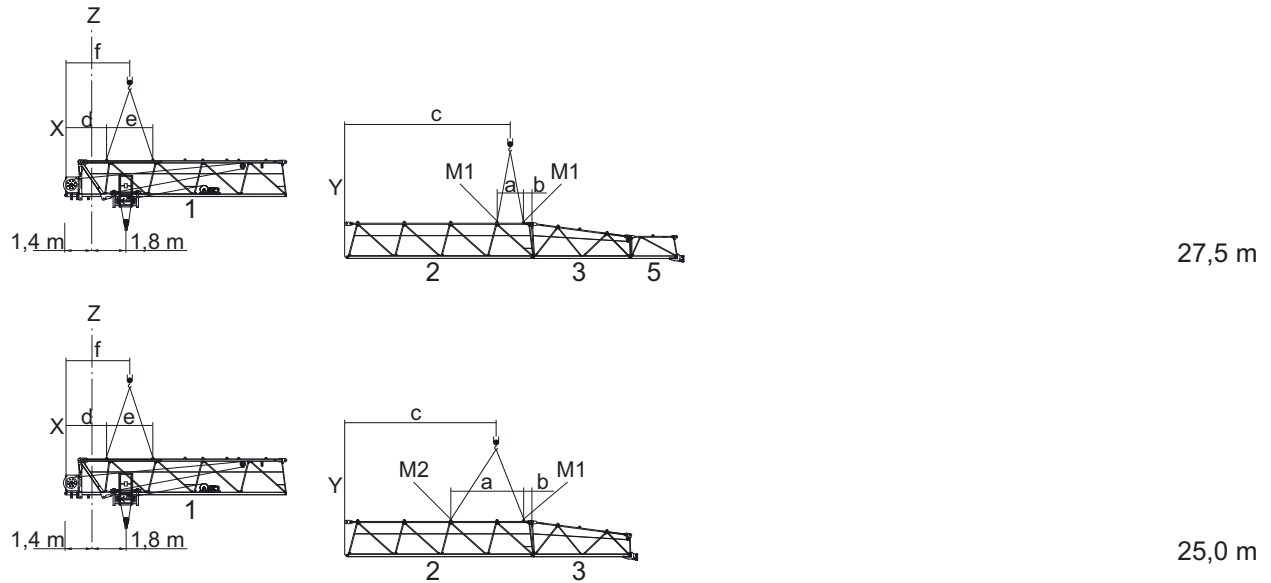

a	Dimension a	f	Dimension f
b	Dimension b	Y	Front edge of jib element 2
c	Dimension c	M1	Assembly bracket type 1
d	Dimension d	M2	Assembly bracket type 2
e	Dimension e		

Data	Jib length [m]	
	27.5	25.0
a [m]	1.50	4.00
b [m]	0.43	0.43
c [m]	8.82	7.84
Weight [kg] without jib element 1	1685	1485



## 8.1.2 Assembly of the entire jib without counterjib

### 8.1.2.1 Trolley jib - attachment diagram 50.0 m to 45.0 m

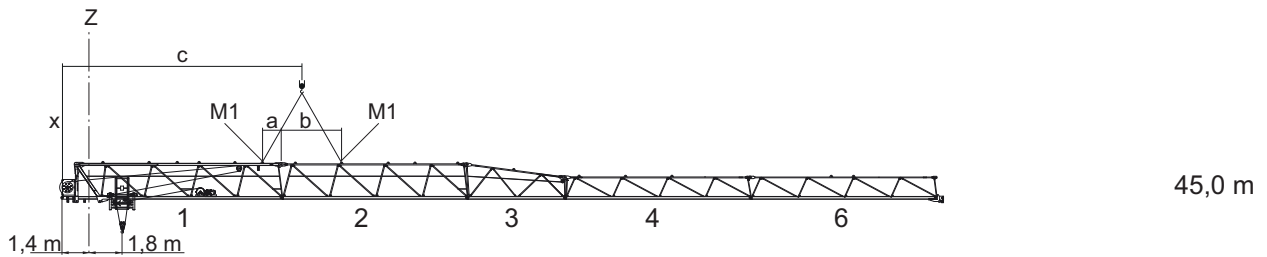
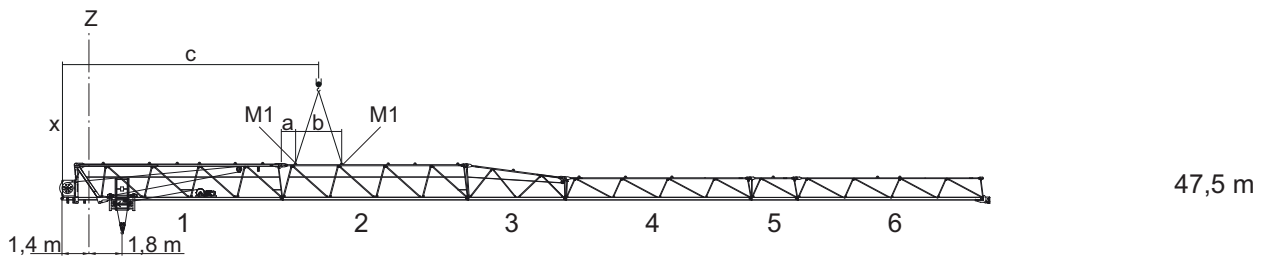
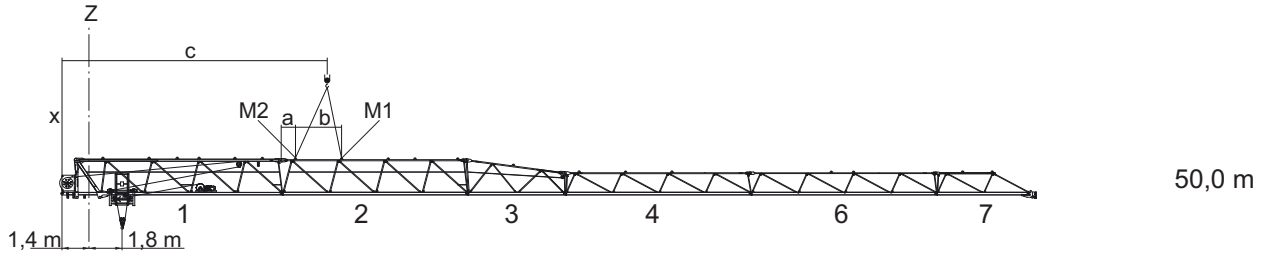

a	Dimension a	Z	Middle of tower
b	Dimension b	M1	Assembly bracket type 1
c	Dimension c	M2	Assembly bracket type 2
X	Pivot point counterjib		

Data	Jib length [m]		
	50.0	47.5	45.0
a [m]	0.57	0.57	1.03
b [m]	2.50	2.50	3.07
c [m]	14.06	13.63	12.83
Weight [kg]	7580	7510	7310

## 8 Assembly diagrams

### 8.1.2.2 Trolley jib - attachment diagram 42.5 m to 37.5 m

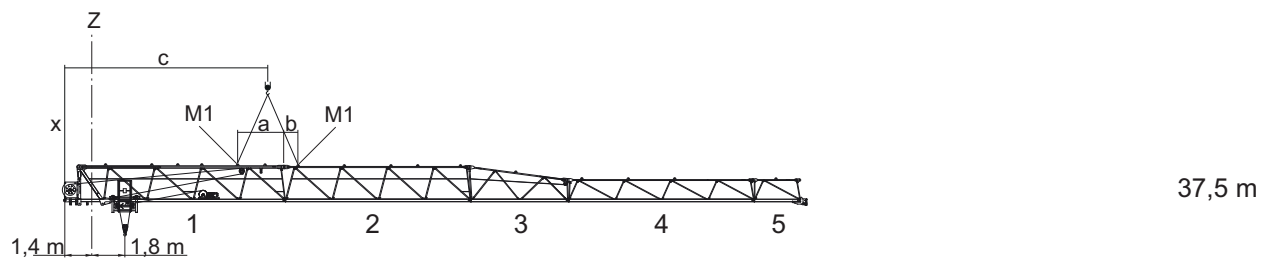
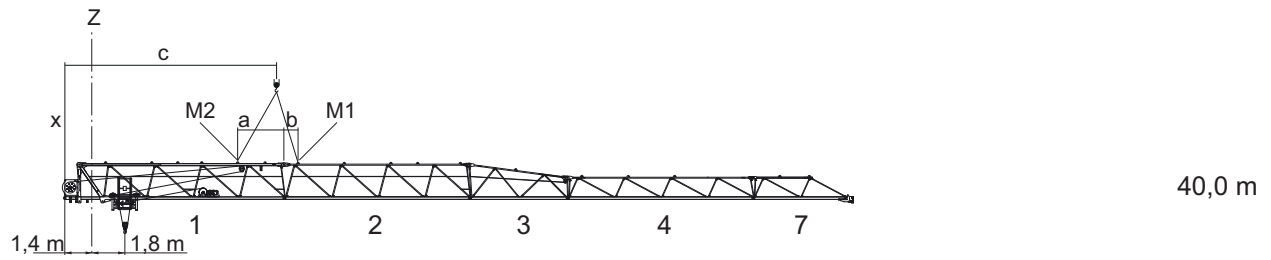
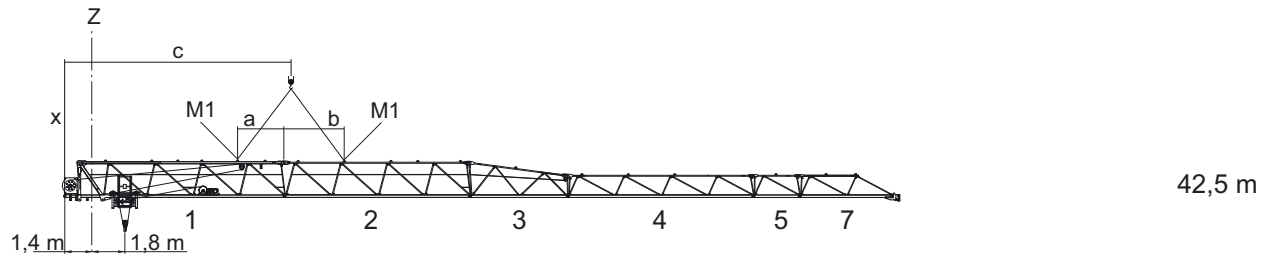

a	Dimension a	Z	Middle of tower
b	Dimension b	M1	Assembly bracket type 1
c	Dimension c	M2	Assembly bracket type 2
X	Pivot point counterjib		

Data	Jib length [m]		
	42.5	40.0	37.5
a [m]	2.58	2.58	2.58
b [m]	3.07	0.57	0.57
c [m]	12.06	11.15	10.81
Weight [kg]	7175	6975	6905

### 8.1.2.3 Trolley jib - attachment diagram 35.0 m to 30.0 m

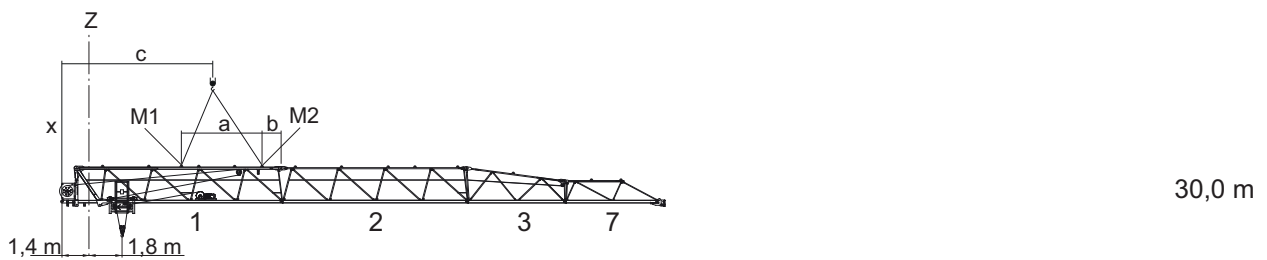
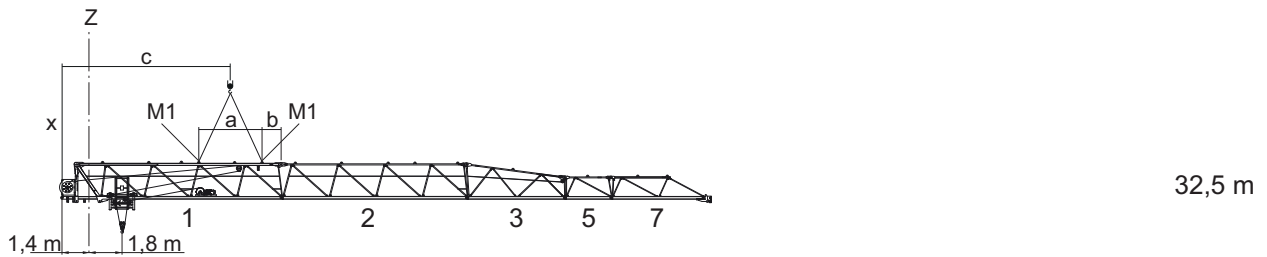
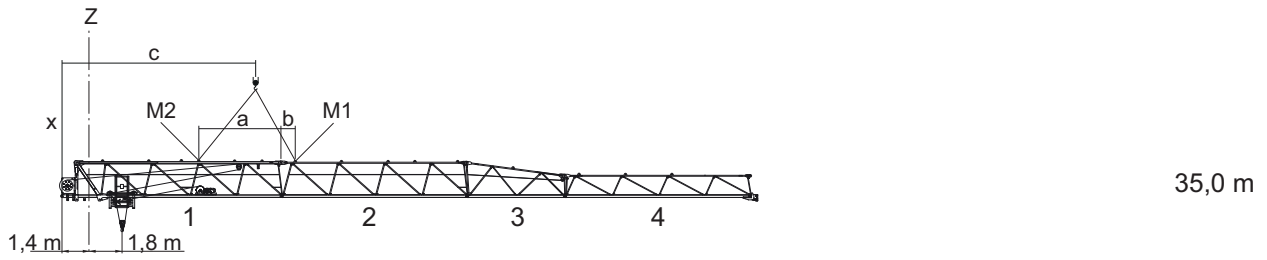

a	Dimension a	Z	Middle of tower
b	Dimension b	M1	Assembly bracket type 1
c	Dimension c	M2	Assembly bracket type 2
X	Pivot point counterjib		

Data	Jib length [m]		
	35.0	32.5	30.0
a [m]	4.43	3.40	4.45
b [m]	0.57	1.03	1.03
c [m]	10.09	9.08	8.31
Weight [kg]	6705	6485	6285

## 8 Assembly diagrams

### 8.1.2.4 Trolley jib - attachment diagram 27.5 m to 25.0 m

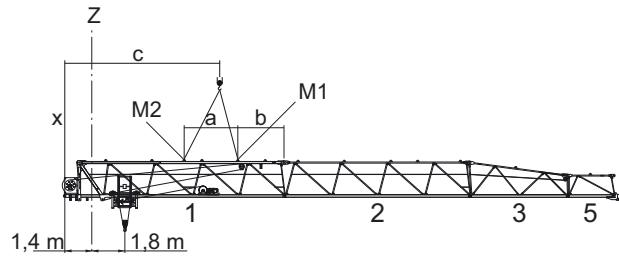

27,5 m

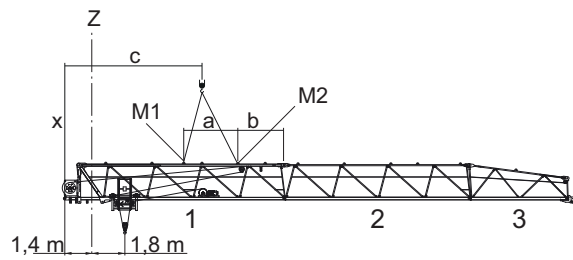

25,0 m

a	Dimension a	Z	Middle of tower
b	Dimension b	M1	Assembly bracket type 1
c	Dimension c	M2	Assembly bracket type 2
X	Pivot point counterjib		

Data	Jib length [m]	
	27.5	25.0
a [m]	2.90	2.90
b [m]	2.58	2.58
c [m]	8.15	7.41
Weight [kg]	6215	6015

## 8.1.3 Assembly of the entire jib with counterjib

### 8.1.3.1 Trolley jib - attachment diagram 50.0 m to 45.0 m

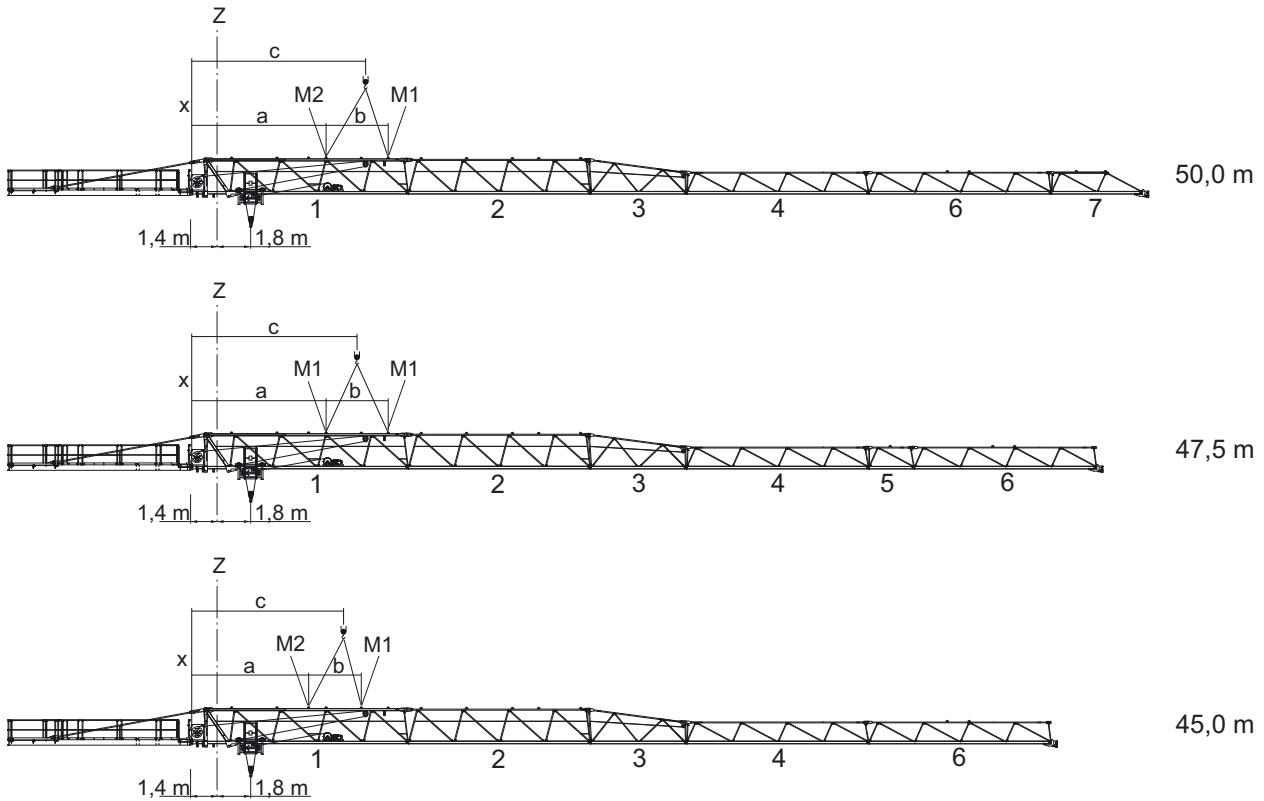

a	Dimension a	Z	Middle of tower
b	Dimension b	M1	Assembly bracket type 1
c	Dimension c	M2	Assembly bracket type 2
X	Pivot point counterjib		

Data	Jib length [m]		
	50.0	47.5	45.0
a [m]	7.38	7.38	6.33
b [m]	3.40	3.40	2.90
c [m]	9.40	9.08	8.15
Weight [kg]	10207	10137	9937

## 8 Assembly diagrams

### 8.1.3.2 Trolley jib - attachment diagram 42.5 m to 37.5 m

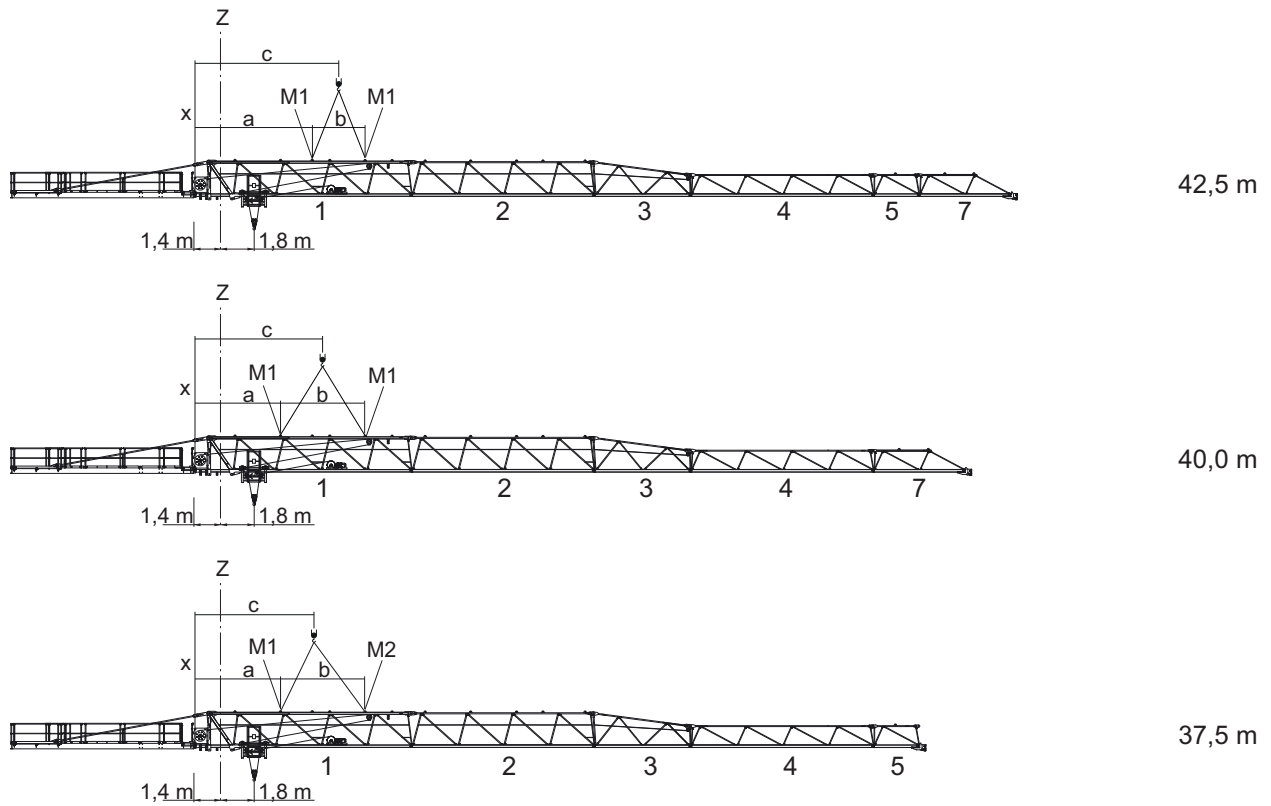

a	Dimension a	Z	Middle of tower
b	Dimension b	M1	Assembly bracket type 1
c	Dimension c	M2	Assembly bracket type 2
X	Pivot point counterjib		

Data	Jib length [m]		
	42.5	40.0	37.5
a [m]	6.33	4.63	4.63
b [m]	2.90	4.60	4.60
c [m]	7.78	6.93	6.70
Weight [kg]	9802	9602	9532

### 8.1.3.3 Trolley jib - attachment diagram 35.0 m to 30.0 m

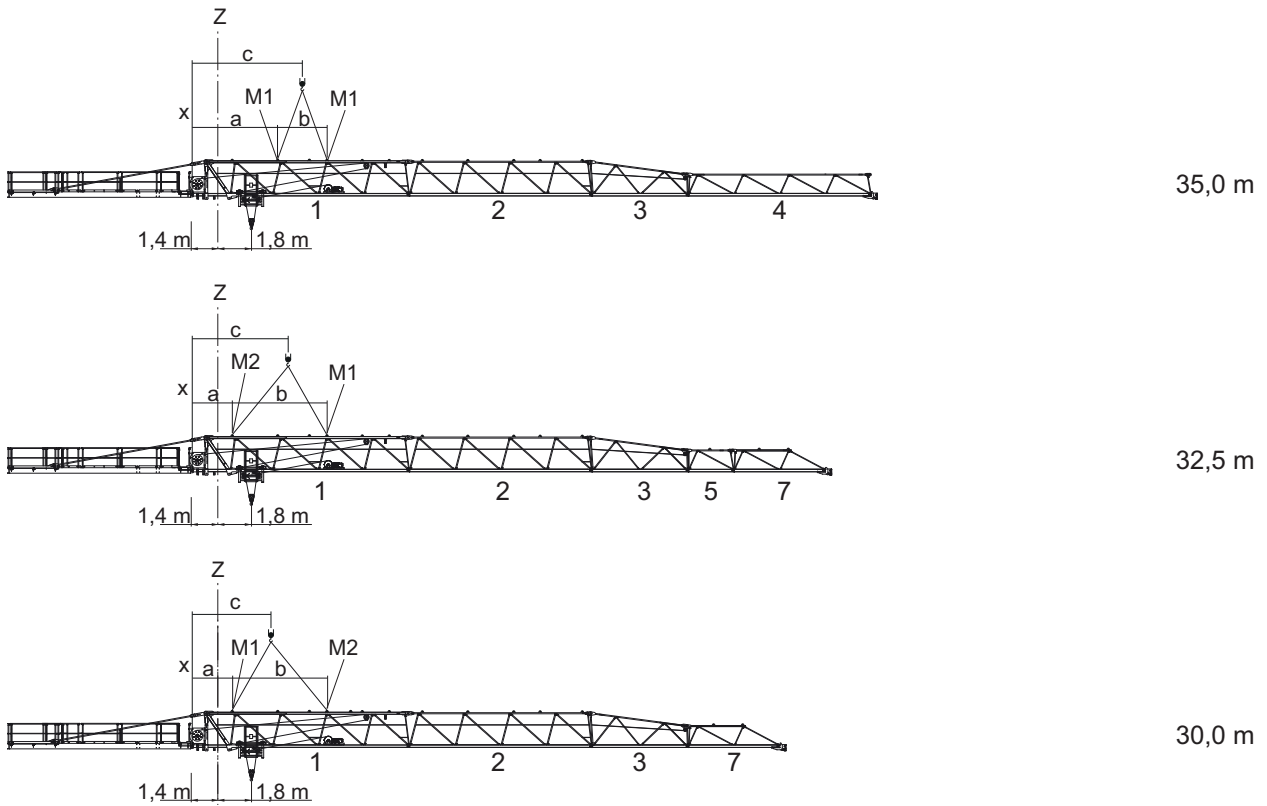

a	Dimension a	Z	Middle of tower
b	Dimension b	M1	Assembly bracket type 1
c	Dimension c	M2	Assembly bracket type 2
X	Pivot point counterjib		

Data	Jib length [m]		
	35.0	32.5	30.0
a [m]	4.63	2.13	2.13
b [m]	2.75	5.25	5.25
c [m]	6.01	4.96	4.55
Weight [kg]	9332	9112	8912

## 8 Assembly diagrams

### 8.1.3.4 Trolley jib - attachment diagram 27.5 m to 25.0 m

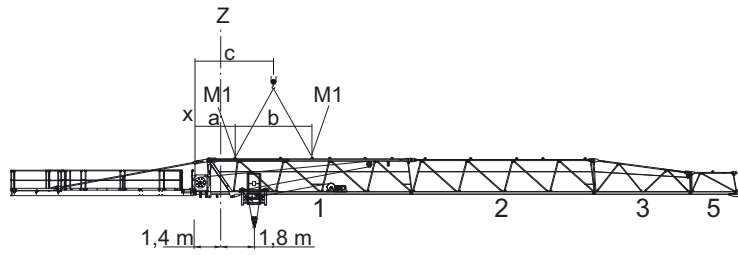

27,5 m

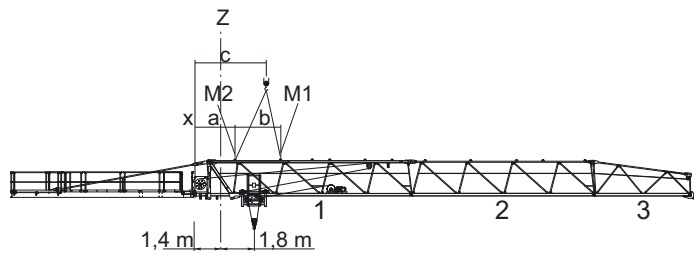

25,0 m

a	Dimension a	Z	Middle of tower
b	Dimension b	M1	Assembly bracket type 1
c	Dimension c	M2	Assembly bracket type 2
X	Pivot point counterjib		

Data	Jib length [m]	
	27.5	25.0
a [m]	2.13	2.13
b [m]	4.20	2.50
c [m]	4.23	3.81
Weight [kg]	8842	8642



## 8.2 Counterjib lifting diagram

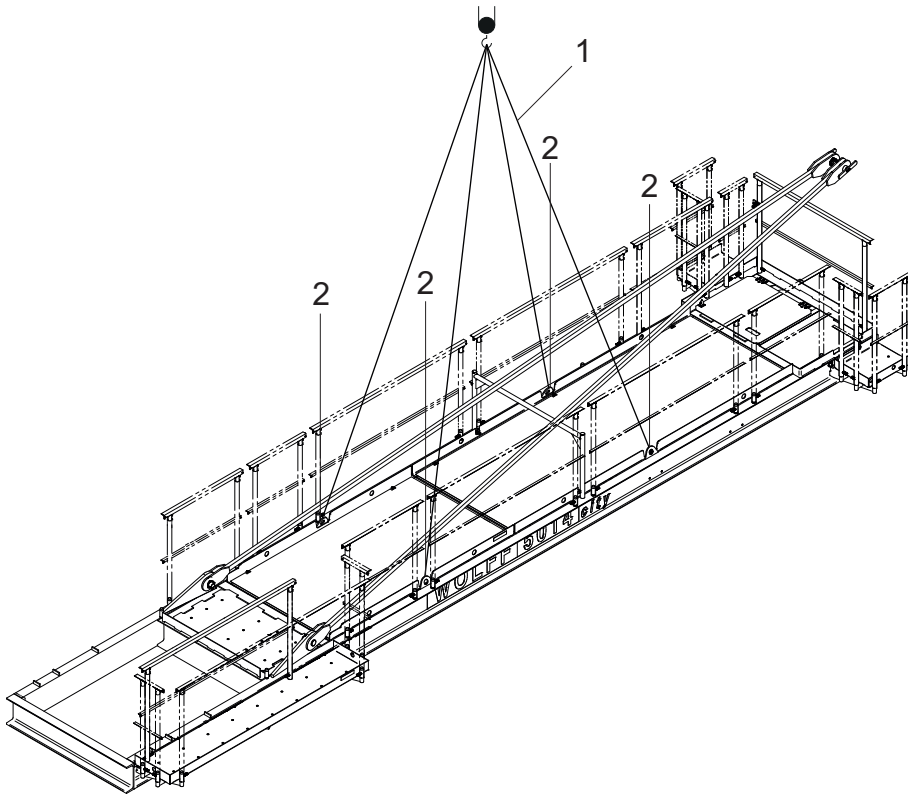

1	Four-point lifting tackle (4 m with shackle)	2	Lifting eyes
---	--	---	--------------

## 8 Assembly diagrams

### 8.3 Counterjib brace diagram

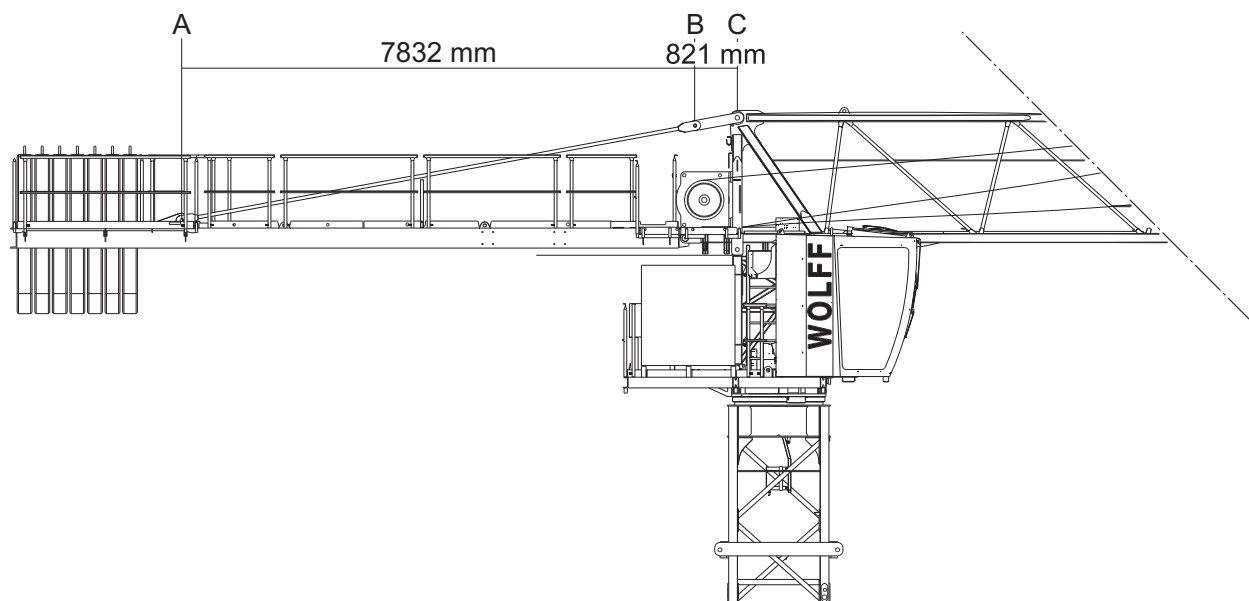

Double bracing

Bolt table

Bolts			Retaining element	
Ref.	Quantity	Dimension [mm]	Quantity	Dimension [mm]
A	2	Collar bolt $\varnothing$ 60/50x130	2	Locking pin 10x175
B	2	Collar bolt $\varnothing$ 60/50x130 with handle	2	Locking pin 10x175
			2	Washers $\varnothing$ 70/51x4
C	1	Collar bolt $\varnothing$ 80/70x195	1	Locking pin 10x100

## 8.4 Trolley jib assembly brackets

	<b>NOTICE</b>
	<p>For information on the arrangement of the assembly brackets, refer to the attachment diagram.</p> <p>Two assembly brackets per slewing tower crane are required to attach the jib. Three assembly brackets are supplied with the crane.</p>

### Elements required for each assembly bracket

Pcs.	Item	Dimensions	Item no.
1	Collar bolt	Ø 40/30x68	30042636
1	Linch pin	6x42	10029909

### Assembly bracket 1 - 2 x per crane

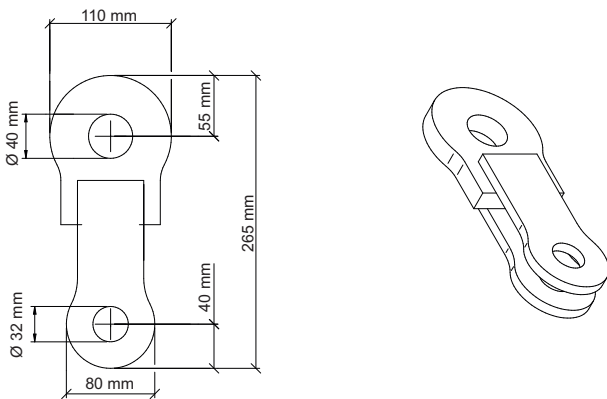

### Assembly bracket 2 - 1 x per crane

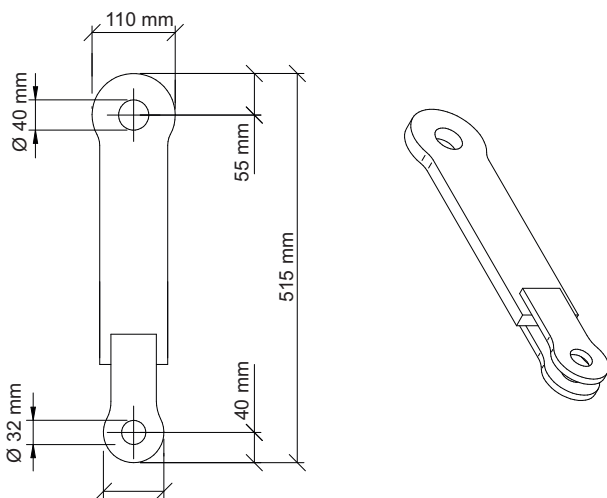

## 8 Assembly diagrams

### 8.5 Arrangement of standard railings

#### 8.5.1 Standard railings (NG) and accessories

Quantity	Standard railings (NG)
1	Flagpole holder F
5	Standard posts (NP)
9	Standard railing350
5	NG 500
3	Standard railing750
7	Standard railing 1000
2	Standard railing1500
5	Standard railing2000
1	Standard railing2500

## 8.5.2 Arrangement of standard railings

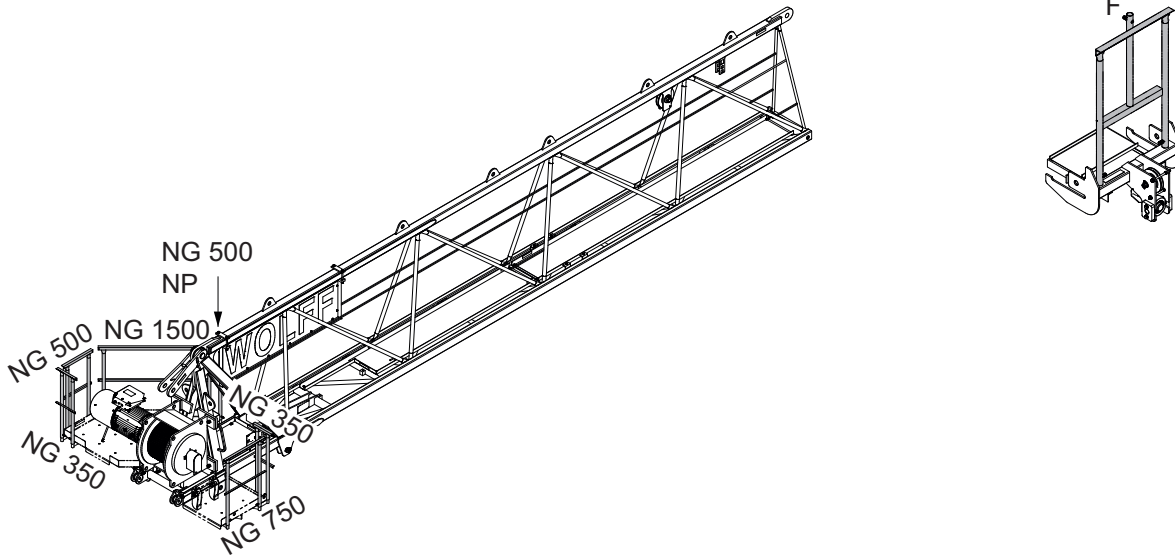

Standard railings jib element 1 and rope swivel crossbeam

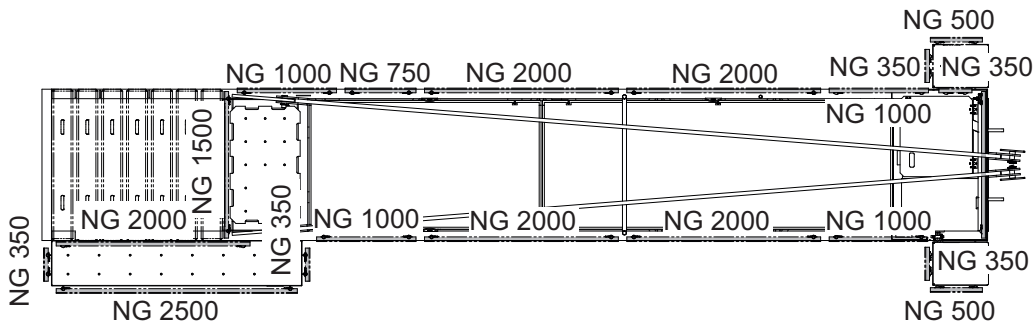

Standard railings at counterjib

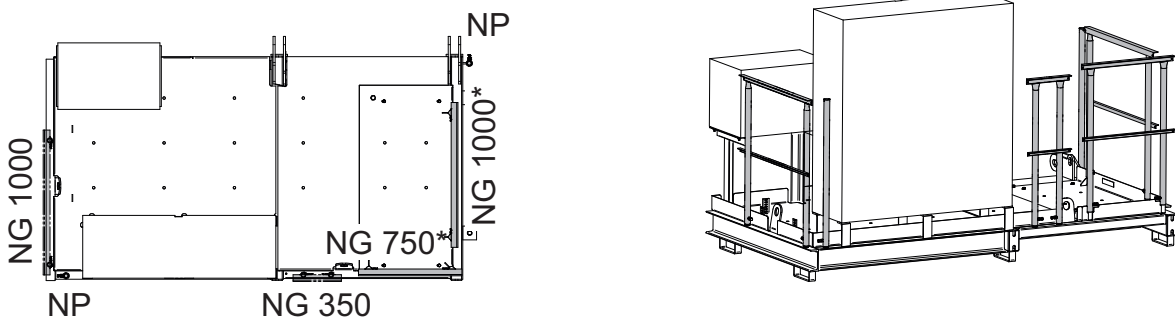

Standard railings control cabinet platform / \* not applicable when driver's cab is used

## 8 Assembly diagrams

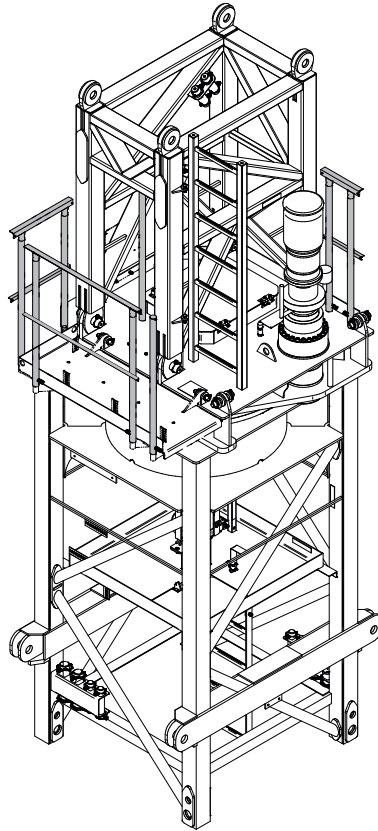
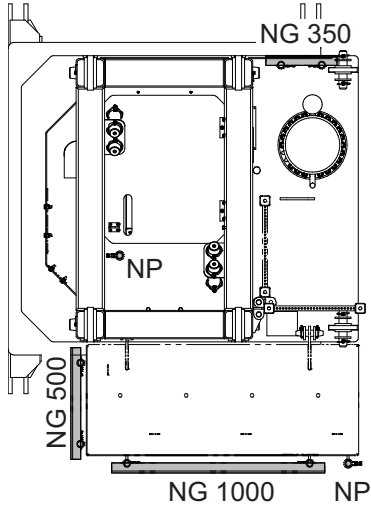



Standard railings tower top

## 9 Suitable climbing devices



This section contains information on

- Outer climbing devices (KWH)
- Inner climbing devices (KSH)

	<p><b>NOTICE</b></p> <p>The operating radius specified is measured from the tower center and is to be considered a reference value. Exact balancing can be achieved by changing the operating radius with the tower elements or loads specified in the table.</p>
	<p><b>NOTICE</b></p> <p>Details for climbing balancing</p> <p>The climbing balancing details apply to the snatch block in maximum hook position.</p>
	<p><b>NOTICE</b></p> <p>If feasible, you should preferably operate your climbing device without balancing weight.</p>

## 9 Suitable climbing devices

### 9.1 Outer climbing devices

	<p><b>⚠ DANGER</b></p> <p>Climbing device attached to the lower part of the tower head section lower part. Increased wind surface. The slewing tower crane may overturn.</p> <ol style="list-style-type: none"><li>1) Lower the climbing device down on the tower, or</li><li>2) dismantle the climbing device.</li></ol>
	<p><b>NOTICE</b></p> <p>Tower element on the transfer carriage</p> <p>The data on climbing balance was specified under the assumption that a tower element is on the transfer carriage.</p>



## 9.1.1 Outer climbing device KWH 15.2

	<b>NOTICE</b>
	<p>Minimum height for stationary setup: 2 tower elements = 9.0 m tower height</p> <p>Minimum height for travelling setup: 2 tower elements + undercarriage approx. 13.5 m tower height</p>

### Climbing radius for the balancing weights

	Jib length [m]										
	50.0	47.5	45.0	42.5	40.0	37.5	35.0	32.5	30.0	27.5	25.0
TFS 15 = 1.41 t	8.8	11.1	16.1	19.5	14.1	15.7	19.9	14.3	17.7	19.0	-
Weight = 5.00 t	-	-	4.9	6.1	4.2	4.8	6.2	4.3	5.5	5.9	7.0

## 9 Suitable climbing devices

### 9.2 Inner climbing devices

	<b>NOTICE</b>
	The data required and the instructions for tower assemblies with inner climbing device is available in the separate description of the inner climbing device.

**DANGER! Observe the special tower combination for the inner climbing device.**

	<b>NOTICE</b>
	Clamping forces for the inner climbing device (KSH) are specified based on a building height of < 190m and wind category C 25

### 9.2.1 Inner climbing device KSH 15

Tower combinations for slewing tower cranes with inner climbing device.

Item				
1	TFS 15	TFS 15	TFS 15	TFS 15
2	TFS 15	TFS 15	TFS 15	TFS 15
3	TFS 15	TFS 15	TFS 15	TVA 15
4	TFS 15	TFS 15	TVA 15	
5	TFS 15	TVA 15		
6	TVA 15			
inner climbing device	KSH 15	KSH 15	KSH 15	KSH 15
Foundation	FUA 120 type C-120	FUA 120 type C-120	FUA 120 type C-120	FUA 120 type C-120
Tower height [m]	41.9	37.4	32.9	28.4
Hook height above ground [m]	44.9	40.4	35.9	31.4

	Jib length [m]										
	50.0	47.5	45.0	42.5	40.0	37.5	35.0	32.5	30.0	27.5	25.0
TFS 15 = 1.41 t	28.6	30.8	35.7	-	-	-	-	-	-	-	-
UV 15 = 1.75 t	24.2	26.1	30.2	33.1	27.6	29.0	-	-	-	-	-
Weight = 5.0 t	9.8	10.6	12.2	13.4	11.2	11.8	13.1	10.9	12.0	12.5	13.5

## 9 Suitable climbing devices

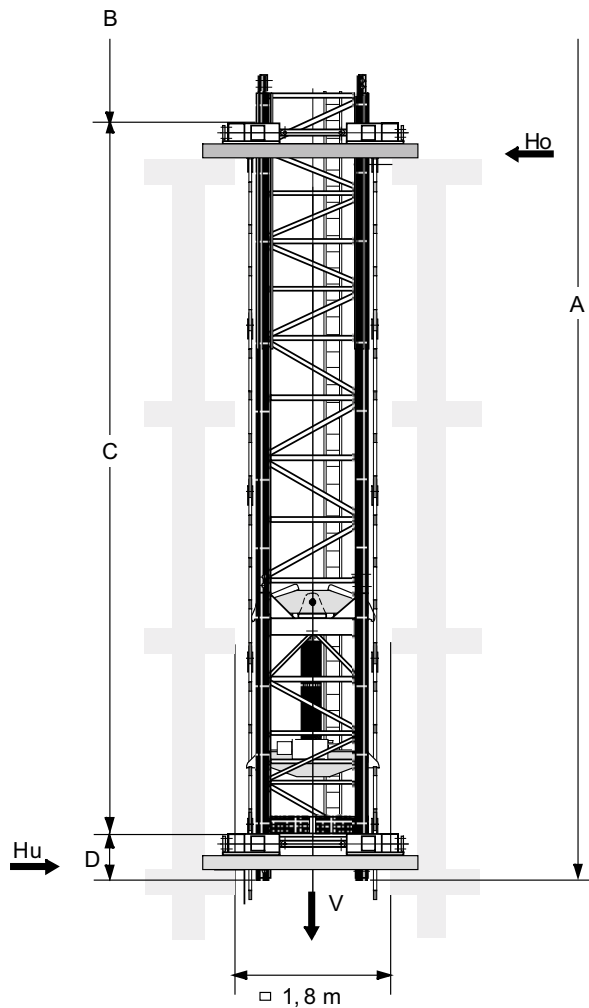

$$C_{\min} = 9,0 \text{ m}$$

$$C_{\max} = 14,0 \text{ m}$$

$$H_o = \frac{M}{C} + H$$

$$H_u = H_o - H$$

$$T = \frac{M_D}{2 \times b}$$

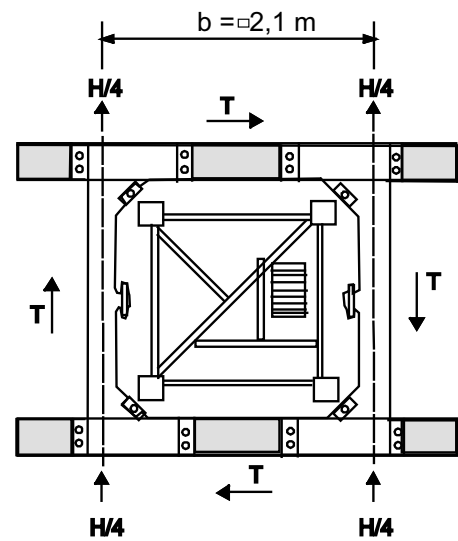

A	= Tower height	C	= Distance between guide frames
B	= A-C-D		

## In service clamping forces

In service clamping forces [kN] inside a building														
A (m)	41.9							37.4						
C (m)	9.0	10.0	11.0	12.0	13.0	14.0	9.0	10.0	11.0	12.0	13.0	14.0		
V (kN)	549							536						
Ho (kN)	180	160	150	130	120	120	160	150	140	120	120	110		
Hu (kN)	150	140	120	110	100	90	140	130	110	100	90	80		
T (kN)	27							27						

Operational clamping forces [kN] inside a building														
A (m)	32.9							28.4						
C (m)	9.0	10.0	11.0	12.0	13.0	14.0	9.0	10.0	11.0	12.0	13.0	14.0		
V (kN)	523							510						
Ho (kN)	150	140	120	110	110	100	140	130	120	110	100	90		
Hu (kN)	130	120	100	90	80	80	120	110	100	90	80	70		
T (kN)	27							27						



## Out of service clamping forces

Out of service clamping forces [kN] inside a building												
A (m)	41.9						37.4					
C (m)	9.0	10.0	11.0	12.0	13.0	14.0	9.0	10.0	11.0	12.0	13.0	14.0
V (kN)	484						471					
Ho (kN)	420	380	350	320	290	270	360	320	300	270	250	230
Hu (kN)	290	250	210	180	160	140	230	200	170	150	120	110
T (kN)	-						-					

Out of service clamping forces [kN] inside a building												
A (m)	32.9						28.4					
C (m)	9.0	10.0	11.0	12.0	13.0	14.0	9.0	10.0	11.0	12.0	13.0	14.0
V (kN)	458						445					
Ho (kN)	320	280	260	240	220	200	290	260	240	220	200	190
Hu (kN)	200	170	140	120	100	90	180	150	130	110	90	80
T (kN)	-						-					

## 10 Arrangement of counterweight blocks

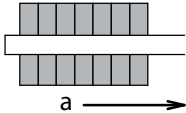
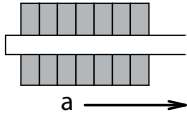
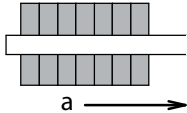
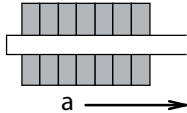
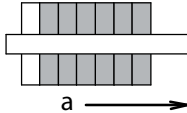
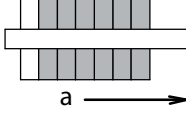
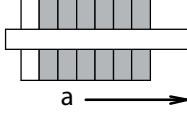
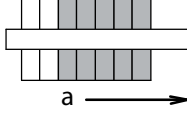
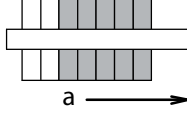
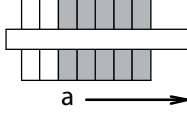
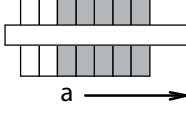
### 10 Arrangement of counterweight blocks

<b>L = 50 m</b>	<b>L = 47.5 m</b>	<b>L = 45 m</b>	<b>L = 42.5 m</b>	<b>L = 40 m</b>
7 x 1.8 t	7 x 1.8 t	7 x 1.8 t	7 x 1.8 t	6 x 1.8 t
				
W = 12.6 t	W = 12.6 t	W = 12.6 t	W = 12.6 t	W = 10.8 t
<b>L = 37.5 m</b>	<b>L = 35 m</b>	<b>L = 32.5 m</b>	<b>L = 30 m</b>	<b>L = 27.5 m</b>
6 x 1.8 t	6 x 1.8 t	5 x 1.8 t	5 x 1.8 t	5 x 1.8 t
				
W = 10.8 t	W = 10.8 t	W = 9.0 t	W = 9.0 t	W = 9.0 t
<b>L = 25 m</b>				
5 x 1.8 t				
				
W = 9.0 t				
L	Jib length [m]	a	To the tower	
G	Total weight [t]		Counterweight	
	No counterweight			



**WOLFFKRAN Group**

*Headquarter international:*

**WOLFFKRAN AG**

Baarermattstraße 6

CH-6300 Zug

Switzerland

Phone +41 41 766 85 00

Fax +41 41 766 85 99

[info@wolffkran.com](mailto:info@wolffkran.com)

*Manufacturing:*

**WOLFFKRAN GmbH**

Austraße 72

D-74076 Heilbronn

Germany

Phone + 49 7131 9815 0

Fax + 49 7131 9815 355

[info@wolffkran.de](mailto:info@wolffkran.de)

**WOLFFKRAN Werk Brandenburg GmbH**

Frederik-Ipsen-Straße 5

D-15926 Luckau OT Altno

Germany

Phone + 49 35456 674 0

Fax + 49 35456 674 200

[info@wolffkran.de](mailto:info@wolffkran.de)