

7,000 • 8,000 • 10,000 • 12,000 lbs

Yale ERC-HH Series

This series of trucks is available in four configurations to meet and exceed your material handling application requirements. The Yale ERC-HH electric truck delivers maximum performance for demanding applications that require clean, quiet-running, heavy-duty capability. These trucks are extremely maneuverable and offer plenty of power and high stacking ability, while also offering excellent ergonomics, reliability and maintenance ease.

AC Transistor Traction Control

AC technology offers smooth acceleration with seamless direction change, proportional regenerative braking and the Auto Deceleration System (ADS). The controller converts battery power to three-phase AC power, and adjusts frequency and currents to meet performance demands. Performance control settings and extensive diagnostics are accessible by technicians through the dash display or a PC. A Master Controller, utilizing Controller Area Network (CANbus) technology, monitors and controls key truck components and systems. The sophisticated Thermal Management System monitors component temperature and gradually adjusts performance to prevent damage to key components.

Controller Area Network (CANbus)

CANbus technology streamlines communications between truck systems through one main master controller. Dash display, traction controller and pump controller are

all regulated via the CANbus network. A connection point is provided for interface with a service PC.

Electrical System

The ERC-HH utilizes AC Motor technology designed for exceptional performance. It uses a brushless induction motor for high starting torque and smooth rapid acceleration. A speed sensor built into the motor provides feedback to the control system, allowing motor speed and direction to be continuously monitored. The standard Auto Deceleration System automatically slows the truck when the operator's foot is removed from the pedal, thereby extending brake life.

Brake System

Duo-servo hydraulic brakes are self-adjusting and self-energizing for reduced pedal effort. The master cylinder is sealed to prevent contamination. A hand-operated park brake is manually adjustable and has an audible warning if the operator leaves the truck without applying the brake. An optional seat-activated, electronically-controlled park brake is available, which engages the brake when the operator leaves the truck.

Voltage

36 or 48 volt systems are available in different battery compartment sizes to meet a variety of application requirements. A solid-state, return-to-neutral feature avoids the possibility of inadvertent truck movement at start-up. The truck will not start forward or rearward until the direction selector lever has been moved through neutral. The truck is equipped with a direction lever on each side of the low profile, tilting steer column.

Dash Display

The dash display includes an hour meter, 40-character LCD display for status codes and descriptions, Battery Discharge Indicator (BDI) with lift interrupt, warning

lights for brake fluid, seat belt indicator, and parking brake indicator. The display also permits access for service technicians to adjust performance control settings, allowing the truck to be customized to meet customer applications.

Additionally, extensive diagnostics allow service technicians to quickly troubleshoot problems. The optional premium display adds operator selectable performance modes, operator passwords and a pre-shift operator checklist.

Foot Directional Control Pedal (FDC) (optional)

The Foot Directional Control (FDC) pedal is a highly productive directional/accelerator pedal. One pedal allows the operator to change direction and acceleration, reducing operator movement and resulting in increased productivity.

Hydraulic Components

The hydraulic system utilizes an AC transistor controller and a brushless AC induction motor. A flexible coupling joins the motor to the pump for long drive life and low noise. The motor and pump are mounted on rubber isolators for reduced noise and vibration. A combination of flexible wire-braid hoses and steel tubing is used to simplify the hydraulic plumbing. These hydraulic lines are carefully routed and held in place to reduce possible damage. A dip-stick allows easy checking of hydraulic oil without the use of tools. A 10-Micron full flow hydraulic filter located in the return line protects the hydraulic system from contaminants and helps provide long life. A by-pass relief valve permits oil flow in the event of the filter clogging.

On-Demand Power Steering

On-demand power steering is standard and the all-hydraulic design gives precise, reliable control while eliminating mechanical linkages and road shocks at the steering wheel. A five-position tilt steering column provides excellent operator comfort and visibility. A brushless motor operates at a very low speed when not in use, conserving energy and reducing noise levels.



Truck shown with optional equipment

continued on back

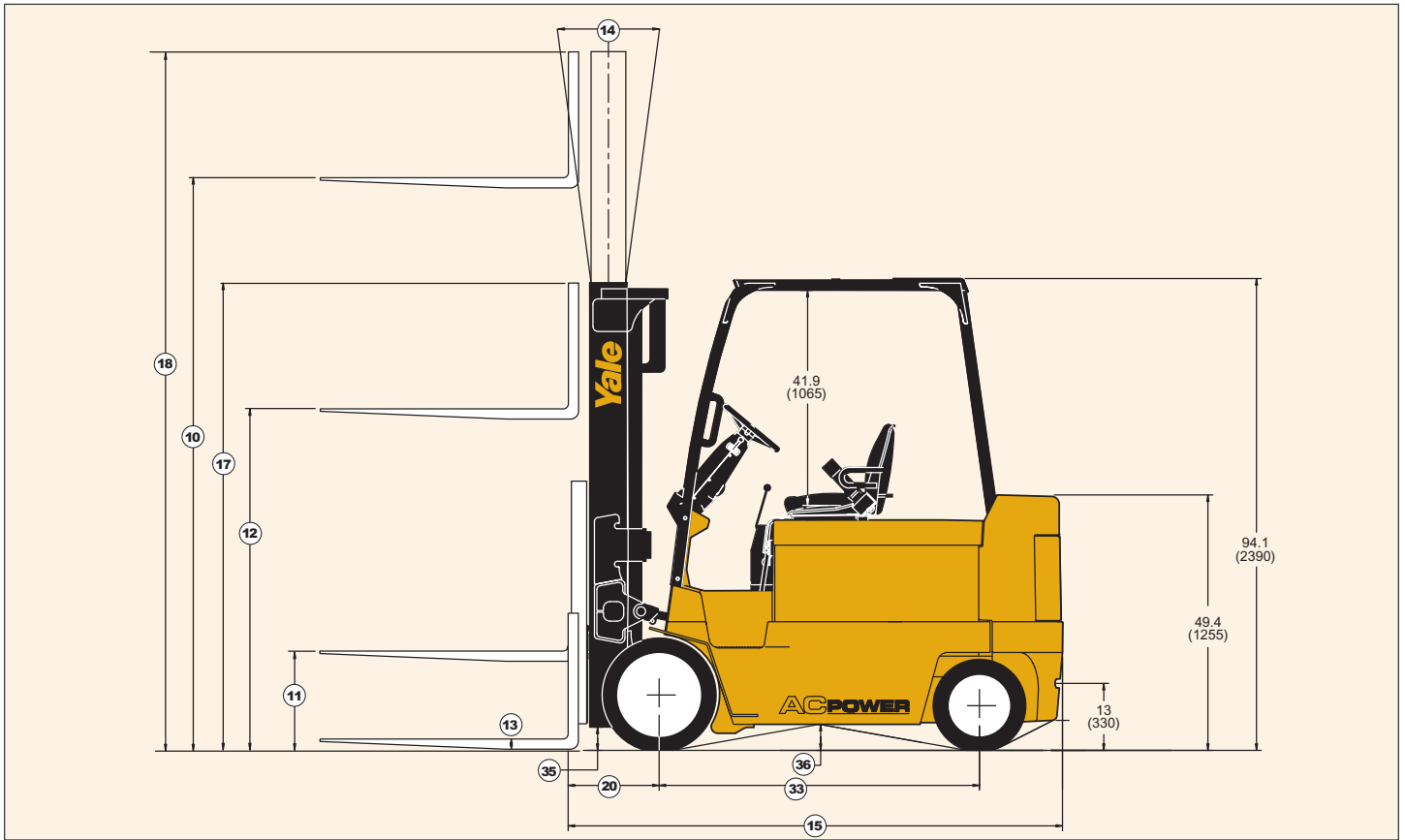

GENERAL	1	Manufacturer	Manufacturer's name	
	2	Model	Manufacturer's designation	
	3	Capacity	Rated Capacity	
DIMENSIONS	4	Load Center	Distance	
	5	Power Type	Electric	
	6	Operator Type	Sit	
	7	Tire Type	Cushion, Solid, Pneumatic, etc.	
	8	Wheels	Number (X=driven) Front/Rear	
	10	Upright Lift	Standard Lift (Top of Fork)	in. (mm)
	11		Standard Free Fork Height	in. (mm)
	12		Opt. Free Lift (TOF) W-W/O LBR	in. (mm)
	13	Forks	Width/Thickness	in. (mm)
	14	Tilt Angle	Standard Upright - Forward/backward	Degrees
15	Overall Dimensions	Length to Face of Forks	in. (mm)	
16		Width (Standard Tires)	in. (mm)	
17		Height Std. Upright Lowered	in. (mm)	
18		Hgt. Std. upright Ext-W-W/O LBR	in. (mm)	
19	Turning Radius	Minimum (Outside)	in. (mm)	
20	Load Distance	Center of Wheel to Face of Forks	in. (mm)	
21	Aisle Width	(Add Load Length for Right Angle Stacking)	in. (mm)	
PERFORMANCE	22	Stability	Comply with ANSI?	
	23	Voltage		
	24	Speed	Travel Speed Std- No Load/With Load	mph (km/h)
	25		Travel Speed Max- No Load/With Load	mph (km/h)
	26		Lift Speed - No Load/With Load	ft/min (m/s)
	27		Lowering Speed - No Load/With Load	ft/min (m/s)
	28	Total Approx Weight	Standard Truck (W/O Battery)	lb. (kg)
29	Axle Loading	Static W/Rated Load-Front/Rear (Max Batt)	lb. (kg)	
WHEELS & TIRES	30	Tires	Number - Front/Rear	
	31		Size Front	
	32		Size Rear	
	33	Wheelbase	Distance	in. (mm)
	34	Tread	Center of Tires - Front/Rear	in. (mm)
	35	Ground Clearance	Lowest Point	in. (mm)
36	No Load at Center of Wheelbase		in. (mm)	
TRANS. & POWER UNIT	37	Brakes	Service/Parking - Method of Control	
	38		Service/Parking - Method of Operation	
	39	Battery	Voltage	
	40		Type	
	41		Volts/Ampere Hrs (Max)	v/ah
	42		Minimum Weight	lb. (kg)
	43	Electric Motors	Drive Motor - 60 Min Rating	hp. (kw)
	44		Pump Motor - 15-Min Rating	hp. (kw)
45	Drive & Hyd. Pump Motor Control Method			
46	Number of Speeds			
47	Relief Pressure	For Attachments	psi/kPA	

Yale	
ERC070HH	
7000 (3175)	
24 (610)	
Electric	
Sit	
C/C	
2X/2	
122 (3100)	
5.9 (150)	
35.7 (906) / 55.5 (1359)	
5.0 (130) / 2.0 (50)	
5 / 5	
93.6 (2377)	
46.1 (1171)	
84 (2134)	
170.4 (4328) / 150.6 (3526)	
82.6 (2099)	
17.5 (444)	
100.2 (2546)	
YES	
36V	48V
8.8 (14.1) / 8.0 (12.9)	10.4 (16.7) / 10.3 (16.6)
10.2 (16.4) / 9.4 (15.1)	10.4 (16.7) / 10.4 (16.7)
91 (.46) / 52 (.26)	118 (.60) / 76 (.39)
95.0 (.48) / 104.0 (.53)	95.0 (.48) / 104.0 (.53)
10052 (4559)	
18350 (8325) / 3620 (1645)	
2 / 2	
22 X 9 X 16	
18 X 6 X 21.1	
62 (1575)	
37.1 (942) / 39.5 (1003)	
4.5 (114)	
5 (127)	
Hydraulic / Mechanical	
Foot / Hand	
36V	48V
Lead Acid	Lead Acid
1800	1400
3400 (1542)	3400 (1542)
28.8 (22)	
31.6 (24)	
A/C	
Infinitely variable	
2250 / 15515	

36V	
8.6 (13.8) / 7.7 (12.4)	
10.1 (16.2) / 9.1 (14.6)	
118 (.60) / 77 (.39)	
95.0 (.48) / 104.0 (.53)	
19850	
37.1 (942)	
Hydra	
36V	
Lead Acid	
1800	
3400 (1542)	
Int	

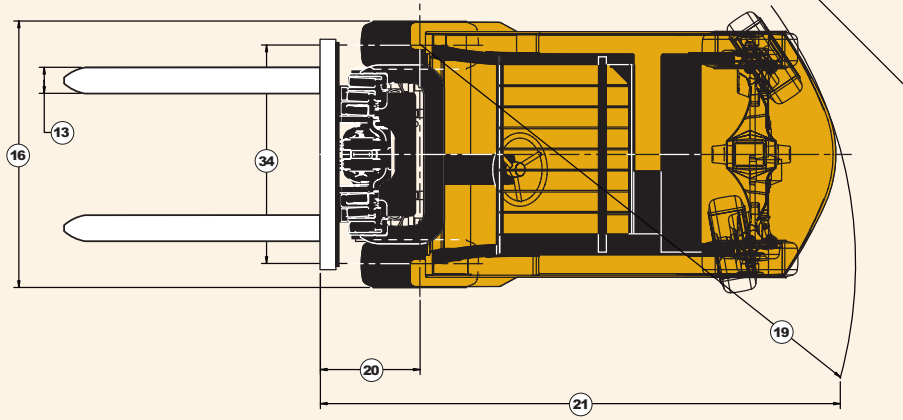

DIMENSION KEY (applies to this view only)
 A = Equal intersecting right angle aisle
 L = Load length
 R = Outside turning radius
 T = Tread width
 W = Overall width

Yale	
ERC080HH	
8000 (3629)	
24 (610)	
Electric	
Sit	
C/C	
2X/2	
122 (3100)	
5.9 (150)	
906 / 55.5 (1359)	
(130) / 2.0 (50)	
5 / 5	
95.6 (2428)	
46.1 (1192)	
84 (2134)	
328 / 150.6 (3526)	
84.2 (2139)	
17.5 (444)	
101.8 (2586)	
YES	
48V	
10.4 (16.7) / 9.9 (15.9)	
10.4 (16.7) / 10.4 (16.7)	
118 (.60) / 77 (.39)	
95.0 (.48) / 104.0 (.53)	
11067 (5020)	
9023 / 4130 (4177)	
2 / 2	
22 X 9 X 16	
18 x 7 x 21.1	
62 (1574)	
942 / 39.5 (1003)	
4.5 (114)	
5.1 (130)	
Hydraulic / Mechanical	
Foot / Hand	
48V	
Lead Acid	
1400	
3400 (1542)	
28.8 (22)	
31.6 (24)	
A/C	
Infinitely variable	
2250 / 15515	

Yale	
ERC100HH	
10000 (4536)	
24 (610)	
Electric	
Sit	
C/C	
2X/2	
112.2 (2850)	
5.9 (150)	
35.9 (913) / 48.6 (1234)	
6.0 (150) / 2.0 (50)	
5 / 5	
102.7 (2608)	
52 (1320)	
84.2 (2138)	
160.4 (4075) / 145.7 (3700)	
87.6 (2225)	
18.2 (462)	
104.3 (2649)	
YES	
36V	
8.4 (13.5) / 7.3 (11.7)	
9.7 (15.6) / 8.4 (13.5)	
69 (.35) / 38 (.19)	
73.0 (.37) / 89.0 (.45)	
48V	
10.4 (16.7) / 9.4 (15.1)	
10.4 (16.7) / 10.4 (16.7)	
89 (.45) / 53 (.27)	
73.0 (.37) / 89.0 (.45)	
12400 (5625)	
23470 (10645) / 4400 (1995)	
2 / 2	
22 X 12 X 16	
18 x 7 x 12.1	
62 (1574)	
39.9 (1015) / 40 (1003)	
4.7 (118)	
5.1 (130)	
Hydraulic / Mechanical	
Foot / Hand	
36V	
Lead Acid	
1800	
3600 (1633)	
48V	
Lead Acid	
1400	
3600 (1633)	
28.8 (22)	
31.6 (24)	
A/C	
Infinitely variable	
2250 / 15515	

Yale	
ERC120HH	
12000 (5443)	
24 (610)	
Electric	
Sit	
C/C	
2X/2	
112.2 (2850)	
5.9 (150)	
35.9 (913) / 48.6 (1234)	
6.0 (150) / 2.0 (50)	
5 / 5	
106.8 (2712)	
52 (1320)	
84.2 (2138)	
160.4 (4075) / 145.7 (3700)	
94.7 (2405)	
18.2 (462)	
111.4 (2830)	
YES	
36V	
8.2 (13.2) / 7.0 (11.3)	
11.3 (18.2)	
69 (.35) / 38 (.19)	
73.0 (.37) / 89.0 (.45)	
48V	
10.4 (16.7) / 9.0 (14.5)	
10.4 (16.7) / 10.4 (16.7)	
89 (.45) / 53 (.27)	
73.0 (.37) / 89.0 (.45)	
13870 (6291)	
27180 (12330) / 4850 (2200)	
2 / 2	
22 X 12 X 16	
18 x 7 x 12.1	
68.5 (1740)	
39.9 (1015) / 40 (1003)	
4.7 (118)	
5.1 (130)	
Hydraulic / Mechanical	
Foot / Hand	
36V	
Lead Acid	
2000	
4200 (1905)	
48V	
Lead Acid	
1600	
4200 (1905)	
28.8 (22)	
31.6 (24)	
A/C	
Infinitely variable	
2250 / 15515	

1	GENERAL
2	
3	
4	
5	
6	
7	
8	
10	DIMENSIONS
11	
12	
13	
14	
15	
16	
17	
18	
19	
20	
21	
22	PERFORMANCE
23	
24	
25	
26	
27	
28	
29	W.T.
30	
31	
32	WHEELS & TIRES
33	
34	
35	
36	
37	
38	TRANS. & POWER UNIT
39	
40	
41	
42	
43	
44	
45	
46	
47	

Steering Axle

The steering axle is a one-piece ductile iron casting mounted on elastic cushions that reduce shock and provide a softer ride.

Masts\Carriage\Forks\Load Backrest Extension

Yale Global Hi-Vis simplex, duplex and triplex masts provide excellent visibility. The simplex (2 Stage LFL) and duplex (2 Stage FFL) masts feature flush face design with geometrically matched, angled load rollers, which are canted, yet provide full-face roller contact. The mast front rail flange angle coupled with the inverted "J" inner channel and three degree mast rollers significantly reduces channel web milling and roller wear. Non-metallic mast hanger bushings reduce mounting wear and increase impact strength. Class III and IV six-roller carriages are standard. Forks are "upset forged" from a single piece of high-

strength steel to give added strength and thickness for wear. A 48" load backrest extension is standard.

Frame

The frame is a unitized construction, stress tested for durability. A large, high-traction step is provided for easy entry and exit. The truck has a two-piece floor plate that can be easily lifted out for service access without the use of tools. A large, easily removable counterweight cover gives easy access to componentry. A fiberglass, gas spring-assisted battery cover allows easy changing of the battery. The battery compartment can be fitted with rollers or slides for ease of battery change.

Additional Features on the ERC-HH include an easy entry and exit overhead guard, 42" forks, a contoured bucket type seat (6" fore and aft adjustment) with a hip restraint seat belt and an operator-sensing

switch. A heavy rubber floor mat, electronic horn and ignition lock are also standard.

Options

- Foot Directional Control (FDC) pedal
- Premium dash display
- Seat-activated, electronically-controlled park brake
- Convenience box
- Wide tread
- Semi-suspension seats
- Full suspension seats
- Swivel seats
- Various battery compartments
- Battery rollers/sliders
- Various height overhead guards
- Drive-in rack overhead guard
- Various light packages
- 8° forward tilt
- Integral sideshifter
- 48 volt system
- Alarm – Back-up (87 dBA)
- Light – Amber strobe
- Various type drive tires
- UL type "EE" and "ES" construction

Standard Lift Specifications												
ERC 70-80HH	O.A.H.		Free Fork Height		Max Fork Height		Tilt		Drive Tire Size		O.A.W.	
	Inches	mm	Inches	mm	Inches	mm	Back	Fwd	Inches	Inches	mm	
2 Stg LFL	84	2134	5	150	122	3100	5	5	22 x 9 x 16	46.1	1171	
	96	2434	5	150	145	3700	5	5	22 x 9 x 16	46.1	1171	
2 Stg FFL	84	2134	49	1244	122	3100	5	5	22 x 9 x 16	46.1	1171	
3 Stg FFL	84	2134	53	1359	173	4415	5	5	22 x 9 x 16	50.5	1283	
	88	2235	57	1459	185	4715	5	5	22 x 9 x 16	50.5	1283	
	92	2337	61	1559	194	4950	5	5	22 x 9 x 16	50.5	1283	
	100	2540	69	1759	218	5550	5	5	22 x 9 x 16	50.5	1283	

Denotes Reduced Capacity – Contact your local Yale Industrial Truck Dealer
 Denotes without load backrest – With backrest, subtract 48" from O.A.H.

Truck performance may be affected by the condition of the vehicle, how it is equipped and the application. Consult your Yale Industrial Truck Dealer if any of the information shown is critical to your application. Specifications are subject to change without notice.

This truck meets all design specifications of ANSI B56.1 Safety Standard for Powered Industrial Trucks at the time of manufacture. Classified by Underwriters' Laboratories, Inc. as to fire hazard only for type "E" and optional "EE" and "ES" for industrial trucks.

Standard Lift Specifications												
ERC 100-120HH	O.A.H.		Free Fork Height		Max Fork Height		Tilt		Drive Tire Size		O.A.W.	
	Inches	mm	Inches	mm	Inches	mm	Back	Fwd	Inches	Inches	mm	
2 stg LFL	84	2134	6	160	112	2850	5	5	22 x 12 x 16	52	1321	
	96	2434	6	160	135	3450	5	5	22 x 12 x 16	52	1321	
	108	2734	6	160	159	4050	5	5	22 x 12 x 16	52	1321	
2 Stg FFL	84	2134	48	1234	112	2850	5	5	22 x 12 x 16	52	1321	
	96	2434	60	1534	135	3450	5	5	22 x 12 x 16	52	1321	
3-Stg FFL	84	2134	48	1229	163	4147	5	5	22 x 12 x 16	56	1422	
	92	2334	56	1429	185	4700	5	5	22 x 12 x 16	56	1422	
	100	2534	64	1629	208	5300	5	5	22 x 12 x 16	56	1422	

Denotes without load backrest – With backrest, subtract 48" from O.A.H.

Model		Lift speeds				Lowering speeds	
		36 Volt		48 Volt		36/48	
		rated load	no load	rated load	no load	rated load	no load
7000	2-stg LFL	54	91	76	118	104	95
	2-stg FFL	51	84	71	109	90	74
	3-stg	51	86	72	106	98	77
8000	2-stg LFL	52	91	73	118	104	95
	2-stg FFL	49	84	68	109	90	74
	3-stg	49	86	69	106	98	77
10000	2-stg LFL	40	69	57	89	89	73
	2-stg FFL	39	64	54	82	80	58
	3-stg	39	64	54	80	86	63
12000	2-stg LFL	38	69	53	89	89	73
	2-stg FFL	36	64	50	82	80	58
	3-stg	36	64	50	80	88	63

Model	Compartment Size	Battery Specifications*												
		Width	Length	Height	Size Min/Max		Dim "Z"	Voltage	Max Amp Hr	Weight				
					Dim "X"	Dim "Y"				Min	Max			
ERC 70-80HH	Standard	44.10	39.20	23.15	37.40	43.98	37.40	38.98	22.20	23.03	36	1800	3400	4800
											48	1400	3400	4800
ERC 100HH	Standard	44.10	39.20	23.15	37.40	43.98	37.40	38.98	22.20	23.03	36	1800	3600	4800
											48	1400	3600	4800
ERC 120HH	Optional	44.10	45.70	23.15	37.40	43.98	43.90	45.28	22.20	23.03	36	2000	4000	5550
											48	1600	4000	5550
ERC 120HH	Standard	44.10	45.70	23.15	37.40	43.98	43.90	45.25	22.20	23.03	36	2000	4200	5550
											48	1600	4200	5550

* Smaller batteries may require capacity reduction.

36-volt battery uses Anderson SB-350 Gray connector with manual release, lead position "B" – 30" long.
 48-volt battery uses Anderson SB-350 Blue connector with manual release, lead position "B" – 30" long.



Yale Materials Handling Corporation
 P.O. Box 7367, Greenville, North Carolina 27835-7367

2362-1-3/07-2500
 Copyright 2007
 Yale Materials Handling Corporation
 Printed in U.S.A.

Manufactured in our own ISO 9001:2000 Registered Facilities

Courtesy of Crane.Market