



YANMAR

CARRIER

C50R-5



	C50R-5	C50R-5 TV
Operating weight	5791 kg	6117 kg
Payload	3800 kg	3500 kg
Engine	Yanmar direct injection, diesel 4TNV94CHT-NTBC	

C50 THE ALL-TERRAIN CARRIER



COMPACTNESS

The C50R-5 has very compact dimensions with a width of 2200 mm and a total length of 4540 mm.



TRANSMISSION CONCEPT

The C50R-5 has drastically improved the concept of its transmission through the addition of the anti-stall feature.



POWERFUL YANMAR ENGINE

The C50R-5 uses the newest version (Y-Harmonizer) of the Yanmar TNV engines. It is a Yanmar 4-cylinder with direct injection and common rail system. This engine is also equipped with a cooled EGR and a DPF, which allow the machine to exceed actual EU emission regulations and to meet already the next EU Stage V level.



BEST COMPONENTS

Developed in Japan with renowned components for top quality. Design and performance of the components are made for heavy-duty job sites and long service life.



EASE OF MAINTENANCE

Simple maintenance structure for fast and easy access to all components. Facilitated daily checks.



FOR EXTREME CONDITIONS



CABIN

The last generation of C50 received a lot of attention to increase the operator's comfort. The configuration of the instrumentation has improved with a better lay-out of the switches and a new LED display.



EASY OPERATION

The operator seat and the travel levers can both rotate by 180°, giving the operator the possibility to always face the travel direction.



ENGINE SPEED CONTROL

The engine speed is automatically adjusted to the level of load of the transmission.



EXCELLENT STABILITY

The C50R-5 benefits of a very strong undercarriage with automatic hydraulic tensioning. The weight of the machine is evenly distributed via 32 rollers on the ground.



UNMATCHED COMPACTNESS

The C50R-5 is a very compact carrier for its class. It has a total width of 2,2 meters allowing this machine to transport 3800 kg of loading capacity even on very small jobsites. A total length of 4.54 meters makes it easy to turn in every condition, especially with the feature that this machine can spin-turn 360°.

This configuration offers the following benefits:

- Increased efficiency of the machine.
- Increased productivity for the operator.



2200 mm



UNIQUE TRANSMISSION CONCEPT

Yanmar has greatly improved the most important feature of that type of machine: the transmission. The HST transmission integrates an anti-stall feature: automatic hydraulic pressure adjustments allow the C50R-5 to turn 360° smoothly without stalling the engine. The C50R-5 does a 360° spin-turn in as little as 7 seconds.

This feature offers to the customer an improved maneuverability, an increased driving comfort and increases the productivity.

Furthermore, with the engine performance improved by 13,6 % to 113,1 HP, the performance of the transmission received an added reserve of power improving the manoeuvrability of the C50R-5.



4540 mm / 4650 mm (with turning vessel)



MAXIMUM STABILITY AND EXCEPTIONAL LIFTING STRENGTH

The C50R-5 could use the nickname “The light-foot”. This results from his very special undercarriage, where the backbone is composed by a very strong box section structure which provides excellent resistance to torsional bending. The frame is designed for maximum durability.

The total mass of the C50R-5 is evenly distributed on the ground via 32 rollers. Fully loaded, the machine has a ground pressure as little as 32,4 kPa. This improves the all-terrain capabilities drastically and the C50R-5 can work in the worst ground conditions.

The even distribution of the weight on the 32 rollers improves the service life of the tracks.



UNIQUE UNDERCARRIAGE

The C50R-5 is also provided with a hydraulic auto-tensioning system for the tracks suppressing all maintenance related to track tensioning and reducing TCO and service down-time.

To further improve the all-terrain capabilities, track rollers are mounted on free moving bogeys in order to better absorb obstacles. This feature improves the operator comfort and the service life of the undercarriage components.

Rollers and idlers are mounted on sealed tapered roller bearings because they are extremely durable and maintenance free.

Yanmar has increased the width of the undercarriage by 10% to 2200 mm, by keeping the same length. This automatically improves the turning ability and manoeuvrability of the C50R-5, and improves driving comfort and productivity.



C50R-5 with standard wagon



C50R-5 with turning wagon



POWERFUL YANMAR ENGINE

The C50R-5 benefits from the most advanced technology of the leading manufacturer of industrial diesel engines. The 113.1 TNV engine is equipped with direct injection to create clean burning power. It has fully-electronic control to provide the C50R-5 with total intelligent engine control. The engine is also equipped with a common rail system to allow fine-tuned electronic control of fuel injection.

Yanmar re-sized seriously the fuel tank by increasing the capacity by as much as 47,9% to 121,3 liter. This off-course improves the autonomy by the same percentage reducing the downtime due to refuelling.



ELECTRICAL CONTROL SYSTEM EGR AND DPF

Yanmar customers with TNV engines are already fully compliant with EU Stage V requirement, meaning that our engine has already cleaner emission than required today. This achieved through two additional features.

The first is the cooled EGR (Exhaust Gas Recirculation) which reduces drastically the nitrogen oxides (NOx).

The second is the DPF (Diesel Particulate Filter) to clean up exhaust emissions (PM). Yanmar has successfully developed an exclusive regeneration system in order to combat clogging and cleaning down-time.



EASY OPERATION

REVERSIBLE SEAT CONSOLE

The C50R-5 is equipped with a special feature, the operator seat and travel levers can turn 180°, allowing the operator to be always seated in the travel direction:

- It improves the operator comfort
- It improves drastically the safety
- It improves the visibility of the operator
- It improves the productivity of the operator
- It reduces the risk of damages

The travel levers are servo-assisted and can be operated with minimal effort. Furthermore, the long levers contribute to the high precision of operating the transmission reducing operator fatigue and increasing safety and comfort.





OPERATOR STATION

SPACIOUS AND COMFORTABLE CAB

Yanmar has been paying a lot of attention to the operator station by modernizing the look and feel of the newest version of the C50R-5. The operator has more than ample space, even for the legs in order to improve his comfort.

The C50R-5 is standard equipped with a suspension seat.

The front windshield linkage is assisted with gas cylinder which allows easy opening and closing, and improving the operator comfort.

For the new version of the C50R-5, the instrumentation panel has been re-designed, all switches have been re-grouped close to the LED screen in order to improve the visibility for the operator, and make operation more intuitive and safer.



DIGITAL INTERFACE

The new C50R-5 is equipped with a new electronic instrumentation. The machine has a new LED monitor which informs the operator about the critical parameters of the machine. In case of malfunction of one component, the operator will be informed through warning icons.

The new instrumentation informs also the operator about automatic DPF maintenance.

The C50R-5 has also an auto-idle function as a standard equipment in order to reduce fuel consumption and emissions.



FLEXIBILITY

The C50R-5 is available in 2 different configurations:

- The first version is the three-side flaps wagon type where the load is dumped in the rear. It has an incredible dumping angle of 65° and ground clearance of 658 mm. These 2 features insure that it is easy and fast to dump the load from the wagon. Furthermore, all sides can be opened separately.
- The second version is with a swing wagon type. The wagon is mounted on a turning frame which can turn 180° (90° left, 90° right). This feature allows the C50R-5TV to dump the material by driving along a trench, and to get very close to the jobsite while maintaining a distance of security. This feature improves greatly safety and productivity.

Both versions are equipped with a mud guard to avoid any material from falling out of the wagon and damaging hydraulic components, or to ingress the operator area.





SAFETY

The structure of the C50R-5 cabin has been designed to meet the ROPS (Roll-Over Protective Structure) certification as well as the FOPS (Falling Object Protective Structure) level 1. The rear part of the cabin is protected by a grid.

SAFE SERVICE

All maintenance items can be reached from ground level. To access the engine compartment, we have equipped the C50R-5 with safety treads and railing. These measures insure maximum safety even in the most slippery weather conditions.

RELIABILITY

The structure of the undercarriage, as well as the steel covers provide an optimal protection and longer service life. Furthermore, a lot of care has been paid to the hose routing on the working equipment. These measures enhance the service life and reduce downtime of the machine.



LONG SERVICE INTERVALS

Yanmar carriers are designed for working and therefore we increase the service intervals to 500 hours.

For our DPF (Diesel Particulate Filter) the DOC (Diesel Oxidation Catalyst) is maintenance free, and the SF (Soot Filter) needs only to be cleaned every 3000 hours, which reduces downtime.

BEST COMPONENTS

All C50R-5 components were designed in order to make it reliable, durable and capable of performing demanding work.





MAINTENANCE



EASY ACCESS

Daily maintenance has to be performed easily. There are three easy to open panels. They give an access to all major elements: air filter, A/C compressor, radiator, refueling pump, battery, fuel tank, hydraulic oil tank alternator, engine oil dipstick, water separator, coolant level, etc...

The fuses and relays are located in the battery compartment and are easily accessible.



- 01 Air filter 02 Fuse box 03 Engine ECU 04 Battery 05 Coolant Exp Vase 06 DPF 07 Radiator Cap



YANMAR SERVICES



Our distributors provide you all the solutions you need: advice tailored to your situation, including full-service contracts, spare parts and maintenance.

> FINANCING

The **Y-Finance*** solutions guarantee the most competitive interest rates and help you determine the financing plan that best suits your needs.

** The offerings vary by country.*

> WARRANTY

All new Yanmar excavators sold through our authorized network in Europe are protected for 12 months (or 1,000 hours, whichever comes first) by a manufacturer's warranty with an extension of 12 months (or 1,000 hours) for the drive train. We go further by proposing extended warranty contracts "Garantie PLUS" that offer various solutions for long-term coverage.

> PARTS

The original Yanmar parts are designed, tested and manufactured to ensure optimal quality and safety. By systematically using original spare parts, you can be sure to maintain the performance of your machine and avoid future costly repairs due to inadequate parts. You are sure that your machine is kept in perfect condition and you ensure a high resale value.

Available from our distributors, original Yanmar parts can be delivered within 24 hours.

> MAINTENANCE

Proximity, speed, quality and reliability are constant concerns for Yanmar dealers. We are committed to your peace of mind and we are committed to your satisfaction. The network of authorized Yanmar repair sites is present in all European countries. You can always find nearby mechanics trained and qualified to care for your machine. Authorized repairers provide contracts and routine maintenance services, perform emergency repairs and provide you with advice adapted to your needs.



DIMENSIONS

C50R-5

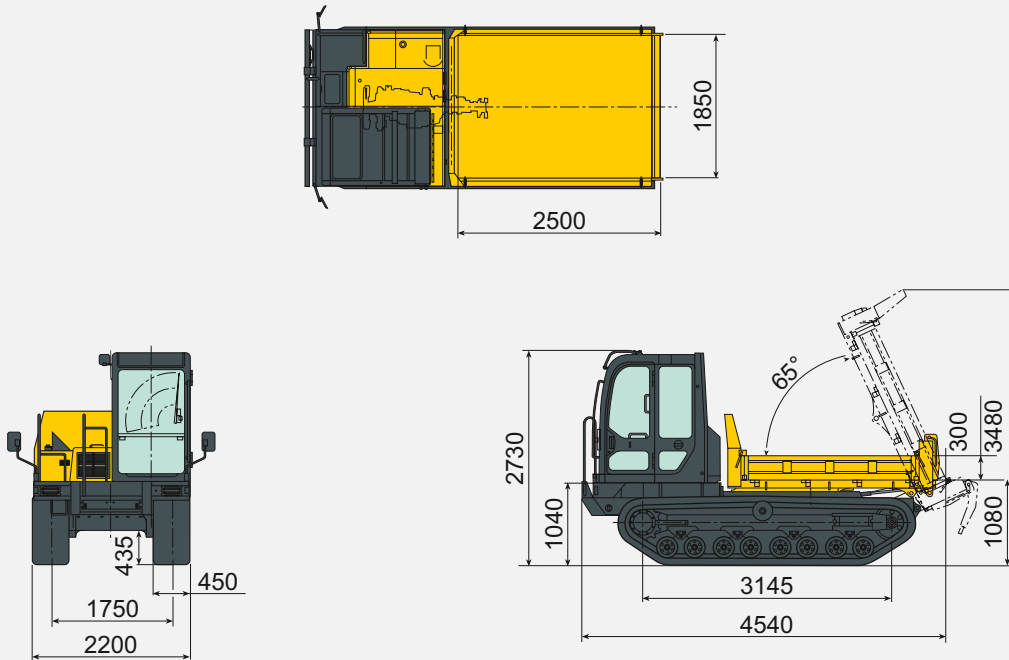

C50R-5 TV

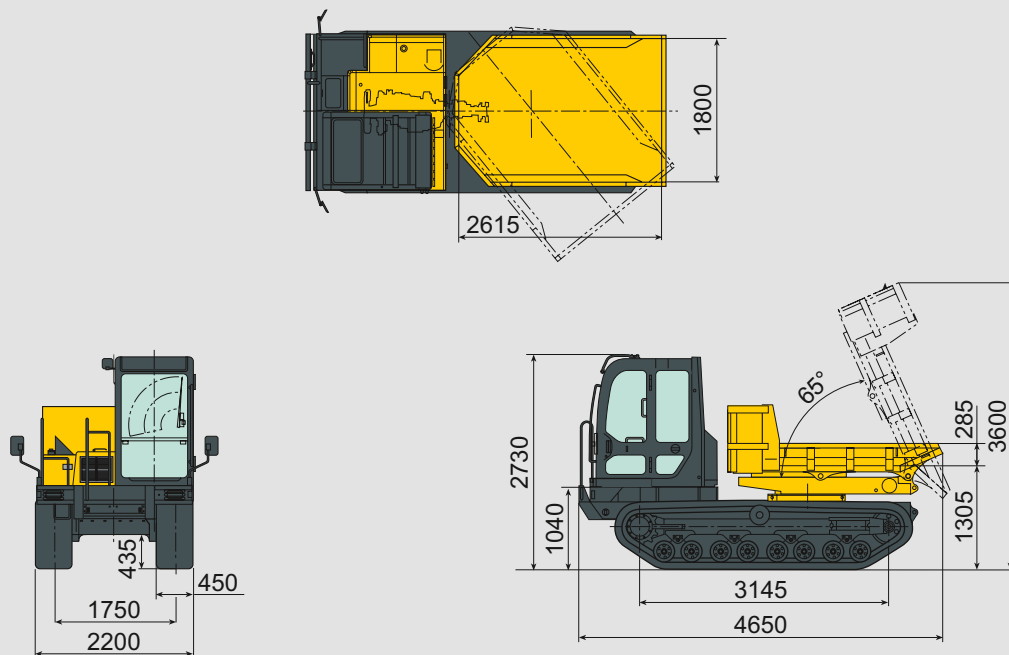



SPECIFICATIONS

WEIGHT +/- 2% (CE STANDARDS)

	C50R-5	C50R-5 TV
Operating weight	5791 kg	6117 kg
Transport weight	5866 kg	6042 kg
Payload	3800 kg	3500 kg

ENGINE

	C50R-5	C50R-5 TV
Type	Direct injection, water cooled, diesel 4TNV94CHT-NTBC	Direct injection, water cooled, diesel 4TNV94CHT-NTBC
Net power	83,2 kW (at 2500 rpm)	83,2 kW (at 2500 rpm)
Displacement	3053 liter	3053 liter
Maximum torque	378-410 N.m	378-410 N.m

PERFORMANCE

	C50R-5	C50R-5 TV
Dumping angle	65 °	65°
Vessel dimensions (L x w x h)	2500*1844*294 mm	2616*1794*285 mm
Dumping mechanism	1 side (rear)	3 sides
Dump vessel capacity (struck/heaped)	1,4 / 2,3 m ³	1,2 / 2,1 m ³
Dump clearance	658 mm	891 mm
Max. travelling speed (foward/reverse)	9,2 km/h	9,2 km/h

UNDERCARRIAGE

	C50R-5	C50R-5 TV
Track width	450 mm	450 mm
Min. ground clearance	433,5 mm	433,5 mm
Ground pressure (unloaded / loaded)	19,8 / 33 kPa	20,9 / 33,1 kPa

MISCELLANEOUS

	C50R-5	C50R-5 TV
Hydraulic transmissions with hydraulic pilot	-	-
Hydraulic tank	44 liter	44 liter
Fuel tank	147,8 liter	147,8 liter
Noise Level Lwa	103 dBA	103 dBA



YANMAR



Non contractual pictures – Printed in France – The manufacturer reserves the right to modify the information in this catalogue without notice. For further information, please contact your authorized Yanmar Construction Equipment dealer.

Yanmar Construction Equipment Europe

25 rue de la Tambourine
52100 Saint-Dizier Cedex
ycee-contact@yanmar.com

www.yanmarconstruction.eu